



**WORKSHOP MANUAL  
TRACTOR**

**B6200HST • B7200HST**

**FOR U.S.A.**

**Кубота**

## TO THE READER

This is the first part of our new Workshop Manual. This part, titled "Mechanism", will be supplemented by a second part titled "Disassembly and Servicing" which we hope will reach you in July, '84. We suggest that you file both parts together with the "B6200-B7200 HST Workshop Manual" which we sent you earlier.

This Workshop Manual consists of Hydrostatic Transmission and only a part of Hydraulic and Electrical system.

Please refer the Workshop Manual of B5200-B6200-B7200 of mechanical transmission type, concerning the other sections.

May, '84

© KUBOTA Corporation 1991

# SPECIFICATIONS

Model		B6200HST 2WD			B6200HST 4WD		
Maximum P.T.O. power		9.3 kW (12.5 HP)*					
Engine gross H.P.		11.2 kW (15 HP)*					
Engine	Model	D850-LA-H					
	Type	Vertical, water-cooled, 4-cycle diesel					
	Number of cylinders	3					
	Bore and stroke	72 mm x 70 mm (2.83 in. x 2.76 in.)					
	Total displacement	855 cm <sup>3</sup> (52.2 cu. in.)					
	Rated revolution	41.7 r/s (2500 rpm)					
	Maximum torque (Net)	49.1 N·m, 5.01 kgf·m, 36.2 ft-lbs/1800 rpm					
	Combustion chamber	Spherical type					
	Fuel injection pump	Bosch K type mini pump (NP-PFR3KD50/2NP4)					
	Governor	Centrifugal ball mechanical governor					
	Injection nozzle	Throttle type (ND-DN12SD12)					
	Injection timing	0.35 to 0.38 rad. (20 to 22 deg.) before T.D.C.					
	Injection order	1-2-3					
	Injection pressure	13.7 to 14.7 MPa (140 to 150 kgf/cm <sup>2</sup> , 1991 to 2131 psi)					
	Compression ratio	22					
	Lubricating system	Forced lubricating by rotor-type pump					
	Cooling system	Pressurized radiator, Forced circulation with water pump					
	Starting system	Electric starting with cell starter (12V, 0.8kW) glow plug and decompression device					
AC dynamo	12V, 150W						
Battery	12V, 45Ah						
Fuel	Diesel fuel No.1-D [below-10°C (15°F)] Diesel fuel No.2-D [above-10°C (15°F)] (ASTM D975)						
Lubricating oil	MIL-L-2104B or MIL-L-2104C, quality better than CC class (API)						
Weight (Dry)	105.0 kg (231 lbs)						
Capacities	Fuel tank	20 ℓ (5.3 U.S.gals., 4.40 Imp.gals.)					
	Engine crankcase	3.1 ℓ (3.3 U.S.qts., 2.73 Imp.qts.)					
	Engine coolant	2.8 ℓ (3.0 U.S.qts., 2.46 Imp.qts.)					
	Transmission case	13.5 ℓ (3.6 U.S.gals., 2.97 Imp.gals.)					
	Steering gear case	0.2 ℓ (0.2 U.S.qts., 0.18 Imp.qts.)					
	Front axle case	0.5 ℓ (0.5 U.S.qts., 0.44 Imp.qts.)					
	Front axle gear case	0.15 ℓ (0.16 U.S.qts., 0.13 Imp.qts.)					
Tires	Front	4.50-10	5.00-10	18x9.50-8	5-12	6-12 B	20.5x8.00-10
	Rear	7-16	8-16	29x12.00-15	7-16	8-16	29x12.00-15
Dimensions	Overall length mm (in.)	2590(102.0)	2590(102.0)	2590(102.0)	2590(102.0)	2590(102.0)	2590(102.0)
	Overall width mm (in.)	910(35.8)	990(39.0)	1140(44.9)	940(37.0)	980(38.6)	1140(44.9)
		960(37.8)	1110(43.7)		960(37.8)	1110(43.7)	
		1080(42.5)			1080(42.5)		
	Overall height with muffler mm (in.)	1795(70.7)	1815(71.5)	1785(70.3)	1810(71.3)	1825(71.9)	1800(70.9)
	Wheel base mm (in.)	1470(57.9)	1470(57.9)	1470(57.9)	1470(57.9)	1470(57.9)	1470(57.9)
	Min. ground clearance mm (in.)	230(9.1)	255(10.0)	240(9.4)	230(9.1)	240(9.4)	210(8.3)
	Treads	Front mm (in.)	710(28.0)	710(28.0)	850(33.5)	785(30.9)	795(31.3)
Rear mm (in.)		740(29.1)	790(31.1)	840(33.1)	740(29.1)	790(31.1)	840(33.1)
		790(31.1)	910(35.8)		790(31.1)	910(35.8)	
Weight kg (lbs)	525(1158)	535(1180)	545(1202)	580(1279)	595(1312)	600(1323)	
P.T.O. shaft	Transmission case rear (Rear P.T.O.), transmission case bottom (Mid P.T.O.) and engine front (Front P.T.O.)						
Rear P.T.O.	SAE 1-3/8 (with over running clutch), 2 speeds (540 and 858 rpm at 2517 engine rpm)						
Mid P.T.O.	USA No.5 Involute spline, 2 speeds (1546 and 2456 rpm at 2517 engine rpm)						
Clutch	Dry single plate						
Steering	Ball screw type						
Transmission	Main-hydrostatic transmission; High-Low gear shift (2 forward, 2 reverse)						
Brake	Internal expanding type, right and left independent with interlocking device						
Min. turning radius m (feet)	2.1 (6.9)			2.3 (7.5)			

■ NOTE: \* Manufacture's estimate.

# SPECIFICATIONS (Continued)

B7200HST 2WD				B7200HST 4WD			
10.5 kW (14 HP)*							
12.7 kW (17 HP)*							
D950-LA-H							
Vertical, water-cooled, 4-cycle diesel							
3							
75 mm x 70 mm (2.95 in. x 2.76 in.)							
927 cm <sup>3</sup> (56.6 cu. in.)							
41.7 r/s (2500 rpm)							
54.0 N·m, 5.51 kgf·m, 39.8 ft-lbs/1600 rpm							
Spherical type							
Bosch K type mini pump (NP-PFR3KD50/2NP4)							
Centrifugal ball mechanical governor							
Throttle type (ND-DN12SD12)							
0.35 to 0.38 rad. (20 to 22 deg.) before T.D.C.							
1-2-3							
13.7 to 14.7 MPa (140 to 150 kgf/cm <sup>2</sup> , 1991 to 2131 psi)							
22							
Forced lubricating by rotor-type pump							
Pressurized radiator, Forced circulation with water pump							
Electric starting with cell starter (12V, 0.8kW), glow plug and decompression device							
12V, 150W							
12V, 45Ah							
Diesel fuel No.1-D [below-10°C (15°F)], Diesel fuel No.2-D [above-10°C (15°F)] (ASTM D975)							
MIL-L-2104B or MIL-L-2104C, quality better than CC class (API)							
105.0 kg (231 lbs)							
20 ℓ (5.3 U.S.gals., 4.40 Imp.gals.)							
3.1 ℓ (3.3 U.S.qts., 2.73 Imp.qts.)							
2.8 ℓ (3.0 U.S.qts., 2.46 Imp.qts.)							
13.5 ℓ (3.6 U.S.gals., 2.97 Imp.gals.)							
0.2 ℓ (0.2 U.S.qts., 0.18 Imp.qts.)							
—				0.5 ℓ (0.5 U.S.qts., 0.44 Imp.qts.)			
—				0.15 ℓ (0.16 U.S.qts., 0.13 Imp.qts.)			
5.00-10	5.00-10	18x9.50-8	18x9.50-8	6-12 B	6-12	20.5x8.00-10	20.5x8.00-10
8-16	9.5-16	29x12.00-15	31x13.5-15	8-16	9.5-16	29x12.00-15	31x13.5-15
2590(102.0)	2590(102.0)	2590(102.0)	2590(102.0)	2590(102.0)	2590(102.0)	2590(102.0)	2590(102.0)
990(39.0)	1045(41.1)	1140(44.9)	1240(48.8)	1050(41.3)	1050(41.3)	1140(44.9)	1240(48.8)
1110(43.7)	1095(43.1)			1110(43.7)	1095(43.1)		
	1145(45.1)				1145(45.1)		
	1265(49.8)				1265(49.8)		
1815(71.5)	1815(71.5)	1785(70.3)	1785(70.3)	1830(72.0)	1840(72.4)	1805(71.1)	1805(71.1)
1470(57.9)	1470(57.9)	1470(57.9)	1470(57.9)	1470(57.9)	1470(57.9)	1470(57.9)	1470(57.9)
255(10.0)	285(11.2)	240(9.4)	250(9.8)	240(9.4)	255(10.0)	215(8.5)	215(8.5)
710(28.0)	710(28.0)	850(33.5)	850(33.5)	860(33.9)	860(33.9)	895(35.2)	895(35.2)
790(31.1)	795(31.3)	840(33.1)	895(35.2)	790(31.1)	795(31.3)	840(33.1)	895(35.2)
910(35.8)	845(33.3)			910(35.8)	845(33.3)		
	895(35.2)				895(35.2)		
	1015(40.0)				1015(40.0)		
535(1180)	550(1213)	545(1202)	550(1213)	605(1334)	615(1356)	610(1345)	615(1356)
Transmission case rear (Rear P.T.O.), transmission case bottom (Mid P.T.O.) and engine front (Front P.T.O.)							
SAE 1-3/8 (with over running clutch), 2 speeds (540 and 858 rpm at 2517 engine rpm)							
USA No.5 Involute spline, 2 speeds (1546 and 2456 rpm at 2517 engine rpm)							
Dry single plate							
Ball screw type							
Main-hydrostatic transmission; High-Low gear shift (2 forward, 2 reverse)							
Internal expanding type, right and left independent with interlocking device							
2.1 (6.9)				2.2 (7.2)			

■ NOTE: \* Manufacture's estimate.

# M MECHANISM

## CONTENTS

<b>F</b> FEATURES	M.F
<b>2</b> TRANSMISSION	M.2
[1] HYDROSTATIC TRANSMISSION	M.2-1
(1) Structure	M.2-2
(2) Pump and Motor	M.2-5
(3) Oil Flow and Valves	M.2-6
(4) Operation	M.2-9
(5) Control Linkage	M.2-15
[2] MECHANICAL TRANSMISSION	M.2-16
(1) High-Low Gear Shift Section	M.2-16
(2) Front Wheel Drive Section [4WD Type Only]	M.2-18
(3) PTO Shift Section	M.2-19
(4) One-Way Clutch Cam Section	M.2-20
<b>7</b> HYDRAULIC SYSTEM	M.7
[1] OIL COOLER	M.7-2
<b>8</b> ELECTRICAL SYSTEM	M.8
[1] WIRING DIAGRAM AND ELECTRICAL CIRCUIT	M.8-1
(1) Wiring Diagram	M.8-1
(2) Electrical Circuit	M.8-2

# F FEATURES

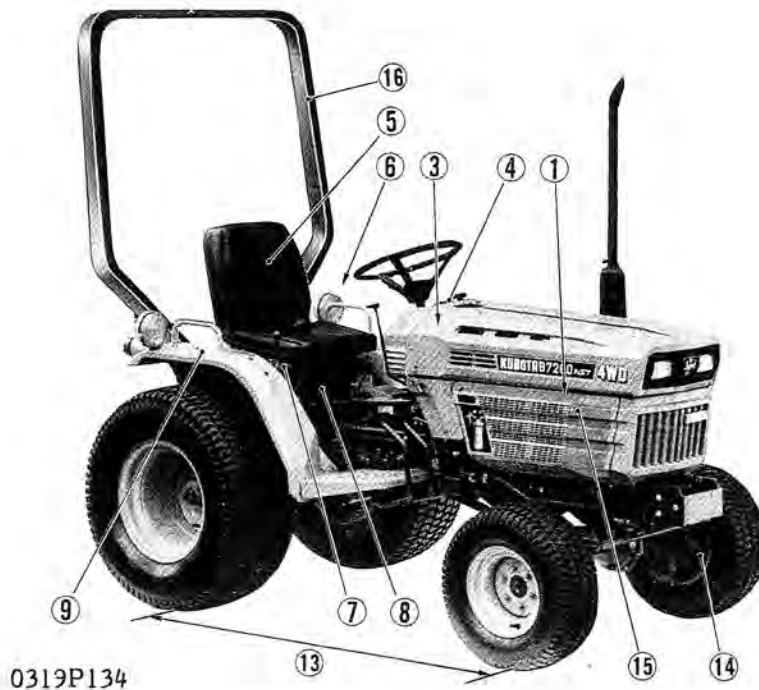

0319P134

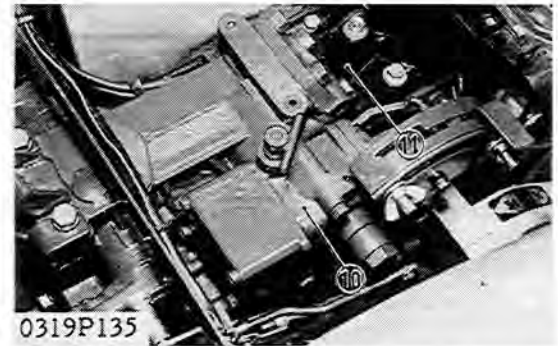

0319P135

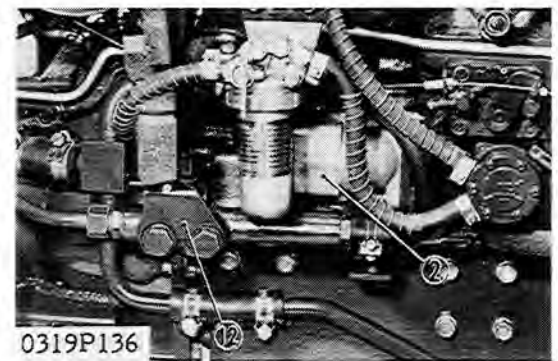

0319P136

- [1] Engine cylinder displacement is increased to augment its output.
- [2] The hydraulic pump delivery is increased 25% (compared with B6100-B7100 HST) to take care of front loader and other implements.
- [3] The fuel tank capacity is increased to permit longer hours of continuous operation. The metallic tank is tough and durable.
- [4] The fuel gauge constantly reminds the user of the remaining amount of fuel.
- [5] The seat is newly styled and engineered for greater comfort.
- [6] The operator's area is enlarged to allow the user to operate in a less-tiring posture.
- [7] The spring-suspended seat absorbs shock from the ground to reduce fatigue.
- [8] The seat can be easily shifted back and forth so you can select the seat position that is most comfortable.
- [9] The fender edge is rolled back to prevent injury during tire replacement.
- [10] The position control for the hydraulic unit greatly improves maneuverability. This feature is available for B6200 HST 4WD and B7200 HST 4WD.
- [11] Rear hydraulic outlet is provided under the operator's seat. With the outlet valve (optional), implement operations are greatly assisted.
- [12] The hydraulic block type outlet for the front loader is provided at the right side of the tractor.
- [13] The wheelbase is lengthened to receive the 60 inch mid-mounting mower for greater mowing capability.
- [14] A bevel gear type front axle is adapted. Engine output is transmitted to the front wheels for powerful, smooth driving action. This feature is available for B7200 HST 4WD only.
- [15] The side and front of the tractor, near the engine, are each fitted with a safety cover. This safety feature prevents burns and other accidents caused by touching the rotating or hot parts of the engine.
- [16] Optional ROPS is recommended for added safety. It can be attached any time.

# 2 TRANSMISSION

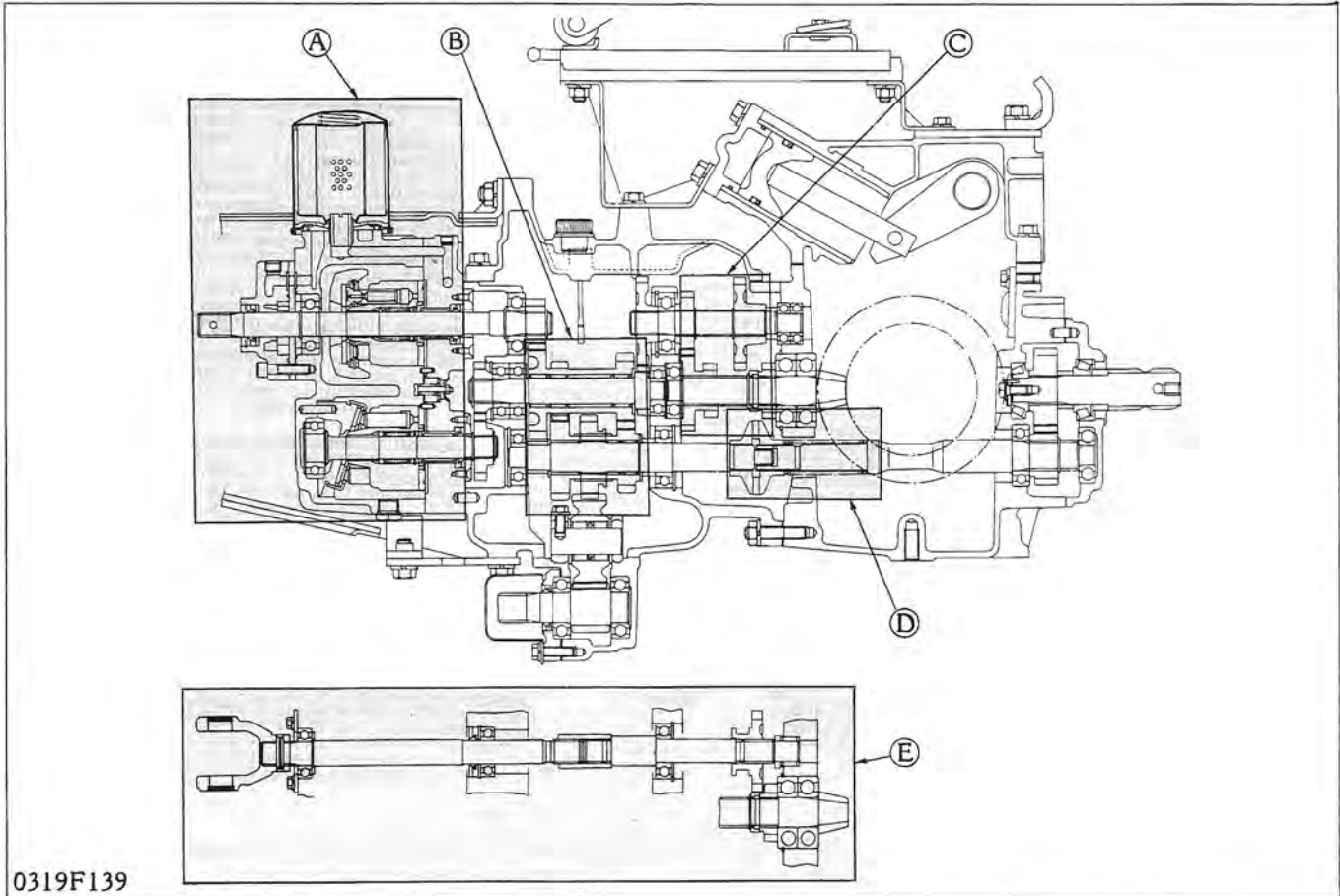

0319F139

- (A) Hydrostatic Transmission
- (B) PTO Shift Section (1 · 2 · N)
- (C) High-Low Gear Shift Section

- (D) One-Way Clutch Cam Section
- (E) Front Wheel Drive Section (Engaged - Disengaged)

The transmission consists of HST (Hydrostatic Transmission) and a series of gears shown previously. It offers the most suitable speeds for traveling and operation by combination of them. And power is transmitted to the front or rear axles and the PTO shafts, which are classified respectively as the traveling system and PTO system.

The traveling system consists of the HST (A), high-low gear shift section (C) and front wheel drive section (E). The traveling speeds are selected by the operation of the speed control pedal and the high-low gear shift lever.

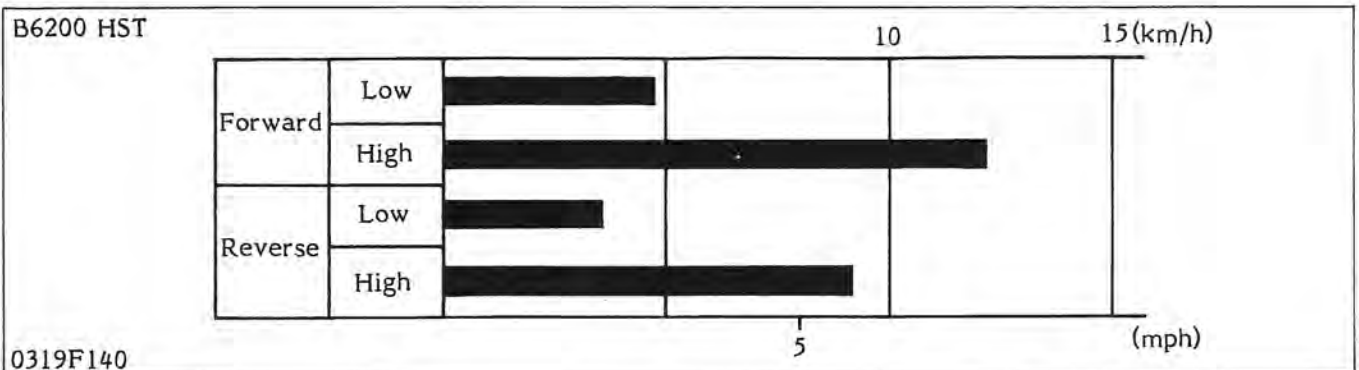

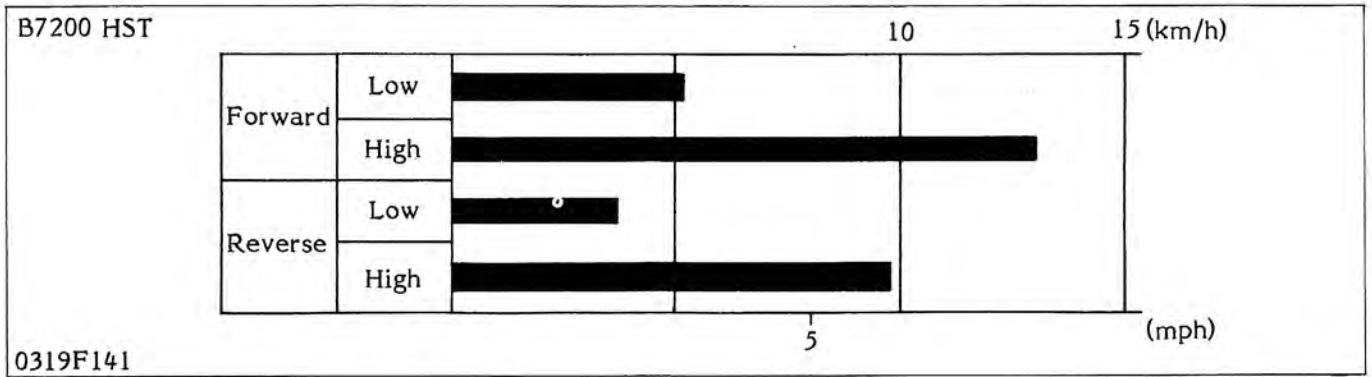

[1] Hydrostatic Transmission

(1) Structure

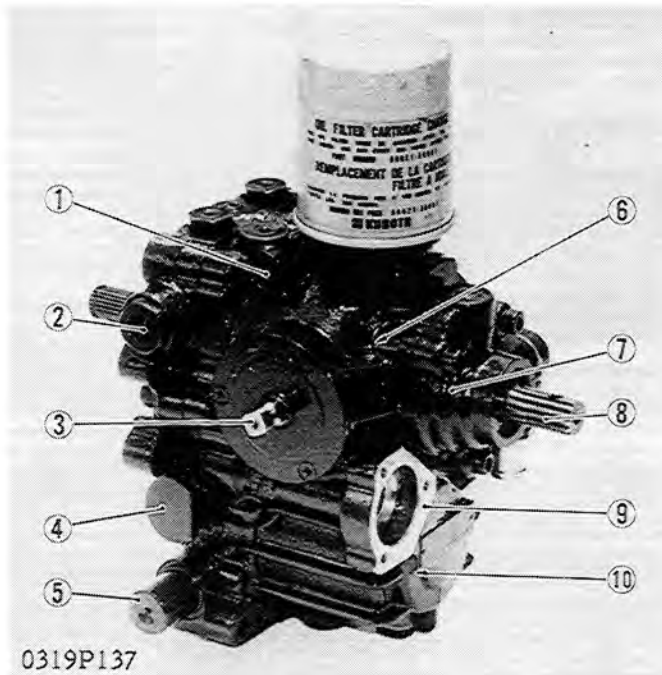

- (1) Charge Relief Valve
- (2) Neutral Valve
- (3) Trunnion Shaft
- (4) Port Block
- (5) High Pressure Relief Valve
- (6) Variable Displacement Piston Pump

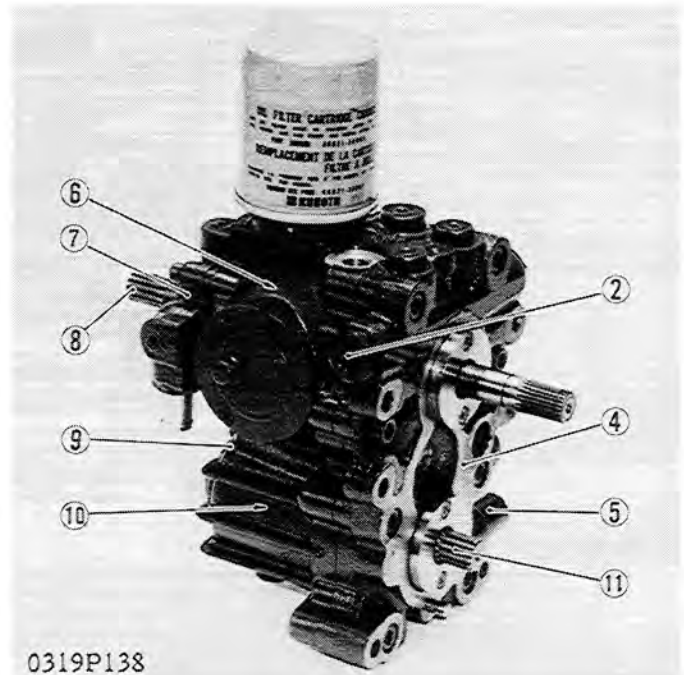

- (7) Charge Pump
- (8) Input Shaft
- (9) Case
- (10) Fixed Displacement Piston Motor
- (11) Output Shaft

Hydrostatic transmission is composed of variable displacement piston pump, fixed displacement piston motor, charge pump and valve system.



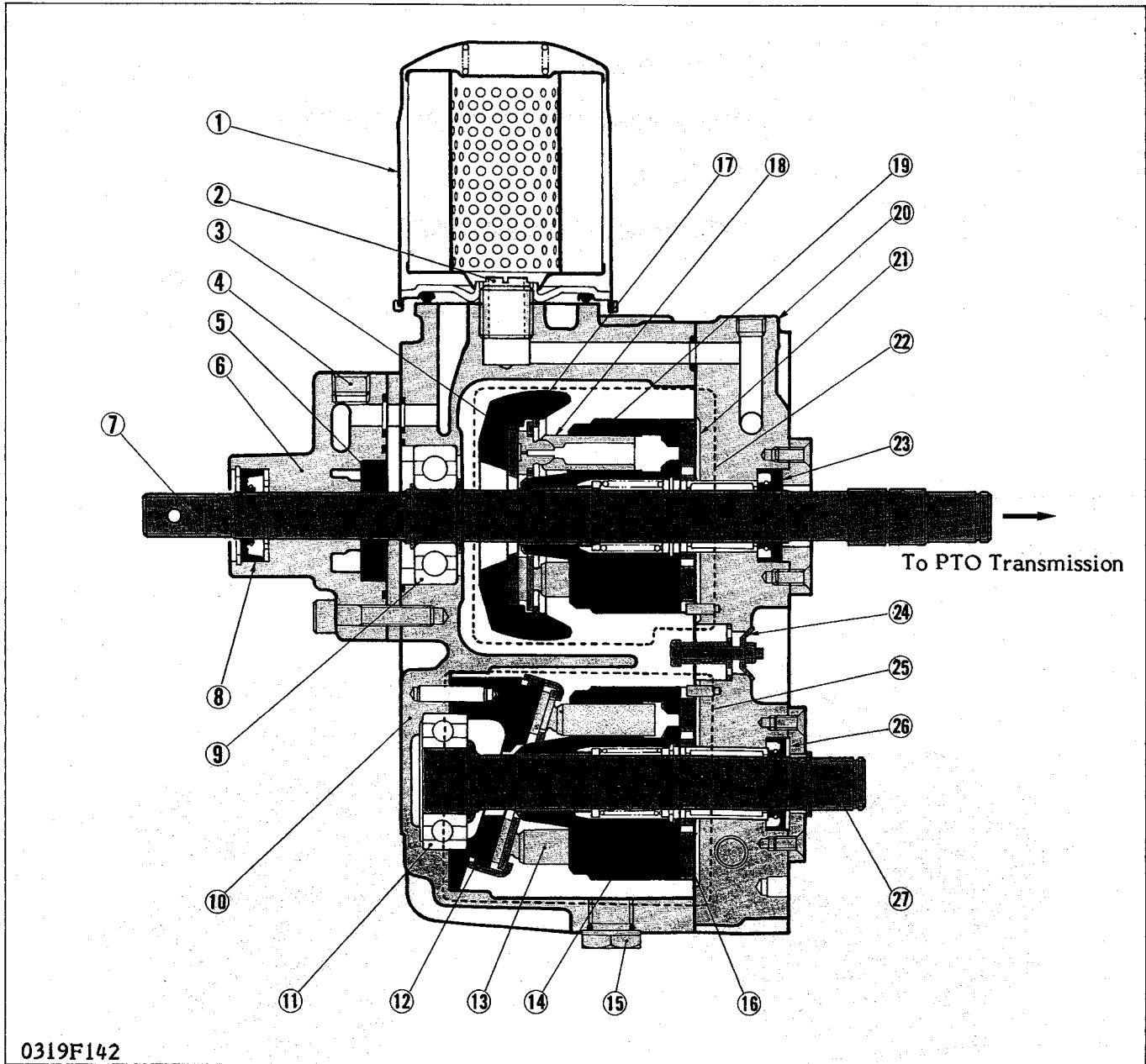

0319F142

- |                             |                          |   |
|-----------------------------|--------------------------|---|
| (1) Oil Filter Cartridge    | (11) Ball Bearing        | (21) Valve Plate                          |
| (2) Joint                   | (12) Fixed Swashplate    | (22) Variable Displacement<br>Piston Pump |
| (3) Thrust Plate            | (13) Piston              | (23) Oil Seal                             |
| (4) P3 Port                 | (14) Cylinder Block      | (24) Case Relief Valve                    |
| (5) Trochoid Rotor Assembly | (15) Drain Plug          | (25) Fixed Displacement<br>Piston Motor   |
| (6) Charge Pump Case        | (16) Valve Plate         | (26) Oil Seal                             |
| (7) Input Shaft             | (17) Variable Swashplate | (27) Output Shaft                         |
| (8) Oil Seal                | (18) Piston              |   |
| (9) Ball Bearing            | (19) Cylinder Block      |   |
| (10) Case                   | (20) Port Block          |   |

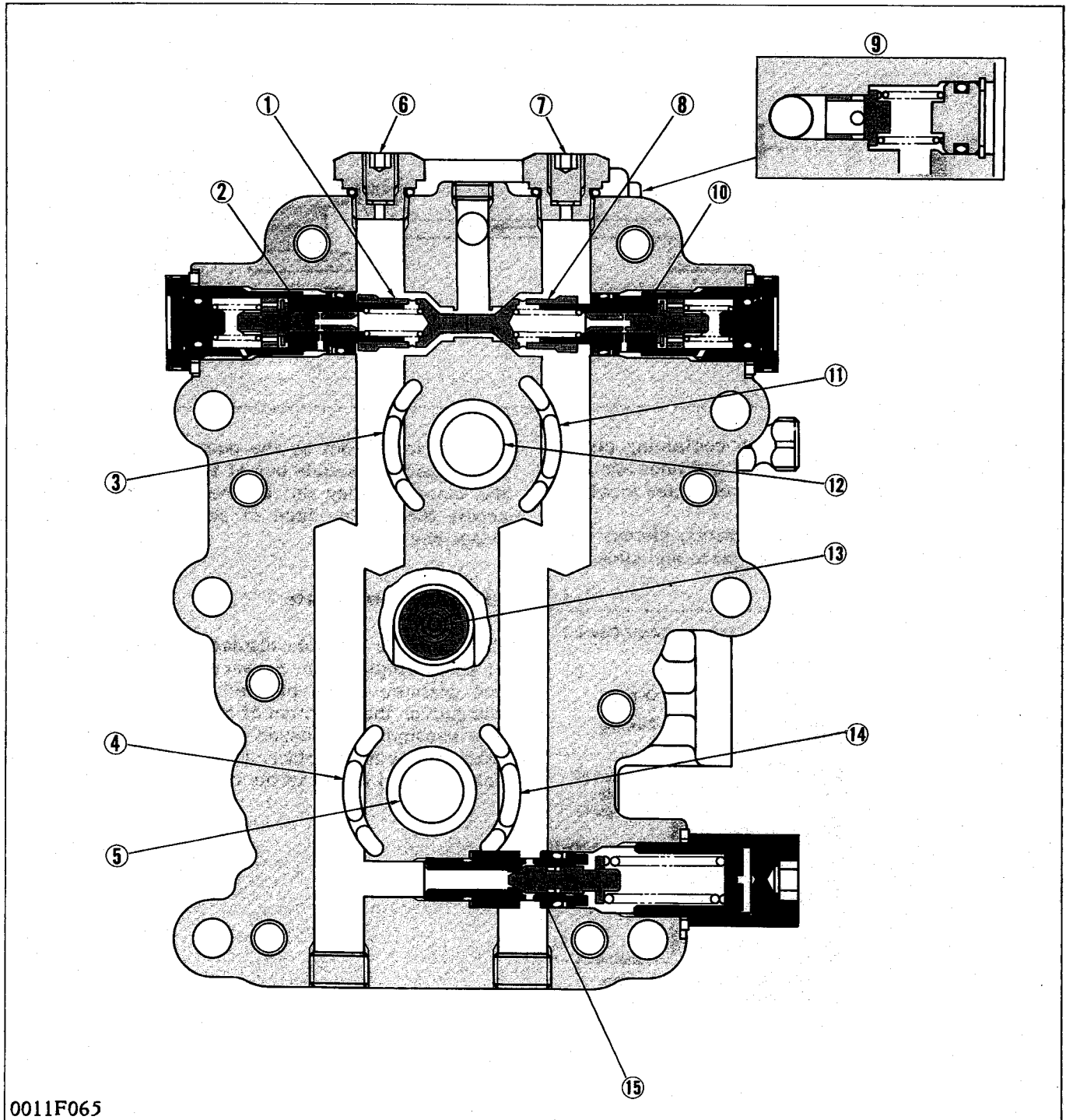

0011F065

- (1) Check Valve
- (2) Neutral Valve (Forward)
- (3) Pump Kidney Port A
- (4) Motor Kidney Port C
- (5) Output Shaft
- (6) P1 Port
- (7) P2 Port
- (8) Check Valve

- (9) Charge Relief Valve
- (10) Neutral Valve (Reverse)
- (11) Pump Kidney Port B
- (12) Input Shaft
- (13) Case Relief Valve
- (14) Motor Kidney Port D
- (15) High Pressure Relief Valve

**(2) Pump and Motor**

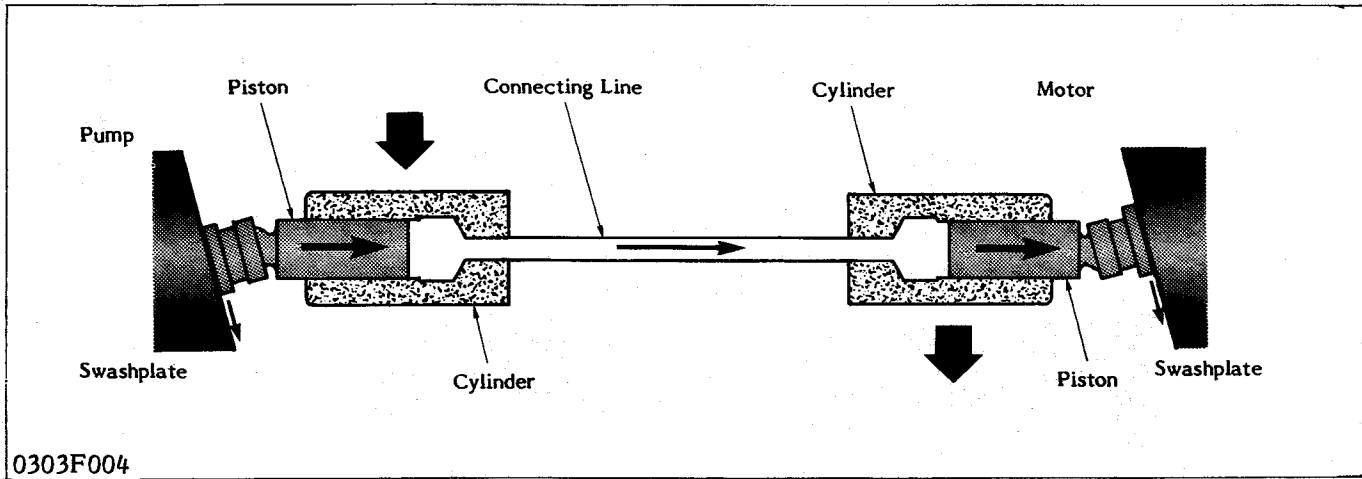

0303F004

Pump and motor cylinder, each containing pistons, are connected by lines. Cylinders and lines are filled with oil. Pistons ride against swashplates located in pump and motor. In the pump, as the cylinder rotates, pistons move across the sloping face of swashplate and slide in or out of their cylinder bores.

The oil, forced out by the pump pistons, causes the motor pistons to slide out of their cylinder bores. In the motor, sliding out of the cylinder and moving across the sloping face of swashplate, the pistons rotate the cylinder.

**(2) Variable Swashplate**

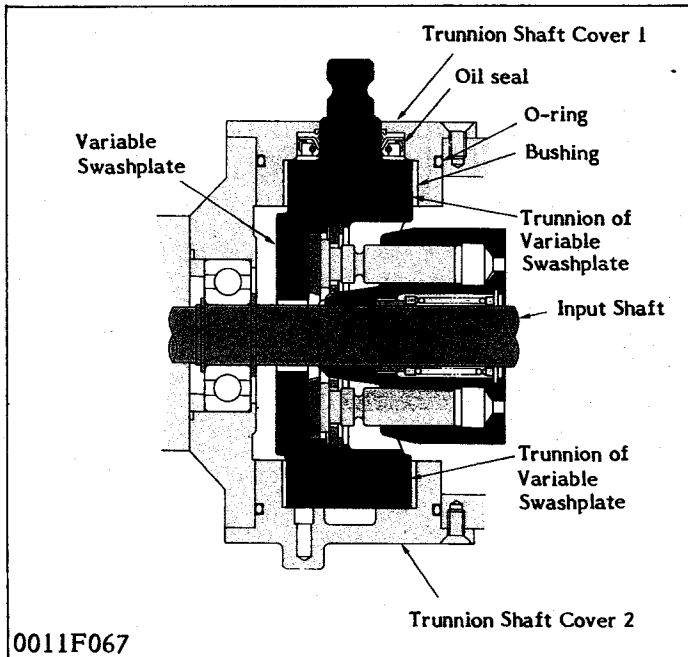

0011F067

This pump is variable displacement one. The angle of its swashplate can be varied so that the volume and pressure of oil pumped by the pistons can be changed or the direction of oil flow can be reversed. The swashplate is moved around the trunnion shaft with the neutral holder, by stepping on the speed control pedal linked to the neutral holder.

**(4) Oil Flow and Valves**

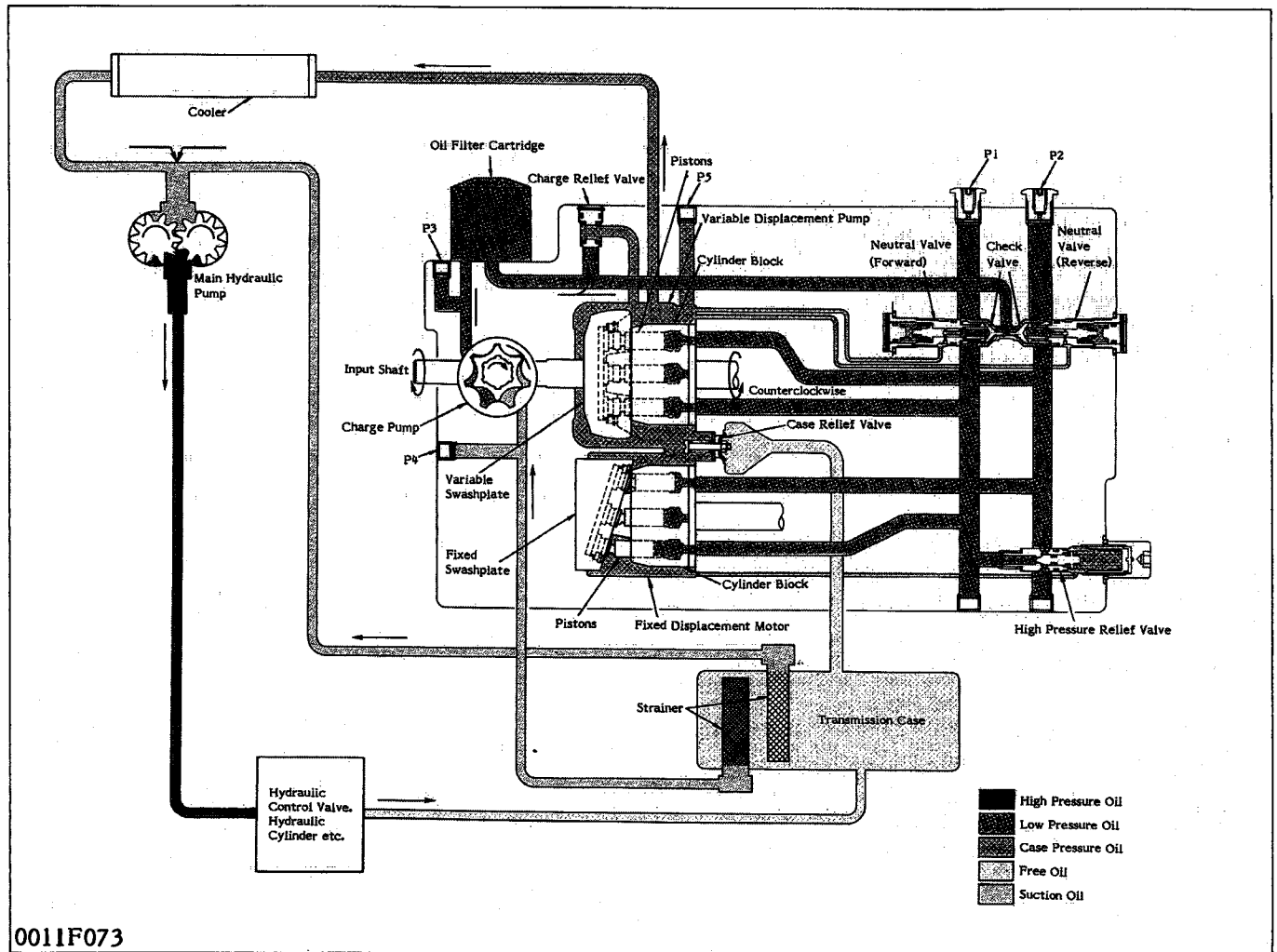

P1: Port for checking high pressure (forward)  
 P2: Port for checking high pressure (reverse)  
 P3: Port for checking case pressure

P4: Port for checking vacuum  
 P5: Port for checking case pressure

The pump and motor are joined in a closed hydraulic loop and most of oil circulates within the main oil circuit. A little oil lubricates and oozes out from the clearance between the moving parts to the case. Then oil in the main oil circuit of the hydrostatic transmission needs to be supplied a want. So all of oil fed from the main hydraulic pump flows to the hydrostatic transmission for charging.

Only return oil from the hydraulic cylinder drops to the transmission case. The charge oil aids smooth operation of piston pump and motor. The rest of the oil passes through the charge relief valve into the case. Then the oil passes to the main hydraulic pump through a cooler.

1. Charge Relief Valve

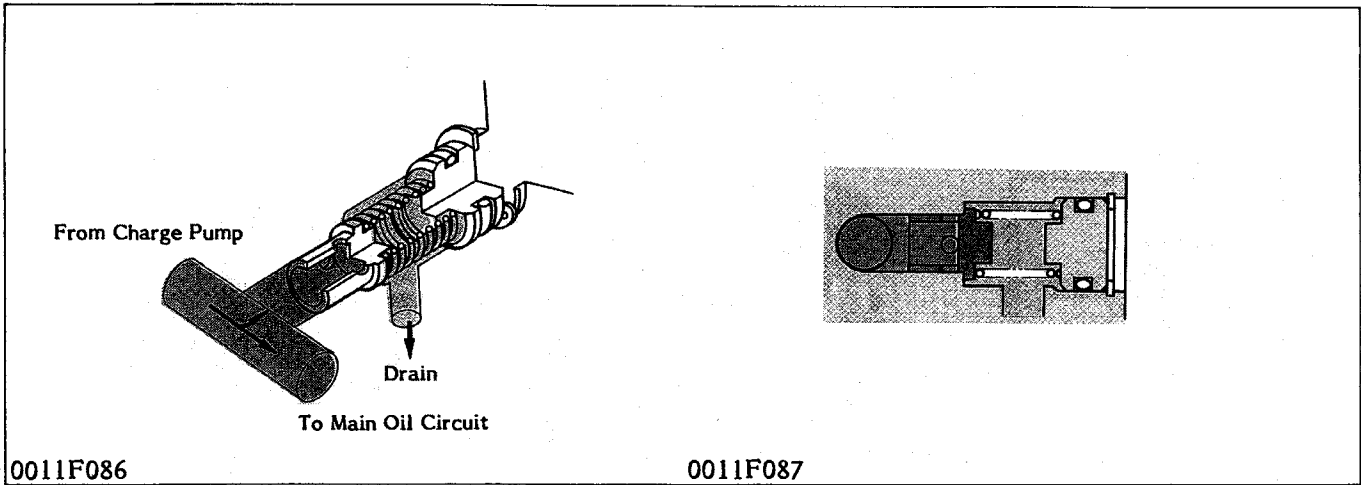

While pumped and filtered oil flows into the main oil circuit through the check valves, excessive oil passes to the case through the charge relief valve.

Oil temperature	Valve operating pressure
25°C (77°F)	440 to 580 kPa (4.5 to 5.9 kgf/cm <sup>2</sup> , 64 to 84 psi) more than case pressure
50°C (122°F)	420 to 560 kPa (4.3 to 5.7 kgf/cm <sup>2</sup> , 61 to 81 psi) more than case pressure

2. Neutral Valve

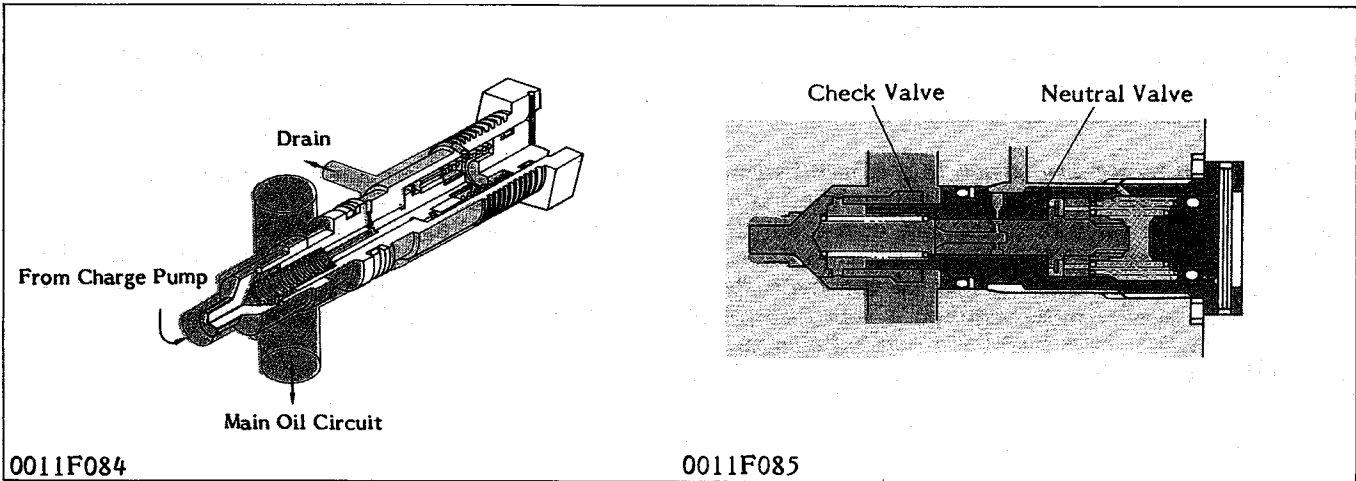

The neutral valves in the main oil circuit lines are open and pass the oil to the case when in neutral, and the oil pressure in their lines becomes low. And when the oil pressure in the high pressure line increases to a specified pressure, the neutral valve closes.

Valve operating pressure
Approx. 3.24 MPa (33 kgf/cm <sup>2</sup> , 469 psi)

**3. High Pressure Relief Valve**

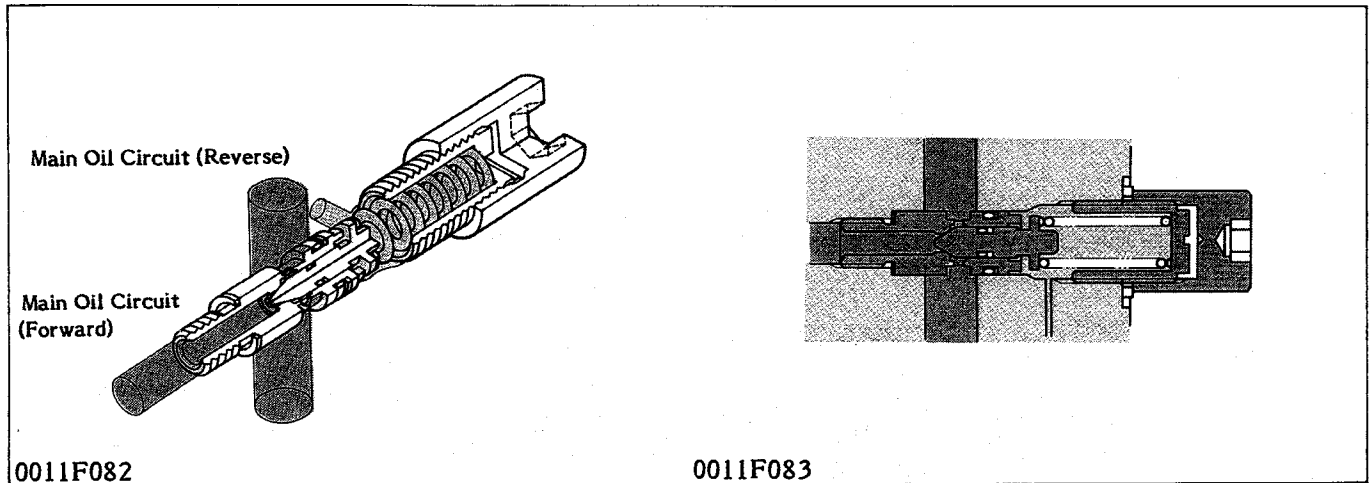

The high pressure relief valve between the two lines in the main oil circuit monitors the oil pressure in each line. When excessively high pressure is built up in one line, it opens and flows the oil into another line.

Oil temperature	Valve operating pressure
25° to 50°C (77° to 122°F)	22.5 to 24.5 MPa (230 to 250 kgf/cm <sup>2</sup> , 3270 to 3560 psi)

**4. Case Relief Valve**

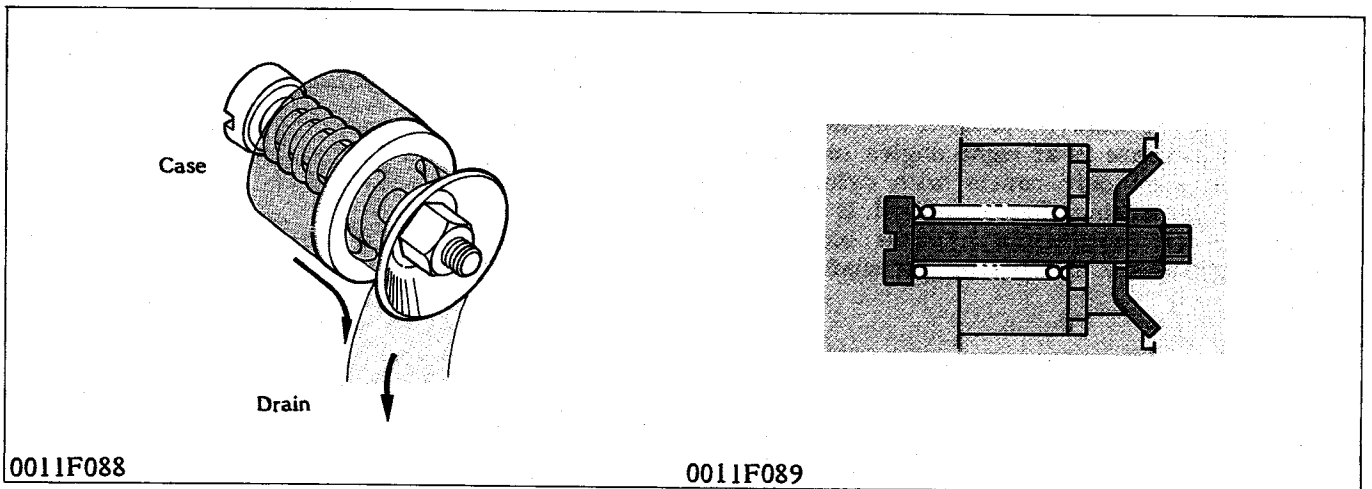

The case relief valve monitors the oil pressure in the hydrostatic transmission case. When the oil pressure rises, it opens and flows the oil directly to the transmission case, so that the oil may not leak against the sealings.

Oil temperature	Valve operating pressure
25° to 50°C (77° to 122°F)	170 to 230 kPa (1.7 to 2.3 kgf/cm <sup>2</sup> , 24 to 32 psi)

## (5) Operation

## ■ Neutral

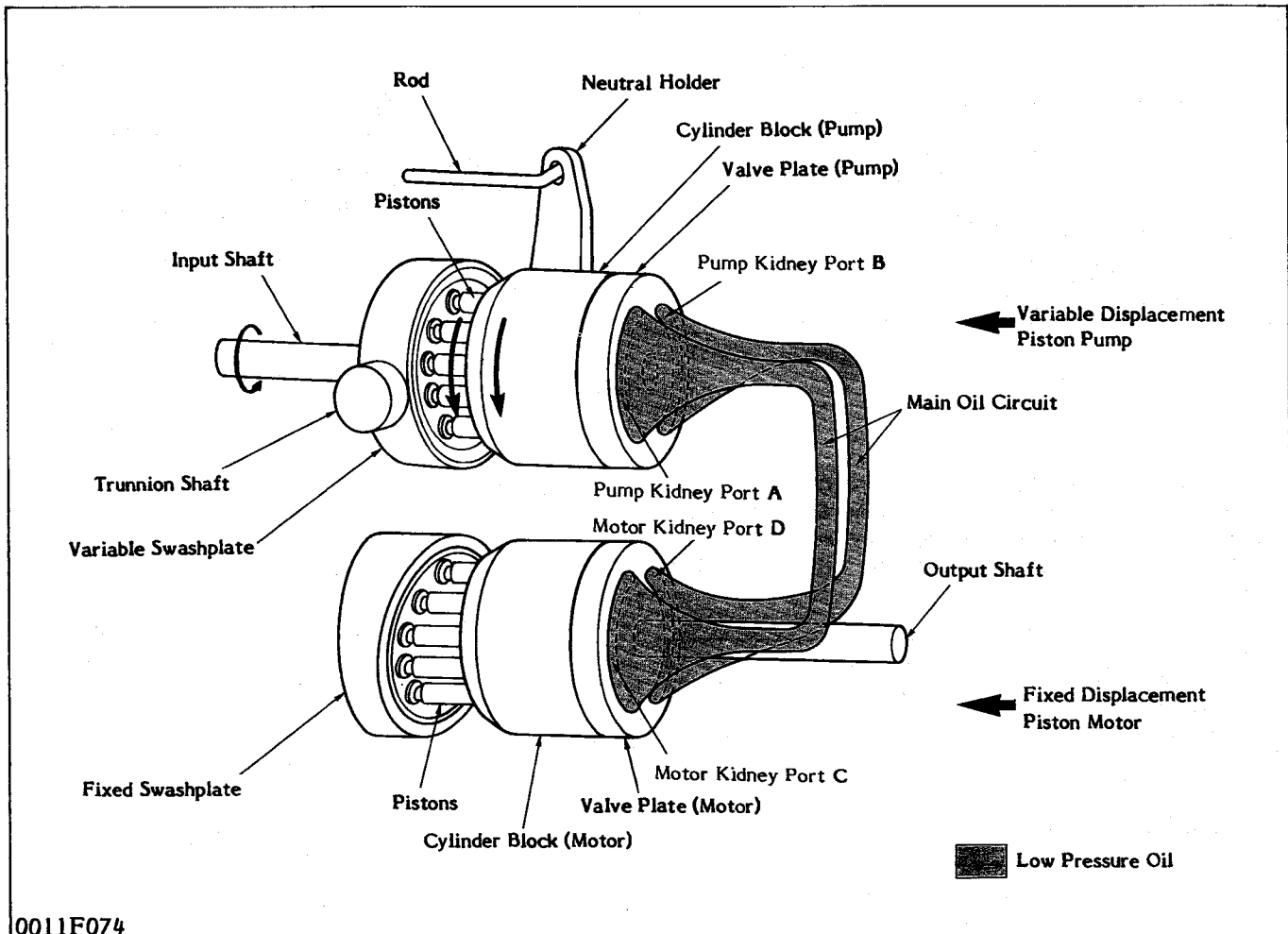

When the speed control pedal is in neutral, the variable swashplate is at right angles to the pump pistons and they only rotate with cylinder block without reciprocating. Since the oil is not being pumped to the motor, the cylinder block in the motor is stationary and the output shaft does not move.

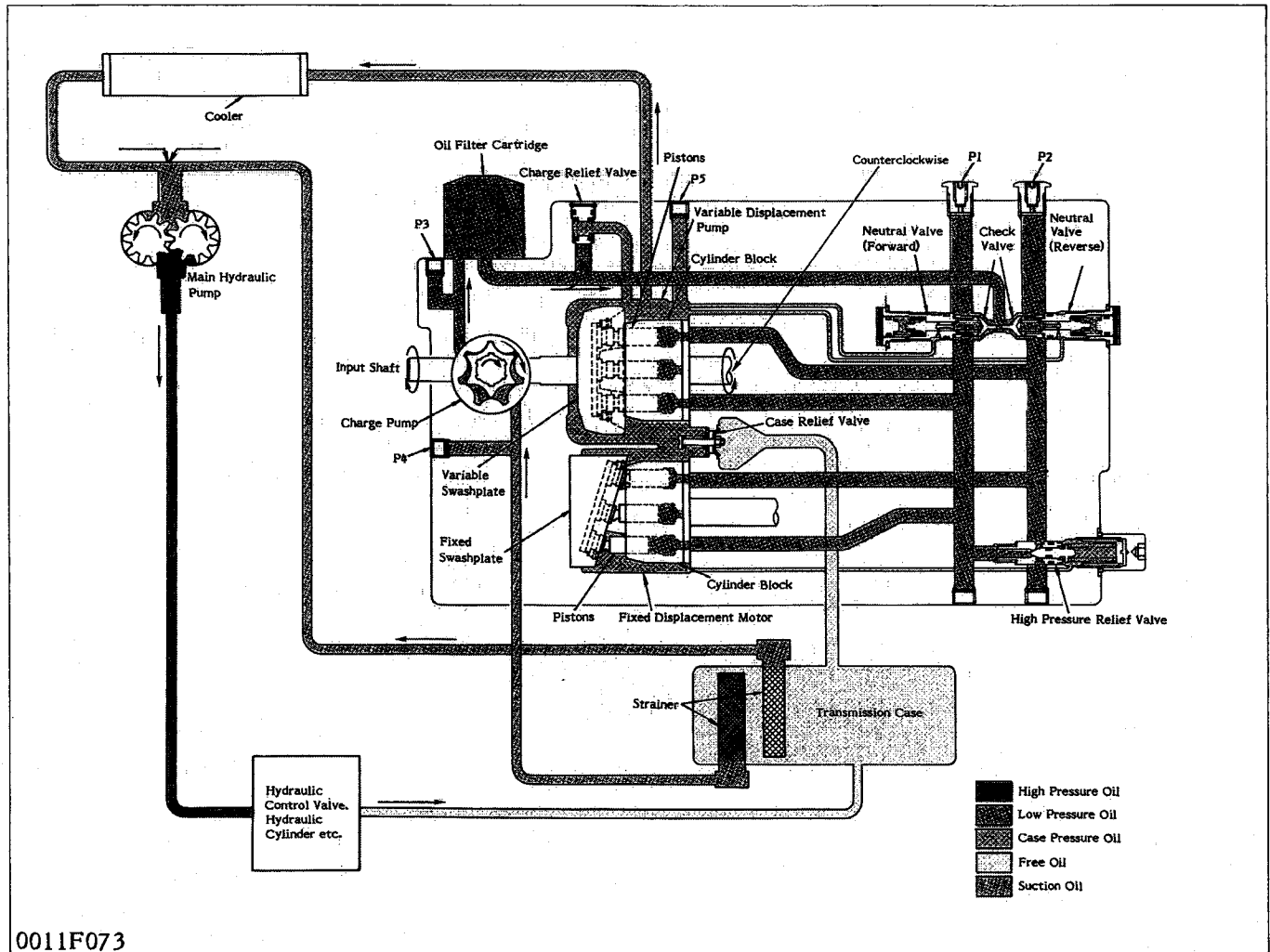



■ Forward

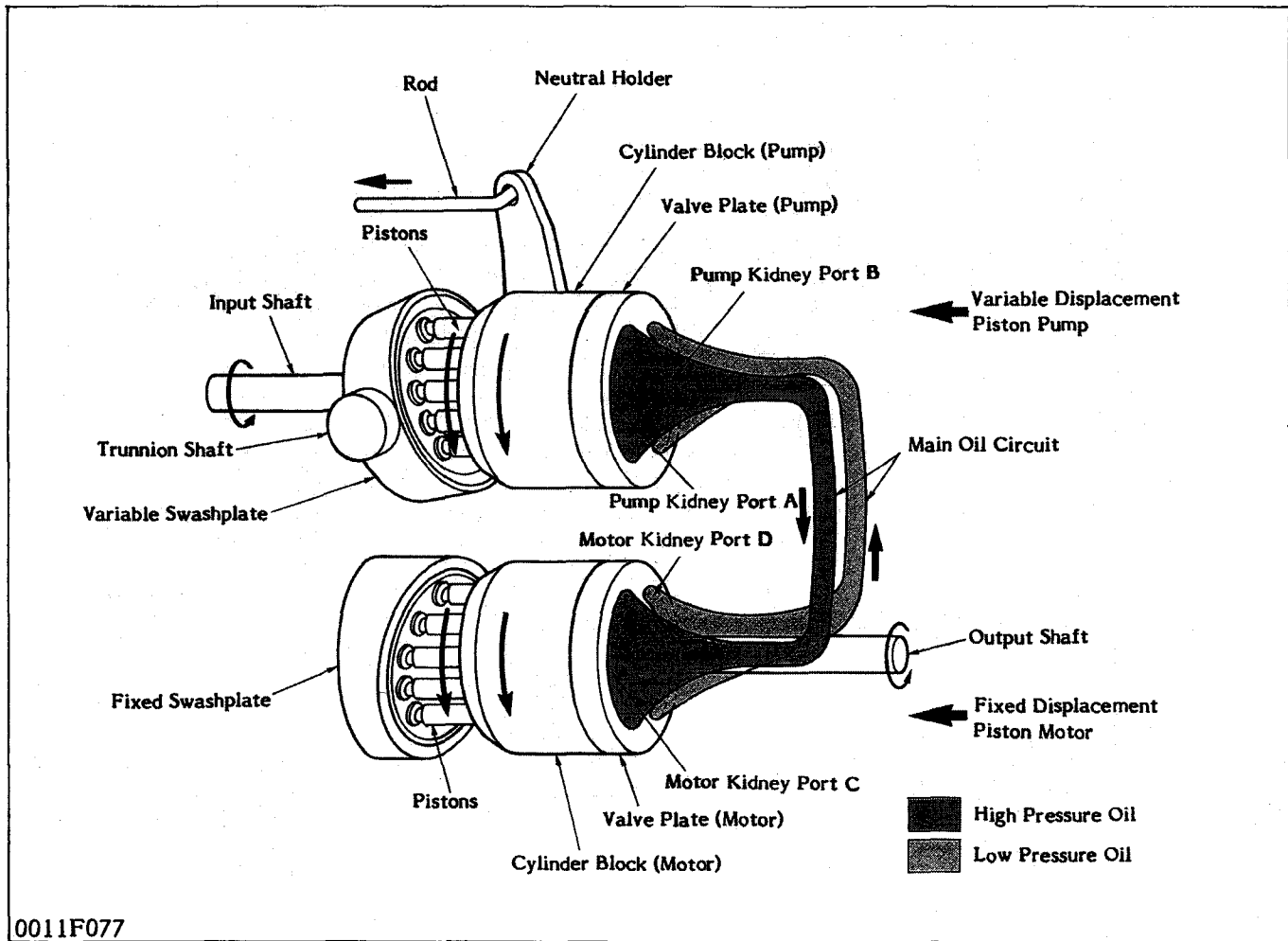

When the speed control pedal is stepped on and in forward, the variable swashplate is tilted as shown in figure above.

As the pump cylinder block rotates with the input shaft, oil is forced out of pump kidney port A at high pressure. As pressure oil enters motor kidney port C, the pistons, which align with port C, are pushed against the swashplate and slide down the inclined surface.

Then the output shaft rotates with the motor cylinder block. This drives the machine forward and the angle of pump swashplate determines the output shaft speed.

As the motor cylinder block continues to rotate, oil is forced out of motor kidney port D at low pressure and returns to the pump.

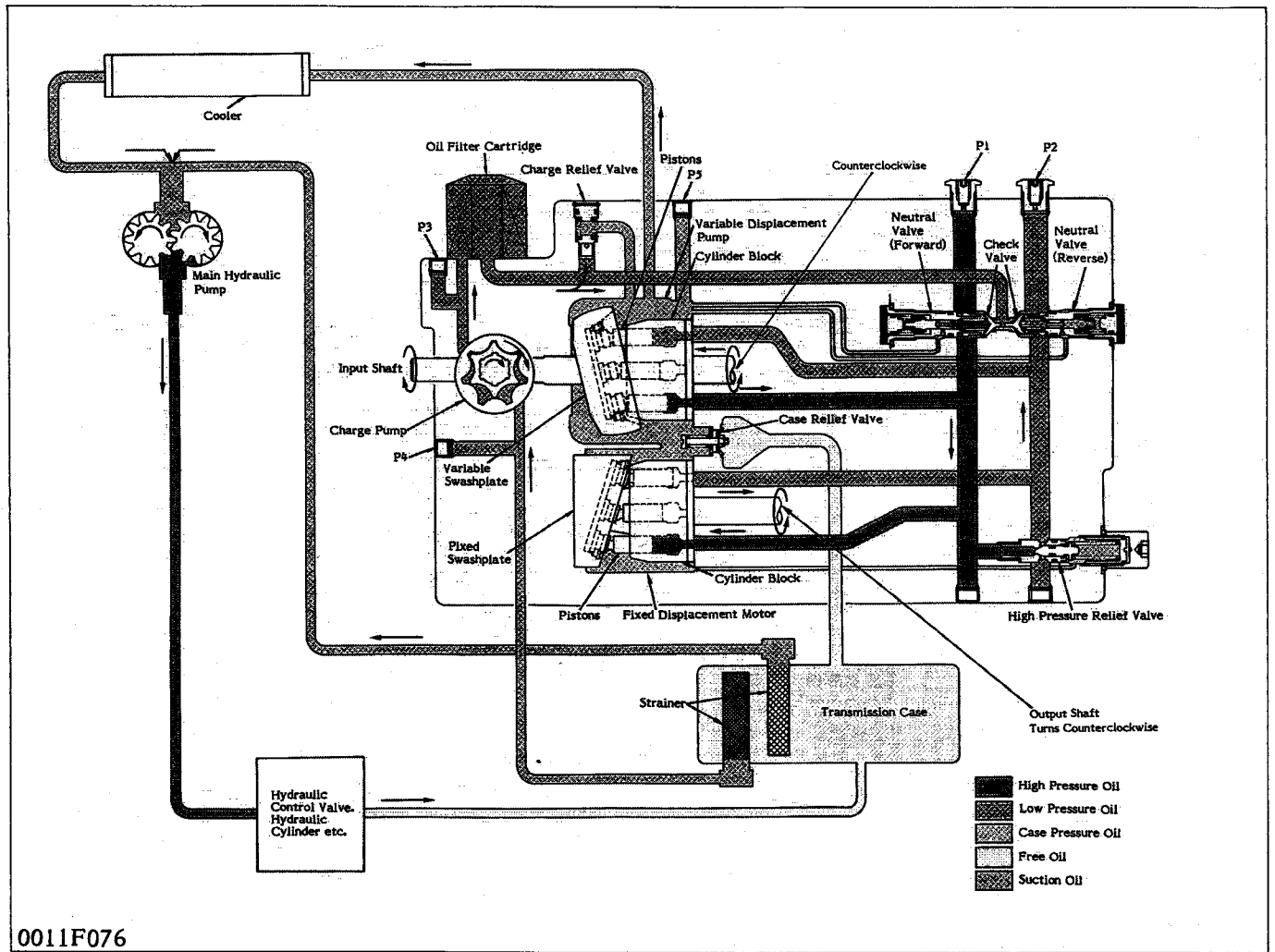

## Reverse

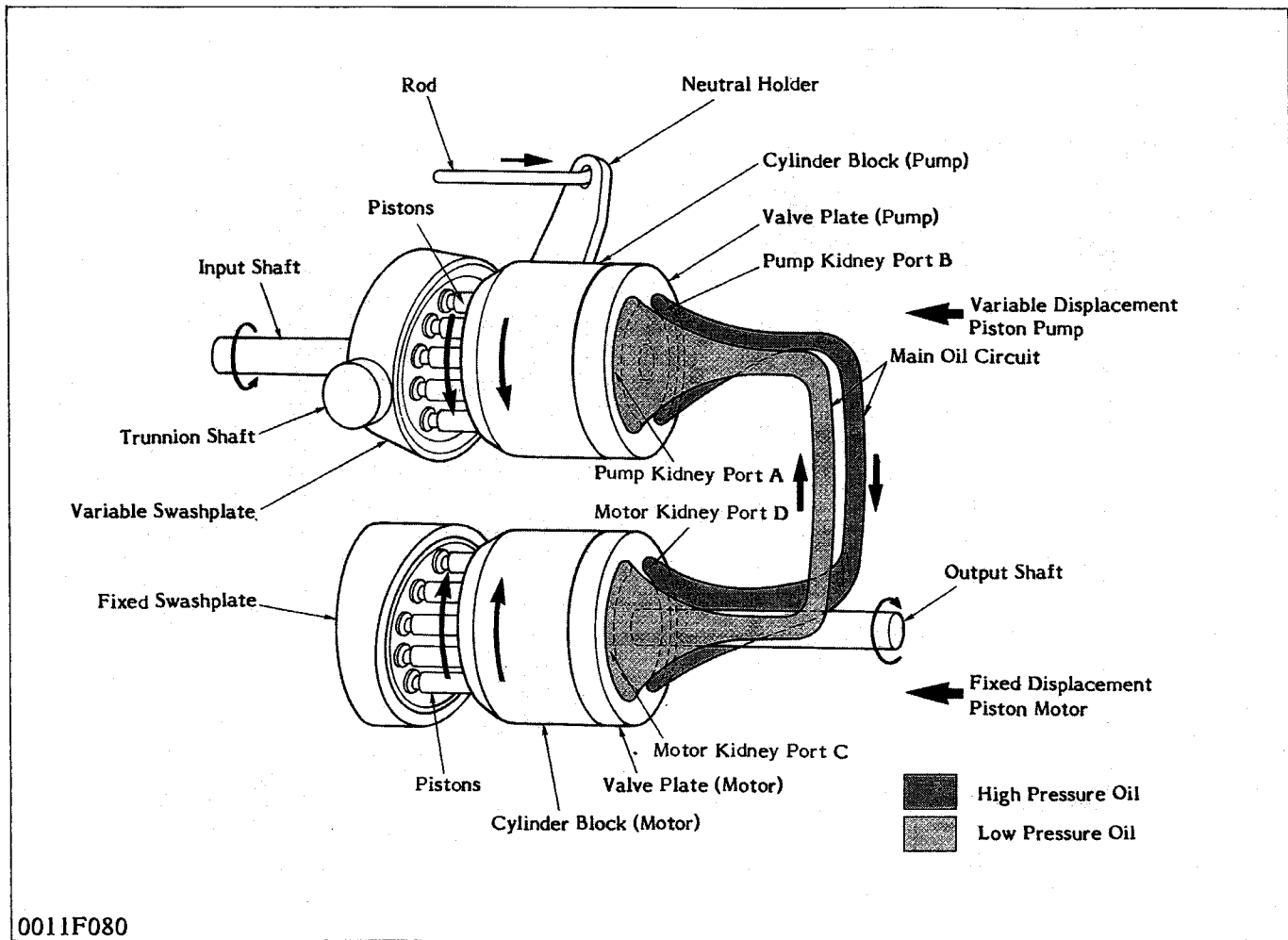

When the speed control pedal is stepped on and in reverse, the variable swashplate is tilted as shown in figure above.

As the pump cylinder block rotates with the input shaft, oil is forced out of pump kidney port B at high pressure. As pressure oil enters motor kidney port D, the pistons, which align with the swashplate and slide down the inclined surface.

Then the output shaft rotates with the motor cylinder block. This drives the machine rearward and the angle of pump swashplate determines the output shaft speed.

As the motor cylinder block continues to rotate, oil is forced out of motor kidney port C at low pressure and returns to the pump.

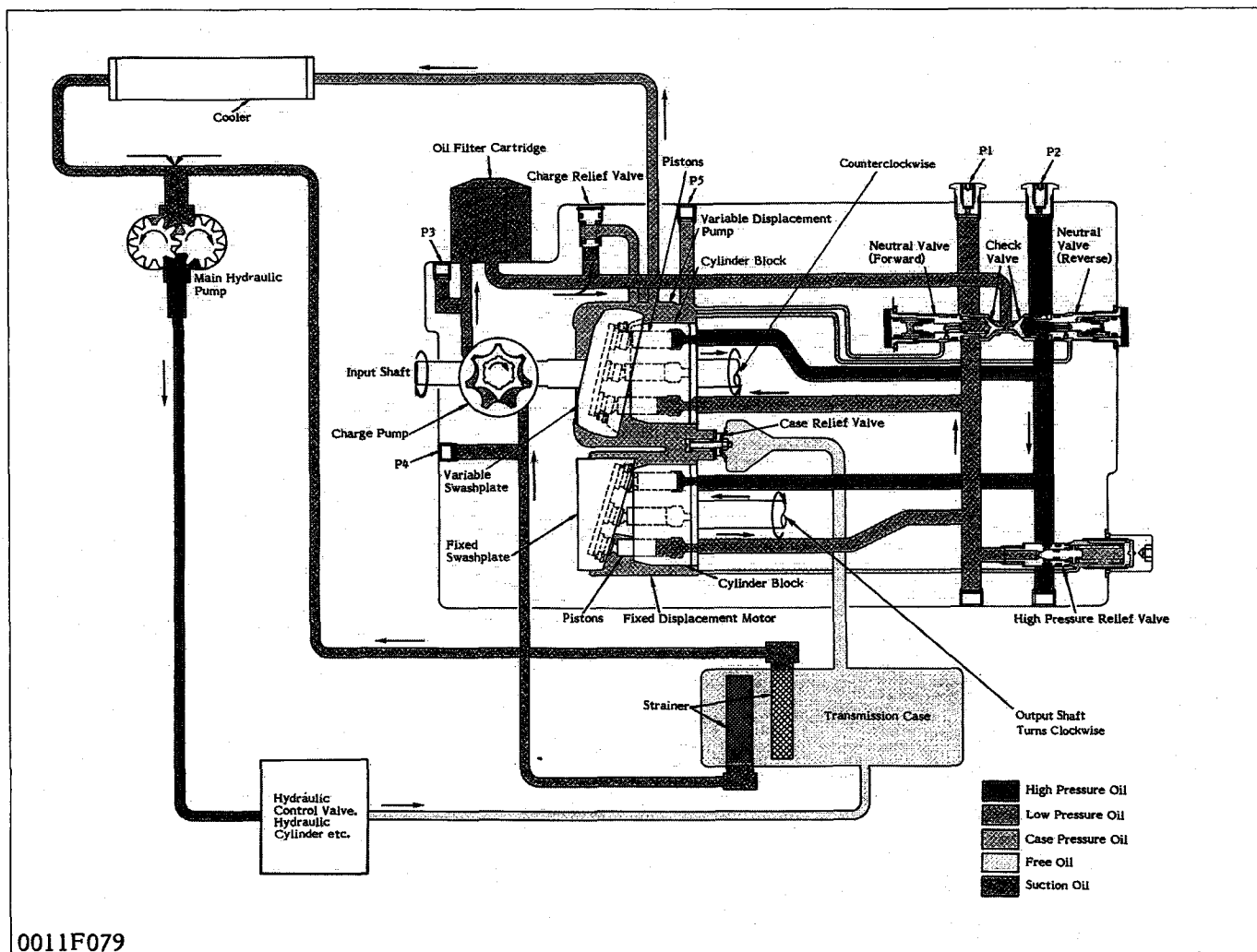

## (6) Control Linkage

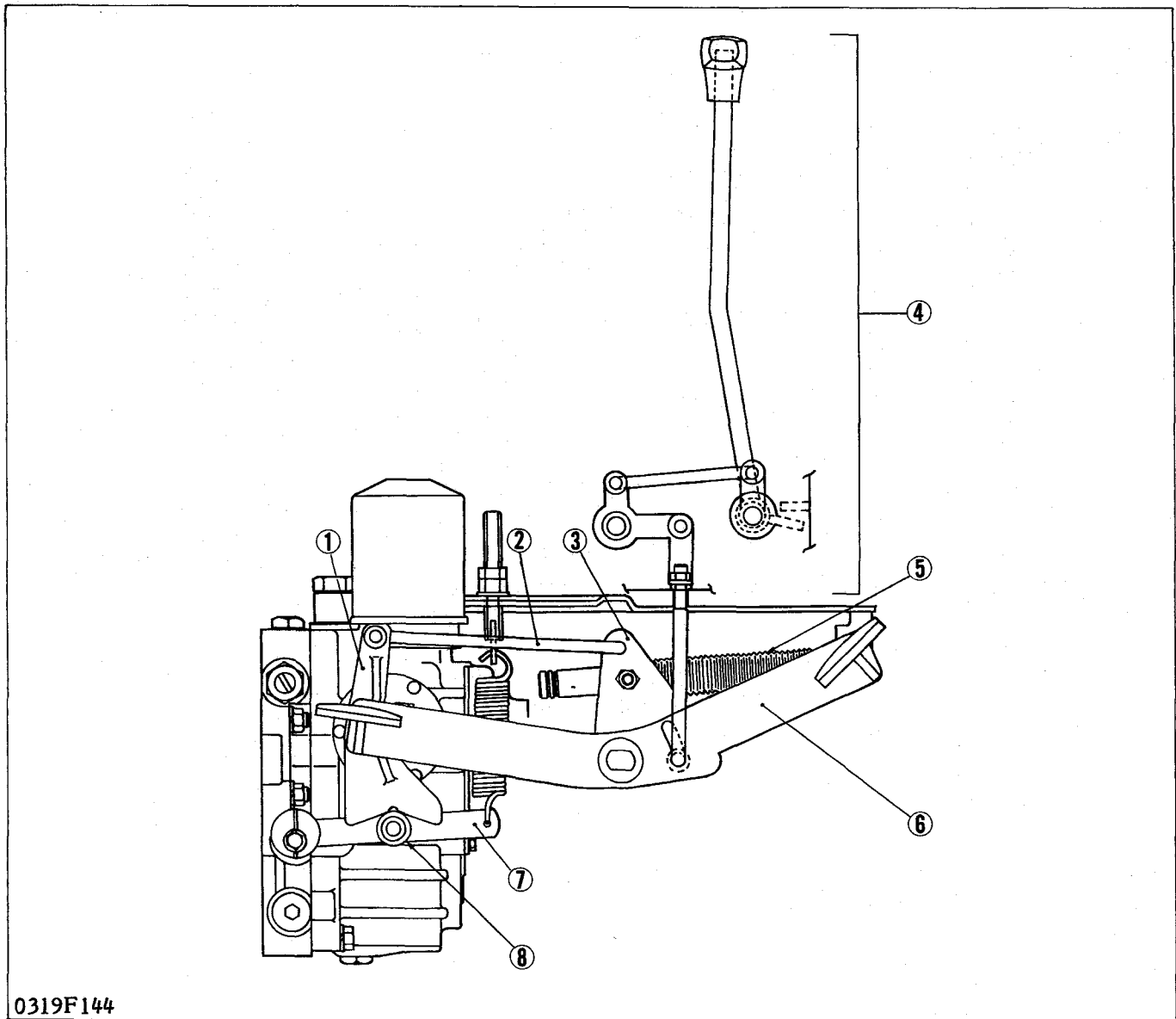

0319F144

(1) Neutral Holder  
 (2) Speed Control Rod  
 (3) Rod Guide

(4) Speed Set Device  
 (5) Damper  
 (6) Speed Control Pedal

(7) Neutral Holder Arm  
 (8) Roller

The speed control pedal (6) and the trunnion shaft of variable swashplate are linked with the rod guide (3), the speed control rod (2) and the neutral holder (1). As the front footrest of the pedal is depressed, the swashplate rotates and forward traveling speed increases. Depressing the rear footrest increases reverse speed.

The roller (8) on the neutral holder arm (7) hanged with spring seats the detent of the neutral holder (1) so that the neutral holder returns to neutral.

Then, the swashplate is returned to neutral with the neutral holder, when the pedal is released. The damper (5) connected to the rod guide (3) restricts the movement of the linkage to prevent abrupt operation or reversing.

The speed set device (4) linked to the rod guide (3) enables the linkage not to return to neutral and to keep a certain forward speed while the speed control pedal (6) is released.

On B6200HST, this device is installed as optional.

**[2] Mechanical Transmission****(1) High-Low Gear Shift Section**

Mechanical transmission receives engine power from the output shaft of hydrostatic transmission and selects high or low gear, and transmits the power to differential.

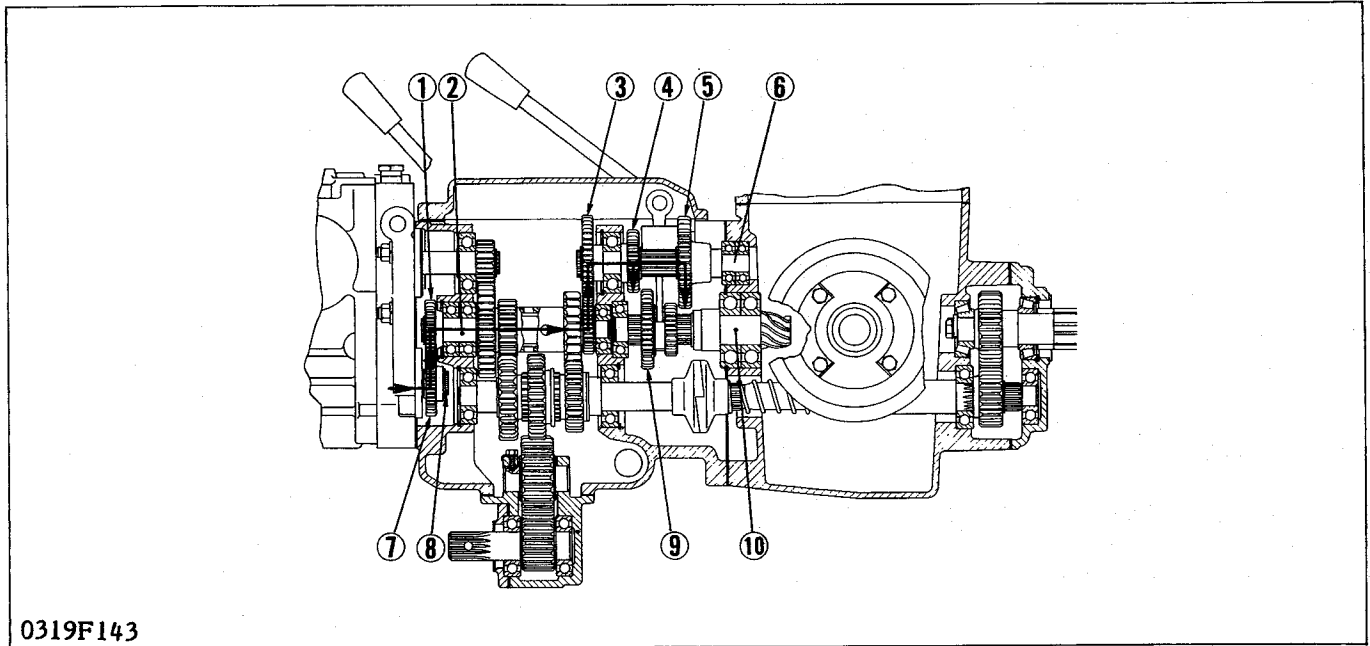
**■ Neutral**

0319F143

- (1) 14T Gear
- (2) 2nd Shaft
- (3) 24T Gear
- (4) 15T Gear

- (5) 23T Gear
- (6) 4th Shaft
- (7) 16T Gear
- (8) Output Shaft

- (9) 20T-12T Gear
- (10) Spiral Bevel Pinion

High or low speed is obtained by shifting 20T-12T gear (9) splined to spiral bevel pinion (10). When in neutral, neither 15T gear (4) nor 23T gear (5) meshes with 20T-12T gear (9) on spiral bevel pinion (10). Engine power is transmitted to the output shaft (8) of hydrostatic transmission, to which 16T gear (7) is splined.

16T gear (7) and 14T gear (1) are in mesh. 14T gear (1) is splined to 2nd shaft (2). Integral 11T gear on 2nd shaft (2) and 24T gear (3) are in mesh. 24T gear (3) is splined to 4th shaft (6). To 4th shaft (6), 15T gear (4) and 23T gear (5) are also splined. Spiral bevel pinion (10) is not driven.

■ Low

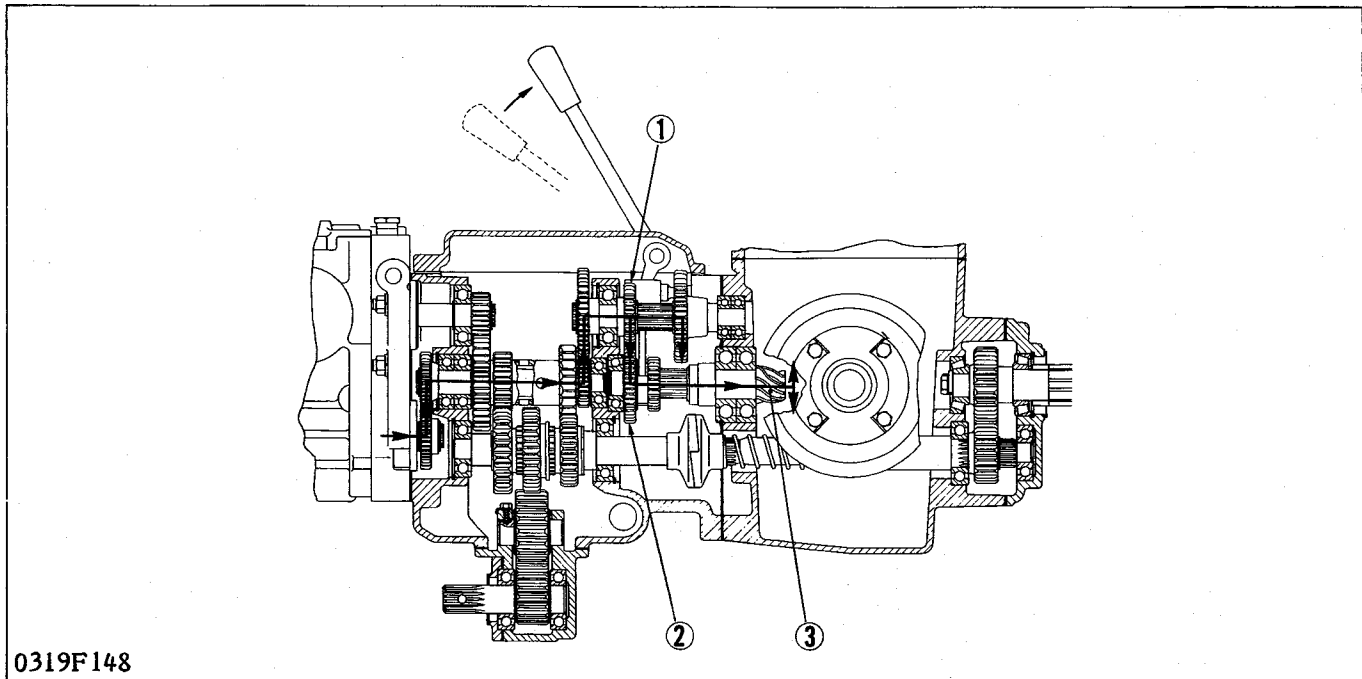

0319F148

(1) 15T Gear

(2) 20T-12T Gear

(3) Spiral Bevel Pinion

20T-12T gear (2) is shifted and 20T gear meshes with 15T gear (1) splined to spiral bevel pinion (3). Then power is transmitted to differential.

■ High

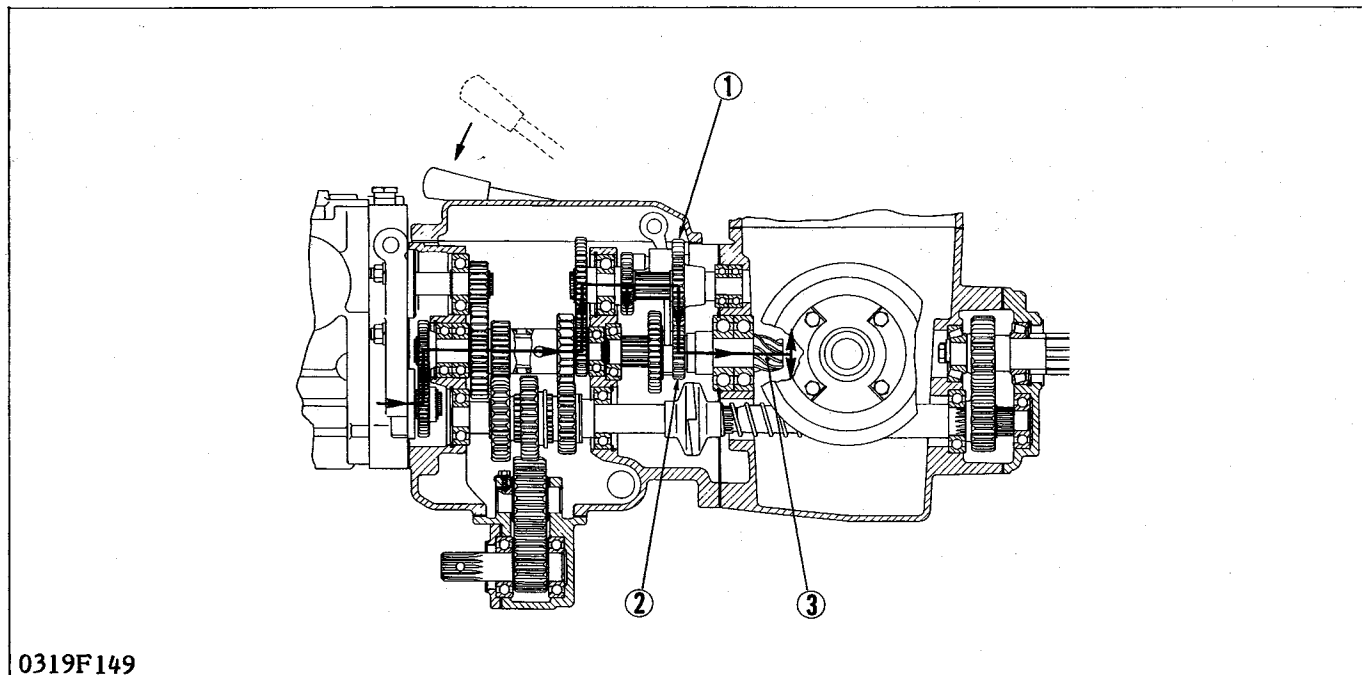

0319F149

(1) 23T Gear

(2) 20T-12T Gear

(3) Spiral Bevel Pinion

20T-12T gear (2) is shifted and 12T gear meshes with 23T gear (1) splined to spiral bevel pinion (3). Then power is transmitted to differential.

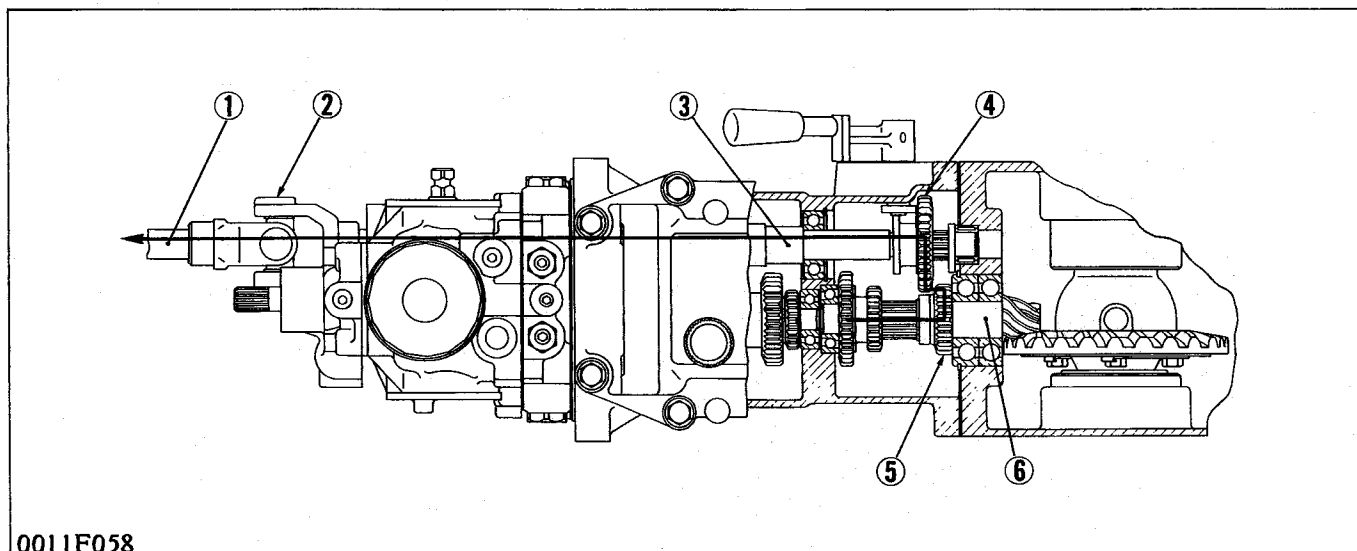
**(2) Front Wheel Drive Section (4WD Type)**

(1) Drive Shaft  
(2) Universal Joint

(3) Front Wheel Drive Shaft  
(4) 24T Gear

(5) 16T Gear  
(6) Spiral Bevel Pinion

The front wheel drive is used when greater traction power is required or to prevent the tractor from being pushed during rotary tilling of hard soil. 2-wheel drive or 4-wheel drive is selected by changing position of 24T gear (4) on the front wheel drive shaft (3) with the front drive lever. When the front drive lever is set to "Disengaged", 24T gear is in neutral and power is not transmitted to the front drive shaft.

When the front drive lever is set to "Engaged", 24T gear slides rearward to engage with 16T gear (5) on the spiral bevel pinion shaft (6). Therefore, the front drive shaft is actuated to drive the front wheels.



## (3) PTO Shift Section

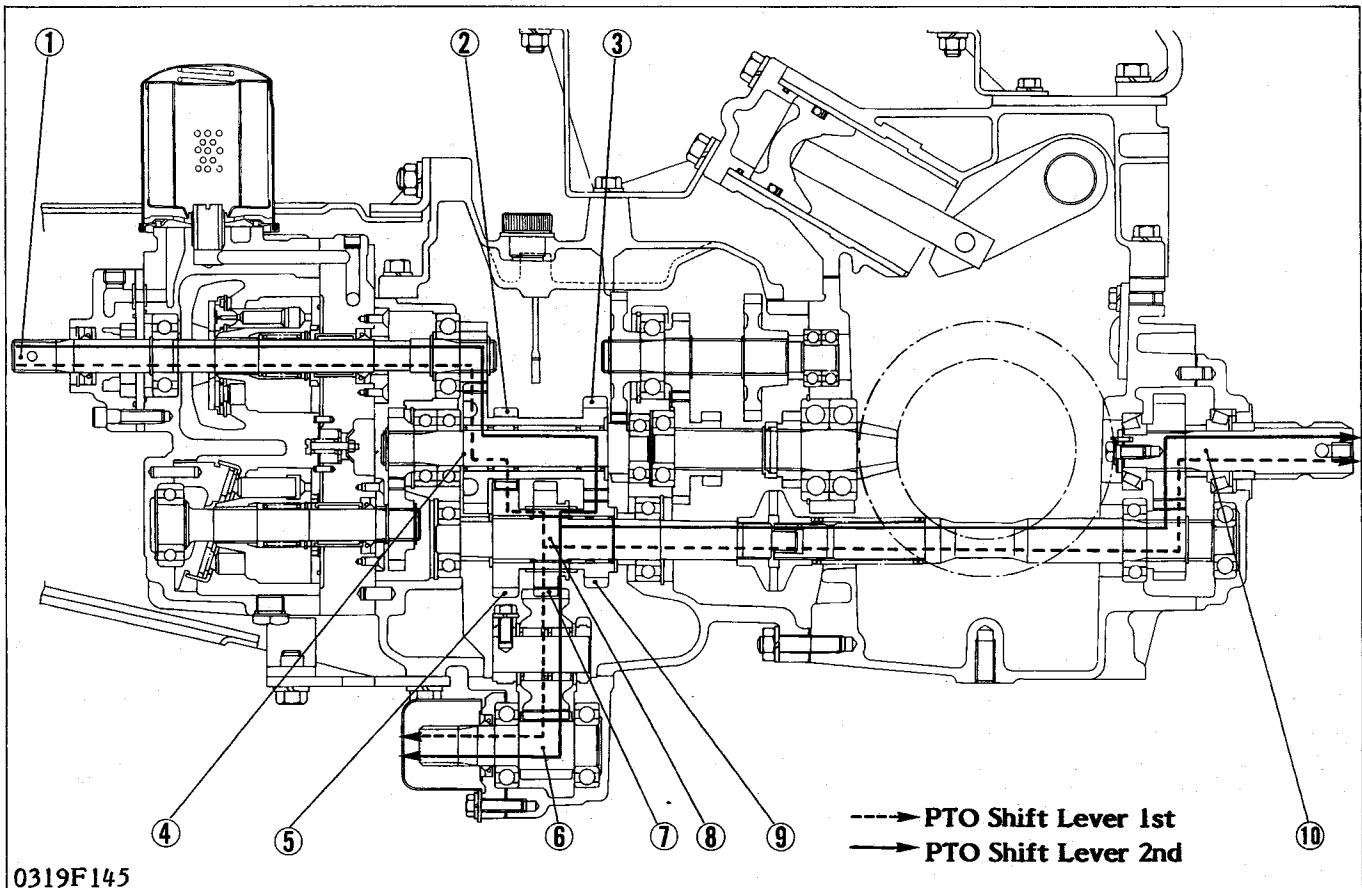

(1) Input Shaft of HST  
 (2) 14T Gear  
 (3) 18T Gear  
 (4) 2nd Shaft

(5) 21T Gear  
 (6) Mid PTO Shaft  
 (7) 21T Gear  
 (8) 3rd Shaft

(9) 17T Gear  
 (10) Rear PTO Shaft

PTO system is independent of HST. Engine revolution is directly transmitted to the 2nd shaft (4).

## 1) Neutral

The 14T gear (2) meshes with the 21T gear (5) on the 3rd shaft (8). And the 18T gear (3) meshes with the 17T gear (9) on the 3rd shaft (8), too. But the 21T gear (5) and the 17T gear (9) unite with needle bearing in itself, they run idle on the 3rd shaft (8). Then the 3rd shaft (8) is not driven.

## 2) 1st Position

The 21T gear (7) splined to the 3rd shaft (8) is shifted forward, and then the 3rd shaft (8) is rotated. The power train is shown in the figure above. Rear PTO shaft (10) speed is 540rpm at an engine speed of 2517rpm. Mid PTO shaft (6) speed is 1546rpm at an engine speed of 2517rpm.

## 3) 2nd Position

The 21T gear (7) shifted to the 3rd shaft (8) is shifted rearward, and then the 3rd shaft (8) is rotated. The power train is shown in the figure above. Rear PTO shaft (10) speed is 858rpm at an engine speed of 2517rpm. Mid PTO shaft (6) speed is 2456rpm at an engine speed of 2517rpm.

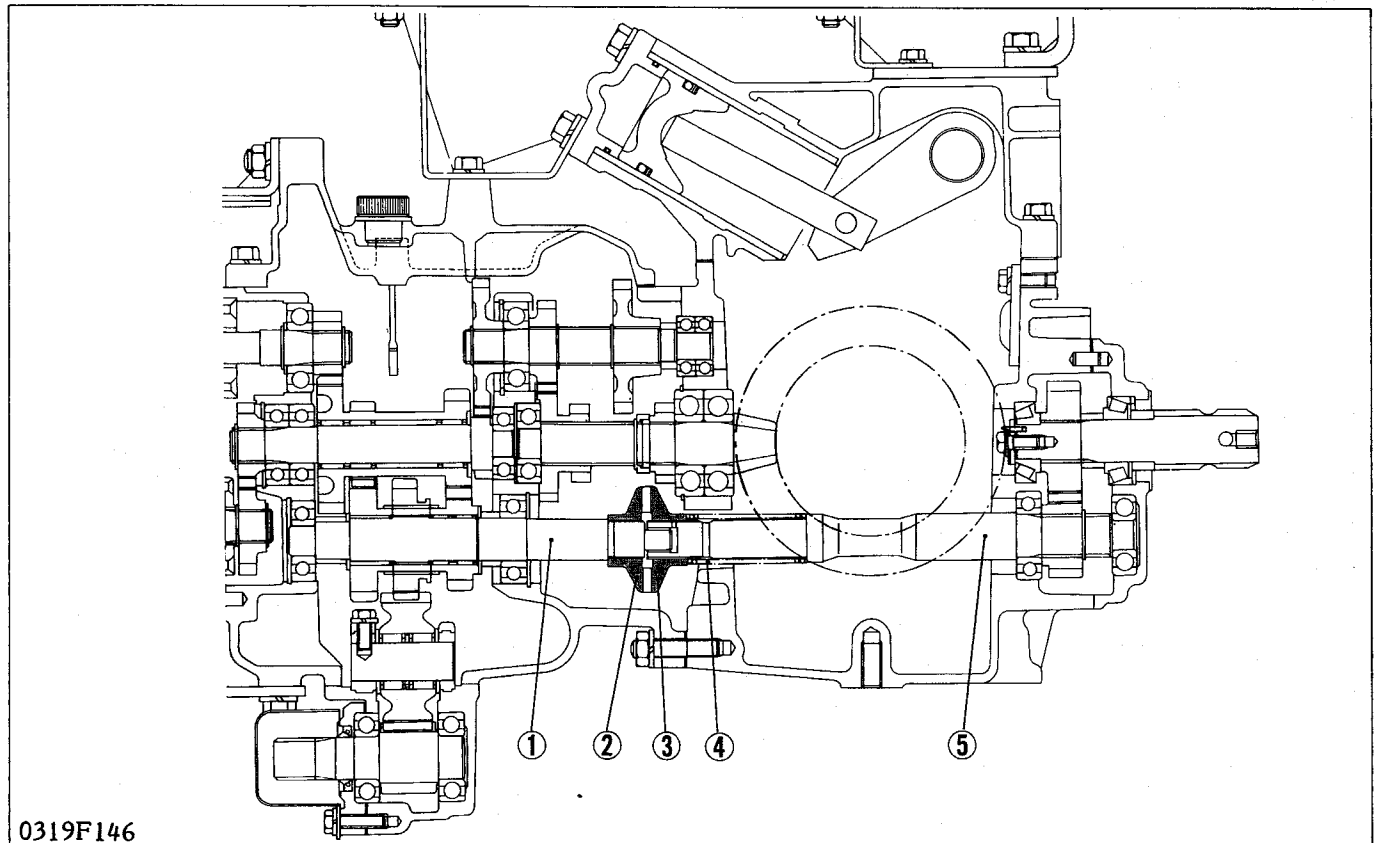
**(4) One-Way Clutch Cam Section**

0319F146

(1) 3rd Shaft  
(2) Clutch Cam

(3) Clutch Cam  
(4) Cam Spring

(5) 5th Shaft

The one-way clutch cam is also called an overrunning clutch. It is composed of a pair of clutch cams (2), (3) and a cam spring (4). One of the clutch cams is splined to the 3rd shaft (1), and the other is splined to the 5th shaft (5).

These two clutch cams are engaged with each other by the force of the cam spring. As long as the 3rd shaft is rotating faster than the 5th shaft, these two clutch cams will remain engaged, and the 5th shaft is driven.

# 7 HYDRAULIC SYSTEM

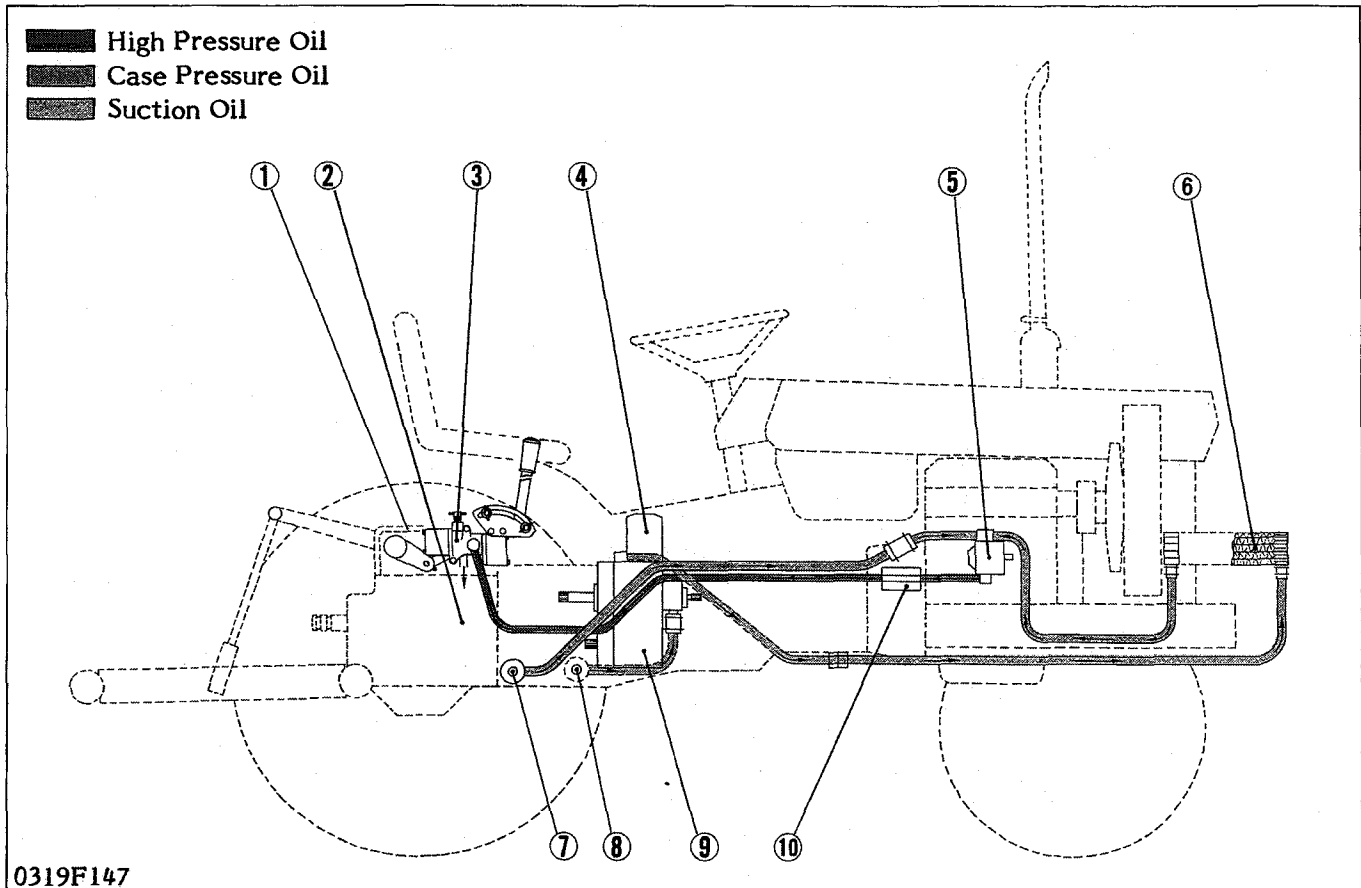

- (1) Case Rear Cover
- (2) Transmission Case
- (3) Control Valve
- (4) Oil Filter

- (5) Hydraulic Pump
- (6) Oil Cooler
- (7) Strainer
- (8) Strainer

- (9) Hydrostatic Transmission
- (10) Hydraulic Block Type Outlet

This tractor uses hydraulics to control mounted equipment and to transmit engine power for traveling.

Hydraulic system is composed of oil reservoir (transmission case) (2), strainers (7), (8), hydraulic pump (5), hydraulic block type outlet (10), control valve (3), integral lift arm cylinder of case rear cover (1), oil filter (4), hydrostatic transmission (9) and oil cooler (6).

Equipment control system is described here, but not hydraulic transmission system, which is referred to "TRANSMISSION".

Hydraulic oil is drawn from the bottom of transmission case (2) through the strainer (7) by the hydraulic pump (5) and fed to the control valve (3) through the hydraulic block type outlet (10). One relief valve is built in the control valve.

## [1] Oil Cooler

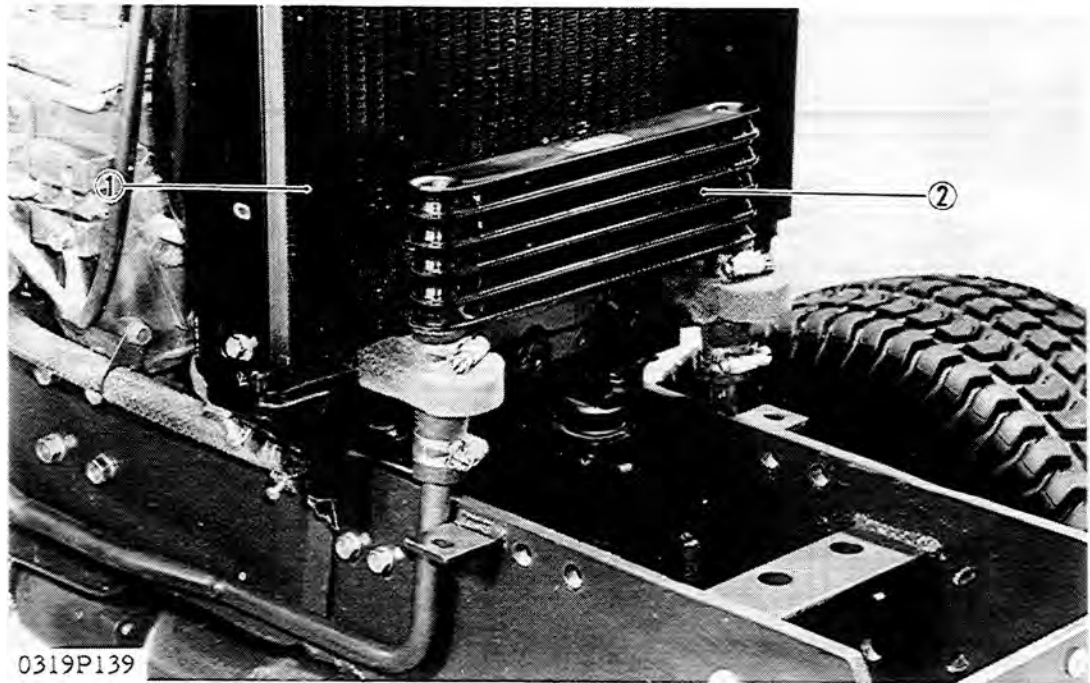

(1) Radiator

(2) Oil Cooler

Hydrostatic transmission produces the heat more than normal circulation of oil dissipates, then this tractor is equipped with a oil cooler.

The oil cooler is located in front of the engine radiator and of air-to-oil type, so that air blast by fan dissipates the heat from oil through the oil tubes with fin of the cooler.

# 8 ELECTRICAL SYSTEM

## [1] WIRING DIAGRAM AND ELECTRICAL CIRCUIT

### (1) Wiring Diagram

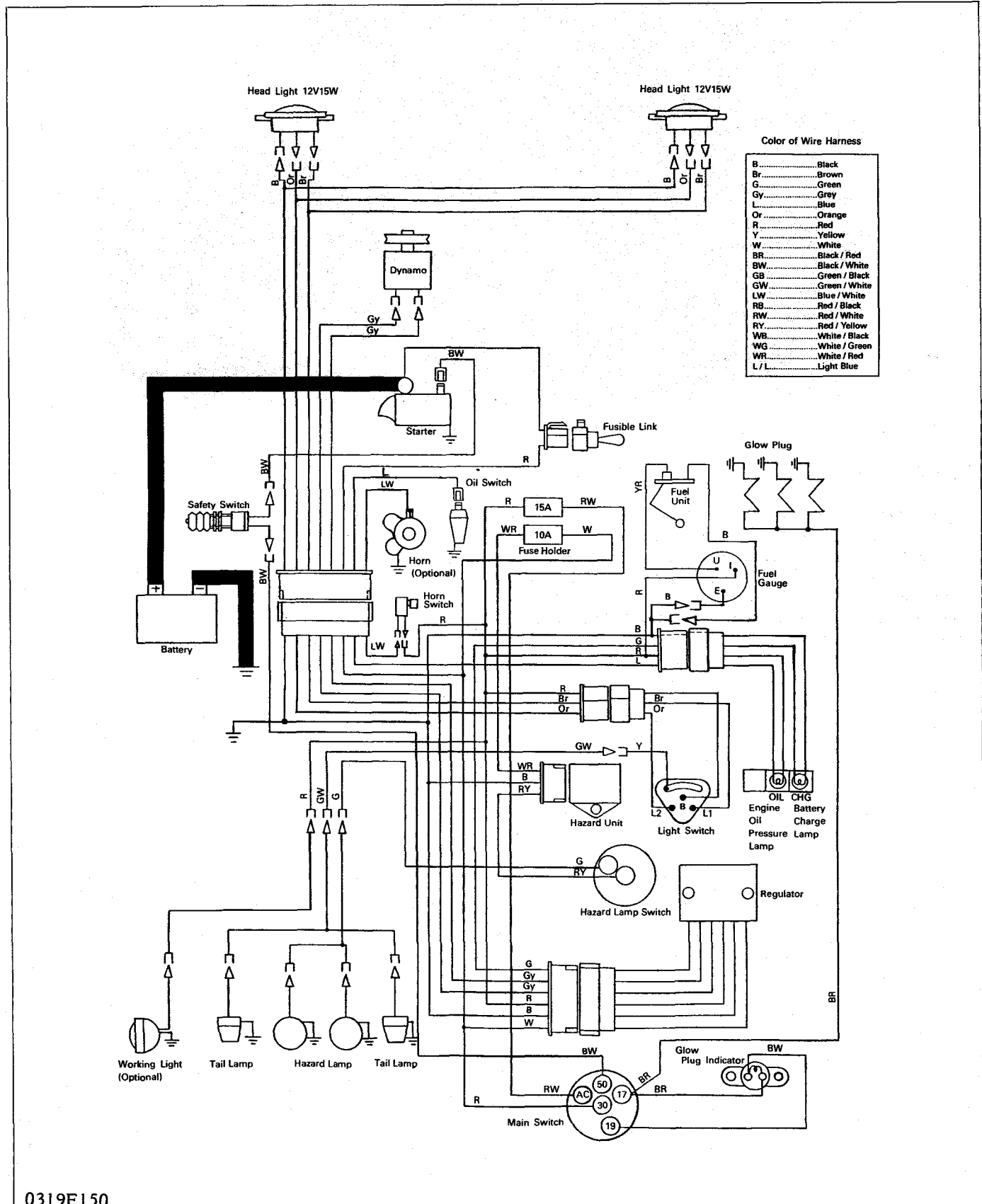

0319F150

# S.G GENERAL

[1] TRACTOR IDENTIFICATION.....	S.G-1
[2] GENERAL PRECAUTIONS.....	S.G-2
[3] LUBRICANTS.....	S.G-3
[4] TIGHTENING TORQUES.....	S.G-4
[5] MAINTENANCE CHECK LIST.....	S.G-5
[6] CHECK AND MAINTENANCE.....	S.G-6
(1) Check Points of Initial 35 Hours.....	S.G-6
(2) Check Points of Initial 50 Hours.....	S.G-7
(3) Check Points of Every 75 Hours.....	S.G-8
(4) Check Points of Every 100 Hours.....	S.G-9
(5) Check Points of Every 150 Hours.....	S.G-13
(6) Check Points of Every 300 Hours.....	S.G-14
(7) Check Points of Every 400 Hours.....	S.G-15
(8) Check Points of Every 500 Hours.....	S.G-15
(9) Check Points of Every One to Two.....	S.G-16
Months	
(10) Check Points of Every 3 Months.....	S.G-16
(11) Check Points of Every Year or.....	S.G-17
Every 6 Times of Cleaning	
(12) Check Points of Every Year.....	S.G-17
(13) Check Points of Every 2 Year.....	S.G-18
(14) Original Charge of Dry Type.....	S.G-19
Battery	
[7] SPECIAL TOOLS.....	S.G-20

**[1] TRACTOR IDENTIFICATION**

When contacting your local KUBOTA distributor, always specify tractor serial number and hourmeter reading.

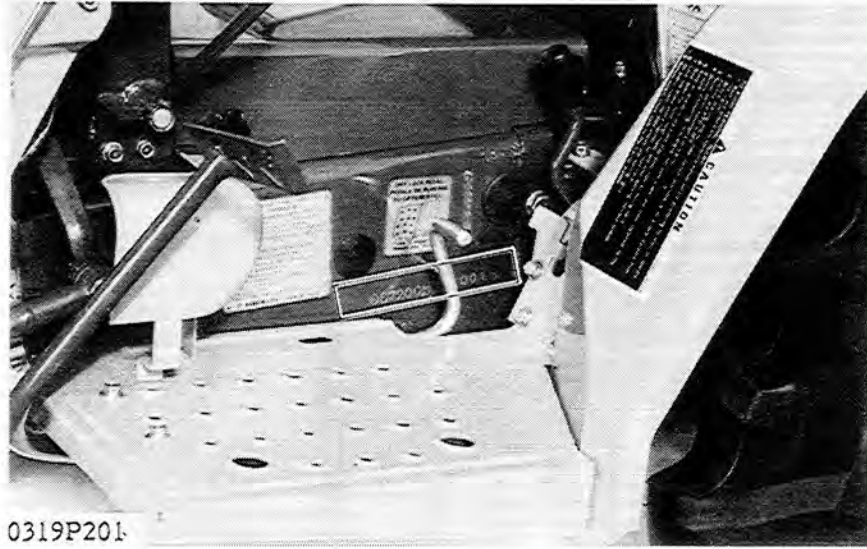

0319P201



0319P200

**[2] GENERAL PRECAUTIONS**

- During disassembly, carefully arrange removed parts in a clean area to prevent confusion later. Bolts and nuts should be installed in their original position to prevent reassembly errors.
- When special tools are required, use KUBOTA genuine special tools. Special tools which are not frequently used should be made according to the drawings provided.
- Before disassembling or servicing electrical wires, always disconnect the ground cable from the battery first.
- Remove oil and dirt from parts before measuring.
- Use only KUBOTA genuine parts for parts replacement to maintain tractor performance and to assure safety.
- Gaskets and O-rings must be replaced during reassembly. Apply grease to new O-ring or oil seals before assembling. See the figure below.
- When reassembling external circlips or internal circlips, they must be positioned so that sharp edge faces against the direction from which force is applied. See the figure below.
- When inserting spring pins, their splits must face the direction from which a force is applied. See the figure below.
- To prevent damage to the hydraulic system, use only specified fluid or equivalent.

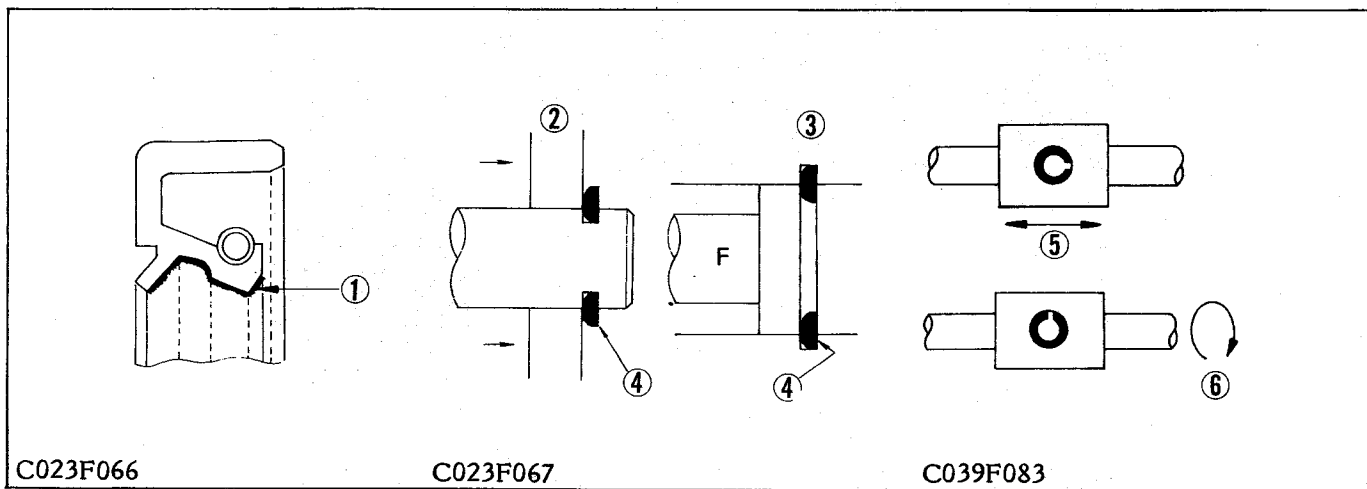

C023F066

C023F067

C039F083

(1) Grease

(2) External Circlip

(3) Internal Circlip

(4) Sharp Edge against the Direction of Force

(5) Axial Force

(6) Rotating Movement



## [3] LUBRICANTS

Place	Capacity	Lubricants
Engine crankcase	3.1 ℓ 3.3 U.S.qts. 2.73 Imp.qts.	<ul style="list-style-type: none"> <li>● Engine oil: API Service CC or CD Below 0°C (32°F).....SAE10W or 10W-30 0 to 25°C (32° to 77°F).....SAE20 or 10W-30 Above 25°C (77°F).....SAE30 or 10W-30</li> </ul>
Transmission	13.5 ℓ 14.3 U.S.qts. 11.9 Imp.qts.	<ul style="list-style-type: none"> <li>● The oil used to lubricate the transmission is also used as hydraulic fluid. To insure proper operation of the hydraulic system and complete lubrication of the transmission, it is important that a multi-grade transmission fluid is used in this system. The following are recommended oils, by brand name, that should be used in the transmission and hydraulic system. KUBOTA... UDT Hydraulic Transmission Fluid SHELL..... DONAX-TD, DONAX-TM Mobil..... Mobil Fluid 350 Exxon..... Torque Fluid 56</li> </ul>
Front axle case (B6200 HST 4WD Type)	0.5 ℓ 0.5 U.S.qts. 0.44 Imp.qts.	<ul style="list-style-type: none"> <li>● Gear oil SAE80 or SAE90</li> </ul>
Front axle arm (B7200 HST 4WD Type)	1.5 ℓ 1.6 U.S.qts. 1.32 Imp.qts.	<ul style="list-style-type: none"> <li>● Gear oil SAE80 or SAE90</li> </ul>
Gear case (B6200 HST 4WD Type)	0.15 ℓ 0.16 U.S.qts. 0.13 Imp.qts.	<ul style="list-style-type: none"> <li>● Gear oil SAE80 or SAE90</li> </ul>
Front axle case (B7200 HST 4WD Type)	0.5 ℓ 0.5 U.S.qts. 0.44 Imp.qts.	<ul style="list-style-type: none"> <li>● Gear oil SAE80 or SAE90</li> </ul>
Steering gear box (Manual steering)	0.2 ℓ 0.2 U.S.qts. 0.18 Imp.qts.	<ul style="list-style-type: none"> <li>● Gear oil SAE80 or SAE90</li> </ul>
King pins (2WD Type) Center pin (2WD Type) Brake pedal shaft Clutch pedal shaft Cluth release hub Seat adjuster Speed control pedal shaft	Moderate amount	SAE multi-purpose type grease

**[4] TIGHTENING TORQUES****1) Tightening torques for general use screws, bolts and nuts**

Screws, bolts and nuts whose tightening torques are not specified in the Workshop Manual should be tightened according to the table below.

Material Nominal diameter	Unit	No-grade			7T			9T		
		SS41, S20C			S43C, S48C (Quenched and Tempered)			SCr435, SCM435 (Quenched and Tempered)		
		N·m	kgf·m	ft·lbs	N·m	kgf·m	ft·lbs	N·m	kgf·m	ft·lbs
M 6 (M 6)		7.84 to 9.31 (7.84to8.82)	0.80 to 0.95 (0.80to0.90)	5.79 to 6.87 (5.79to6.51)	9.80 to 11.2 (7.84to8.82)	1.00 to 1.15 (0.80to0.90)	7.24 to 8.32 (5.79to6.51)	12.3 to 14.2 —	1.25 to 1.45 —	9.05 to 10.5 —
M 8 (M 8)		17.7 to 20.6 (16.7to19.6)	1.80 to 2.10 (1.70to2.00)	13.0 to 15.2 (12.3to14.5)	23.6 to 27.4 (17.7to20.6)	2.40 to 2.80 (1.80to2.10)	17.4 to 20.2 (13.0to15.2)	29.4 to 34.3 —	3.00 to 3.50 —	21.7 to 25.3 —
M10 (M10)		39.2 to 45.0 (31.4to34.3)	4.00 to 4.60 (3.20to3.50)	29.0 to 33.2 (23.2to25.3)	48.1 to 55.8 (34.3to39.2)	4.90 to 5.70 (3.50to4.00)	35.5 to 41.2 (25.4to28.9)	60.8 to 70.5 —	6.20 to 7.20 —	44.9 to 52.1 —
M12 (M12)		62.8 to 72.5 —	6.40 to 7.40 —	46.3 to 53.5 —	77.5 to 90.1 (73.5to78.4)	7.90 to 9.20 (7.50to8.00)	57.2 to 66.5 (54.3to57.8)	103 to 117 —	10.5 to 12.0 —	76.0 to 86.8 —
M14		108 to 125	11.0 to 12.8	79.6 to 92.5	124 to 147	12.6 to 15.0	91.2 to 108	167 to 196	17.0 to 20.0	123 to 144
M16		167 to 191	17.0 to 19.5	123 to 141	196 to 225	20.0 to 23.0	145 to 166	260 to 303	26.5 to 31.0	192 to 224
M18		245 to 284	25.0 to 29.0	181 to 210	275 to 318	28.0 to 32.5	203 to 235	343 to 401	35.0 to 41.0	254 to 297
M20		334 to 392	34.0 to 40.0	246 to 289	368 to 431	37.5 to 44.0	272 to 318	490 to 568	50.0 to 58.0	362 to 420

**■ NOTE**

- Figures in parentheses must be selected when the material of the mating thread is aluminum.

## [5] MAINTENANCE CHECK LIST

Service Interval	Check Points	Reference Page
Initial operation (initial 60 hours)	During this period, pay special attention to the following. <ul style="list-style-type: none"> <li>●After the initial 35 hours of use, change the engine oil and the oil filter cartridge.</li> <li>●After the initial 50 hours of use, change the transmission oil and the oil filter cartridge and clean the oil strainer.</li> <li>●Quick starts or sudden braking should be avoided.</li> </ul>	S.G-6 S.G-7
Every 75 hours	Change engine oil.	S.G-8
Every 100 hours	Lubricate the following points: <ul style="list-style-type: none"> <li>●King pins (2WD Type)</li> <li>●Center pin (2WD Type)</li> <li>●Clutch pedal shaft</li> <li>●Brake pedal shaft</li> <li>●Speed control pedal shaft</li> <li>●Clutch release hub</li> </ul> Check the following points to be connected securely. <ul style="list-style-type: none"> <li>●Hydraulic inlet line clamps</li> <li>●Fuel line clamps</li> </ul> Clean air cleaner element. Clean fuel filter. Check battery electrolyte level. Check fuel line. Check fan drive belt tension. Check clutch pedal play. Check brake pedal play. Check steering wheel play.	S.G-9 S.G-9 S.G-9 S.G-9 S.G-9 S.G-9 S.G-10 S.G-10 S.G-10 S.G-11 S.G-11 S.G-11 S.G-11 S.G-12 S.G-12 S.G-13 S.G-13
Every 150 hours	Replace engine oil filter cartridge. Check water pipes and clamps.	S.G-14 S.G-14
Every 200 hours	Replace transmission oil filter cartridge.	S.G-14
Every 300 hours	Change transmission oil. Change front axle case oil (4WD Type). ●Clean transmission strainer.	S.G-15 S.G-15,16 S.G-7
Every 400 hours	Replace fuel filter.	S.G-15
Every 500 hours	Clean radiator interior.	S.G-16
Every one to two months	Recharge battery if necessary.	S.G-17
Every 3 months	Change scale inhibitor and coolant.	S.G-17
Every year or every 6 times of cleaning	Replace air cleaner element.	S.G-18
Every year	Change anti-freeze and coolant.	S.G-18
Every 2 years	Replace battery, if necessary. Replace water pipes and clamps. Replace fuel line and clamps. Replace hydraulic hoses and clamps.	S.G-19 S.G-19 S.G-19 S.G-20
Every 800 hours	Check valve clearance.	S.G-20

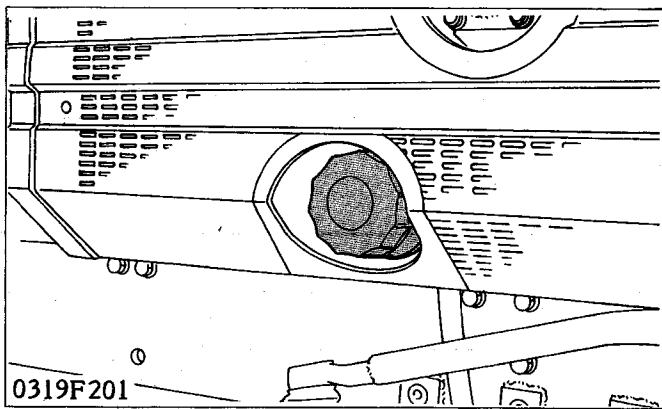
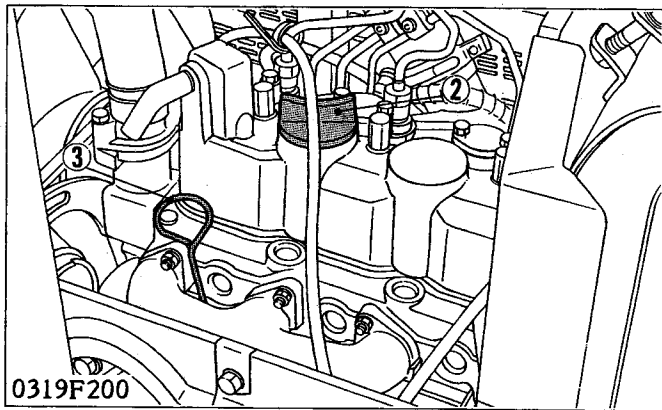
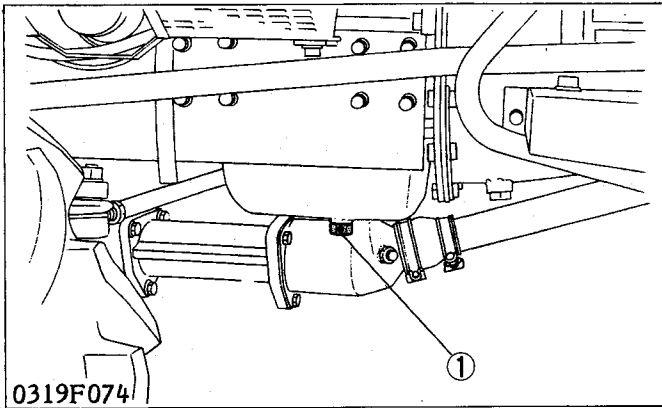
**[6] CHECK AND MAINTENANCE****(1) Check Points of Initial 35 Hours****Changing Engine Oil**

1. Start and warm up the engine for approx. 5 minutes.
  2. Remove the drain plug (1) to drain oil.
  3. Screw in the drain plug.
  4. Fill new oil up to the upper line on the dipstick (3).
- Refer to "LUBRICANTS". (See page S.G-3)

- (1) Drain Plug  
 (2) Oil Port Plug  
 (3) Dipstick

**Replacing Engine Oil Filter Cartridge****⚠ CAUTION**

- Be sure to stop the engine before replacing the oil filter cartridge.
1. Remove the engine oil filter cartridge.
  2. When installing, apply engine oil slightly to the rubber gasket.
  3. To install a new cartridge, screw it in by hand. Overtightening may deform the rubber gasket.
  4. After the cartridge has been replaced, the engine oil normally decreases a little. So replenish engine oil up to the specified level.

**■ IMPORTANT**

- To prevent serious damage to the engine, the element must be highly efficient. Use only genuine filters.

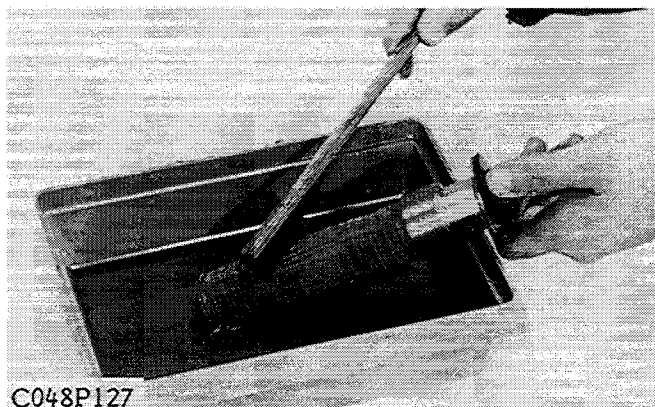
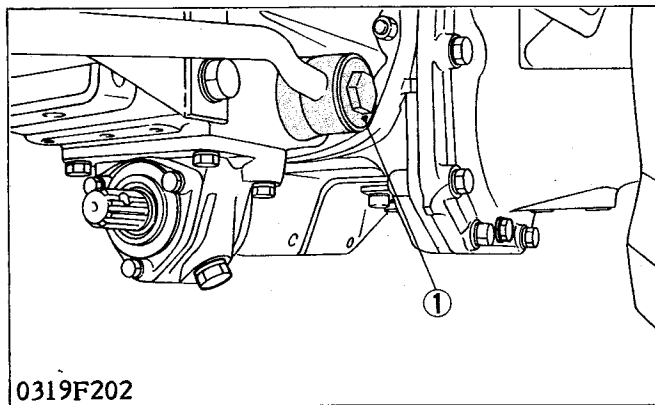
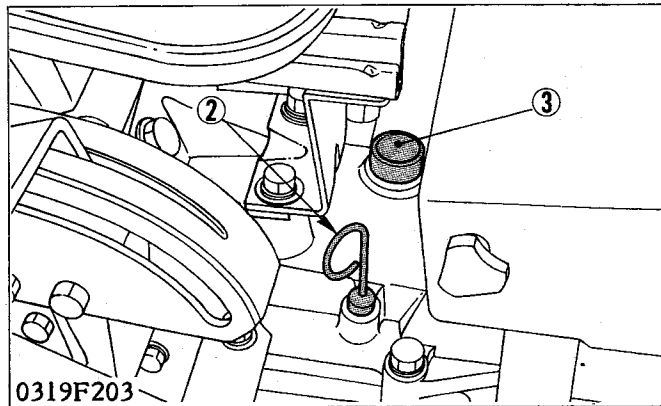
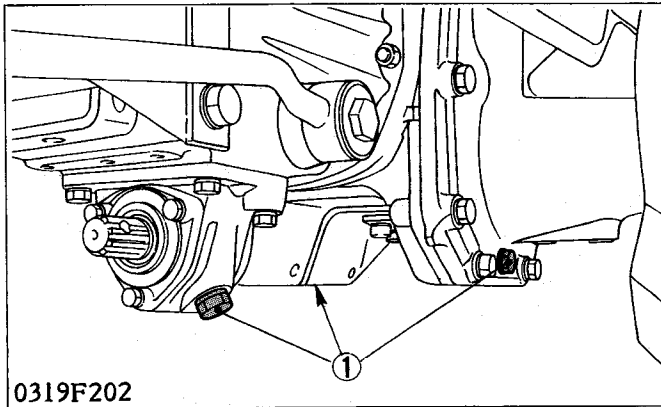
**(2) Check Points of Initial 50 Hours****Changing Transmission Oil**

1. Remove the drain plugs (1) to drain transmission oil.
2. Screw in the drain plugs.
3. Fill new oil up to the upper line on the dipstick (2).

**■ IMPORTANT**

- Use only multi-grade transmission fluid. Use of other oils may damage the transmission or hydraulic system. Refer to "LUBRICANTS". (See page S.G-3)

- (1) Drain Plug  
 (2) Dipstick  
 (3) Oil Port Plug

**Cleaning Oil Strainer**

1. Remove the oil strainer (1).
2. Rinse the oil strainer with kerosene to completely clean off dust.

- (1) Oil Strainer

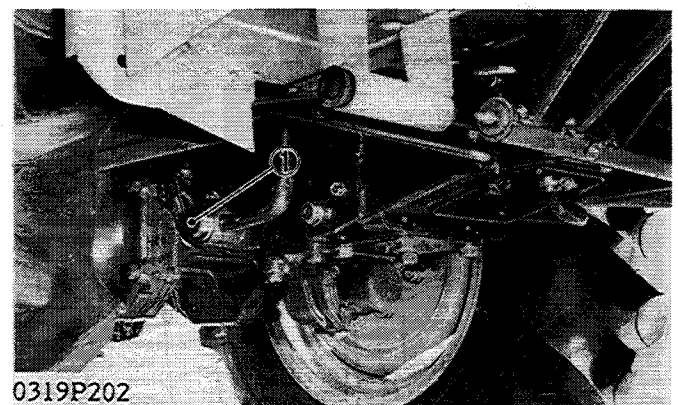

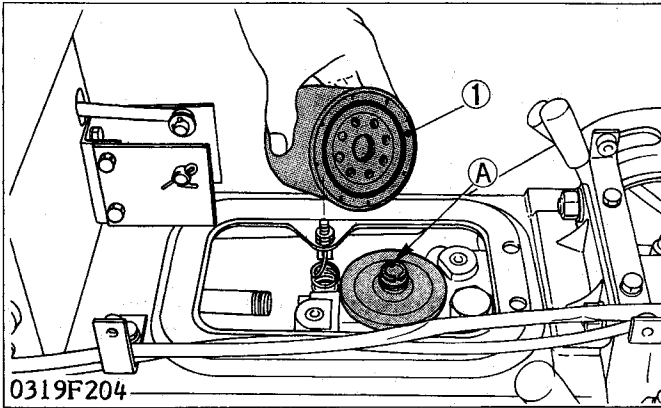

### Replacing Transmission Oil Filter Cartridge

#### ⚠ CAUTION

- Be sure to stop the engine before replacing the oil filter cartridge.
1. The oil filter cartridge must be replaced after initial 50 hours and every 200 service hours.
  2. Remove the 4 bolts which secure the cover.
  3. Remove the oil filter cartridge by using the filter wrench.
  4. Lightly tighten the screw (A) by using a screwdriver.
  5. Apply a slight coat of oil onto the cartridge gasket.
  6. To install the new cartridge, screw it in by hand. Over tightening may cause deformation of rubber gasket.
  7. After the new cartridge has been replaced, the transmission oil level will become a little lower. Make sure that the transmission oil does not leak through the seal. Check the oil level.

#### (1) Filter Cartridge

#### ■ IMPORTANT

- To prevent serious damage to hydraulic system, replacement of filter must be a highly efficient, 10  $\mu\text{m}$  filter. Use only a KUBOTA genuine filter or its equivalent.
- When using the auxiliary hydraulics, replace the transmission oil filter cartridge after initial 50 service hours.

### (3) Check Points of Every 75 Hours

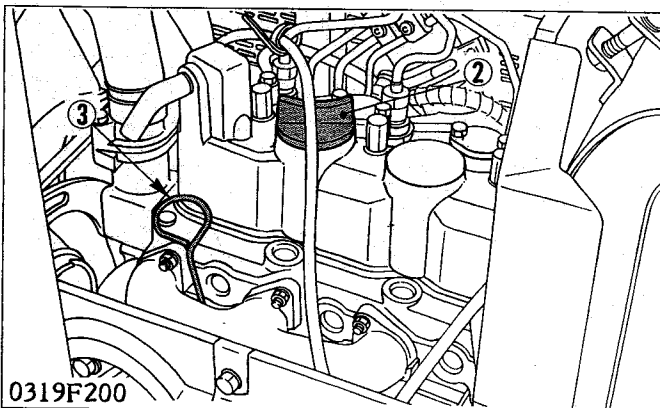
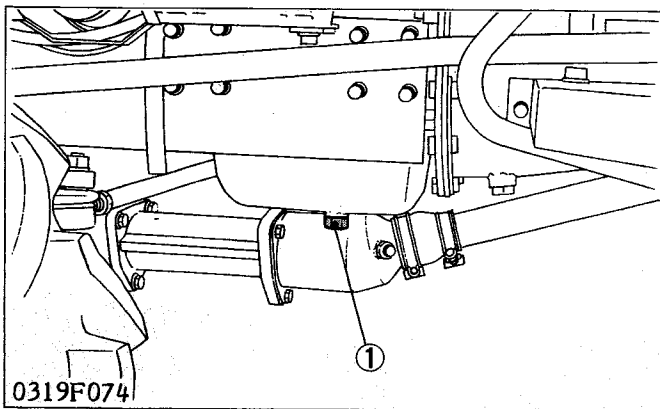

### Changing Engine Oil

1. See page S.G-6.

- (1) Drain Plug
- (2) Oil Port Plug
- (3) Dipstick

**(4) Check Points of Every 100 Hours**

**Greasing Points**

1. Grease the following points.

- King pins (2WD Type)
- Center pin (2WD Type)
- Clutch pedal shaft
- Brake pedal shaft
- Speed control pedal shaft
- Clutch release hub

● King Pins

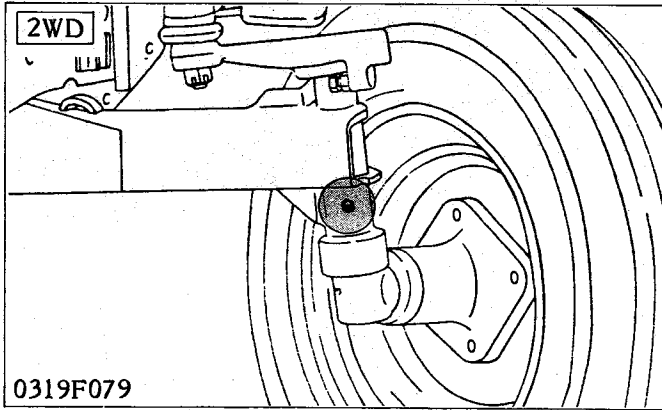

● Center Pin

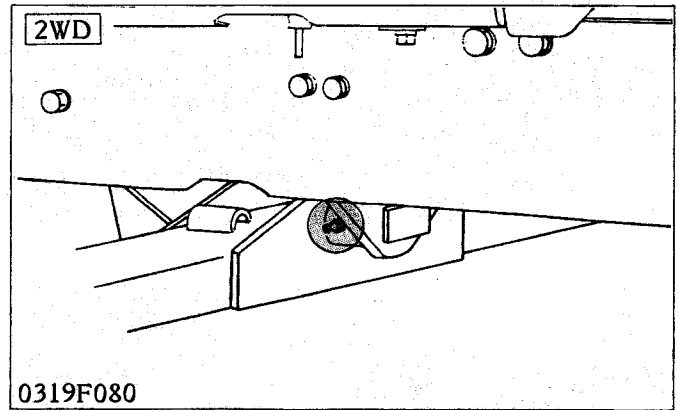

● Clutch Pedal Shaft

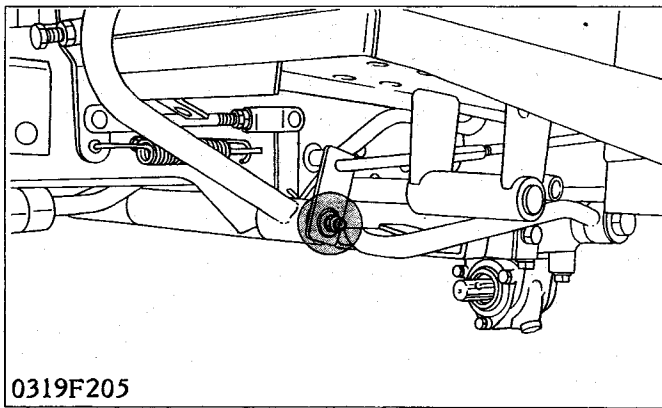

● Brake Pedal Shaft

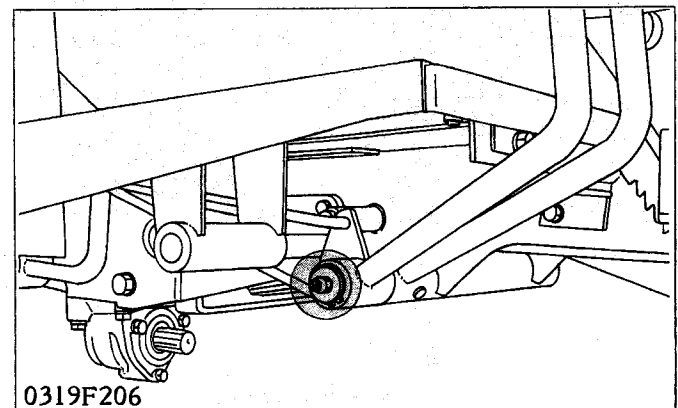

● Speed Control Pedal Shaft

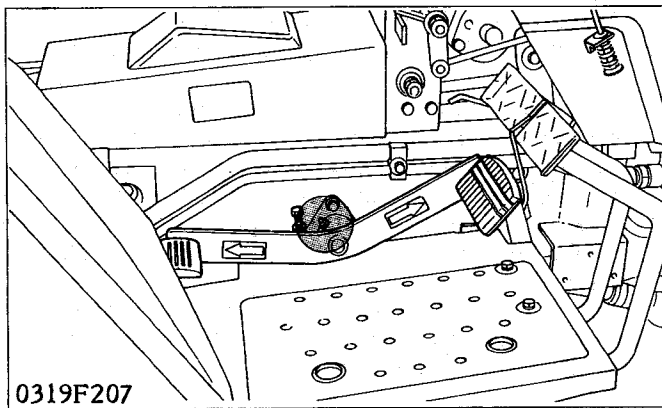

● Clutch Release Hub

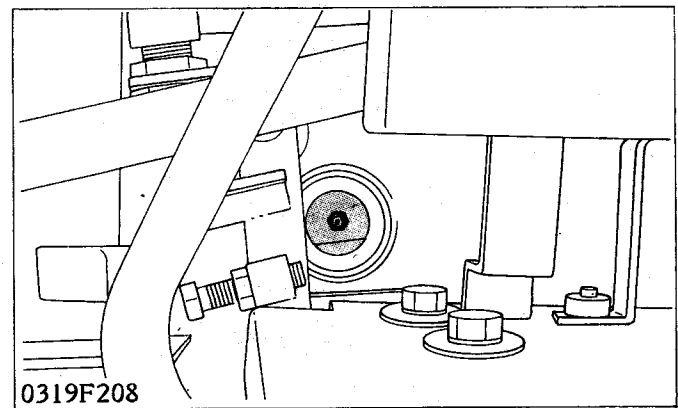

**Checking Clamps**

1. Check the following points to be connected securely.

- Hydraulic inlet line clamps
- Fuel line clamps

- Hydraulic Inlet Line Clamps

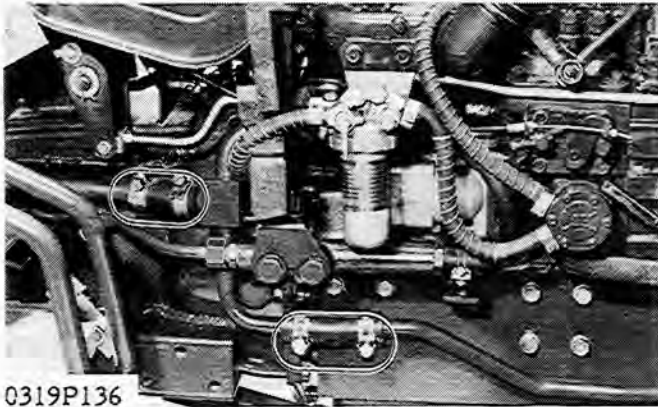

0319P136

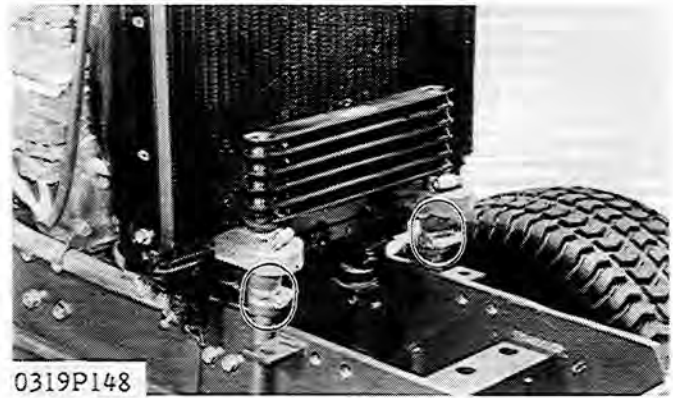

0319P148

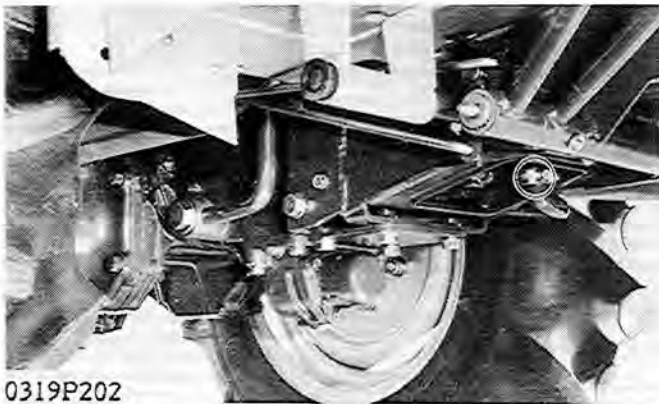

0319P202

- Fuel Line Clamps

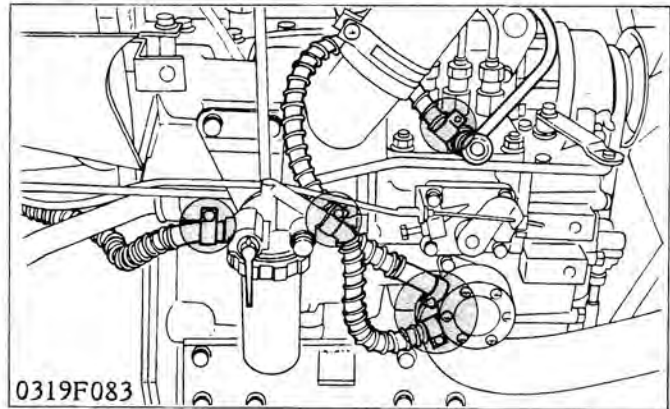

0319F083



C047F050

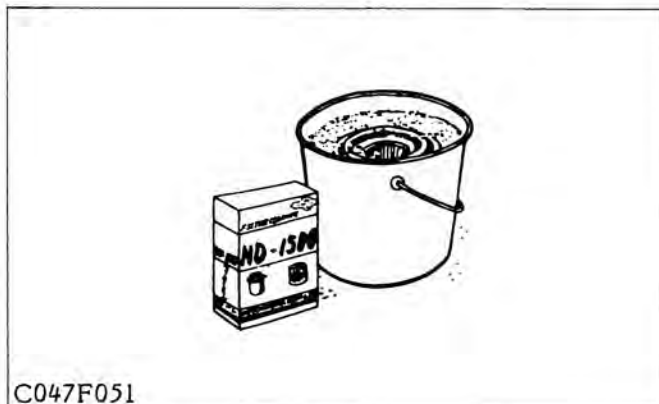

C047F051

**Cleaning Air Cleaner Element**

1. To clean the element, use clean dry compressed air on the inside of the element. Air pressure at the nozzle must not exceed 205 kPa (2.1 kgf/cm<sup>2</sup>, 30 psi).  
Maintain reasonable distance between the nozzle and the element.
2. To wash the element, use KUBOTA Filter of Donaldson ND-1500 Filter Cleaner which is especially effective on oily and soot-laden filters.

To use: Dissolve KUBOTA Filter Cleaner in a concentrated solution of cold water. When granules are thoroughly mixed, add water to make a solution equivalent to 15 g KUBOTA Filter Cleaner for each 1 little (1 quart) of water. (2 oz KUBOTA Filter Cleaner for each 1 gallon of water.)

Allow element to soak 15 minutes. Then agitate element to dislodge loosened dust-rinse in clear water-allow element to dry.



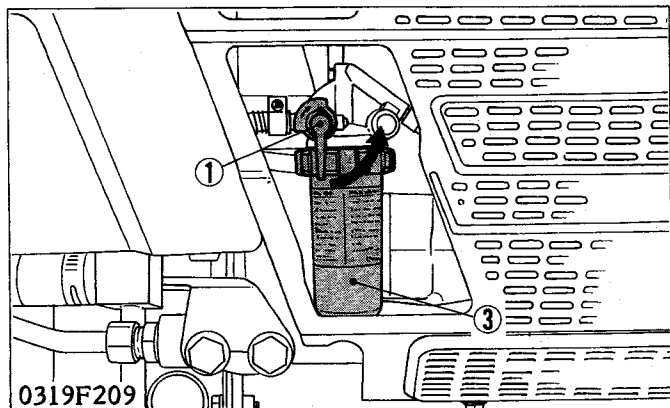

**Cleaning Fuel Filter**

1. Close the fuel filter cock (1).
2. Unscrew the screw ring (4) and remove the filter bowl (3), and rinse the inside with kerosene.
3. Take out the element (2) and dip it in the kerosene to rinse.
4. After cleaning, reassemble the fuel filter, keeping out dust and dirt.

**IMPORTANT**

- If dust and dirt enter the fuel, the injection pump and injection nozzle are subject to quick wear. To prevent this, be sure to clean the fuel filter bowl periodically.

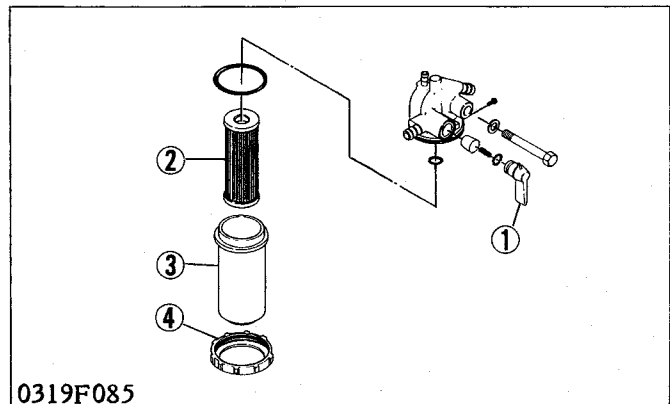

- (1) Fuel Filter Cock
- (2) Element
- (3) Filter Bowl
- (4) Screw Ring

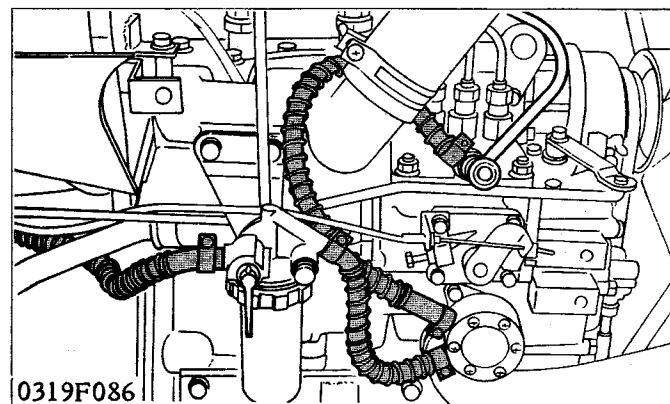

**Checking Fuel Line**

**CAUTION**

- Stop the engine when attempting the check as prescribed below.
- Never fail to check the fuel line periodically. The fuel line is subject to wear and aging, fuel may leak out onto the running engine, causing a fire.

1. Check the fuel line.
2. If the clamp is loose, apply a slight coat of lubricant onto the threads and securely retighten it.
3. If the fuel pipe and clamp are found damaged or deteriorated, replace or remedy.

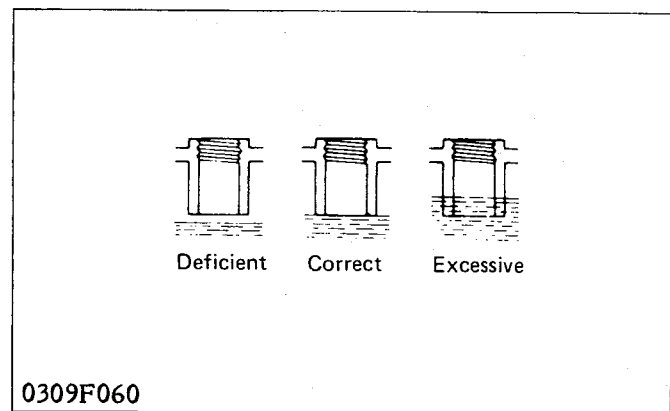

**Checking Battery Electrolyte Level**

**CAUTION**

- Never remove the battery cap while the engine is running.
- Keep electrolyte away from eyes, hands and clothes. If you are spattered with it, wash it away completely with water.

1. Check that the battery electrolyte level is between the lowest and highest levels.
2. If insufficient, add distilled water.

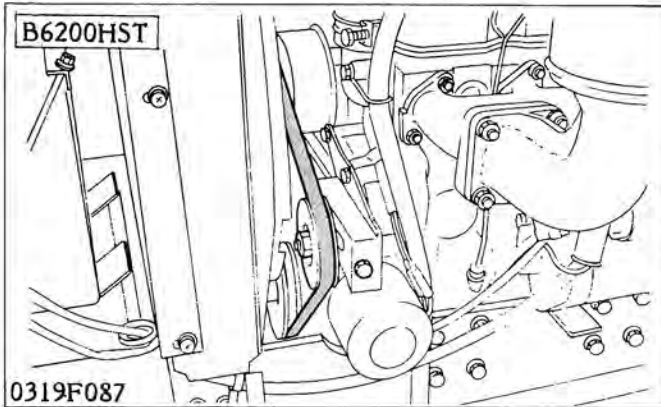

### Checking Fan Drive Belt Tension

1. Press the fan drive belt with a force of approx. 58.8 to 68.6 N (6 to 7 kgf, 13.2 to 15.4 lbs), and measure the deflection.
2. If the measurement is not the factory specification, adjust the fan drive belt tension.

#### Fan drive belt tension

Factory specification..... 7 to 9 mm  
0.276 to 0.354 in.

#### ■ NOTE

- When the tractor is stored for long periods, be sure to loosen the fan drive belt.

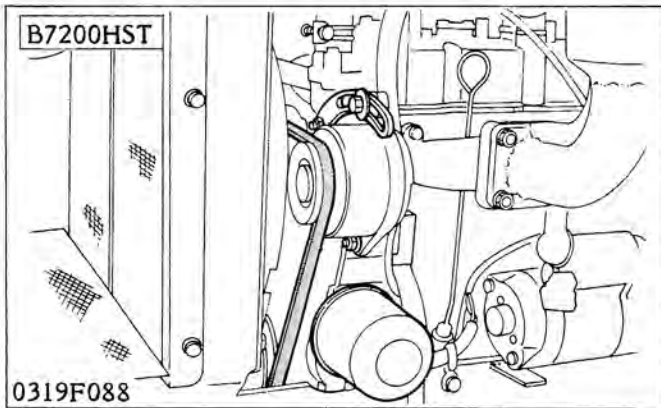

### Checking Clutch Pedal Play

1. Depress the clutch pedal by hand, and measure the amount of pedal movement at the footrest.
2. If the measurement is not within the factory specifications, adjust the play by changing the length of rod (1).

#### Clutch pedal play

Factory specification..... 20 to 30 mm  
0.79 to 1.18 in.

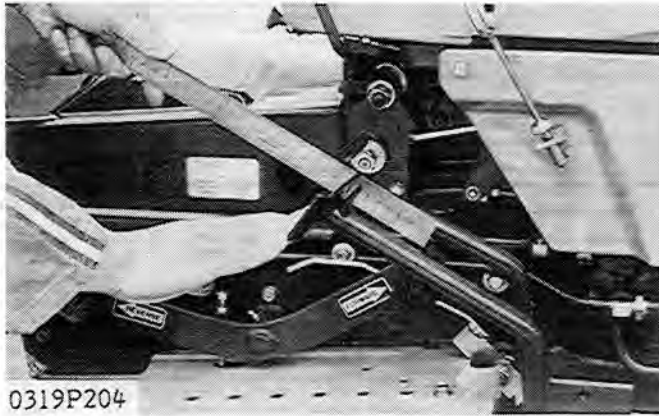

0319P204

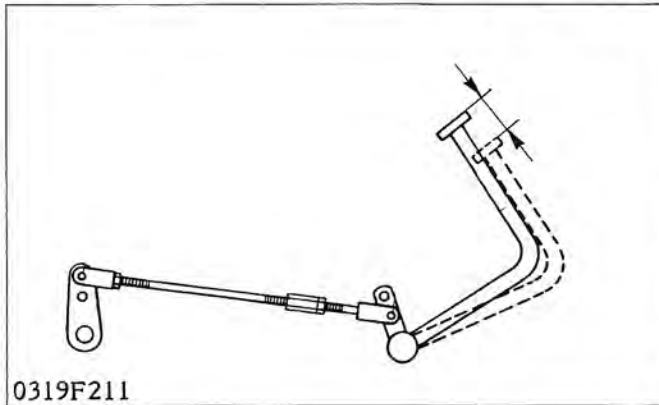

0319F211

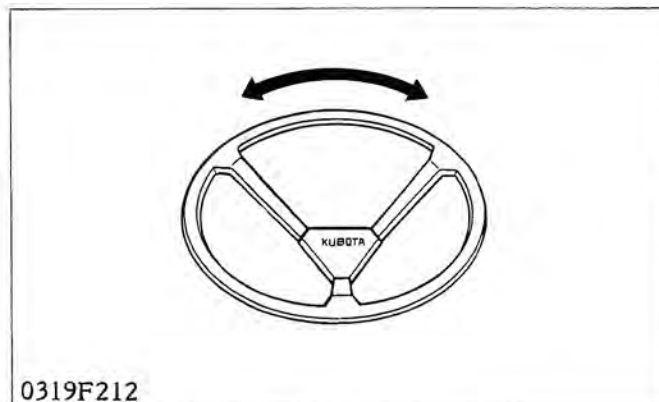

0319F212



0319P205

### Checking Brake Pedal Play

1. Press each of brake pedals five times with a force of 147 to 294 N (15 to 30 kgf, 33 to 66 lbs).
2. Press the center of the pedal at a force of 39 to 58 N (4 to 6 kgf, 9 to 13 lbs), and measure the movement at the footrest of pedal.
3. If the measurement is not within the factory specifications, turn the turnbuckle of brake rod to adjust.

#### Brake pedal play

Factory specification..... 20 to 30 mm  
0.79 to 1.18 in.

#### NOTE

- The difference between the left and right pedal plays must be less than 4 mm (0.157 in.).
- After adjustment, secure the turnbuckle with the lock nut.

### Checking Steering Wheel Play

1. Turn the front wheels straight ahead.
2. Measure the play with a scale.
3. If the measurement is not within the factory specifications, loosen the lock nut, and turn the adjusting screw with a screwdriver to adjust.

#### Play of steering wheel

Factory specification..... 20 to 50 mm  
0.79 to 1.96 in.

#### NOTE

- When the play is excessive, turn the adjusting screw clockwise, and when too little, counterclockwise.
- After adjustment, secure the adjusting screw with the lock nut.

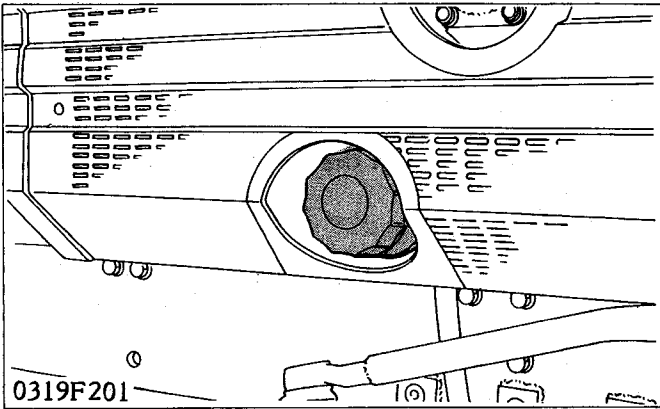
**(5) Check Points of Every 150 Hours****Replacing Engine Oil Filter Cartridge**

1. See page S.G-6.

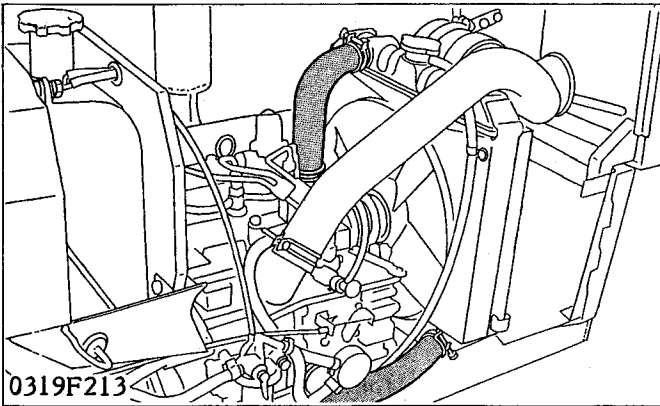
**Checking Water Pipes and Clamps**

1. Check the water pipes and the clamps.
2. If the clamp is loose, apply a slight coat of lubricant onto the threads and securely retighten it.
3. If the water pipe and clamp are found damaged or deteriorated, replace or remedy.

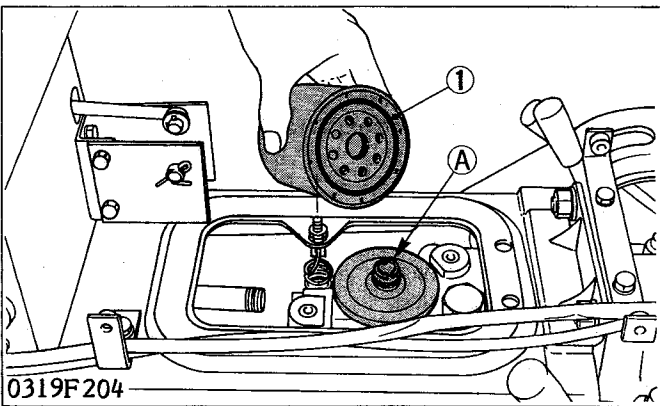
**(6) Check Points of every 200 Hours****Replacing Transmission Oil Filter Cartridge**

1. See page S.G-8.

**(7) Check Points of Every 300 Hours**

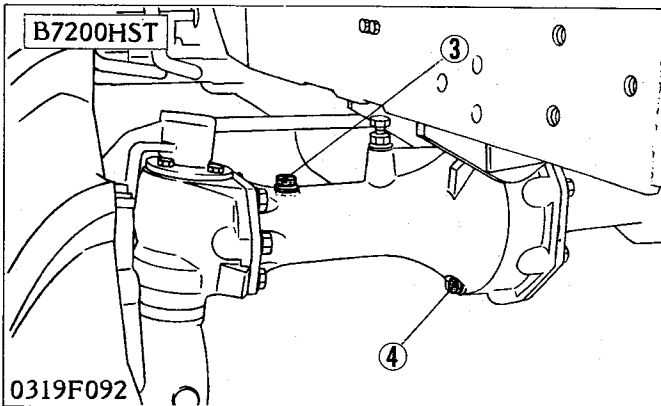
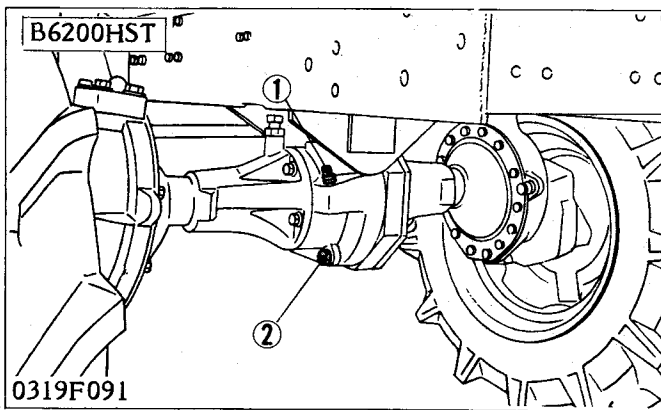
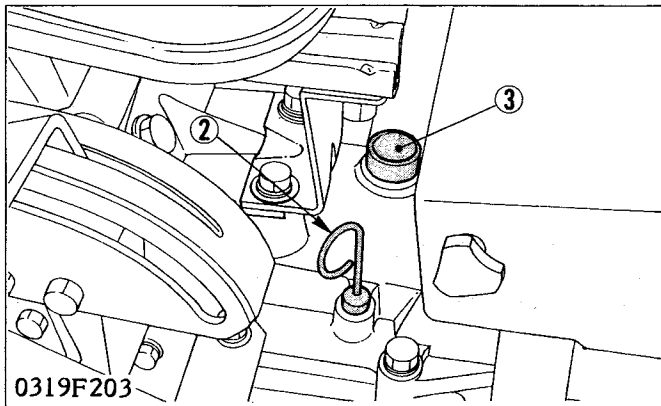
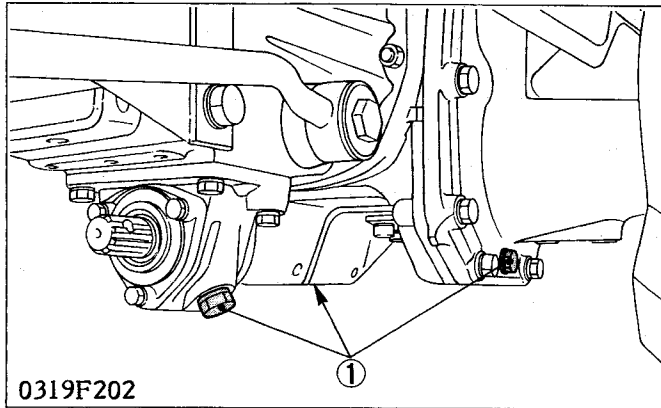

**Changing Transmission Oil**

1. See page S.G-7.

- (1) Drain Plug
- (2) Dipstick
- (3) Oil Port Plug

**Changing Front Axle Case Oil (B6200 HST 4WD) and Front Axle Arm Oil (B7200 HST 4WD)**

1. Remove the drain plug (2) from the front axle case to drain oil. (B6200 HST 4WD)
2. Remove the drain plug (4) from the front axle arm to drain oil. (B7200 HST 4WD)
3. Screw in the drain plug.
4. Fill new oil up to the specified level. Refer to "LUBRICANTS". (See page S.G-3)

**NOTE**

- Remove the filling port plug (1) or (3) to drain oil completely.

- (1) Filling Port Plug
- (2) Drain Plug
- (3) Filling Port Plug
- (4) Drain Plug

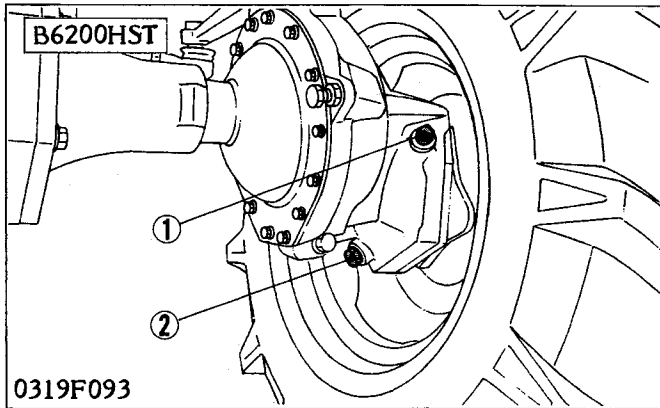

### Changing Gear Case Oil (B6200 HST 4WD) and Front Axle Case Oil (B7200 HST 4WD)

1. Remove the drain plug (2) from the gear case to drain oil. (B6200 HST 4WD)
2. Remove the drain plug (4) from the front axle case to drain oil. (B7200 HST 4WD)
3. Screw in the drain plug.
4. Fill new oil up to the specified level. Refer to "LUBRICANTS". (See page S.G-3)

#### ■ NOTE

- Remove the filling port plug (1) or (3) to drain oil completely.

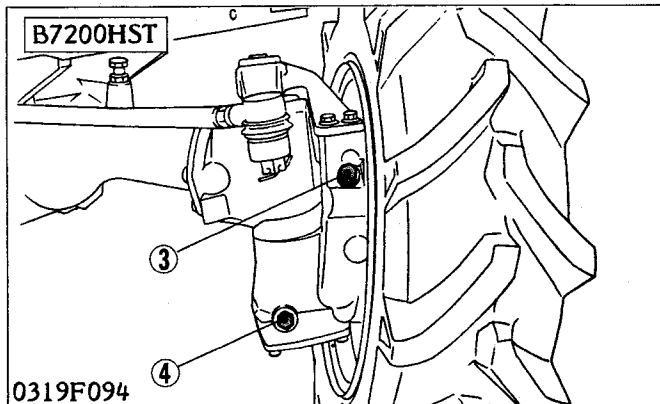

- (1) Filling Port Plug
- (2) Drain Plug
- (3) Filling Port Plug
- (4) Drain Plug

### (8) Check Points of Every 400 Hours

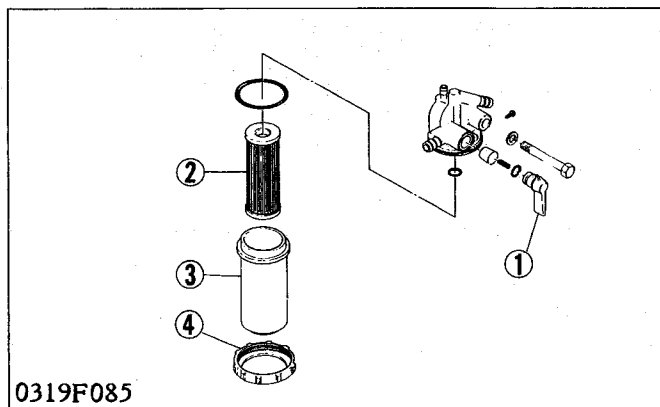

### Replacing Fuel Filter

1. Close the fuel filter cock (1).
2. Unscrew the screw ring (4) and remove the filter bowl (3).
3. Take out the element (2) and replace it with new one.

#### ■ IMPORTANT

- Use only genuine fuel filters.

- (1) Fuel Filter Cock
- (2) Element
- (3) Filter Bowl
- (4) Screw Ring

### (9) Check Points of Every 500 Hours

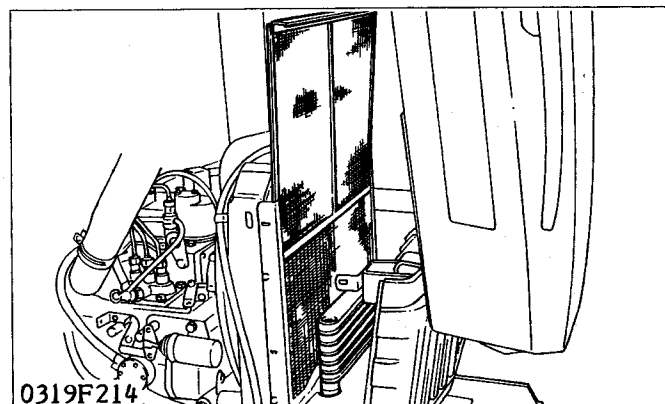

### Cleaning Cooling System

1. The engine cooling system should be cleaned on the following occasions:
  - Every 500 service hours.
  - When adding an anti-freeze solution.
  - When changing from water containing anti-freeze to pure water.
2. When cleaning the engine cooling system, the KUBOTA Scale Inhibitor No. 20 is recommended to effectively wash away the scale built-up.

(10) Check Points of Every One to Two Months

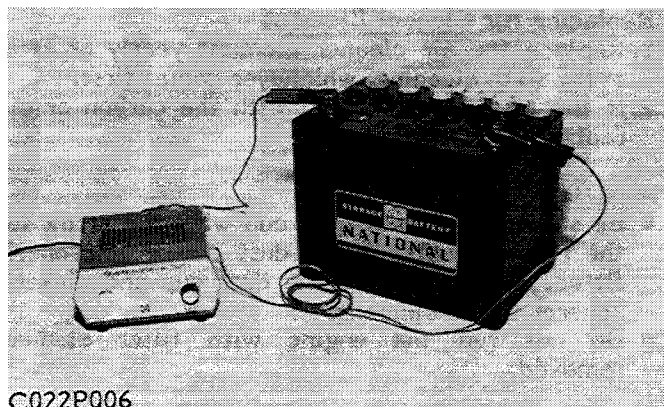

**Charging Battery**

1. If the battery is weak, the engine is difficult to start and the lamps become dim. It is important to check the battery and recharge before trouble occurs.
2. The water in the electrolyte evaporates during recharging. Liquid shortage damages the battery and excessive liquid spills over and damages the tractor body. If low, be sure to fill up the battery with distilled water.
3. To slow charge the battery connect the battery positive terminal to the charger positive terminal and the negative to the negative, then recharge in the standard fashion.
4. A boost charge is only for emergencies. It partially charges the battery at a high rate and in a short time. When using a boost-charged battery, it is necessary to recharge the battery as early as possible after the operation has been finished. Failure to do this extremely affects the service life due to overdischarge.

(11) Check Points of Every 3 Months

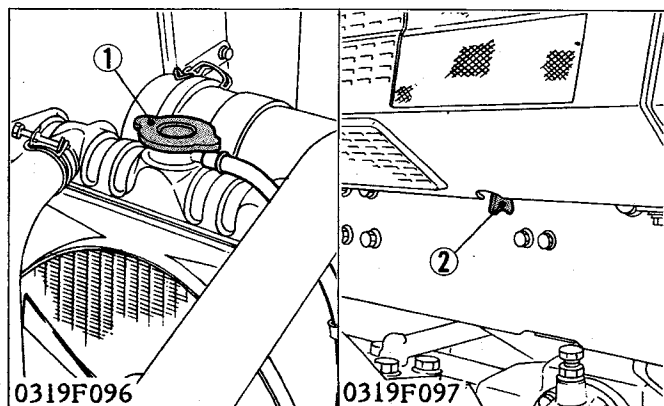

**Changing Scale Inhibitor and Coolant**

1. To drain the used coolant, remove the drain plug (2) and radiator cap (1).
2. Clean the radiator interior, and screw in the drain plug.
3. Fill clean and fresh water up to the specified level.

**IMPORTANT**

- After changing coolant, securely tighten the radiator cap.

- (1) Radiator Cap
- (2) Drain Plug

**(Reference)**

**KUBOTA Scale Inhibitor No.11**

- The KUBOTA Scale Inhibitor No. 11 prevents scale formation in the coolant. Scale which builds up in either hard or soft water sharply reduces cooling efficiency.
- The scale inhibitor is effective for 3 months, so a complete change of coolant must be done every 3 months.
- Do not use a scale inhibitor and an anti-freeze at the same time. This may cause sludge to form, adversely affecting the engine parts.

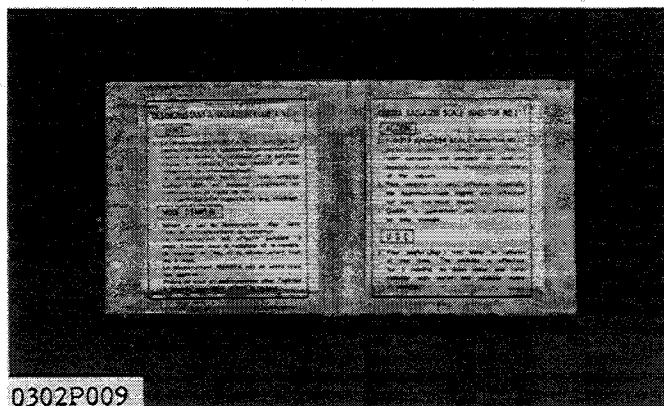

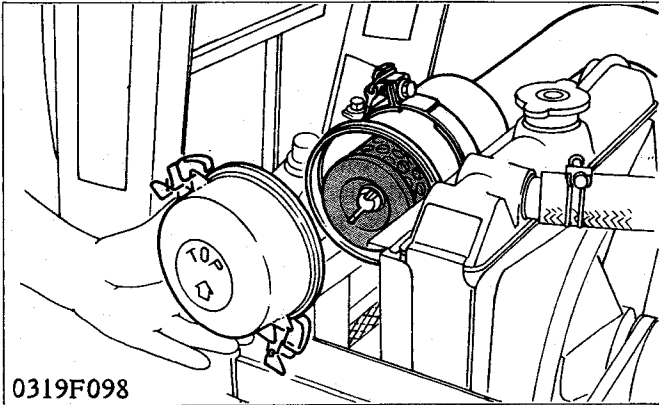
**(12) Check Points of Every Year or Every 6 Times of Cleaning****Replacing Air Cleaner Element**

1. Replace the air cleaner element yearly or after every sixth cleaning, whichever comes first.
2. If the element is stained with the carbon or oil, replace it.

**NOTE**

- Be sure to refit the dust cup with the arrow (on the rear) upright. If the dust cup is improperly fitted, dust passes by the dust cup and directly adheres to the element.
- Do not run the engine with filter element removed.

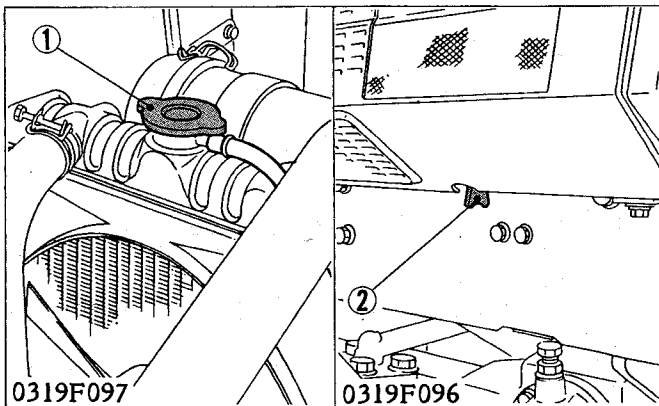
**(13) Check Points of Every Year****Changing Anti-freeze and Coolant**

1. To drain the used coolant, remove the drain plug (2) and radiator cap (1).
2. Clean the radiator interior, and screw in the drain plug.
3. Fill clean and fresh water up to the specified level.

**IMPORTANT**

- After changing coolant, securely tighten the radiator cap.

- (1) Radiator Cap  
(2) Drain Plug

**(Reference)****Anti-freeze**

- There are two types of antifreeze solutions, permanent type (PT) and semi-permanent type (SPT). For the engines, be sure to use the permanent type.
- Use a 50/50 mix of anti-freeze and water all year round.
- When antifreeze is used for the first time, fill and drain clean water twice or three times so as to completely clean the inside of the radiator.
- Radiator should be filled with antifreeze and water solution as recommended by the anti-freeze manufacturer.
- Mix the antifreeze and water, then pour the mixture into the radiator.
- When the coolant mixed with anti-freeze decreases due to evaporation, replenish with water only. If loss has been due to leaking, add water and anti-freeze mixture with the same mix ratio as the original preparation.
- Antifreeze absorbs moisture, so be sure to securely close the container after use.
- Antifreeze and water should be changed every year.
- Do not use an antifreeze and a scale inhibitor at the same time. This may cause sludge to form, adversely affecting the engine parts.



**(14) Check Points of Every 2 Years**

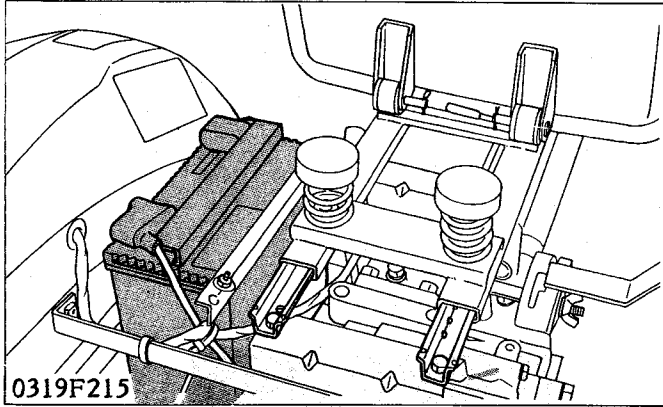

**Replacing Battery**

1. Check the battery.
2. If it is defective, replace with a new one (65 Ah equivalent).

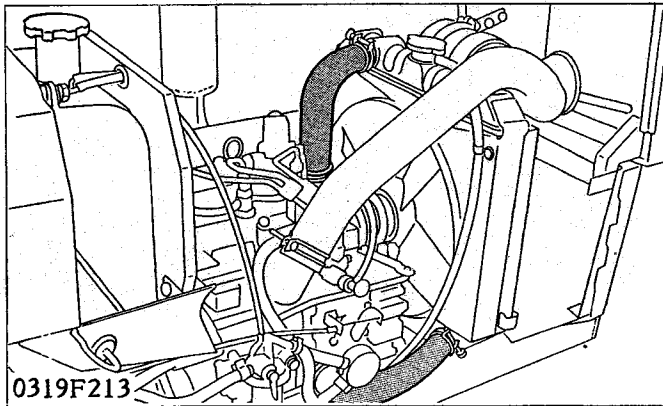

**Replacing Water Pipes and Clamps**

1. Replace the water pipes and clamps with a new one.

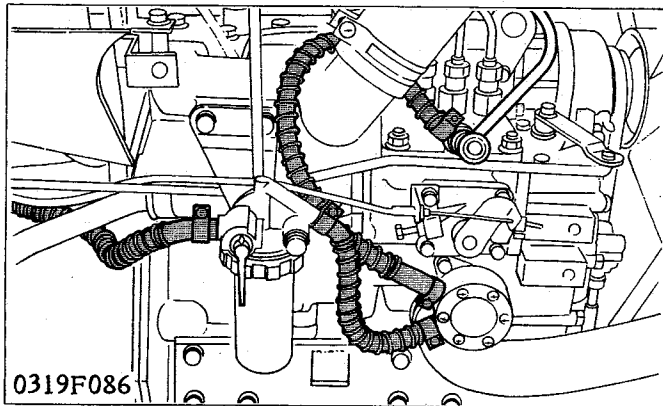

**Replacing Fuel Line and Clamps**

1. Replace the fuel line and clamps with a new one.

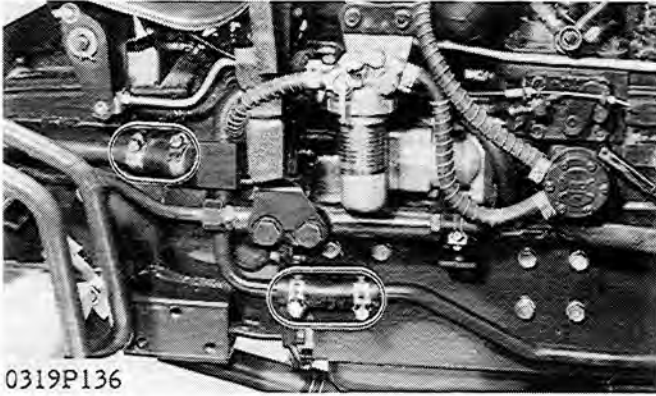

0319P136

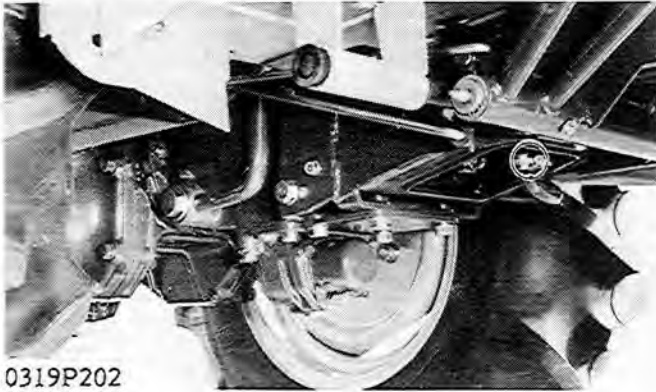

0319P202

### Replace Hydraulic Hose and Clamps

1. Replace the hydraulic hose and clamps with a new one.

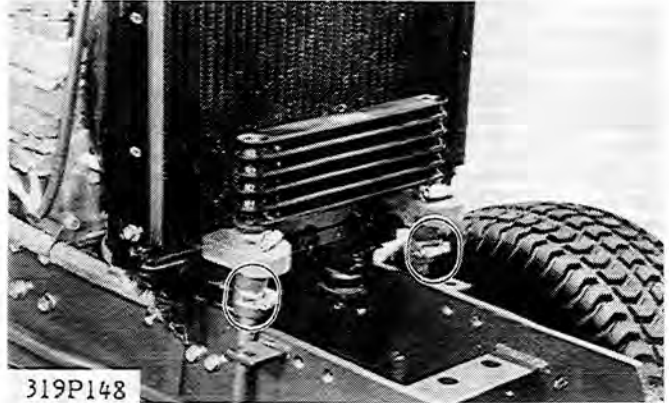

319P148

### **(15) Check Points of Every 800 Hours**

#### Checking Valve Clearance

- Refer to "KUBOTA Diesel Engine Workshop Manual D750-LA, D850-LA-1, D950-LA, D850-LA-H, D950-LA-H (Code No.07909-70121)".

Valve clearance

Factory specification..... 0.145 to 0.185 mm  
0.0057 to 0.0073 in.

**(16) Original Charge of Dry Type Battery**

1. Remove vent plugs and discard temporary sealing card-boards and tapes.
2. Fill each cell with electrolyte having a specific gravity given in Table 1 up to highest level marked on the battery case side.
3. After standing 2 or 3 hours, correct the electrolyte to the former level.
4. Connect the battery positive terminal with the positive terminal of the charging unit, and the battery negative terminal with the negative terminal of the charging unit.
5. Batteries are preferably charged by current showed in Table 2. Keep vent plugs removed during charging.
6. Check temperature of electrolyte, if it reaches 40 C (105 F) lower the charging rate. When the temperature is too high, reduce charging rate and charge for a proportionately longer period.
7. If the tractor is stored after original charge, periodically recharge as shown in Table 3. A battery is fully charged when the cells are all gassing freely and the specific gravity ceases to rise for three consecutive readings taken at hour intervals. Specific gravity should be adjusted to that shown in Table 1.
8. Check electrolyte level two hours after charging is finished and correct it if necessary by adding distilled water.

**⚠ CAUTION**

- After the battery is activated, hydrogen and oxygen gases in the battery are very explosive. Keep open sparks and flames away from the battery at all times, especially when charging the battery.
- Keep electrolyte away from eyes, hands and clothes. If you are spattered with it, wash it away completely with water.

Table 1

	AIR TEMPERATURES	
	TEMPERATE Ordinarily below 20°C (68°F)	TROPICAL Frequently above 20°C (68°F)
sp. gr. of electrolyte for filling	1.260	1.240
sp.gr. of electrolyte when fully charged	1.260 to 1.275	1.240 to 1.255

Table 2

TYPE	Volts (V)	Number of plate per cell	Capacity at 20 H.R (A.h)	Volume of Electrolyte (ℓ)	Normal Charging Rate (A)
NT80	12	13	45	2.8	4.5

Table 3

Period of storage from manufactured (months)	Freshing charge (times)
0 to 6	about 3 to 5 hours
6 to 12	10
over 12	30

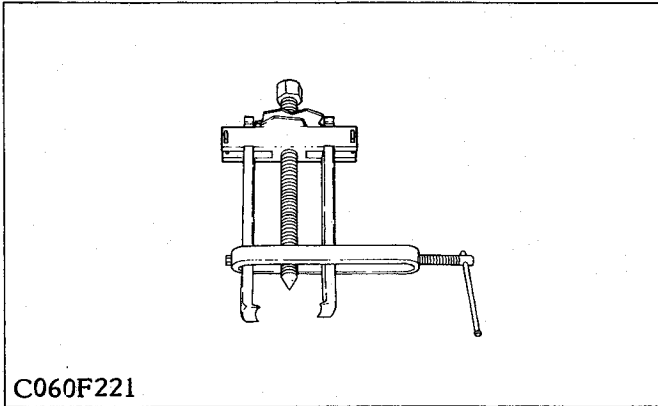
**[7] SPECIAL TOOLS****Special-use Puller Set**

Code No. : 07916-09032

Application : Use exclusively for pulling out bearings, gears and other parts with ease.

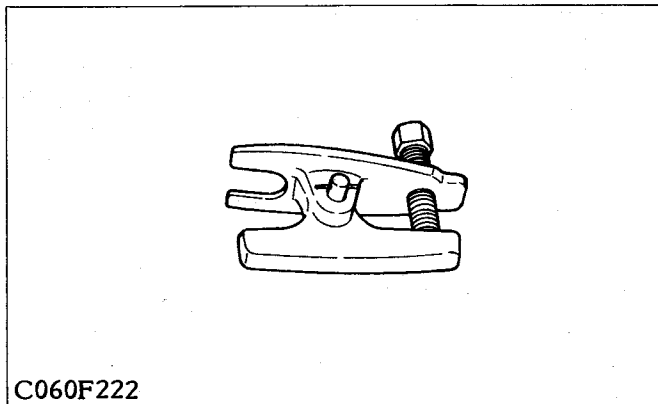
**Pitman Arm Puller**

Code No. : 07909-39011

Application : Use for pulling out pitman arm from tractor.

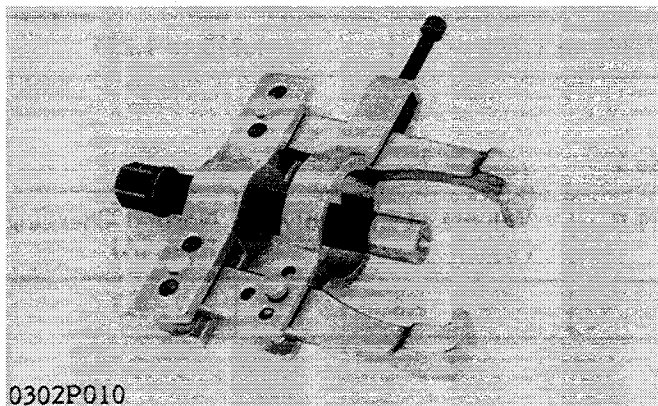
**Tie Rod End Lifter**

Code No. : 07909-39021

Application : This allows easy removal of tie rod end from tractor.

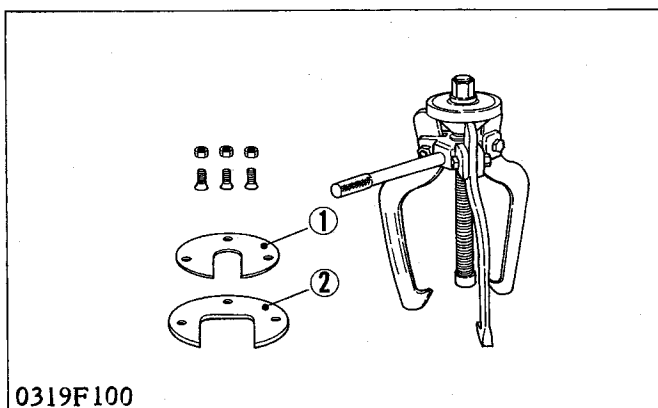
**Steering Wheel Puller**

Code No. : 07916-51090

Application : This allows easy removal of steering wheel without damaging steering shaft.

For B and L series tractors, set wheel support I (1) or wheel support II (2).

- (1) Wheel Support I
- (2) Wheel Support II

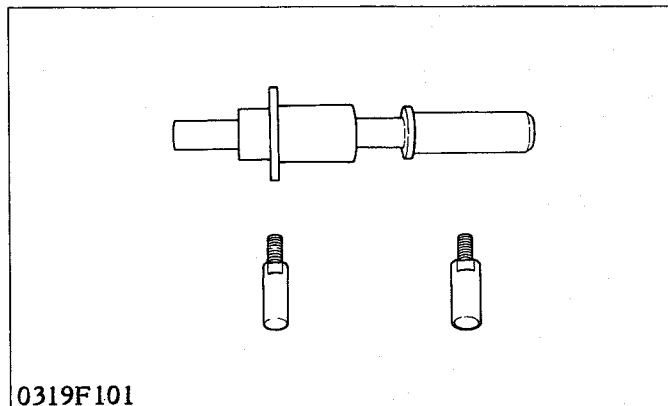
**Clutch Center Tool (For B Series Tractor)**

Code No. : 07906-50032

Application : Use to fit clutch to flywheel and also to check and adjust release lever height.

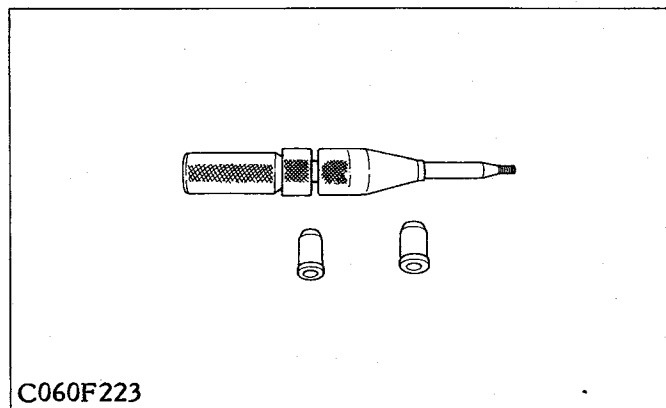
**Clutch Center Tool (For B and L Series Tractors)**

Code No. : 07916-51050

Application : The clutch center tool can be used for all B and L series tractors with a diaphragm clutch by changing tip guides.

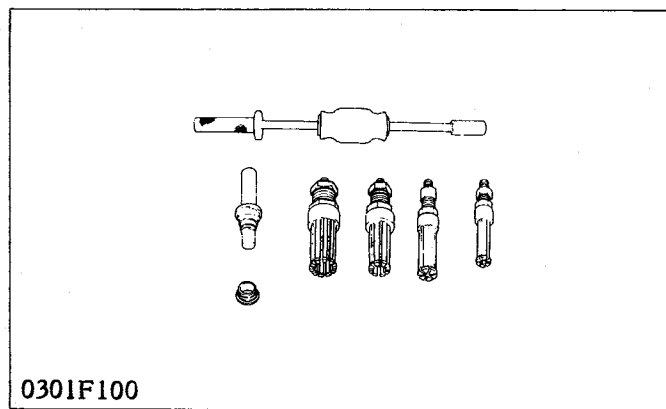
**Bushing Puller Set**

Code No. : 07916-51031

Application : Use for pulling out the front axle support bushing from the front axle.

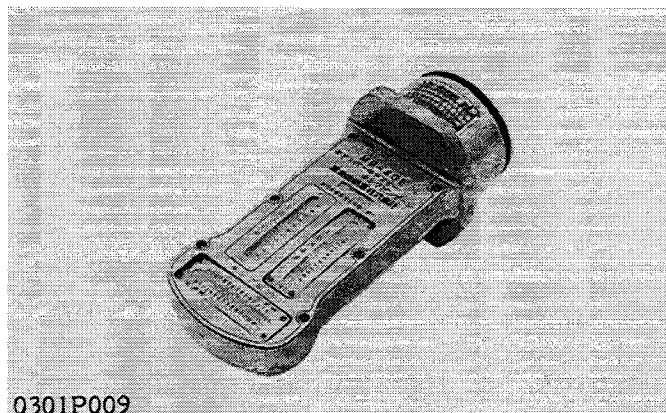
**Camber, Caster and King Pin Gauge**

Code No. : 07909-31691

Application : This allows easy measurement of camber angle, caster angle and king pin inclination for all tractor models.

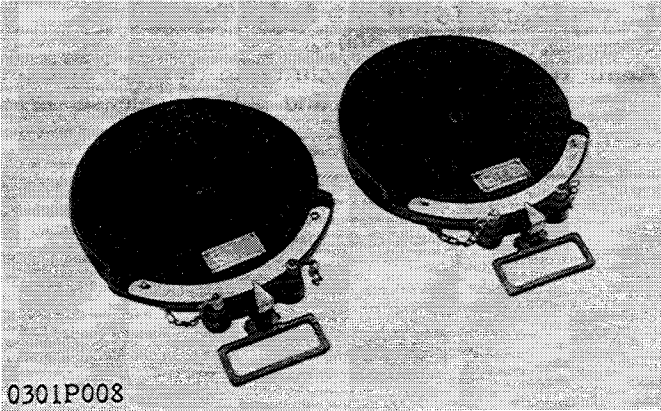
**Turning Radius Gauge**

Code No. : 07909-31701

Application : This allows easy measurement of steering angle for all tractor models.

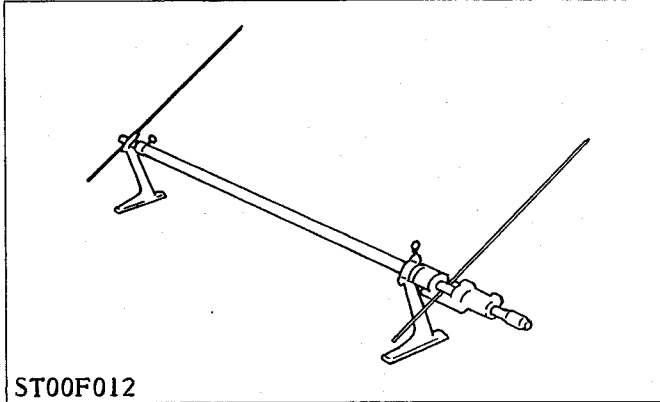
**Toe-in Gauge**

Code No. : 07909-31681

Application : This allows easy measurement of toe-in for all tractor models.

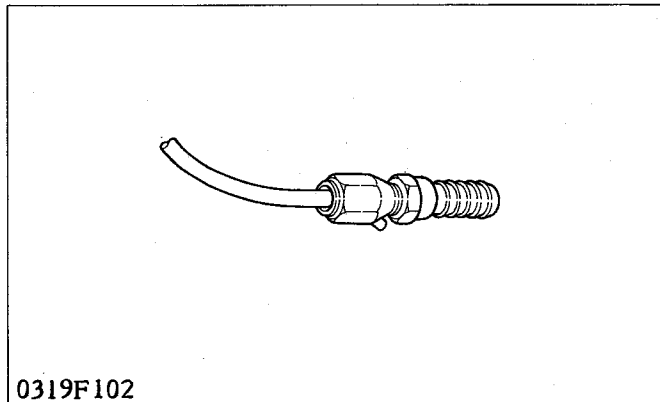
**Injector**

Code No. : 07916-52501

Application : If more traction is required, liquid (water) can be injected into the tires in addition to the weights.

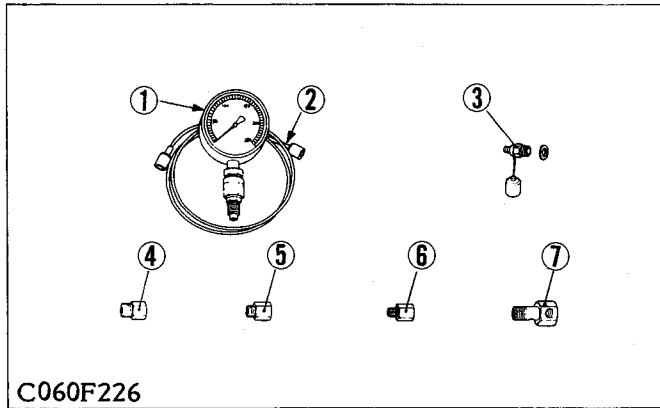

**Relief Valve Set Pressure Tester**

Code No. : 07916-50044

Application : This allows easy measurement of relief set pressure for all tractor models.

- (1) Pressure Gauge..... 07916-50321
- (2) Cable..... 07916-50331
- (3) Connector 4..... 07916-50401
- (4) Connector 3..... 07916-50341
- (5) Adaptor B (M18, P1.5)..... 07916-50361
- (6) Adaptor C (PS 3/8)..... 07916-50371
- (7) Adaptor D (PT 1/8)..... 07916-50381
- (8) Adaptor E (PS 3/8)..... 07916-50392

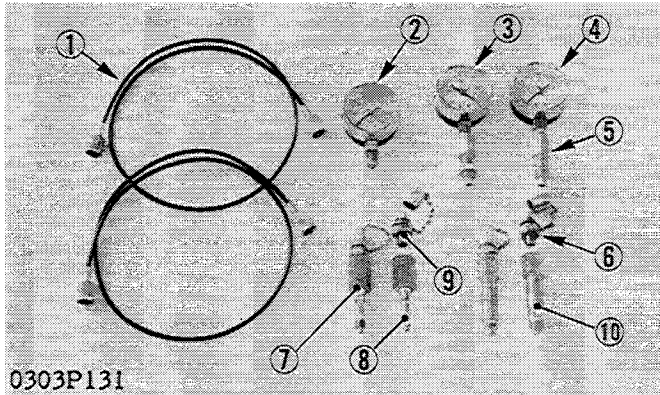

**Hydrostatic Transmission Testing Kit**

Code No. : 07916-52040

Application : This allows easy measurement of hydrostatic transmission pressure for B6200-B7200 HST tractor.

- (1) Cable..... 07916-50331
- (2) Pressure Gauge..... 07916-51301  
(Low pressure)
- (3) Vacuum Gauge..... 07916-51331
- (4) Pressure Gauge..... 07916-50322  
(High pressure)
- (5) Threaded Joint in Relief..... 07916-50401  
Valve Set Pressure Tester
- (6) Gasket..... 04714-00200
- (7) Connector 1..... 07916-60811
- (8) Connector 2..... 07916-60821
- (9) Threaded Joint..... 07916-50341
- (10) Long Connector..... 07916-60831

# S.S SEPARATION

TIGHTENING TORQUES.....	S.S-1
DISASSEMBLY AND ASSEMBLY.....	S.S-2
[1] DRAINING COOLING WATER AND OIL...	S.S-2
[2] SEPARATING FRONT AXLE ASSEMBLY..	S.S-4
[3] SEPARATING ENGINE.....	S.S-6
[4] SEPARATING CLUTCH HOUSING.....	S.S-8
[5] SEPARATING HYDRAULIC CYLINDER..	S.S-10
[6] SEPARATING TRANSMISSION CASE.....	S.S-11
[7] SEPARATING REAR AXLE CASE.....	S.S-12



# TIGHTENING TORQUES

Screws and Nuts	Tightening Torque		
	N-m	kgf-m	ft-lbs
Slotted nut	17.7 to 34.3	1.8 to 3.5	13.0 to 25.3
Front axle frame mounting screw	39.2 to 64.7	4.0 to 6.6	28.9 to 47.7
Engine mounting screw	23.5 to 27.5	2.4 to 2.8	17.4 to 20.3
Steering wheel mounting nut	41.2 to 58.8	4.2 to 6.0	30.4 to 43.4
Steering gear box mounting nut	39.2 to 64.7	4.0 to 6.6	28.9 to 47.7
Rear wheel hub cotter 2 and nut	166.7 to 191.2	17.0 to 19.5	123.0 to 141.0
Clutch housing mounting nut	41.2 to 58.8	4.2 to 6.0	30.4 to 43.4
HST mounting screw	48 to 56	4.9 to 5.7	35.4 to 41.2
Control valve mounting screw	16.7 to 21.6	1.7 to 2.2	12.3 to 15.9
Top link bracket mounting screw	39.2 to 64.7	4.0 to 6.6	28.9 to 47.7
Hydraulic cylinder mounting screw	20.6 to 29.4	2.1 to 3.0	15.2 to 21.7
Transmission case mounting nut	39.2 to 64.7	4.0 to 6.6	28.9 to 47.7
Rear axle case mounting screw			
M 10	39.2 to 64.7	4.0 to 6.6	28.9 to 47.7
M 12	60.8 to 106.9	6.2 to 10.9	44.8 to 78.8

# DISASSEMBLY AND ASSEMBLY

## [1] DRAINING COOLING WATER AND OIL

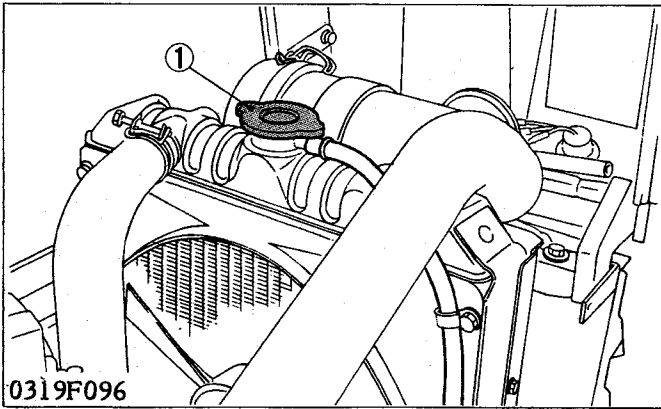

(1) Radiator Cap

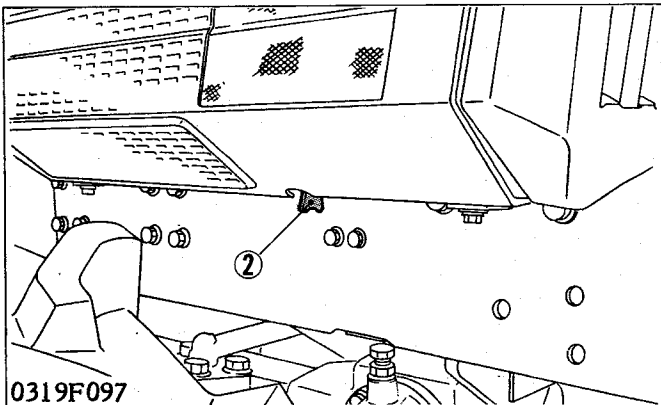

(2) Drain Plug

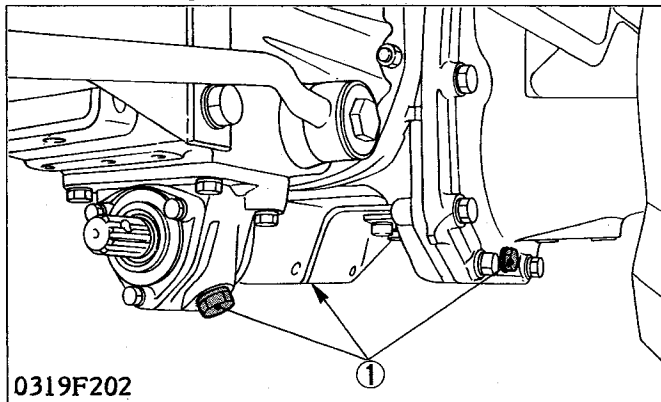

(1) Drain Plug

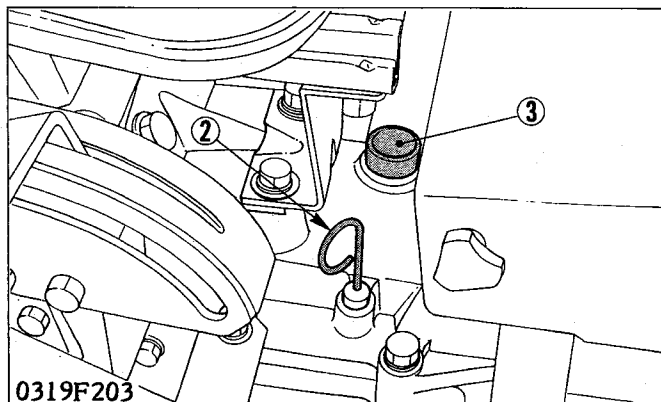

(2) Dipstick

(3) Oil Port

### Draining Cooling Water

**⚠ CAUTION**

- Never open the radiator cap while operating or immediately after stopping. Otherwise, hot water will spout out from the radiator. Wait for more than ten minutes to cool the radiator, before opening the cap.

1. Remove the drain plug (2) from the radiator to drain cooling water.

**(Capacity)**

B6200 HST (4WD)..... 2.8 ℓ (3.0 U.S.qts., 2.46 Imp.qts.)  
 B7200 HST (4WD)

**■ NOTE**

- Remove the radiator cap (1) to drain cooling water completely.

### Draining Transmission Oil

1. Remove the drain plug (1) to drain transmission oil.

**(Capacity)**

B6200 HST (4WD)..... 12 ℓ (13 U.S.qts., 10.6 Imp.qts.)  
 B7200 HST (4WD)

**(Lubricants)**

Manufacturer	Brand (Standard)
KUBOTA.....	UDT hydrostatic transmission fluid
SHELL.....	DONAX-TD, DONAX-TM
Mobil.....	Mobil Fluid 350
Exxon.....	Torque Fluid 56

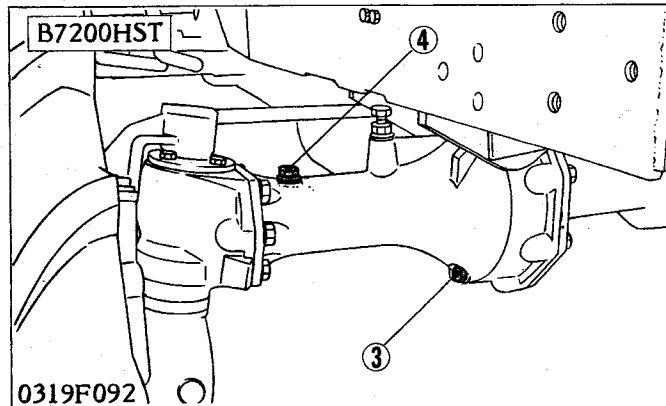
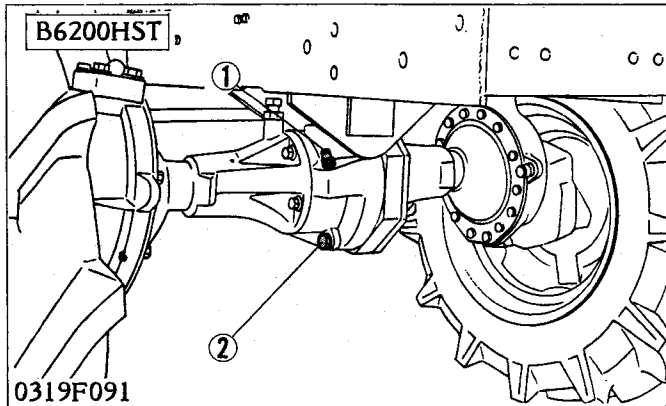

(1) Filling Port Plug (2) Drain Plug (3) Filling Port Plug (4) Drain Plug

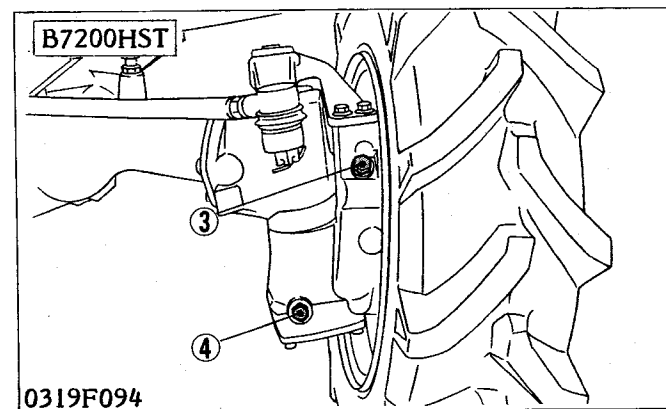
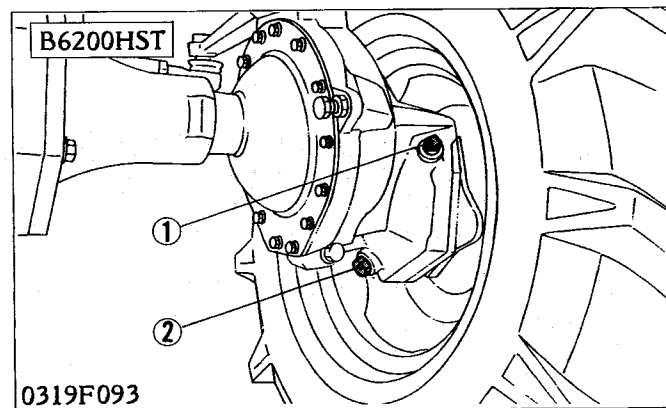

(1) Filling Port Plug (2) Drain Plug (3) Filling Port Plug (4) Drain Plug

**Changing Front Axle Case Oil (B6200 HST 4WD) and Front Axle Arm Oil (B7200 HST 4WD)**

1. Remove the drain plug (2) from the front axle case to drain oil. (B6200 HST 4WD)
2. Remove the drain plug (4) from the front axle arm to drain oil. (B7200 HST 4WD)

**(Capacity)**

Front axle case.....	0.5 ℓ (0.5 U.S.qts.,
(B6200 HST 4WD)	0.44 Imp.qts.)
Front axle arm.....	1.5 ℓ (1.6 U.S.qts.,
(B7200 HST 4WD)	1.32 Imp.qts.)

**(Lubricants)**

Gear oil SAE 80 or SAE 90

**NOTE**

- Remove the filling port plug (1) or (3) to drain oil completely.

**Changing Gear Case Oil (B6200 HST 4WD) and Front Axle Case Oil (B7200 HST 4WD)**

1. Remove the drain plug (2) from the gear case to drain oil. (B6200 HST 4WD)
2. Remove the drain plug (4) from the front axle case to drain oil. (B7200 HST 4WD)

**(Capacity)**

Gear case.....	0.15 ℓ (0.16 U.S.qts.,
(B6200 HST 4WD)	0.13 Imp.qts.)
Front axle case.....	0.5 ℓ (0.5 U.S.qts.,
(B7200 HST 4WD)	0.44 Imp.qts.)

**(Lubricants)**

Gear oil SAE 80 or SAE 90

**NOTE**

- Remove the filling port plug (1) or (3) to drain oil completely.

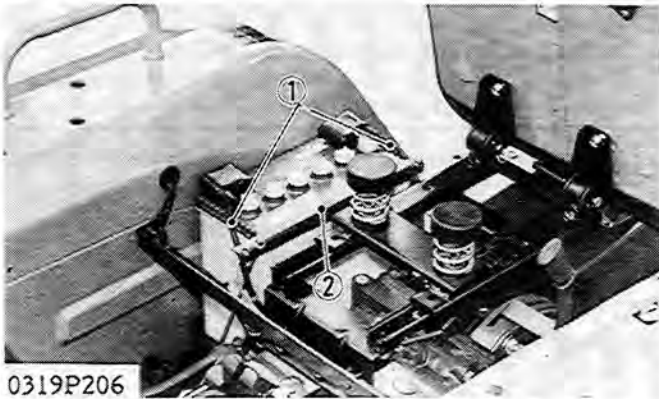
**[2] SEPARATING FRONT AXLE ASSEMBLY**

0319P206

(1) Battery Cord (2) Battery Retainer

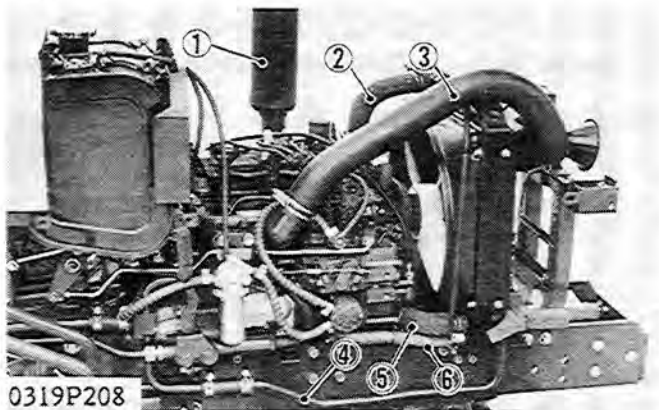

0319P207

(1) Hood (4) Clevis Pin  
(2) Right Skirt (5) Left Skirt  
(3) Front Skirt

0319P208

(1) Muffler (4) Suction Pipe 2  
(2) Water Pipe 4 (5) Water Pipe 1  
(3) Inlet Pipe (6) Drain Pipe**Battery**

1. Remove the battery cords (1).
2. Remove the battery retainer (2), and remove the battery.

**NOTE**

- When disconnecting the battery cords, disconnect the grounding cord first. When connecting, connect the positive cord first.

**Hood and Skirts**

1. Remove the front skirt (3).
2. Remove the right and left skirts (2), (5) with the auxiliary skirt.
3. Remove the clevis pin (4), and remove the hood (1).

**Water Pipes, Inlet Pipe, Suction Pipe 2 and Muffler**

1. Loosen the clamps and disconnect water pipe 1 (5), water pipe 4 (2) and the drain pipe (6).
2. Loosen the clamps and then disconnect the inlet pipe (3).
3. Loosen the clamps and disconnect suction pipe 2 (4) from oil cooler.
4. Remove the muffler (1).

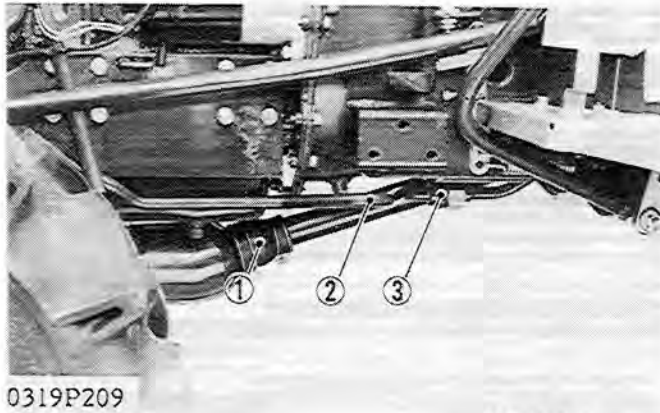

0319P209

(1) Pipe 3  
(2) Return Pipe 2  
(3) Joint

**Pipe 3 (4WD) and Return Pipe 2**

1. Loosen the clamps and slide pipe 3 (1) backward.
2. Disconnect the return pipe 2 (2) at the joint (3).

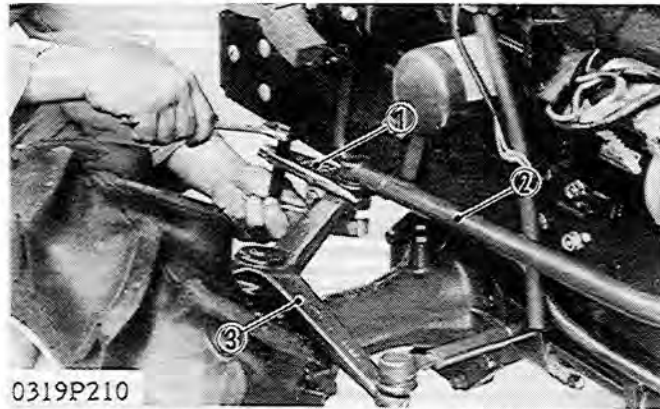

0319P210

(1) Tie Rod End Lifter  
(2) Drag Link  
(3) Knuckle Arm

**Drag Link**

1. Steer the front wheels to the left.
2. Remove the slotted nut connecting the knuckle arm (3) and drag link (2), and disconnect the drag link at the front end with a tie rod end lifter (1) (Code No: 07909-39021).

**■ IMPORTANT**

- After tightening the slotted nut to the specified torque, install the split pin as shown in the figure.

**(Tightening torque)**

Slotted nut.....	17.7 to 34.3 N-m
	1.8 to 3.5 kgf-m
	13.0 to 25.3 ft-lbs

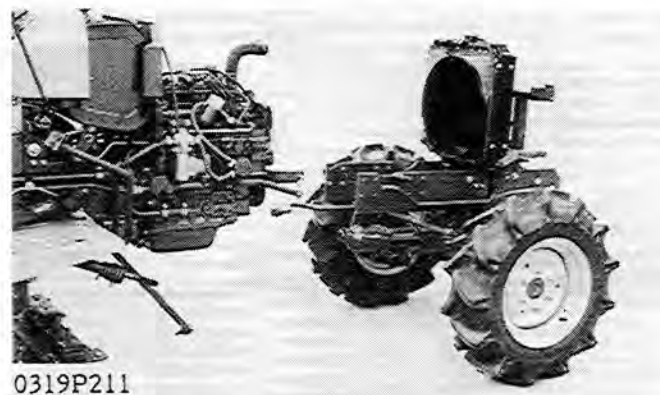

0319P211

**Separating Front Axle Assembly**

1. Remove the front axle frame mounting screws and separate the front axle assembly from the engine.

**(When reassembling)**

- Correctly align the drive shaft and universal joint spline (4WD type only).

**(Tightening torque)**

Front axle frame.....	39.2 to 64.7 N-m
mounting screw	4.0 to 6.6 kgf-m
	28.9 to 47.7 ft-lbs

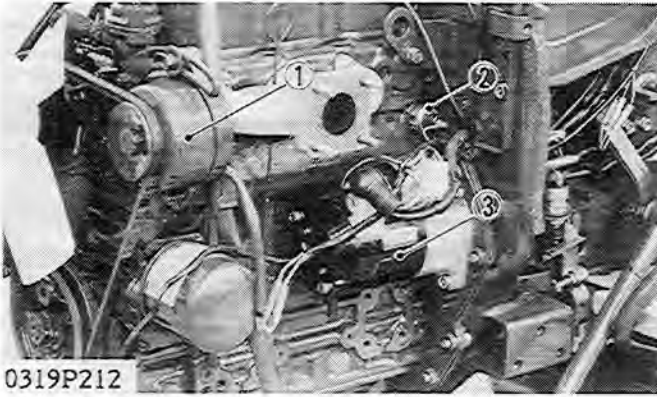
**[3] SEPARATING ENGINE**

0319P212

- (1) Dynamo  
 (2) Oil Switch  
 (3) Starter

**Starter and Wiring**

1. Disconnect the wiring for the dynamo (1).
2. Disconnect the wiring for the oil switch (2).
3. Disconnect the wiring for the starter (3), and remove the starter from the engine.

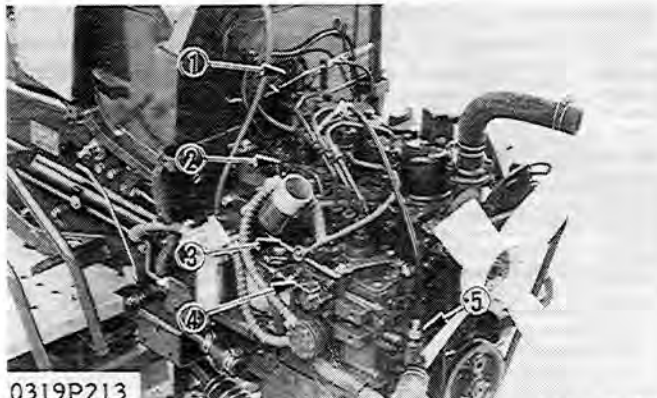

0319P213

- (1) Decompression Wire  
 (2) Wiring  
 (3) Accelerator Control Rod  
 (4) Engine Stop Wire  
 (5) Hourmeter Cable

**Rod, Wires, Cable and Wiring**

1. Remove the accelerator control rod (3) from the speed change lever.
2. Disconnect the engine stop wire (4) from the stop lever.
3. Remove the decompression wire (1) from the decompression lever.
4. Disconnect the hourmeter cable (5).
5. Disconnect the wiring (2) for the glow plug.

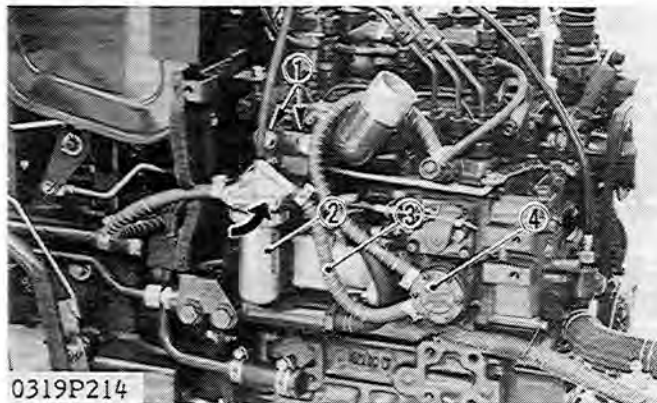

0319P214

- (1) Screw  
 (2) Fuel Filter  
 (3) Fuel Pipe  
 (4) Fuel Pump

**Fuel Pipe**

1. Close the filter cock.
2. Disconnect the fuel pipe (3) between the fuel pump (4) and the fuel filter (2) at the fuel filter side.
3. Remove the filter mounting screws (1), and remove the fuel filter from the engine.

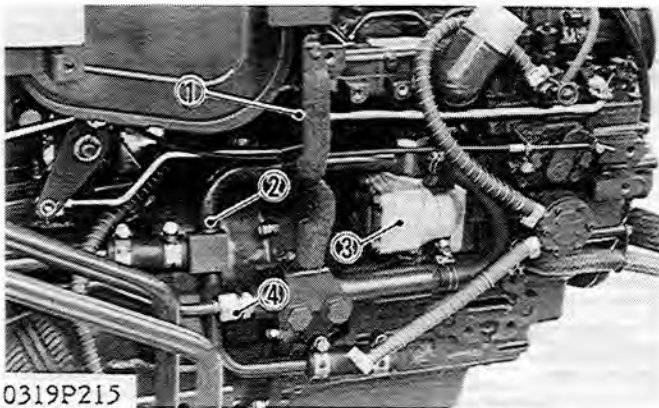

0319P215

- (1) Shutter Plate
- (2) Suction Pipe 1
- (3) Hydraulic Pump
- (4) Delivery Pipe Joint Nut

**Suction Pipe 1, Delivery Pipe and Shutter Plate**

1. Disconnect the suction pipe 1 (2) from the hydraulic pump (3).
2. Remove the delivery pipe joint nut (4).
3. Remove the shutter plate (1).

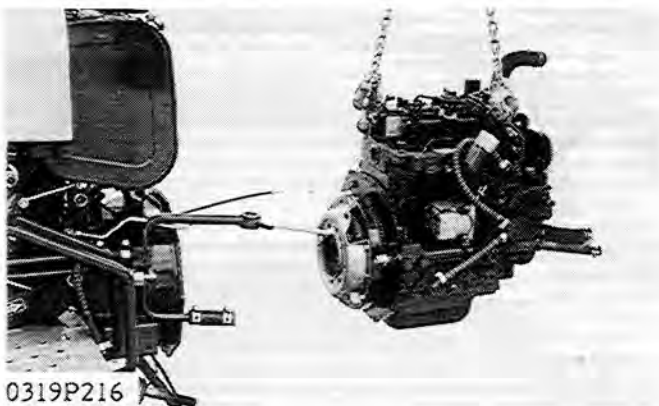

0319P216

**Separating Engine**

1. Remove the mounting screws, and separate the engine from the clutch housing.

**(When reassembling)**

- Be sure to replace the gasket on the clutch housing with a new one.

**(Tightening torque)**

Engine mounting.....	23.5 to 27.5 N-m
screw	2.4 to 2.8 kgf-m
	17.4 to 20.2 ft-lbs

**[4] SEPARATING CLUTCH HOUSING**



0319P217

- (1) Steering Wheel Puller

**Steering Wheel**

1. Remove the steering wheel cap.
2. Remove the steering wheel mounting nut, and remove the wheel with a steering wheel puller (1) (Code No: 07916-51090).

**(Tightening torque)**

Steering wheel.....	41.2 to 58.8 N-m
mounting nut	4.2 to 6.0 kgf-m
	30.4 to 43.4 ft-lbs

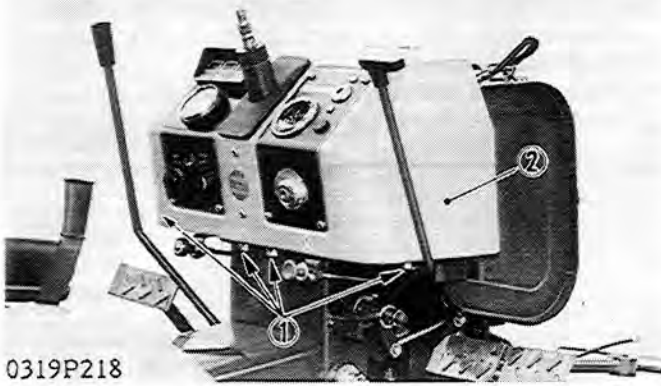

0319P218

(1) Screw

(2) Meter Panel

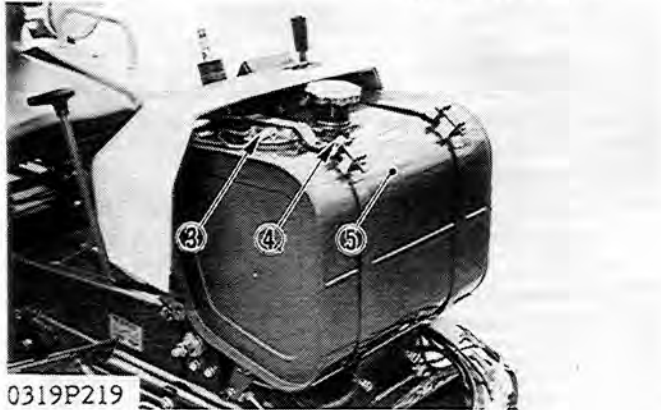

0319P219

(3) Fuel Unit  
(4) Screw

(5) Fuel Tank

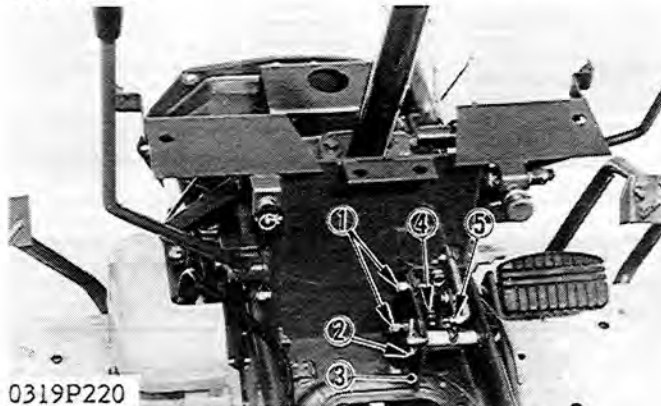

0319P220

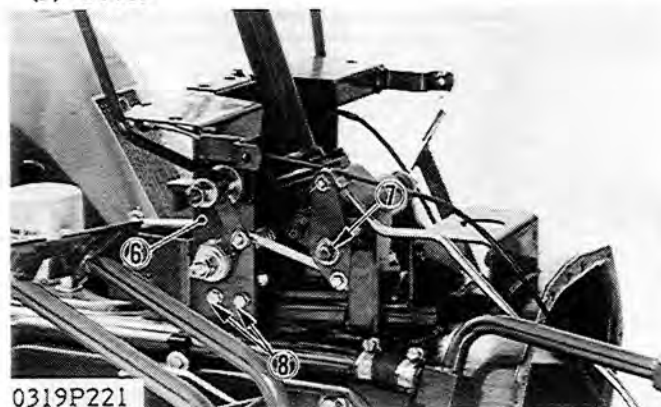
(1) Screw  
(2) Cotter Pin  
(3) Cover(4) Screw  
(5) Cotter Pin

0319P221

(6) Meter Panel Holder  
(7) Cotter Pin

(8) Screw

**Meter Panel and Fuel Tank**

1. Disconnect the wire harness and the wiring for the fuel unit (3).
2. Remove the meter panel mounting screws (1), and remove the meter panel (2).
3. Remove the fuel tank band mounting screws (4) and remove the fuel tank (5).
4. Remove the fuel tank support.

**Meter Panel Holder**

1. Remove the cotter pin (2) and screws (1), and remove the cover (3).
2. Remove the cotter pin (5) and the rod.
3. Remove the screw (4) and the cotter pin (7), and remove the rod.
4. Remove the meter panel holder screws (8) and remove the meter panel holder (6).



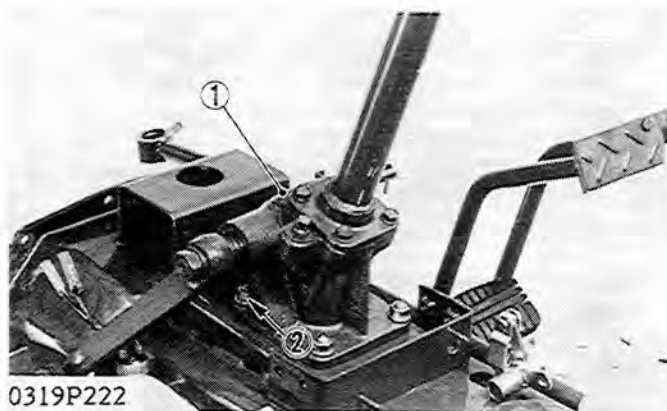

0319P222

(1) Steering Assembly

(2) Nut

**Steering Assembly**

1. Remove the slotted nut, and disconnect the drag link with a tie rod end lifter.
2. Remove the steering gear box mounting nuts, (2) and remove the steering assembly (1) from the clutch housing.

**(Tightening torque)**

Steering gear box.....	39.2 to 64.7 N-m
mounting nut	4.0 to 6.6 kgf-m
	28.9 to 47.7 ft-lbs
Slotted nut.....	17.7 to 34.3 N-m
	1.8 to 3.5 kgf-m
	13.0 to 25.3 ft-lbs

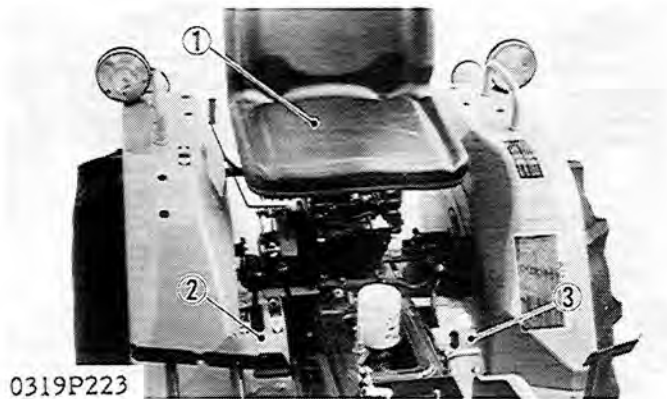

0319P223

(1) Seat

(2) Cover (RH)

(3) Cover (LH)

**Seat, Tires, Fenders and Covers**

1. Remove the seat (1).
2. Remove the left and right tires.
3. Remove the wiring (5).
4. Remove the left and right covers (3), (2).
5. Remove the right fender (4), and remove the left fender with battery bracket (6).

**(Tightening torque)**

Rear wheel hub.....	166.7 to 191.2 N-m
cotter 2 and nut	17.0 to 19.5 kgf-m
	123.0 to 141.0 ft-lbs



0319P224

(4) Fender (RH)

(5) Wiring

(6) Battery Bracket

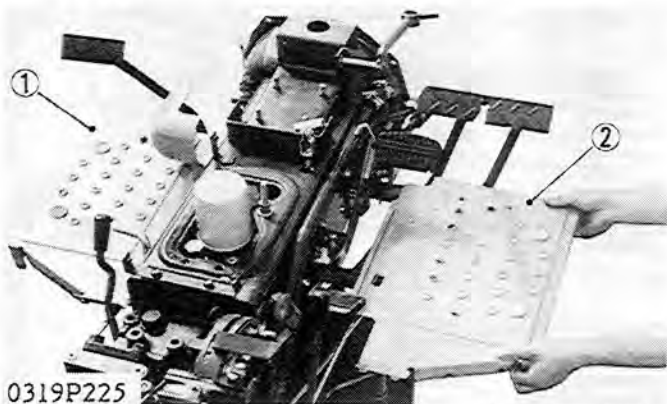

0319P225

(1) Step (LH)

(2) Step (RH)

**Steps**

- I. Remove the left and right steps (1), (2).

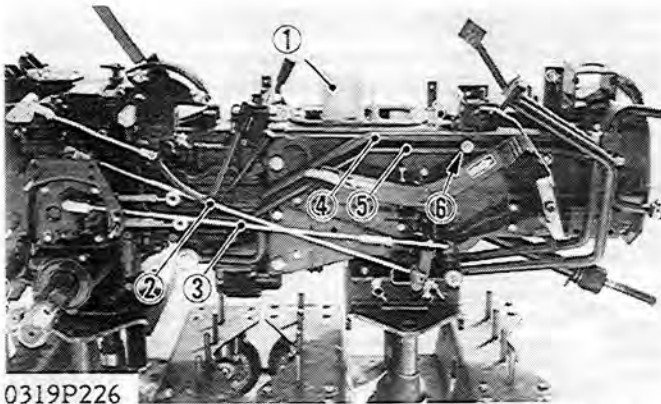

0319P226

- |                           |                   |
|---------------------------|-------------------|
| (1) Oil Filter            | (4) Inlet Pipe    |
| (2) Differential Lock Rod | (5) Delivery Pipe |
| (3) Brake Rod             | (6) Pipe Clamp    |



0319P227

- |                |         |
|----------------|---------|
| (7) Cotter Pin | (8) Rod |
|----------------|---------|



0319P228

- |                                   |              |
|-----------------------------------|--------------|
| (1) Filter Joint                  | (4) Lock Nut |
| (2) Eye Joint Bolt                | (5) Nut      |
| (3) Spring Tension Adjusting Bolt |              |

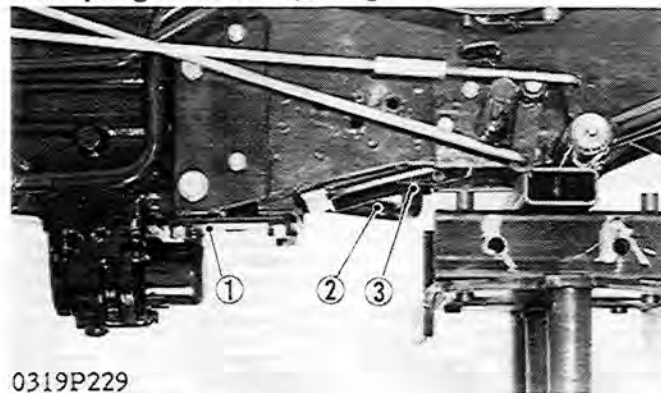

0319P229

- |                      |           |
|----------------------|-----------|
| (1) Connecting Plate | (3) Clamp |
| (2) Hydraulic Pipe   |           |

S.S-10

**Inlet Pipe, Delivery Pipe, Oil Filter and Rods**

1. Remove the pipe clamp (6), and remove the inlet pipe (4) and delivery pipe (5).
2. Remove the oil filter (1).
3. Remove the left and right brake rods (3).
4. Remove the differential lock rod (2).
5. Remove the cotter pin (7), and remove the rod (8).

**(When reassembling)**

- Use care not to damage the O-rings on the inlet pipe.
- If loosen the turnbuckle during disassembly, adjust the length of brake rod.  
(See page S.G-13)

**Filter Joint, Eye Joint Bolt and Spring Tension Adjusting Bolt**

1. Remove the filter joint (1), the eye joint bolt (2) and the hydraulic pipe.
2. Remove the lock nut (4), nut (5) and remove the spring and spring tension adjusting bolt (3).

**Hydraulic Pipe and Connecting Plate**

1. Loosen the hose clamp (3) and remove the hydraulic pipe (2).
2. Remove the connecting plate (1).

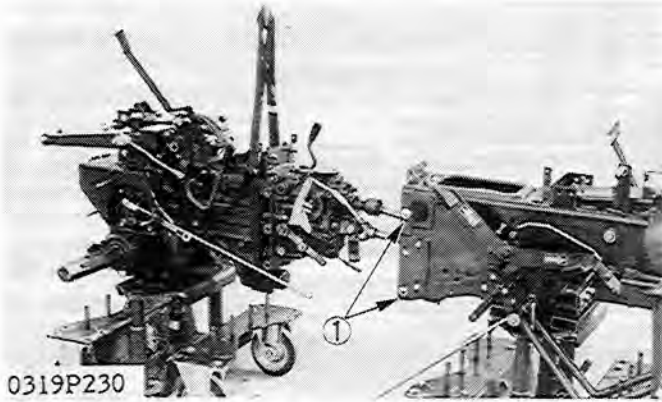

0319P230

(1) Reamer Bolt

**Separating Clutch Housing**

1. Remove the clutch housing mounting nuts, and separate the clutch housing.

**(When reassembling)**

- Replace the reamer bolts (1) at their original positions.

**(Tightening torque)**

Clutch housing.....	41.2 to 58.8 N-m
mounting nut	4.2 to 6.0 kgf-m
	30.4 to 43.4 ft-lbs

**[5] SEPARATING HYDROSTATIC TRANSMISSION**

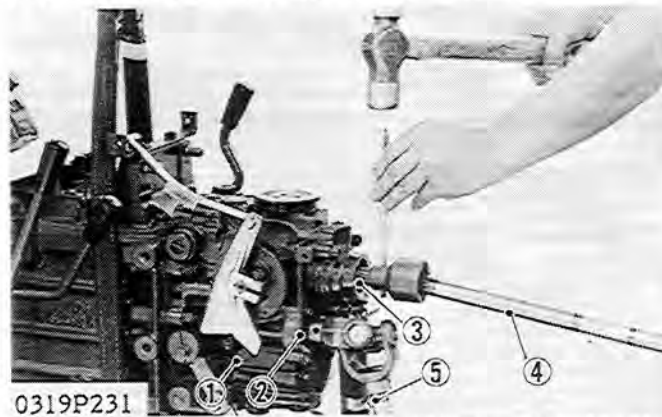

0319P231

(1) HST (4) Propeller Shaft  
(2) Front Wheel Drive Shaft (5) Drive Shaft  
(3) 1st Shaft

**Hydrostatic Transmission (HST)**

1. Remove the propeller shaft (4) from the 1st shaft (3).
2. Remove the drive shaft (5) from the front wheel drive shaft (2). (4WD type only)
3. Remove the HST mounting screws, and remove the HST (1).

**(When reassembling)**

- After inserting the spring pin to the 1st shaft and drive shaft, lock the spring pin with a wire.

**(Tightening torque)**

HST mounting screw.....	48 to 56 N-m
	4.9 to 5.7 kgf-m
	35.4 to 41.2 ft-lbs

**[6] SEPARATING HYDRAULIC CYLINDER**



0319P232

(1) Top Link Bracket (3) Control Valve  
(2) Feedback Rod

**Control Valve and Top Link Bracket**

1. Remove the control valve (3) with the feedback rod (2). (B6200-B7200 HST 4WD type)
2. Remove the control valve with the check rod. (2WD type)
3. Remove the top link bracket (3).

**(When reassembling)**

- Use care not to damage the O-rings on the control valve.

**(Tightening torque)**

Control valve mounting screw	16.7 to 21.6 N-m
(B6200-B7200 HST 4WD type)..	1.7 to 2.2 kgf-m
	12.3 to 15.9 ft-lbs
(2WD type).....	16.7 to 21.6 N-m
	1.7 to 2.2 kgf-m
	12.3 to 15.9 ft-lbs
Top link bracket.....	39.2 to 64.7 N-m
mounting screw	4.0 to 6.6 kgf-m
	28.9 to 47.7 ft-lbs

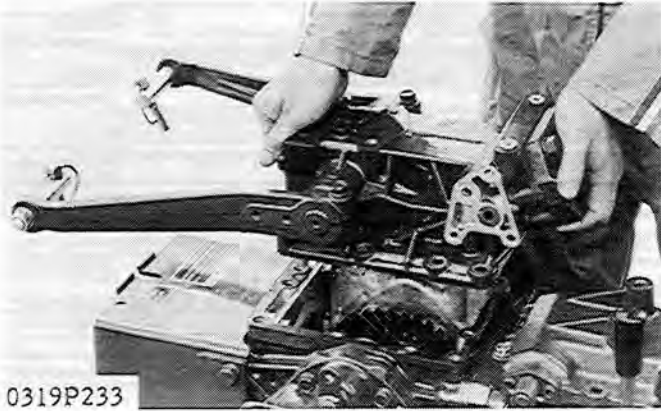
**Hydraulic Cylinder**

1. Remove the hydraulic cylinder mounting screws, and separate the hydraulic cylinder.

**(When reassembling)**

- Be sure to replace the gasket with a new one.

**(Tightening torque)**

Hydraulic cylinder.....	20.6 to 29.4 N-m
mounting screw	2.1 to 3.0 kgf-m
	15.2 to 21.7 ft-lbs

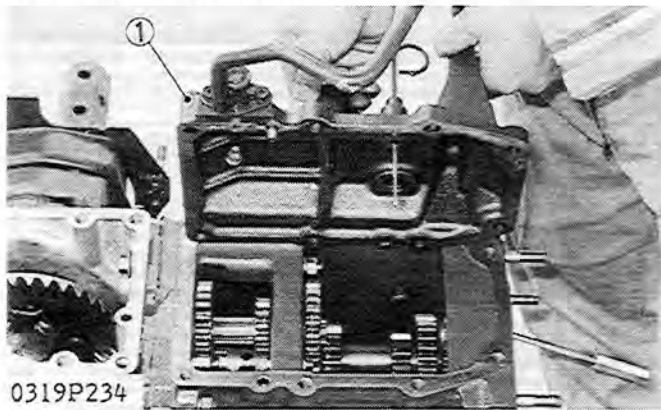
**[7] SEPARATING TRANSMISSION CASE**

(1) Front Case Cover

**Front Case Cover**

1. Set the main speed change lever in neutral position, and remove the front case cover (1).

**(When reassembling)**

- Apply liquid gasket (Three Bond 1102 or equivalent) to the both sides of new gasket.

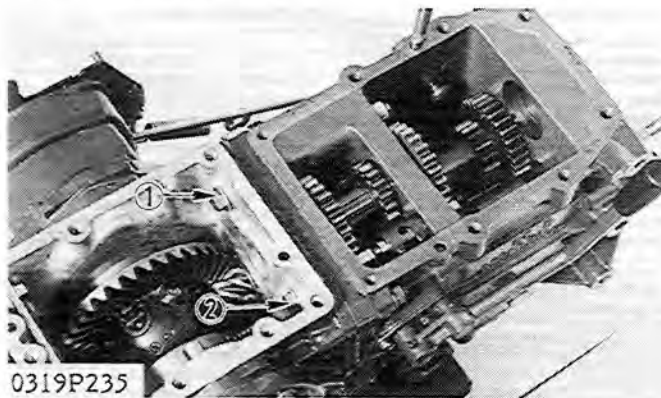

(1) Bolt

(2) Fork Shaft Lock Screw

**Separating Transmission Case**

1. Remove the bolt (1).
2. Remove the fork shaft lock screw (2).
3. Remove the transmission case mounting nuts, and separate the transmission case.

**(When reassembling)**

- Apply liquid gasket (Three Bond 1102 or equivalent) to both sides of new gasket.

**(Tightening torque)**

Transmission case.....	39.2 to 64.7 N-m
mounting nut	4.0 to 6.6 kgf-m
	28.9 to 47.7 ft-lbs

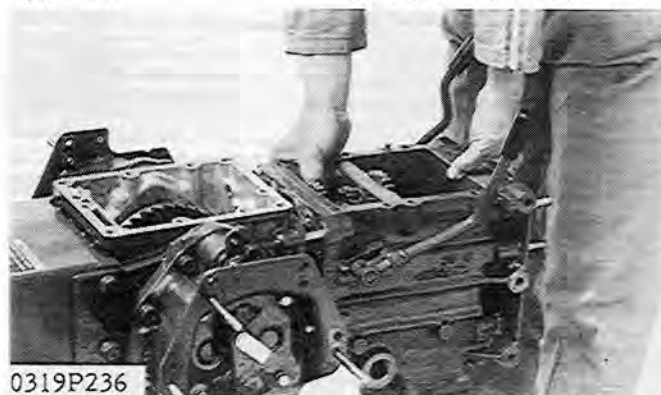

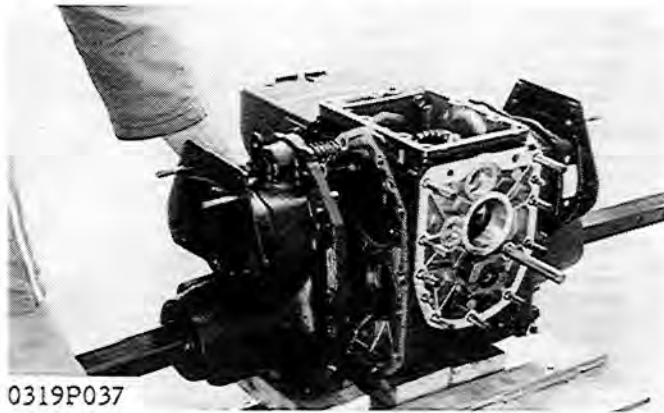
**[8] SEPARATING REAR AXLE CASE****Separating Rear Axle Case**

1. Remove the rear axle case mounting screws, and separate the rear axle case.

**(When reassembling)**

- Be sure to replace the gasket with a new one.

**(Tightening torque)**

Rear axle case mounting screw

M 10.....	39.2 to 64.7 N-m
	4.0 to 6.6 kgf-m
	28.9 to 47.7 ft-lbs
M 12.....	60.8 to 106.9 N-m
	6.2 to 10.9 kgf-m
	44.8 to 78.8 ft-lbs

# S.2 TRANSMISSION

TROUBLESHOOTING.....	S.2-1
SERVICING SPECIFICATIONS.....	S.2-4
TIGHTENING TORQUES.....	S.2-3
DISASSEMBLY AND SERVICING.....	S.2-9
[1] SPEED SET DEVICE	
Disassembly and Assembly.....	S.2-9
[2] HYDROSTATIC TRANSMISSION	
Checking and adjustment.....	S.2-10
Disassembly and Assembly.....	S.2-15
Servicing.....	S.2-21
[3] MECHANICAL TRANSMISSION	
Disassembly and Assembly.....	S.2-29
[4] DIFFERENTIAL GEAR CASE	
Disassembly and Assembly.....	S.2-32
[5] TRANSMISSION (TRANSMISSION CASE, DIFFERENTIAL GEAR CASE)	
Servicing.....	S.2-33

# TROUBLESHOOTING

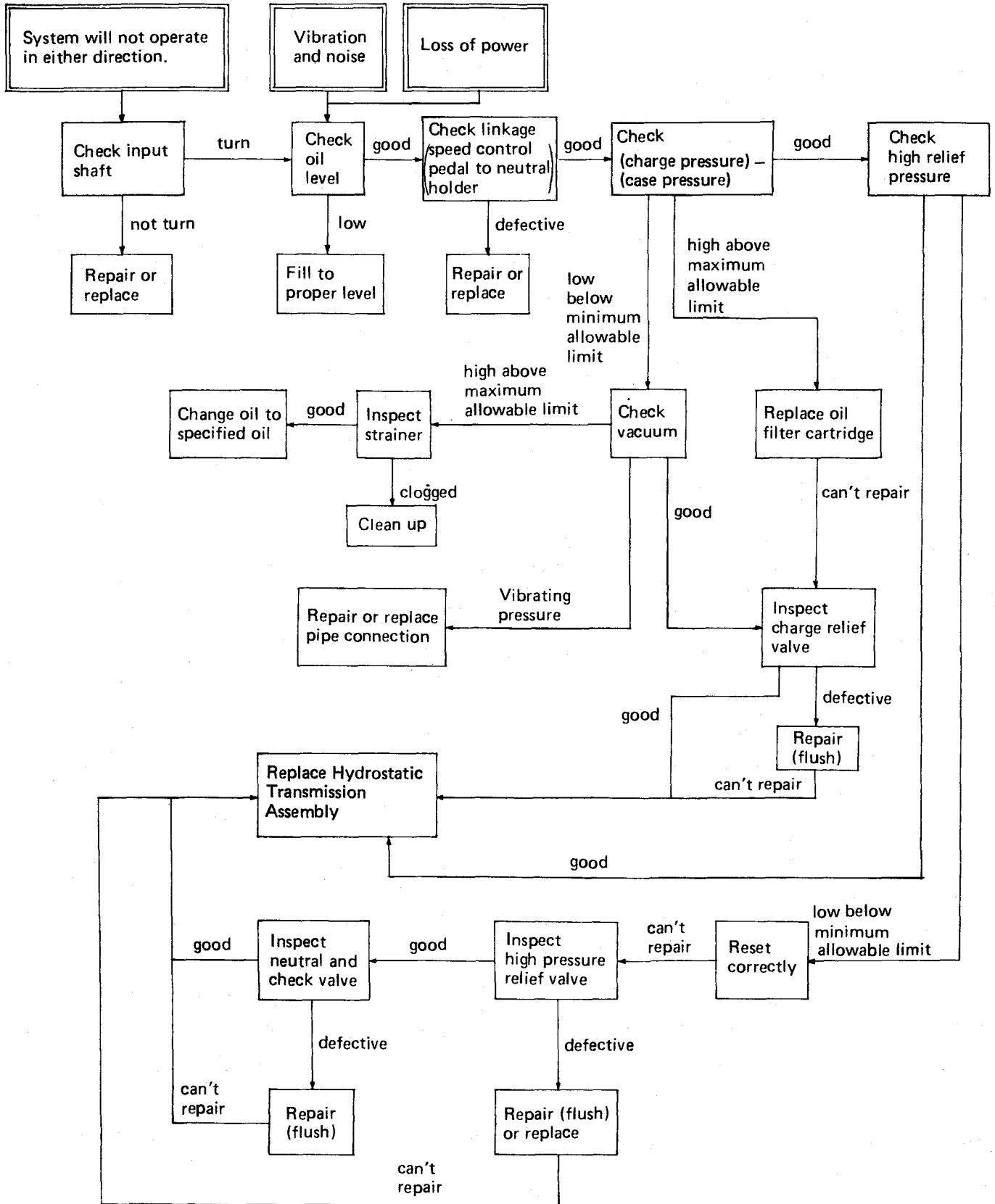

# TROUBLESHOOTING (Continued)

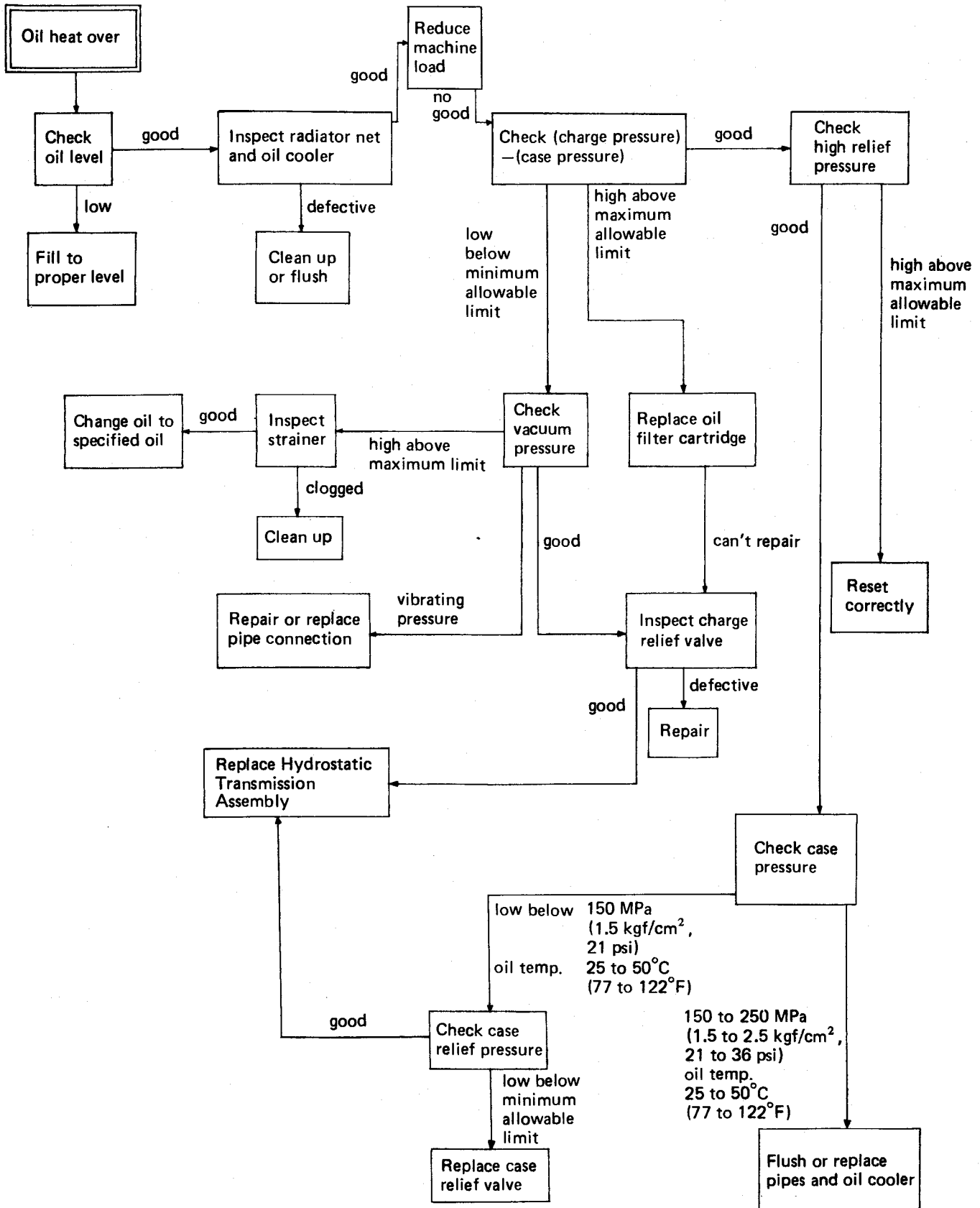



# TROUBLESHOOTING (Continued)

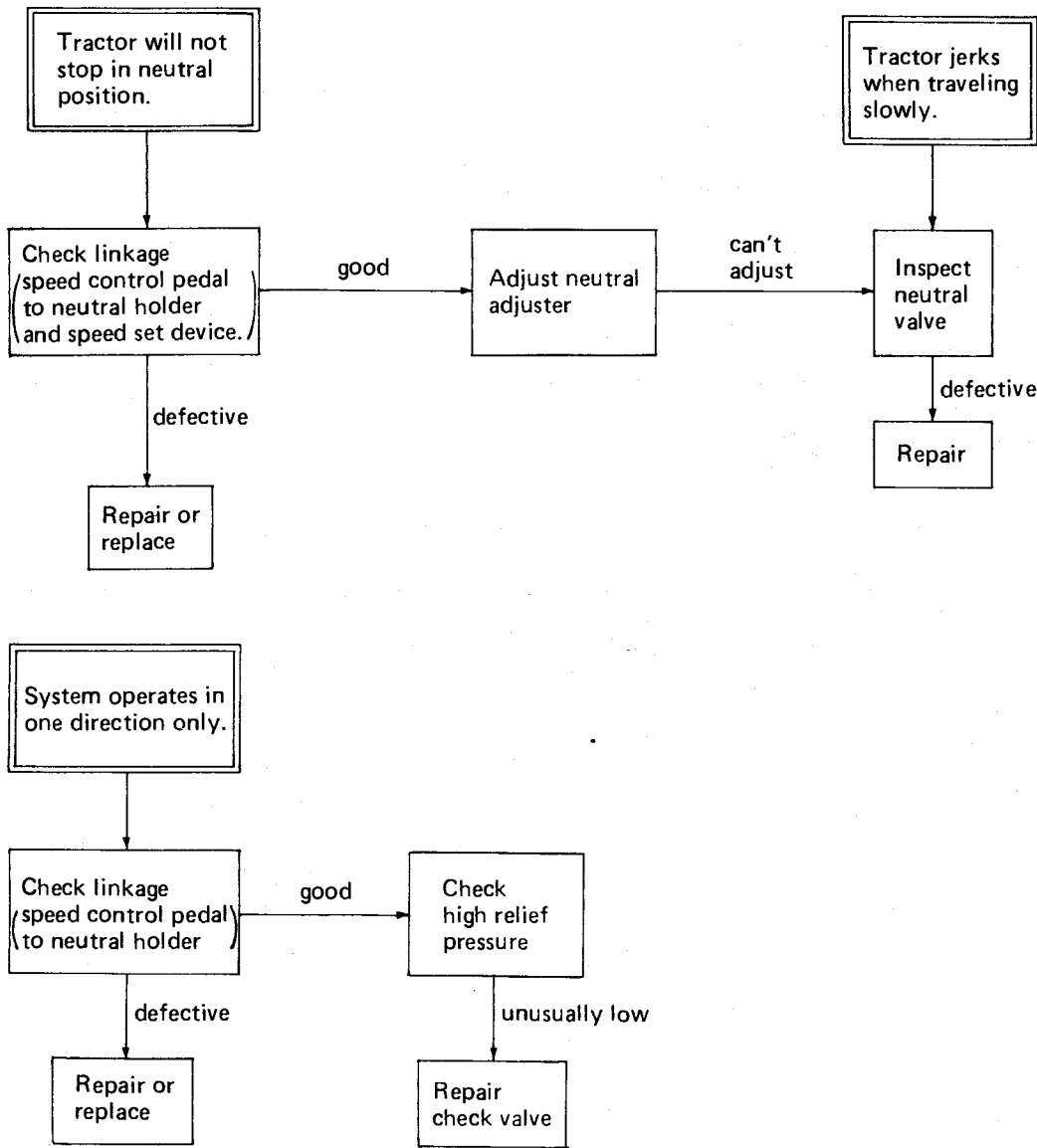

## TROUBLESHOOTING (Continued)

Symptom	Probable Cause	Solution	Reference Page
Noise from Transmission	● Transmission oil insufficient	Refill	S.G-7,S.S-2
	● Gear worn or broken	Replace	S.2-11
	● Improper backlash between ring gear spiral bevel pinion shaft	Adjust	S.2-9
Gear Slip out of Mesh	● Bearings worn	Replace	S.2-9
	● Shift fork spring tension insufficient	Replace	S.2-9
● Shift fork or shifter worn	Replace		
● Shift fork bent	Replace		

## SERVICING SPECIFICATIONS

Item	Factory Specification	Allowable Limit
Speed Set Lever	Force (See page S.2-6)	—
High Relief Valve	29.4 to 34.3 N 3.0 to 3.5 kgf 6.6 to 7.7 lbs	—
High Relief Valve	Setting Pressure	22.6 to 24.5 MPa 230 to 250 kgf/cm <sup>2</sup> 3271 to 3555 psi (Oil temperature at 25° to 50°C 77° to 122°F)
High Relief Valve Spring	Free Length	21.6 or 25.5 MPa 220 or 260 kgf/cm <sup>2</sup> 3128 or 3697 psi (Oil temperature at 25° to 50°C 77° to 122°F)
	Setting Length	—
	—	—
Case Relief Valve	40.0 mm 1.575 in.	—
	Setting Length	—
Case Relief Valve Spring	34.0 mm 1.339 in. (load 612 N 62.4 kgf 138 lbs)	—
	32.5 mm 1.280 in. (load 765 N 78.0 kgf 172 lbs)	—
Case Relief Valve	Setting Pressure	167 to 226 kPa 1.7 to 2.3 kgf/cm <sup>2</sup> 24 to 33 psi (Oil temperature at 25° to 50°C 77° to 122°F)
Case Relief Valve Spring	Free Length	147 or 245 kPa 1.5 or 2.5 kgf/cm <sup>2</sup> 21 or 36 psi (Oil temperature at 25° to 50°C 77° to 122°F)
Case Relief Valve Spring	Free Length	—
Case Relief Valve Spring	Free Length	25.95 mm 1.022 in.

**SERVICING SPECIFICATIONS (Continued)**

Item		Factory Specification	Allowable Limit
Case Relief Valve Spring	Setting Length	20.0 mm 0.787 in. (load 29.4 N 3.00 kgf 6.62 lbs)	—
		17.5 mm 0.689 in. (load 41.8 N 4.26 kgf 9.39 lbs)	—
Charge	Setting Pressure	441 to 579 kPa 4.5 to 5.9 kgf/cm <sup>2</sup> 64 to 84 psi more than case pressure (Oil temperature at 25°C, 77°F)	412 or 608 kPa 4.2 or 6.2 kgf/cm <sup>2</sup> 60 or 88 psi more than case pressure (Oil temperature at 25°C, 77°F)
		422 to 559 kPa 4.3 to 5.7 kgf/cm <sup>2</sup> 61 to 81 psi more than case pressure (Oil temperature at 50°C, 122°F)	392 or 558 kPa 4.0 or 6.0 kgf/cm <sup>2</sup> 57 or 85 psi more than case pressure (Oil temperature at 50°C, 122°F)
Vacuum	Setting Pressure	120 mmHg (Oil temperature at 25°C, 77°F)	—
		60 mmHg (Oil temperature at 50°C, 122°F)	—
		35 mmHg (Oil temperature at 80°C, 176°F)	220 mmHg (Oil temperature at 80°C, 176°F)
Neutral Valve Spring (1)	Free Length	19.71 mm 0.7770 in.	—
	Setting Length	15.0 mm 0.591 in. (load 27 N 2.7 kgf 6.0 lbs)	—
		11.0 mm 0.43 in. (load 49.0 N 5.0 kgf 11 lbs)	—

**SERVICING SPECIFICATIONS (Continued)**

Item		Factory Specification	Allowable Limit
Neutral Valve Spring (2)	Free Length	29.7 mm 1.169 in.	—
	Setting Length	15.0 mm 0.591 in. (load 17 N 1.7 kgf 3.7 lbs)	—
Check Valve Spring	Free Length	26.91 mm 1.183 in.	—
	Setting Length	19.5 mm 0.768 in. (load 3.128 N 0.319 kgf 0.763 lbs)	—
Piston to Bore	Clearance	11.0 mm 0.43 in. (load 21.18 N 2.16 kgf 4.76 lbs)	—
		0.02 mm 0.0008 in.	0.004 mm 0.0016 in.
Slipper	Thickness	3.00 mm 0.118 in.	2.90 mm 0.114 in.

**SERVICING SPECIFICATIONS (Continued)**

Item		Factory Specification	Allowable Limit
Gears	Backlash	0.10 to 0.20 mm 0.004 to 0.008 in.	0.4 mm 0.016 in.
Gear to Spline	Clearance	0.03 to 0.08 mm 0.0012 to 0.0031 in.	0.20 mm 0.0079 in.
20T-12T Gear to High-low Shift Fork	Clearance	0.10 to 0.30 mm 0.004 to 0.018 in.	0.50 mm 0.020 in.
21T Gear to PTO Shift Fork	Clearance	0.10 to 0.30 mm 0.004 to 0.018 in.	0.5 mm 0.020 in.
24T Gear to Shift Lever	Clearance	0.10 to 0.30 mm 0.004 to 0.018 in.	0.5 mm 0.020 in.
29T-14T-18T Gear to 2nd Shaft	Clearance	0.007 to 0.053 mm 0.0003 to 0.0021 in.	0.10 mm 0.0039 in.
2nd Shaft	O.D.	21.987 to 22.000 mm 0.8656 to 0.8661 in.	—
29T-14T-18T Gear	I.D.	28.007 to 28.028 mm 1.1026 to 1.1035 in.	—
Needle	O.D.	2.994 to 3.000 mm 0.1179 to 0.1181 in.	—
17T, 21T Gear to 3rd Shaft	Clearance	0.007 to 0.047 mm 0.0003 to 0.0019 in.	0.10 mm 0.0039 in.
3rd Shaft	O.D.	24.987 to 25.000 mm 0.9837 to 0.9842 in.	—
17T, 21T Gear	I.D.	29.007 to 29.028 mm 1.1420 to 1.1428 in.	—
Needle	O.D.	1.997 to 2.000 mm 0.0786 to 0.0787 in.	—
PTO Shaft	Initial Turning Torque	0.49 to 1.47 N-m 0.05 to 0.15 kgf-m 0.36 to 1.08 ft-lbs	—
Adjusting Shim	Thickness	0.3 mm, 0.012 in. 0.4 mm, 0.016 in. 0.5 mm, 0.020 in.	— — —
Ring Gear to Spiral Bevel Pinion Shaft	Backlash	0.10 to 0.20 mm 0.004 to 0.008 in.	0.4 mm 0.016 in.
Adjusting Shim	Thickness	0.2 mm, 0.008 in. 0.3 mm, 0.012 in. 0.5 mm, 0.020 in.	— — —

## TIGHTENING TORQUES

Screws and Nuts	Tightening Torque		
	N-m	kgf-m	ft-lbs
Neutral adjuster	19 to 32	1.9 to 3.3	13.7 to 23.9
Trunnion shaft cover	2.0 to 2.5	0.20 to 0.26	1.45 to 1.83
Charge pump	10.8 to 13.7	1.62 to 1.98	8.0 to 10.1
Motor swashplate	15.7 to 20.6	1.6 to 2.1	12 to 15
Port-block	23 to 27	3.15 to 3.85	17 to 20
High relief valve seat	24 to 29	2.4 to 3.0	17.4 to 21.7
High relief valve cap nut	58.8 to 68.6	6.0 to 7.0	43.4 to 50.6
Case relief valve nut	1.67 to 2.26	0.17 to 0.23	1.23 to 1.66
Plug (Drain)	49.0 to 58.8	5.0 to 6.0	36.2 to 43.4
Plug (P1, P2)	19.6 to 24.5	2.0 to 2.5	14.5 to 18.1
Plug (P1, P2) PT 3/8	29.4 to 39.2	3.0 to 4.0	21.7 to 28.9
Plug seat (P1, P2)	49.0 to 58.8	5.0 to 6.0	36.2 to 43.4
Plug (P3, P4, P5)	8.8 to 10.8	0.9 to 1.1	6.5 to 8.0
HST case to transmission case	48.1 to 55.9	4.9 to 5.7	35.4 to 41.2
Mid PTO case Bearing holder Case cover to case	13.7 to 19.6	1.4 to 2.0	10.1 to 14.5
Mid PTO case to transmission case	48.1 to 55.9	4.9 to 5.7	35.4 to 41.2
Rear cover mounting screw	39.2 to 64.7	4.0 to 6.6	28.9 to 47.7
PTO shaft screw	18.6 to 32.4	1.9 to 3.3	13.7 to 23.9

# DISASSEMBLY AND SERVICING

## [1] SPEED SET DEVICE

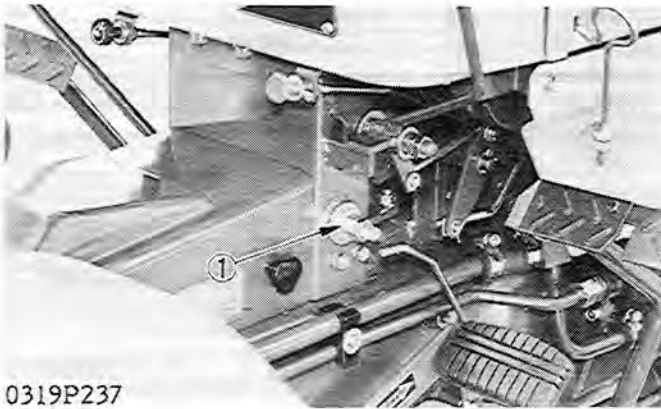

## DISASSEMBLY AND ASSEMBLY

### Speed Set Lever

1. Measure the force to move the speed set lever in the direction (A) at its top (grip).
2. If the force is not within the factory specification, turn the nut (1) to adjust.

Force to move the lever

Factory specification.....	29.4 to 34.3 N
	3.0 to 3.5 kgf
	6.6 to 7.7 lbs

### (When reassembling)

- After installing the spring (3), align the head of nut (2) with the punched mark (4).

- (1) Nut
- (2) Nut
- (3) Spring
- (4) Punched Mark

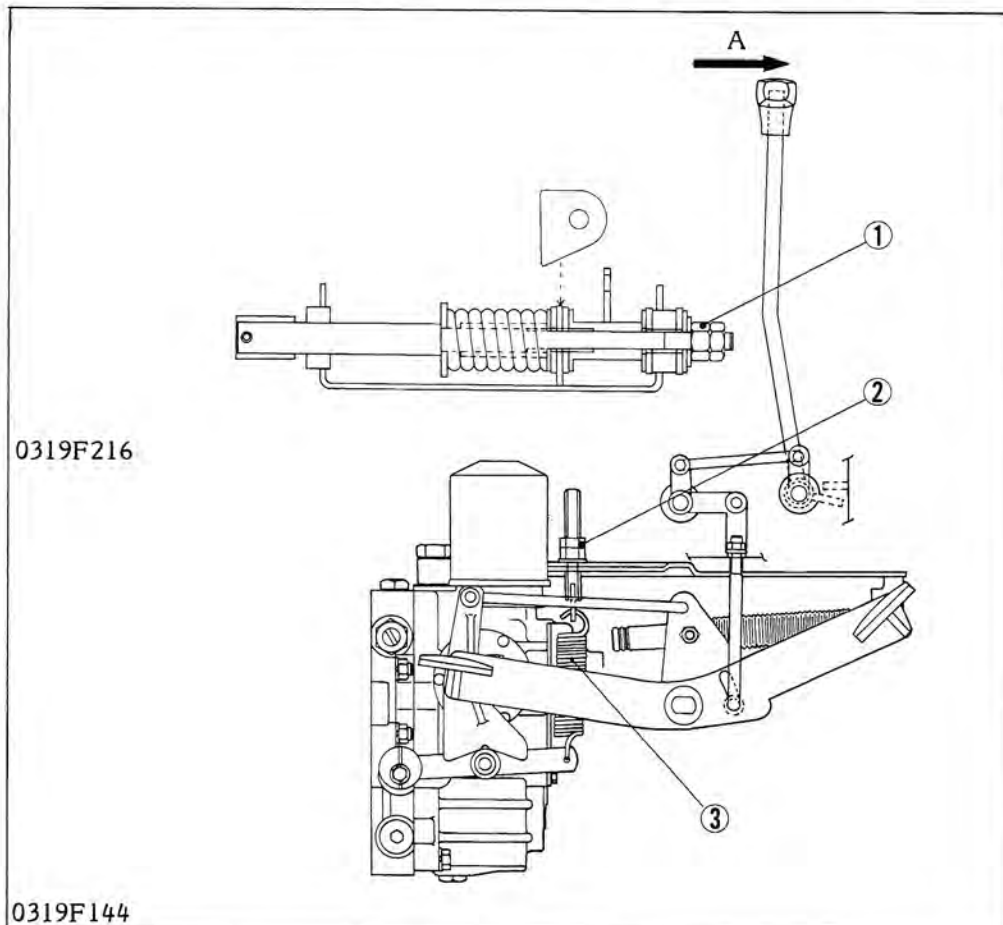

[2] HYDROSTATIC TRANSMISSION (HST)

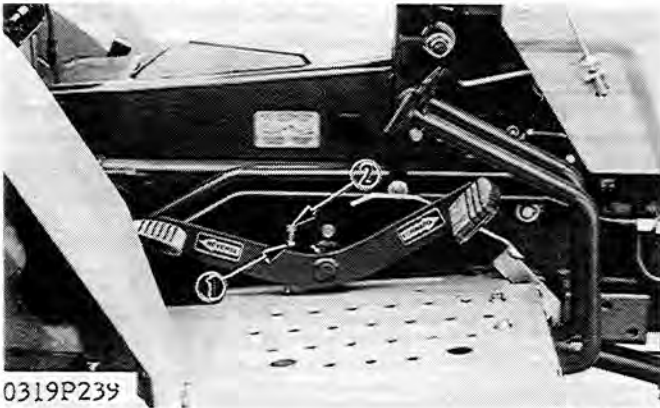

0319P239

(1) Lock Nut

(2) Bolt



0319P239

0319P240

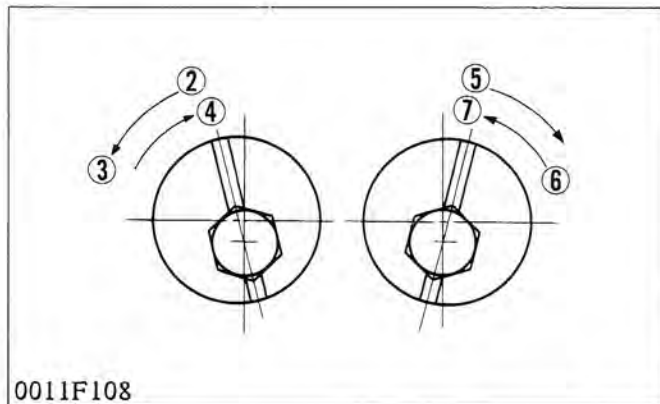

0011F108



0319P241

CHECKING AND ADJUSTMENT

Reverse Speed

1. Lift the rear of the tractor so that the rear wheels are off the ground.
2. Set the engine speed at 2500 rpm and depress the differential lock pedal.
3. If the rear wheels do not turn within the factory specifications, loosen the lock nut (1) and adjust the bolt (2).

Rear wheel rpm

Factory specification..... 64 to 68 rpm  
(Engine 2500 rpm)

**CAUTION**

- Lift the tractor preventing it from dropping out of jacks.
- Shift the front wheel drive shaft lever to neutral position.

Neutral

1. Lift the rear of the tractor so that the rear wheels are off the ground and run the engine at low idling and drive only rear wheels.
2. Depress the one end of speed control pedal and release, and do the same at the other end.
3. If the rear wheels do not stop turning, adjust as following procedure.

**NOTE**

- Loosen the screw and be sure to place the neutral adjuster with its longer groove upward.

Adjusting Neutral

1. Rotate the neutral adjuster counterclockwise so that the rear wheels turn forward.
2. Then rotate it clockwise until wheels stop completely.
3. Put a mark on the clutch housing aligning the groove on neutral adjuster.
4. Rotate the neutral adjuster clockwise so that the rear wheels turn reverse.
5. Then rotate it counterclockwise until wheels stop completely.
6. Put a mark on the clutch housing aligning the groove on neutral adjuster.
7. Hold the neutral adjuster so that its groove is at the middle of the marks and tighten the screw.

**NOTE**

- When the wheels tend to turn forward, rotate the neutral adjuster clockwise.
- When the wheels tend to turn reverse, rotate the neutral adjuster counterclockwise.

**(Tightening torque)**

Neutral adjuster to case.... 19 to 32 N·m  
1.9 to 3.3 kgf·m  
13 to 24 ft·lbs





0319P239

(1) Sub Cover

(2) Knob Screw

**Oil pressure in Hydrostatic Transmission**

1. Clean and clear the work area, and fully engage the parking brake.
2. Remove the knob screws (2) and sub cover (1).
3. Measure the following oil pressures using Hydrostatic Transmission Testing Kit (Code No.07916-52040) as instructed.

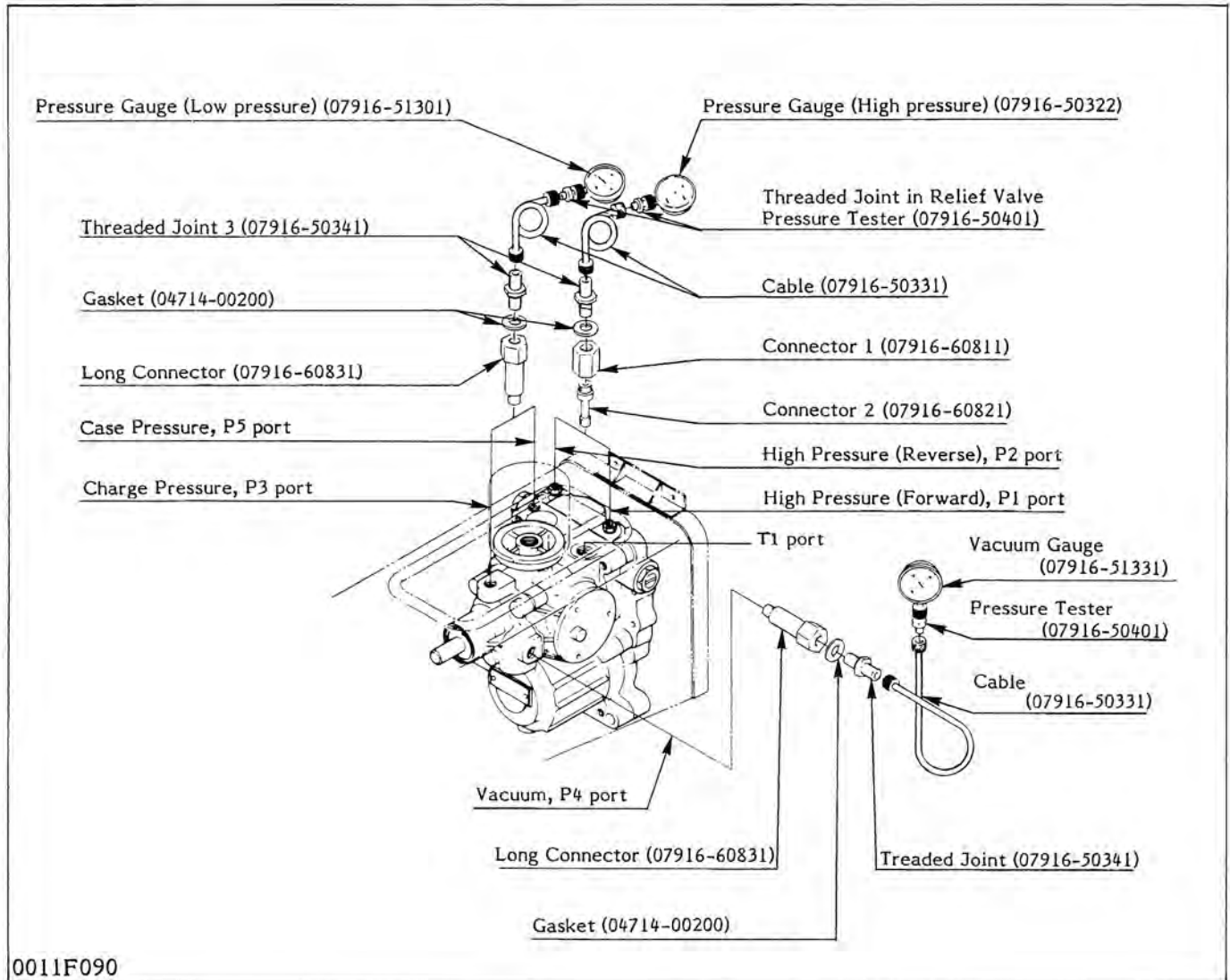

0011F090

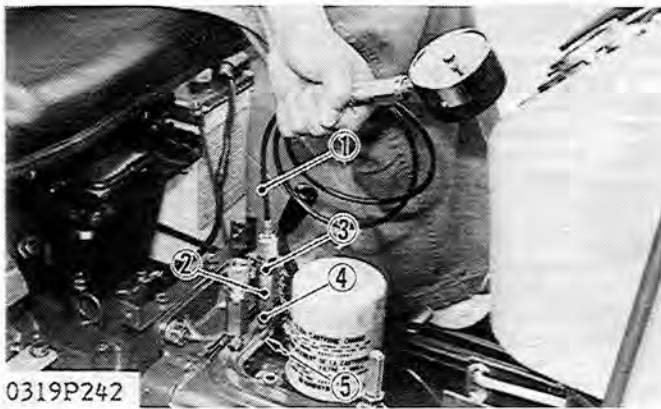
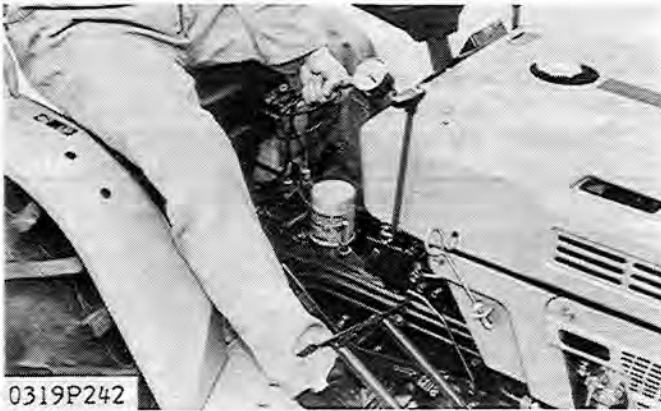

- (1) Cable
- (2) Connector 1
- (3) Threaded Joint
- (4) Connector 2
- (5) P2 Port
- (6) P1 Port

**(1) High Relief Pressure**

1. Remove the M 10 hex socket head plug from P1 (6) or P2 (5) port (P1 is for forward and P2 is for reverse).
2. Install connector 2 (4) to P1 (forward) or P2 (reverse) port.
3. Assemble connector 1 (2) and threaded joint (3) with the gasket between them.
4. Install the assembled connector 1 (2) and threaded joint (3) to connector 2 (4).
5. Install the cable (1), threaded joint in relief valve set pressure tester and high pressure gauge to threaded joint (3) in order.
6. Run the engine at 2600 to 2700 rpm.
7. Place the high-low shift lever in high.
8. Depress the speed control pedal approx. 10 mm (0.39 in.) which rotates the trunnion shaft 0,087 rad (5.0°).

**■ IMPORTANT**

- Measure quickly so that the relief valve may not be in operation more than 10 seconds.

**■ NOTE**

- High pressure gauge is 30 MPa (300 kgf/cm<sup>2</sup>, 4260 psi) full scale.

**(When reassembling)**

- Install the M 10 plug to the port with the gasket laying on its seat.

High Relief Pressure (Oil temperature at 25° to 50°C, 77° to 122°F)

Factory specification.....	22.6 to 24.5 MPa 230 to 250 kgf/cm <sup>2</sup> 3271 to 3555 psi
Allowable limit.....	21.6 or 25.5 MPa 220 or 260 kgf/cm <sup>2</sup> 3128 or 3697 psi

**(Tightening torque)**

Plug (P1, P2 port).....	20 to 25 N-m 2.0 to 2.5 kgf-m 14 to 18 ft-lbs
Plug seat (P1, P2 port).....	55 to 59 N-m 5.6 to 6.0 kgf-m 41 to 43 ft-lbs

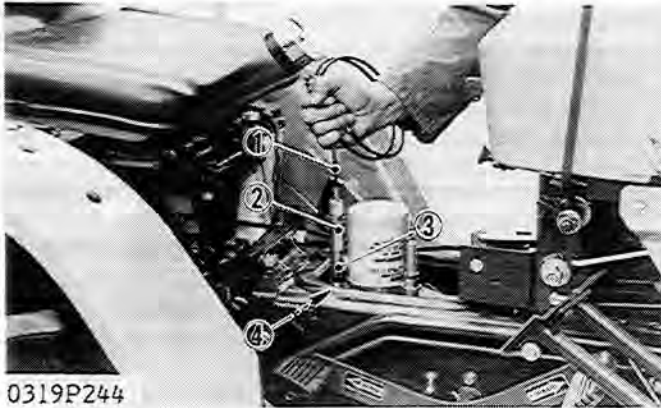

0319P244

- (1) Cable
- (2) Threaded Joint
- (3) Long Connector
- (4) P5 Port

**(2) Case and Case Relief Pressure**

1. Remove the PT 1/4 plug from P5 port (4), with care not to allow any particle of sealing tape enter into the port.
2. Install the long connector (3) to P5 port with sealing tape on its thread.
3. Install the threaded joint (2) to long connector with the gasket between them.
4. Install the cable (1), threaded joint in relief valve set pressure tester and low pressure gauge to threaded joint in order.
5. Run the engine at 2600 to 2700 rpm.
6. Place the high-low shift lever in neutral.
7. Release the speed control pedal to set in neutral.
8. After measuring the case pressure, remove the eye joint from T1 port and plug the port with PF 3/8 screw to measure the case relief pressure.

**NOTE**

- Low pressure gauge is 2 MPa (20 kgf/cm<sup>2</sup>, 284 psi) full scale.

**(When reassembling)**

- Install the PT 1/4 plug to the P3 port with the sealing tape on its thread.

Case Relief Pressure (Oil temperature at 25° to 50°C, 77° to 122°F)

Factory specification.....	166 to 226 kPa
	1.7 to 2.3 kgf/cm <sup>2</sup>
	24.2 to 32.7 psi
Allowable limit.....	147 or 245 kPa
	1.5 or 2.5 kgf/cm <sup>2</sup>
	21.3 or 35.6 psi

**(Tightening torque)**

Plug (P5 port).....	8.8 to 10.8 N-m
	0.9 to 1.1 kgf-m
	6.5 to 7.9 ft-lbs

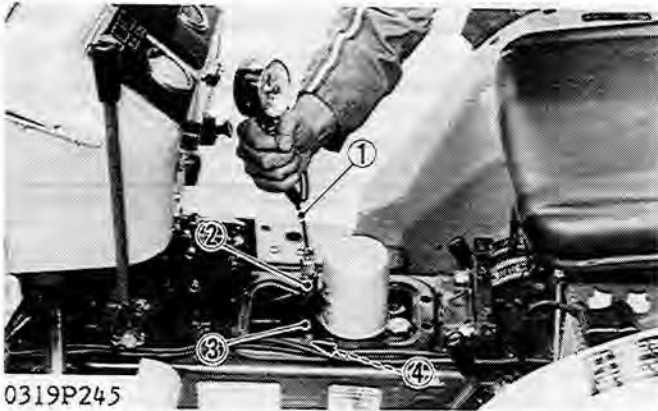

0319P245

- (1) Cable
- (2) Threaded Joint
- (3) Long Connector
- (4) P3 Port

**(3) Charge Pressure**

1. Remove the PT 1/4 plug from P3 port (4), with care not to allow any particle of sealing tape enter into the port.
2. Install the long connector (3) to P3 port with sealing tape on its thread.
3. Install the threaded joint (2) to long connector with the gasket between them.
4. Install the cable (1) and threaded joint in order.
5. Run the engine at 2800 to 3000 rpm.
6. Place the high-low shift lever in neutral.
7. Release the speed control pedal to set in neutral.

**■ NOTE**

- Low pressure gauge is 2 MPa (20 kgf/cm<sup>2</sup>, 284 psi) full scale.

**(When reassembling)**

- Install the PT 1/4 plug to the P3 port with the sealing tape on its thread.

**Charge Pressure (Oil temperature at 25°C, 77°F)**

Factory specification.....	441 to 579 kPa
	4.5 to 5.9 kgf/cm <sup>2</sup>
	64.2 to 83.9 psi
Allowable limit.....	412 or 608 kPa
	4.2 or 6.2 kgf/cm <sup>2</sup>
	59.7 or 88.2 psi

**Charge Pressure (Oil temperature at 50°C, 122°F)**

Factory specification.....	421 to 559 kPa
	4.3 to 5.7 kgf/cm <sup>2</sup>
	61.1 to 81.1 psi
	more than case pressure
Allowable limit.....	392 or 558 kPa
	4.0 or 6.0 kgf/cm <sup>2</sup>
	56.9 or 65.3 psi
	more than case pressure

**(Tightening torque)**

Plug (P3 port).....	8.8 to 10.8 N-m
	0.9 to 1.1 kgf-m
	6.5 to 7.9 ft-lbs



0319P246

- (1) P4 Port
- (2) Long Connector
- (3) Threaded Joint
- (4) Cable

**(4) Vacuum**

1. Remove the PT 1/4 plug from P4 port (1) with care not to allow any particle of sealing tape enter into the port.
2. Install the long connector (2) to P4 port with sealing tape on its thread.
3. Install the threaded joint (3) to long connector with the gasket between them.
4. Install the cable (4), threaded joint in relief valve set pressure tester and vacuum gauge to threaded joint (3) in order.
5. Run the engine at 2800 to 3000 rpm.
6. Place the high-low shift lever in neutral.
7. Release the speed control pedal to set in neutral.

**■ NOTE**

- Vacuum gauge is 760 mmHg (30 in.Hg) full scale.

**(When reassembling)**

- Install the PT 1/4 plug to the P4 port with the sealing tape on its thread.

**Vacuum (Oil temperature)**

Factory specification.....	120 mmHg (at 25°C, 77°F)
	60 mmHg (at 50°C, 122°F)
	35 mmHg (at 80°C, 176°F)
Allowable limit.....	220 mmHg (at 80°C, 176°F)

**(Tightening torque)**

Plug (P3 port).....	8.8 to 10.8 N-m 0.9 to 1.1 kgf-m 6.5 to 7.9 ft-lbs
---------------------	--

**DISASSEMBLY AND ASSEMBLY**

**Hydrostatic Transmission (HST)**

1. Remove the propeller shaft (4) from the 1st shaft (3).
2. Remove the drive shaft (6) from the front wheel drive shaft (2). (4WD type only)
3. Loosen the hose clamp and remove the hose (5).
4. Remove the HST mounting screws, and remove the HST (1).

**(When reassembling)**

- After inserting the spring pin into the 1st shaft and drive shaft, lock the spring pin with a wire.
- Be sure to replace the gasket with a new one.

**(Tightening torque)**

- HST mounting screw..... 48 to 56 N-m  
4.9 to 5.7 kgf-m  
35.4 to 41.2 ft-lbs

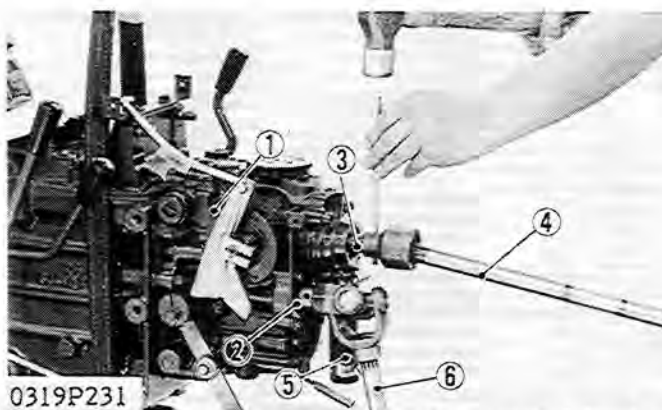

0319P231

- (1) HST
- (2) Front Wheel Drive Shaft
- (3) 1st Shaft
- (4) Propeller Shaft
- (5) Hose
- (6) Drive Shaft

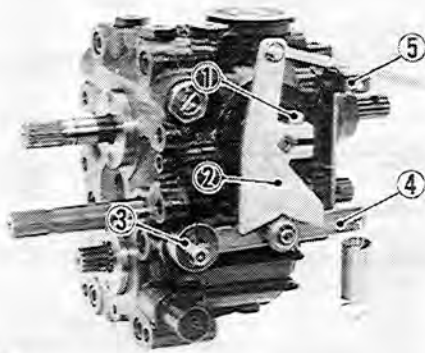

0319P256

- (1) Screw
- (2) Neutral Holder
- (3) Neutral Adjuster
- (4) Neutral Holder Arm
- (5) Spring Holder

**Neutral Holder**

1. Place parting marks on the neutral adjuster (3) and the neutral holder arm (4).
2. Remove the screws and spring holder (5).
3. Remove the screw and the neutral holder arm (4).
4. Remove the screw (1) and pull out the neutral holder (2).

**(When reassembling)**

- Aligning the parting marks, install the neutral adjuster and the neutral holder arm.

**(Tightening torque)**

Screw (1).....	19 to 32 N-m
(neutral adjuster to case)	1.9 to 3.3 kg-m
	14 to 24 ft-lbs

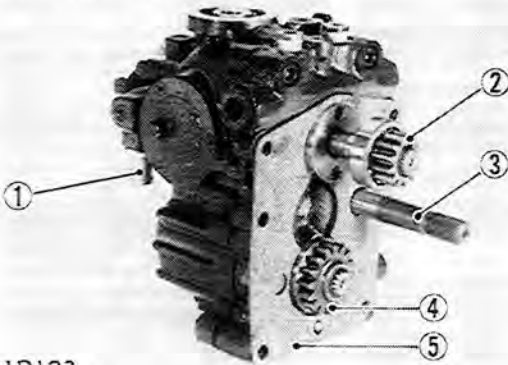

0011P123 :

- (1) Hose Joint
- (2) 13T Gear
- (3) Front Wheel Drive Shaft 1
- (4) 16T Gear
- (5) Gasket

**Front Wheel Drive Shaft 1 and Gears**

1. Pull out the front wheel drive shaft 1 (3) forward.
2. Remove the external circlip and 13T gear (2).
3. Remove the external circlip and 16T gear (4).
4. Remove the hose joint (1) and gasket (5).

**(When reassembling)**

- Install the circlip with its rounded edge facing the gear or bearing so that its sharp edge in the groove keeps itself in place against the force.

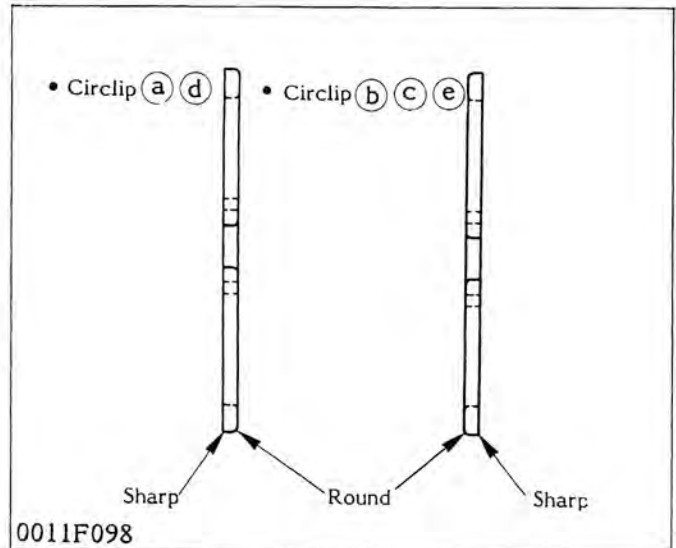
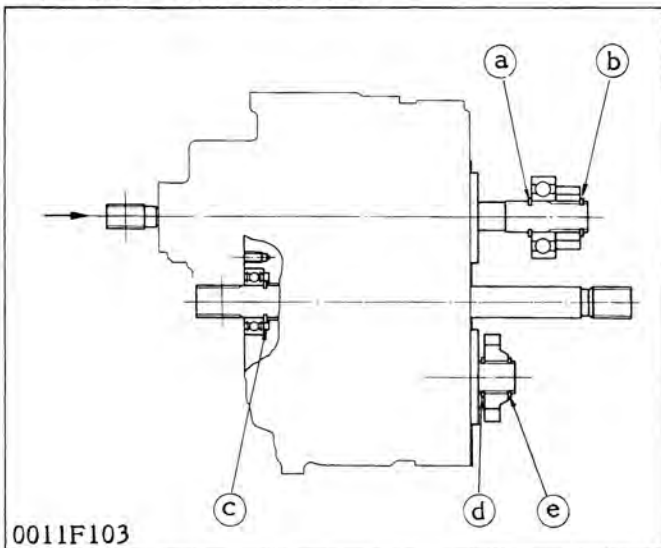

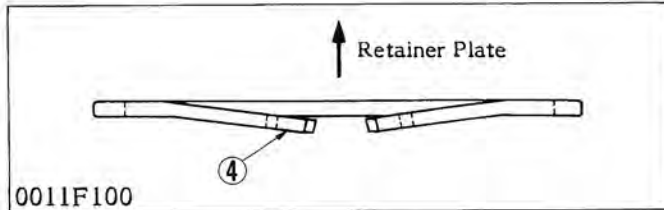

0011F100

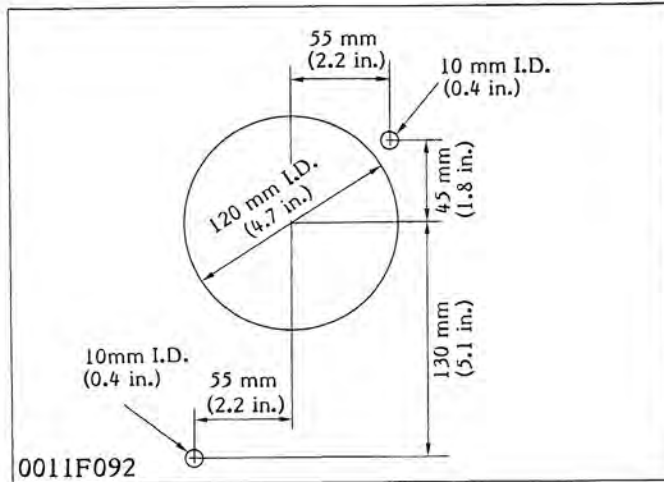

0011F092

**Repair-stand for assembly and disassembly**

To facilitate disassembly and assembly, make a repair stand as shown in the figure.

**IMPORTANT**

- Clean the repair-stand and the outside of the hydrostatic transmission case.
- Hydrostatic transmission is composed of many precision parts and they have highly finished or polished surface.
- Take extreme care to prevent damage or dirt during disassembly and assembly.
- Coat hands with hydrostatic transmission oil before handling the parts to minimize the possibility of rust.
- Clean the parts and coat them with hydrostatic transmission oil before assembling.

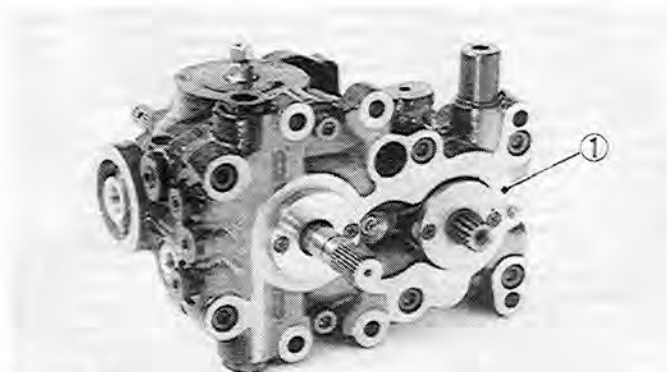

0011P124

(1) Port Block

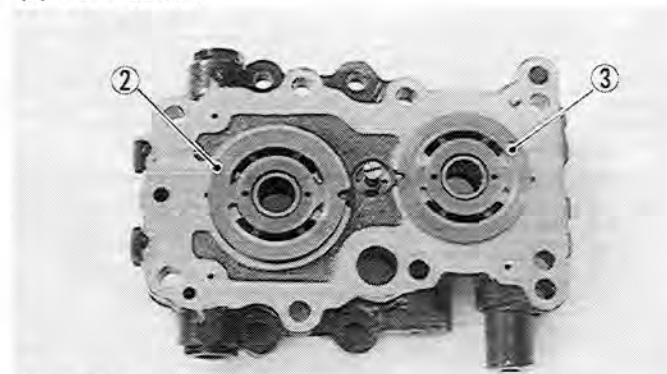

0011P126

(2) Pump Valve Plate

(3) Motor Valve Plate

**Port Block**

1. Remove the port block mounting screws, and tap the front of port block (1) flange with a soft hammer to separate.

**(When reassembling)**

- Cover the splines of each shaft with thin tape to protect the sealing lip.
- Install port block with gasket, O-ring and valve plate in place.

**IMPORTANT**

- Valve plates (2), (3) may stick to the port block, but they are not fixed. take care not to drop them.
- Valve plates are not inter changeable. Valve plate of the pump has two notches and the valve of the motor has no notches.

**(Tightening torque)**

Port block to case..... 23 to 27 N-m  
 2.3 to 2.8 kgf-m  
 17 to 20 ft-lbs

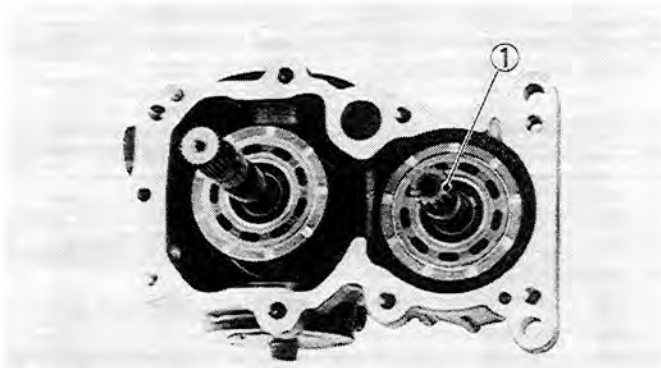

0011P147

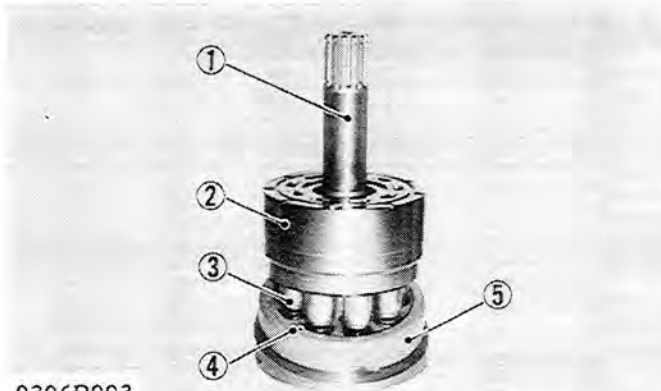

0306P003

- |                          |                     |
|--------------------------|---------------------|
| (1) Output Shaft         | (4) Retainer Plate  |
| (2) Motor Cylinder Block | (5) Retainer Holder |
| (3) Piston               |                     |

**Motor Cylinder Block**

1. Hold the output shaft (1) and slightly tap the rear of case flange with a soft hammer to separate the motor cylinder block assembly.
2. Slide out the motor cylinder block (2) with pistons (3), retainer plate (4) and retainer holder (5).

**(When reassembling)**

- Aligning the hole on the swashplate to the dowel pin in the case, and install the output shaft assembly in the case.



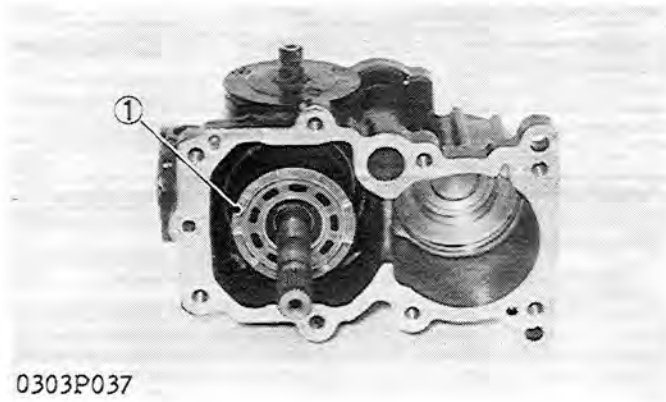

**Pump Cylinder Block**

1. Remove the internal circlip retaining the retainer plate of pump.
2. Slide out pump cylinder block (1) with pistons (3) retainer plate (2) and internal circlip (4).
3. Draw out the thrust plate from the variable swashplate.

**(When reassembling)**

- Check that internal circlip (4) faces correct in the direction, and install it to pump swashplate.
- Squeeze the circlip (4) and slip into the hole its arc first by pushing down with a screwdriver to fit surely.

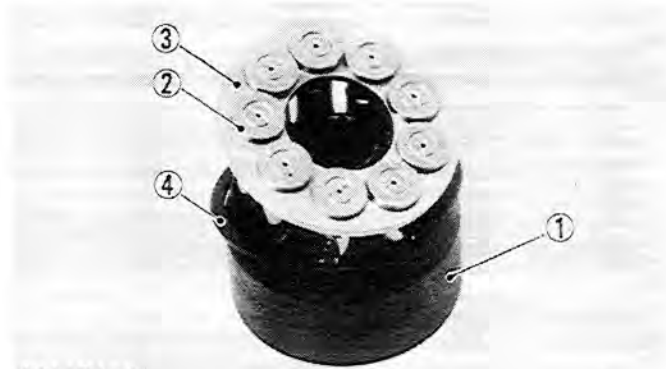

- |                         |             |
|-------------------------|-------------|
| (1) Pump Cylinder Block | (3) Piston  |
| (2) Retainer Plate      | (4) Circlip |

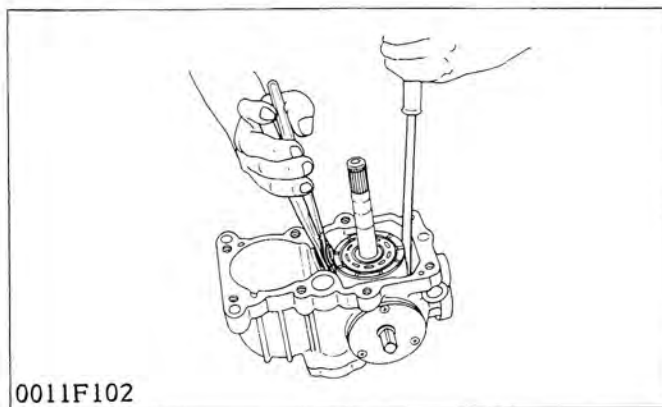
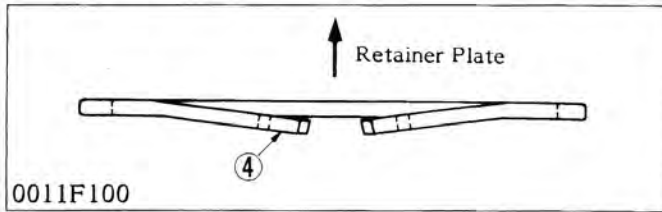

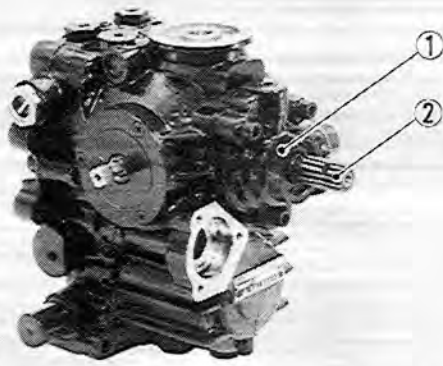

0319P257

(1) Charge Pump Case

(2) Input Shaft

**Charge Pump and Input Shaft**

1. Remove the screws retaining the charge pump case (1).
2. Tapping the rear end of the input shaft (2) with a soft hammer, separate the charge pump case (1) with the input shaft (2) from the case.
3. Remove two knock pins.

**(Tightening torque)**

Screw..... 11 to 14 N-m  
 (Charge pump case to case) 1.1 to 1.4 kgf-m  
 8.0 to 10.1 ft-lbs

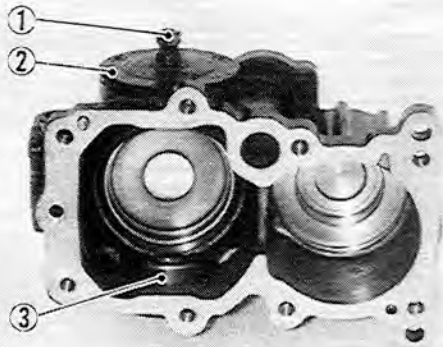

0303P039

**Pump Swashplate**

1. Remove the screws retaining trunnion shaft cover.
2. Tap the end of trunnion shaft (1) with a soft hammer to separate the trunnion shaft cover 2 (3).
3. Tap the end of shaft with a soft hammer to separate the trunnion shaft cover 1 (2).

**(When reassembling)**

- Install the trunnion shaft covers (2), (3) with the seam of bearing (4), (5) facing forward (machined surface side of case).

**(Tightening torque)**

Screw..... 2.0 to 2.5 N-m  
 (Trunnion shaft cover to case) 0.20 to 0.26 kgf-m  
 1.4 to 1.9 ft-lbs

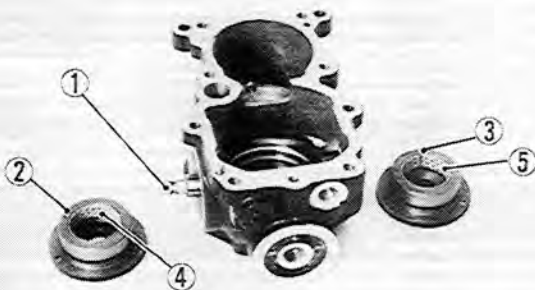

0011P141

(1) Trunnion Shaft

(2) Trunnion Shaft Cover 1

(3) Trunnion Shaft Cover 2

(4) Seam of Bearing

(5) Seam of Bearing

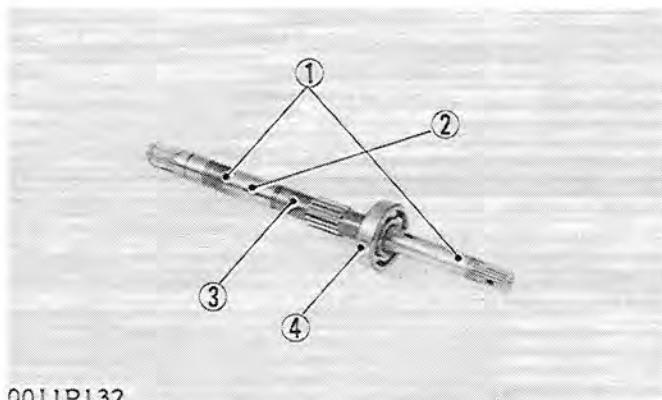

0011P132

- (1) Seal Surface
- (2) Bearing Surface
- (3) Input Shaft
- (4) Bearing

**SERVICING**

**Input Shaft**

1. Pull out the input shaft (3) with the bearing on it from the charge pump case.
2. Check the seal surface (1), the bearing surface (2) and the bearing (4).
3. If the shaft is rough or grooved, replace.
4. If the bearing is worn, replace.

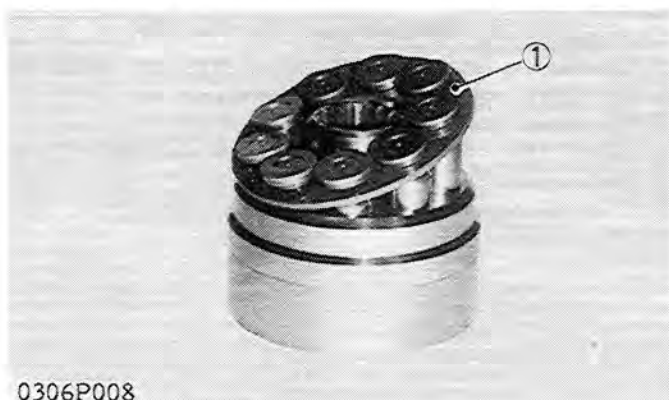

0306P008

- (1) Retainer Plate

**Cylinder Block Bore and Pistons**

1. Lift all the pistons gently with the retainer plate (1).
2. Check the pistons for their free movement in the cylinder block bores.
3. If the piston or the cylinder block bore is scored, replace the cylinder block assembly.

**IMPORTANT**

- Do not interchange pistons between pump and motor cylinder block. Pistons and cylinder blocks are matched.

Clearance between piston and bore  
 Factory specification..... 0.02 mm  
 0.0008 in.

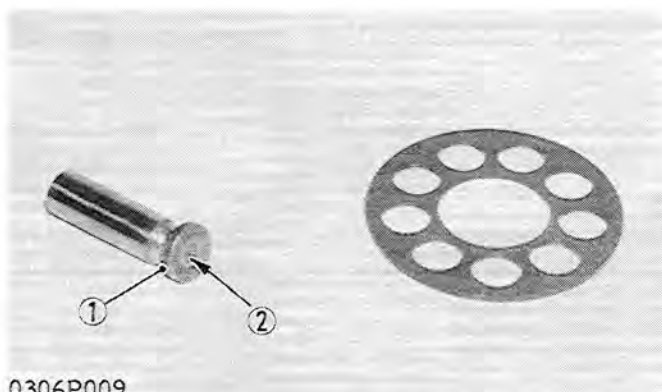

0306P009

- (1) Piston Slipper
- (2) Lubricant Hole

**Piston Slipper and Retainer Plate**

1. Check the slipper (1) for flatness.
2. If rounded, replace.
3. Measure the thickness of piston slipper.
4. If the measurement is less than the allowable limit, replace.
5. Check the lubricant hole (2) for clogging.
6. If clogged, open hole with compressed air.

Thickness of slipper  
 Factory specification..... 3.00 mm  
 0.118 in.  
 Allowable limit..... 2.90 mm  
 0.114 in.

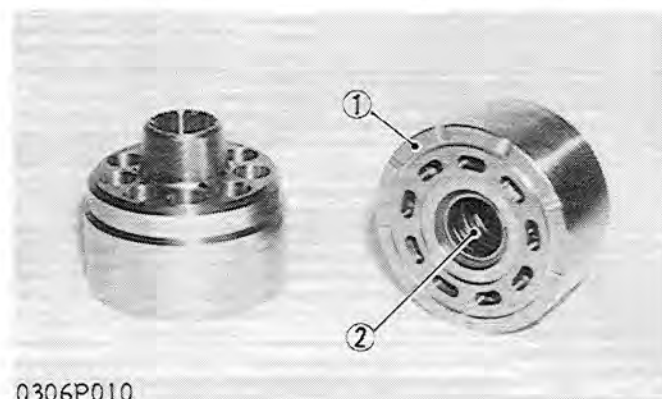

0306P010

- (1) Polished Face
- (2) Spring

**Cylinder Block Face**

1. Check the polished face (1) of cylinder block for scoring.
2. If scored, replace the cylinder block assembly.
3. Check the spring (2) for breakage.
4. If broken, replace the cylinder block assembly.

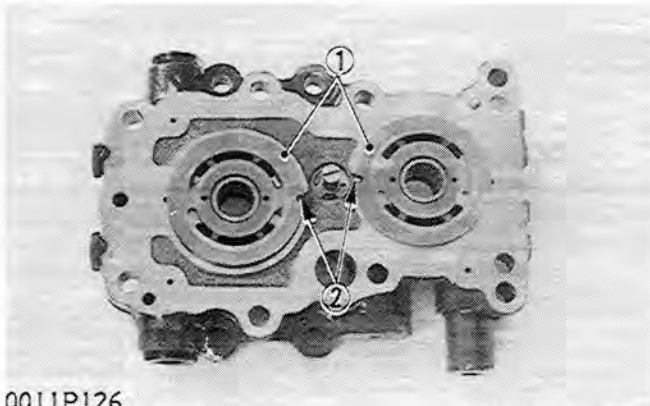

0011P126

(1) Valve Plate

(2) Anchor Pin

**Valve Plate**

1. Check the engagement of the valve plate (1) and the anchor pin (2).
2. Pushing the valve plate against the anchor pin, lift it to remove.
3. Check the valve plate for foreign particles.
4. Clean the valve plate and dry with compressed air.
5. Check the valve plate for scratches, wear and erosion.
6. If worn or scored, replace.

**NOTE**

- Run a finger nail across the valve plate surface. If worn, it will be felt. After checking, coat them with hydrostatic transmission oil.

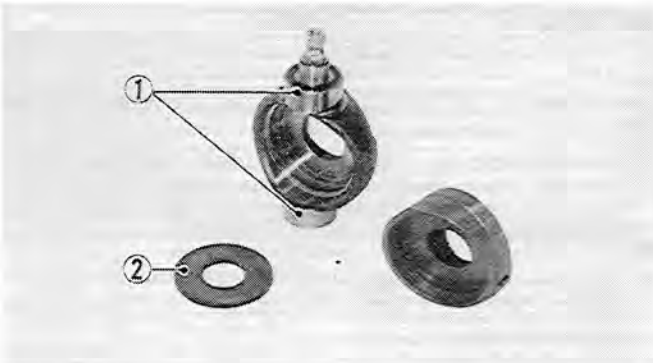

0319P258

(1) Bearing Surface

(2) Thrust Plate

**Swashplate and Thrust Plate**

1. Check the bearing surface of trunnion shaft (1) for scratches and excessive wear.
2. If worn or scored, replace.
3. Check the thrust plate (2) for scratches and excessive wear.
4. If worn or scored, replace.

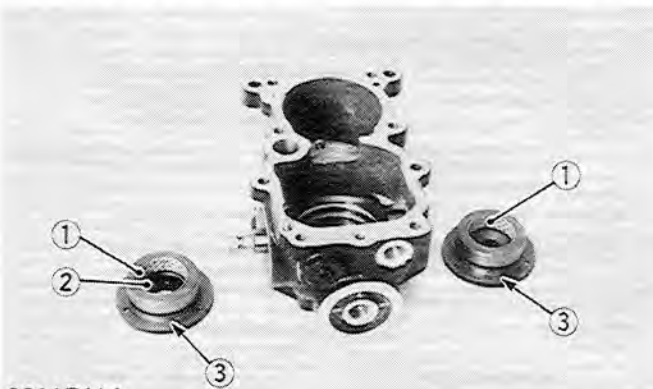

0011P141

(1) Bearing  
(2) Oil Seal

(3) O-ring

**Trunnion Shaft Cover**

1. Check the bearings (1) for scratches and excessive wear.
2. If worn or scored, replace.
3. Check the oil seal (2) and the O-ring (3) for damage.

**NOTE**

- After checking, coat the bearing with hydrostatic transmission oil, and the oil seal lip and the O-ring with grease.
- When replace the oil seal (2), press it in the trunnion shaft cover until it is 1 mm (0.039 in.) below the shoulder and obtain the clearance under it.

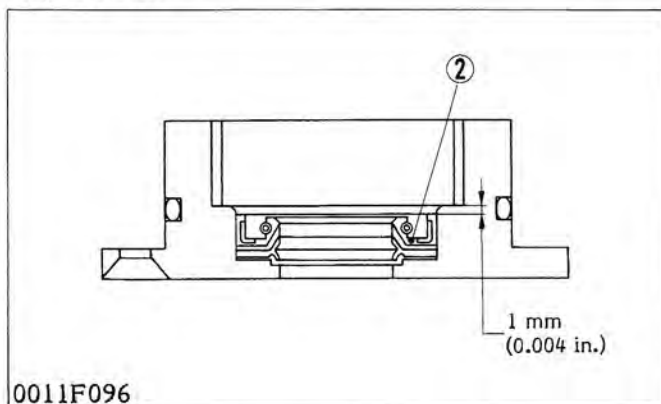

0011F096

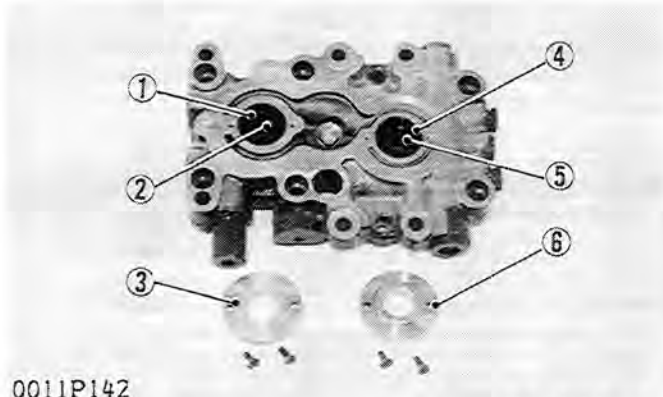

0011P142

- |              |              |
|--------------|--------------|
| (1) Oil Seal | (4) Oil Seal |
| (2) Bearing  | (5) Bearing  |
| (3) Flange 2 | (6) Flange 1 |

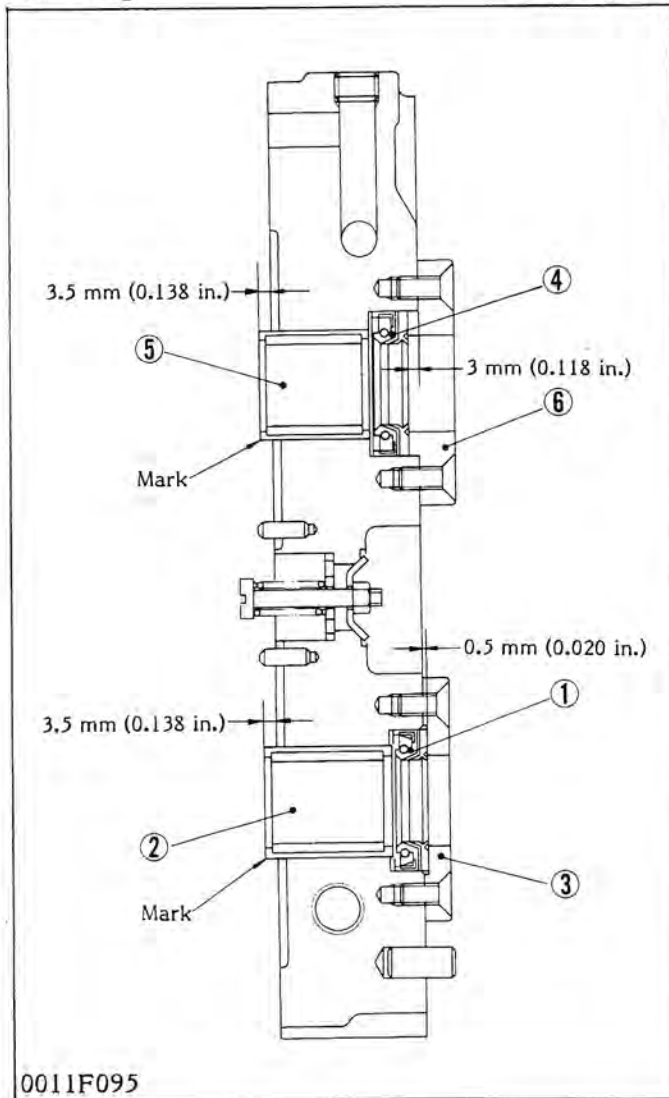

0011F095

**Oil Seal and Bearing**

1. Remove the flanges (3), (6) and check the oil seals (1), (4) for damage.
2. Check the bearings (2), (5) for wear.
3. If the bearings are worn, replace.

■ **NOTE**

- After checking, coat the bearing with hydrostatic transmission oil and the oil seal lip with grease.
- When replacing the bearing, press it in the port block so that its mark faces outside and 3.5 mm (0.138 in.) of it remains above the machined surface.
- When reassembling, always replace the oil seal as follows.
- Press the oil seal (4) in the port block until it is 3 mm (0.118 in.) below the machined surface using the flange 1 (6).
- Press the oil seal (1) in the port block until so that 0.5 mm (0.020 in.) of it remains above the machined surface using the flange 2 (3).

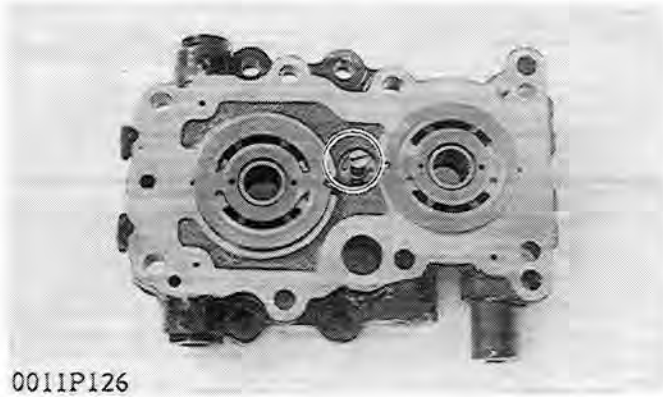

0011P126

**Case Relief Valve**

1. Check the valve and the spring for excessive wear and breakage.
2. If worn or broken, replace.

**NOTE**

- The screw and the nut should be tightened fully, and then 3 to 3.5 mm (0.118 to 0.138 in.) of the thread on the screw will extend from the nut.

**Length of valve spring**

Factory specification.....	25.95 mm
(free)	1.022 in.
(load 29.4 N, 3.00 kgf, 6.62 lbs)	20.0 mm
(load 41.8 N 4.26 kgf, 9.39 lbs)	0.787 in.
	17.5 mm
	0.689 in.

**(Tightening torque)**

Screw and nut.....	1.7 to 2.3 N-m
	0.17 to 0.23 kgf-m
	1.2 to 1.7 ft-lbs

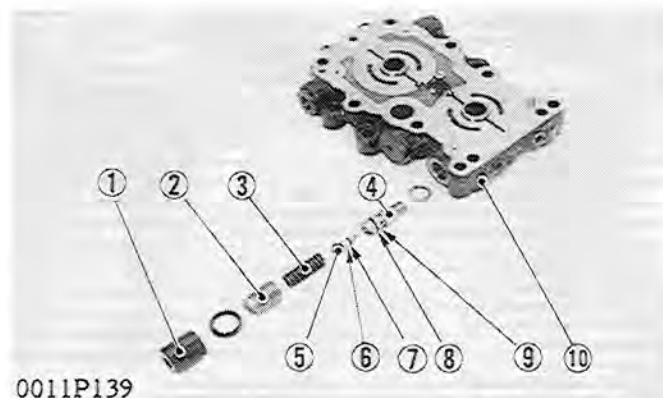

0011P139

- |                  |                 |
|------------------|-----------------|
| (1) Cap Nut      | (6) Backup Ring |
| (2) Set Screw    | (7) O-ring      |
| (3) Spring       | (8) Backup Ring |
| (4) Valve Seat   | (9) O-ring      |
| (5) Poppet Valve | (10) Port Block |

**High Pressure Relief Valve**

1. Remove the cap nut (1).
2. Put an alignment mark across the seat screw (2) and the port block (10) and measure its height from the port block to get the same setting pressure when reassembling.
3. Remove the valve seat (4) using the valve seat driver, which is shown in figure.
4. Check the poppet valve (5) for scratches and damage.
5. Check the valve seat (4) in the port block for damage.
6. Check the O-rings (7), (9) and the backup rings (6), (8) for damage.
7. Check the spring (3) for breakage and wear.
8. If anything unusual, replace the high pressure relief valve complete assembly.

**NOTE**

- When reassembling, replace the O-ring and bonded seal.
- When the setting height of the seat screw (2) is not known, tighten it temporarily and adjust after reassembling the tractor.
- After reassembling the tractor, check the setting pressure and adjust by turning the set screw (2).

**Length of valve spring**

Factory specification.....	40.00 mm
(free)	1.575 in.
(load 612 N, 62.4 kgf, 138 lbs)	34.0mm
(load 765 N 78.0 kgf, 172 lbs)	1.339 in.
	32.5 mm
	1.280 in.

**(Tightening torque)**

Cap Nut.....	59 to 69 N-m
	6.0 to 7.0 kgf-m
	43 to 51 ft-lbs
Valve Seat.....	24 to 29 N-m
	2.4 to 3.0 kgf-m
	17 to 22 ft-lbs

"Valve-seat Driver"

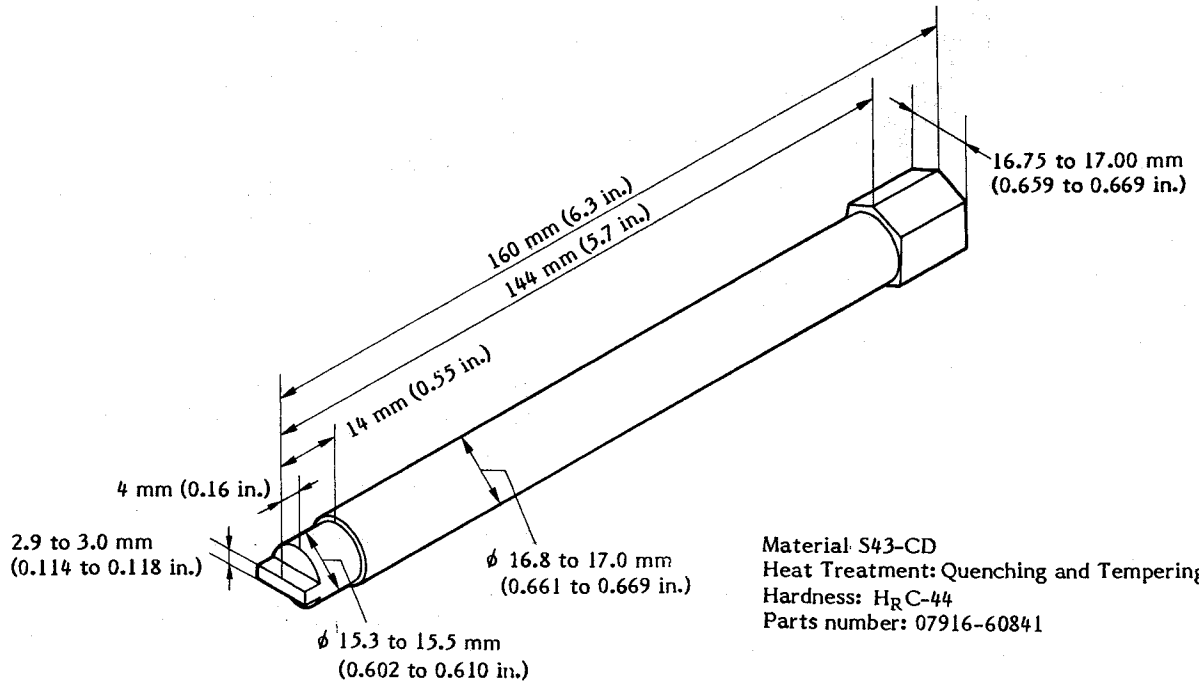

0011F094

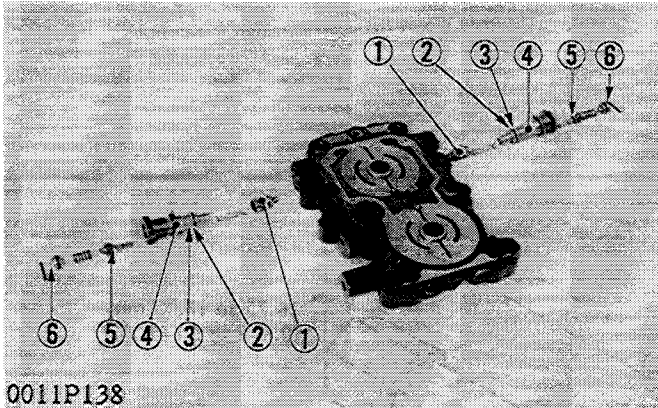

0011P138

- (1) Check Valve
- (2) O-ring
- (3) Backup Ring
- (4) Valve Body
- (5) Neutral Valve
- (6) O-ring

**Neutral and Check Valves**

1. Remove the valve assembly and disassemble it.
2. Check the check valve (1) and the neutral valve (5) for their free movement on or in the valve body (4).
3. If the valve surface is scored, replace.
4. Check the holes of the valve body (4) and the neutral valve (5) for clogging.
5. If clogged, open hole with compressed air.
6. Check the O-rings (2), (6) and the backup ring (3) for scratches and damage.
7. Check the springs for breakage and wear.
8. If anything unusual, replace.

■ **NOTE**

- When reassembling, replace the O-rings and the backup rings.

Length of valve spring (1) (neutral valve)

Factory specification.....	19.71 mm
(free)	0.7760 in.
(load 27 N, 2.7 kgf, 6.0 lbs)	15 mm
	0.591 in.
(load 49.0 N 5.0 kgf, 11.0 lbs)	11 mm
	0.43 in.

Length of valve spring (2) (neutral valve)

Factory specification.....	29.7 mm
(free)	1.1691 in.
(load 17 N, 1.7 kgf, 3.7 lbs)	15 mm
	0.591 in.
(load 21.18 N 2.16 kgf, 4.76 lbs)	11 mm
	0.43 in.

Length of valve spring (check valve)

Factory specification.....	26.91 mm
(free)	1.0594 in.
(load 3.128 N, 0.319 kgf, 0.703 lbs)	19.5 mm
	0.768 in.
(load 4.511 N 0.460 kgf, 1.014 lbs)	16.2 mm
	0.638 in.

**(Tightening torque)**

Valve body to case.....	34 to 39 N-m
	3.5 to 4.0 kgf-m
	25 to 29 ft-lbs

**Charge Relief Valve**

1. Remove the internal circlip (5) and draw out the spring holder (4).
2. Check the spring (3) for breakage and wear.
3. Check the O-ring (1), (2) for damage.
4. If anything unusual, replace.

■ **NOTE**

- Install the internal circlip with its sharp edge facing outside.

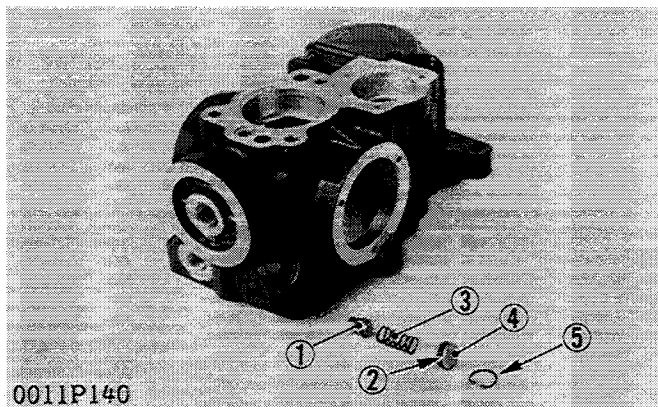

0011P140

- (1) O-ring
- (2) O-ring
- (3) Spring
- (4) Spring Holder
- (5) Circlip



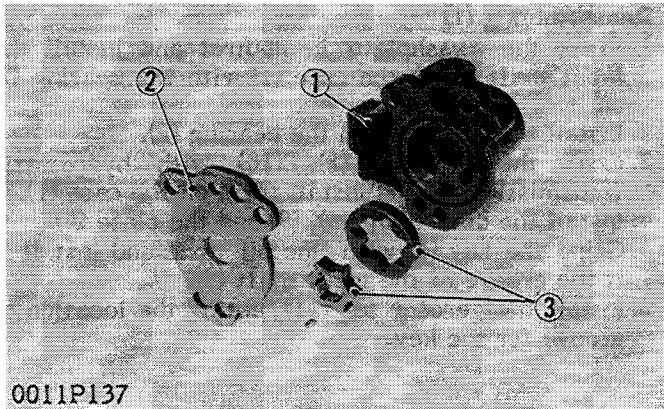

0011P137

- (1) Charge Pump Case
- (2) Plate
- (3) Gerotor Set
- (4) Straight Edge

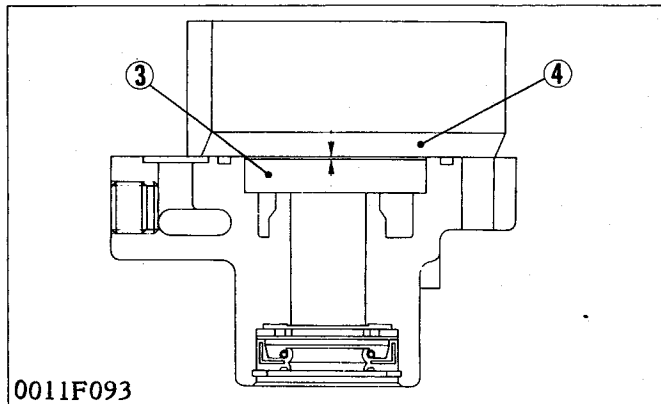

0011F093

**Charge Pump**

1. Check the charge pump case (1), the plate (2) and the gerotor set (3) for scratches and wear.
2. If scratched or worn, replace the charge pump complete assembly.
3. Measure the side clearance referring to the figure.
4. If the clearance exceeds the factory specification, replace the charge pump complete assembly.

**NOTE**

- When reassembling, replace the O-rings and the oil seals, and grind the surface of the plate (2) and the charge pump case (1) with finest oil stone.

**Side clearance**

Factory specification..... 0.030 to 0.060 mm  
0.00118 to 0.0236 in.

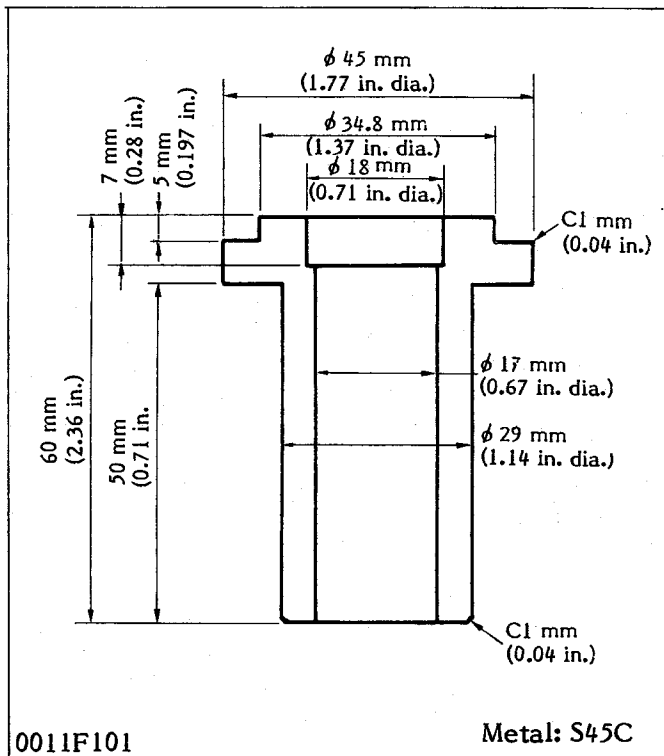

0011F101

Metal: S45C

**Special Tool A for Pressing Oil Seal**

1. Make the special tools shown in figure and reassemble the charge pump according to following directions.

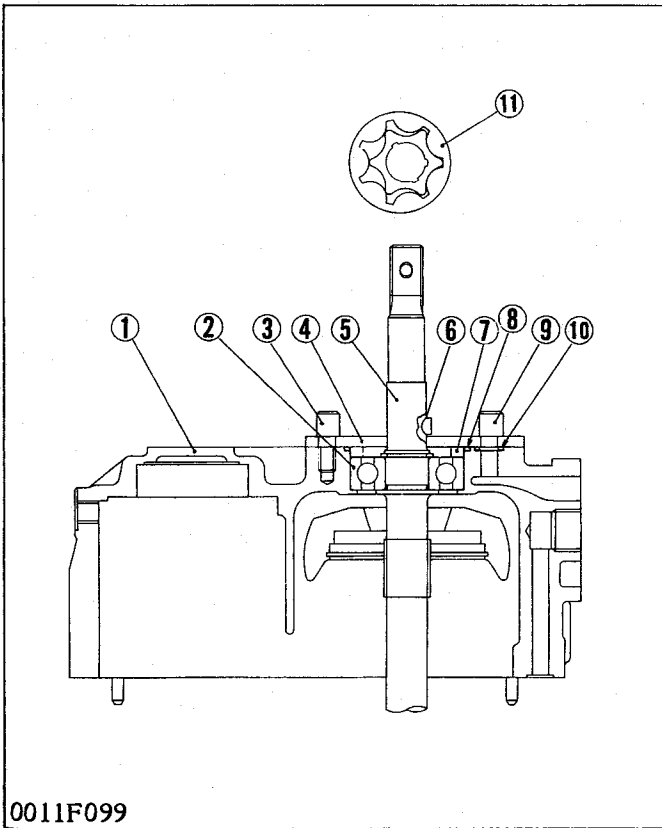

0011F099

- |                 |                  |
|-----------------|------------------|
| (1) Case        | (7) Collar       |
| (2) Bearing     | (8) O-ring       |
| (3) Dowel Pin   | (9) Dowel Pin    |
| (4) Plate       | (10) O-ring      |
| (5) Input Shaft | (11) Gerotor Set |
| (6) Key         |                  |

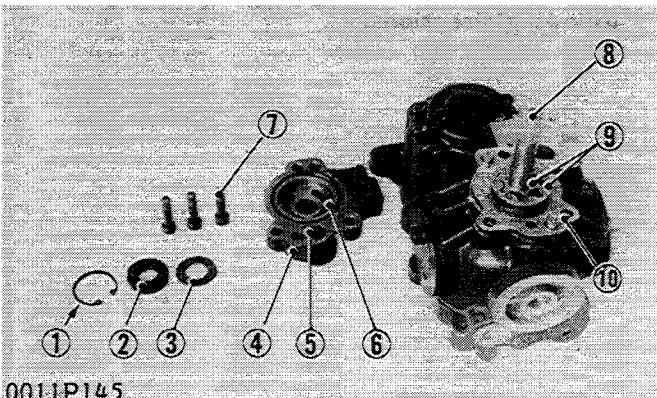

0011P145

- |                      |                 |
|----------------------|-----------------|
| (1) Circlip          | (6) O-ring      |
| (2) Oil Seal         | (7) Screw       |
| (3) Plate            | (8) Input Shaft |
| (4) Charge Pump Case | (9) Gerotor Set |
| (5) O-ring           | (10) Plate      |

**Reassembling (1)**

1. Press the swashplate in neutral and install the input shaft (5) to the case (1) with the bearing (2) on it.
2. Install the collar (7) on the bearing (2).
3. Coat the O-rings (8), (10) with hydrostatic transmission oil and install them on the case (1).
4. Install the dowel pins (3), (9) and the plate (4).
5. Grind the key (6) with fine oil stone and install in it the groove of the input shaft (5).
6. Install the gerotor set (11), noting the location of groove for the key.

**Reassembling (2)**

1. Coat the O-rings (5), (6) with hydrostatic transmission oil and install them on the charge pump case (4).
2. Install the charge pump case (4) on the plate (10) and the gerotor set (9), and screw the screws (7) lightly.
3. Press the plate (3) in the charge pump case (4).
4. Cover the splines and the shoulder of the input shaft (8) with thin tape.
5. Press the oil seal (2) in the charge pump case using the special tool (A), until it is 4 mm (0.157 in.) below the machined surface.
6. Install the internal circlip (1) with its sharp edge facing outside.
7. Tighten the screws (7).

**(Tightening torque)**

Charge pump case to case.. 11 to 14 N-m  
 1.1 to 1.4 kgf-m  
 8.0 to 10.1 ft-lbs

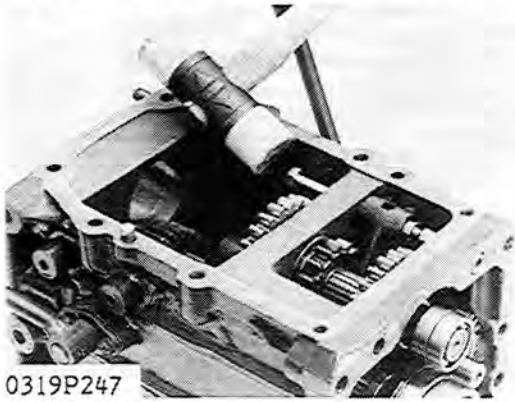
**[3] MECHANICAL TRANSMISSION**

0319P247

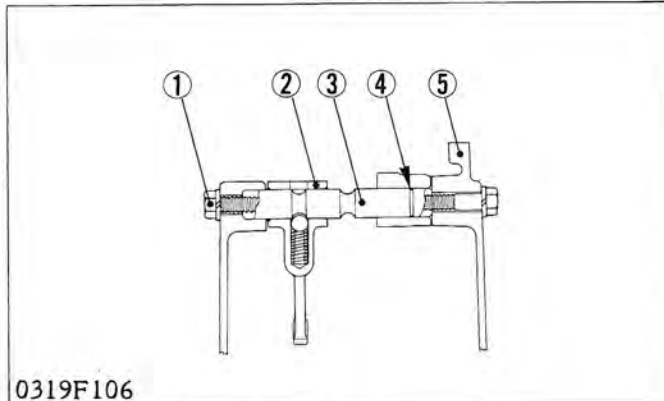

0319F106

- |                           |                            |
|---------------------------|----------------------------|
| (1) Fork Shaft Lock Screw | (4) Groove                 |
| (2) Shift Fork            | (5) Differential Gear Case |
| (3) Fork Shaft            |                            |

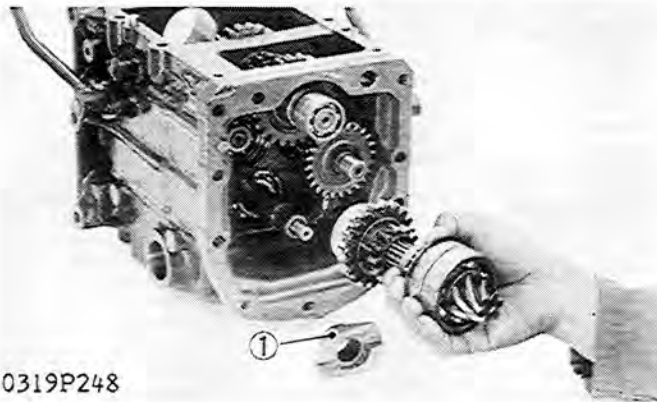

0319P248

- (1) Drum

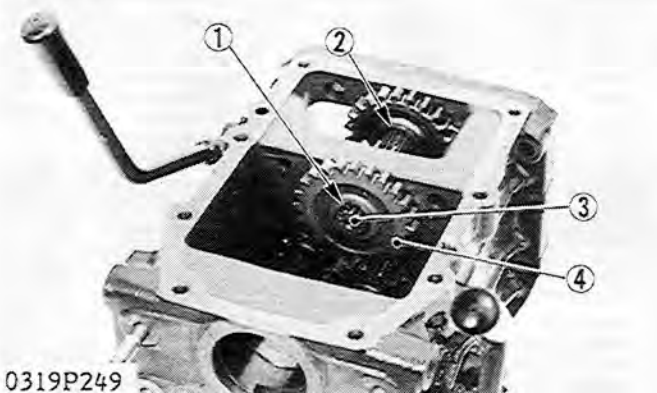

0319P249

- |             |               |
|-------------|---------------|
| (1) Circlip | (3) 4th Shaft |
| (2) Circlip | (4) 24T Gear  |

**DISASSEMBLY AND ASSEMBLY****Fork Shaft and Shift Fork**

1. Remove the fork shaft lock screw (1).
2. Screw M8 screw (pitch 1.25 x 70 mm long, pitch 1.25 x 2.76 in. long) into the fork shaft (3), and tap out it to the rear.
3. Remove the shift fork (2).

**(When reassembling)**

- Install the fork shaft with the groove (4) facing the differential gear case (5).

**Spiral Bevel Pinion Shaft**

1. Remove the one-way clutch drum (1).
2. Remove the spiral bevel pinion with gears and bearings on it.

**4th Shaft**

1. Remove the external circlip (1) and shift the external circlip (2) forward.
2. Tapping out the 4th shaft (3) rearward, remove the 24T gear (4).
3. Take out the 4th shaft with the gears and the bearings on it.

**Front Wheel Drive Shaft**

1. Remove the 24T gear (1).
2. Remove internal circlip (2).
3. Draw out the front wheel drive shaft (3).

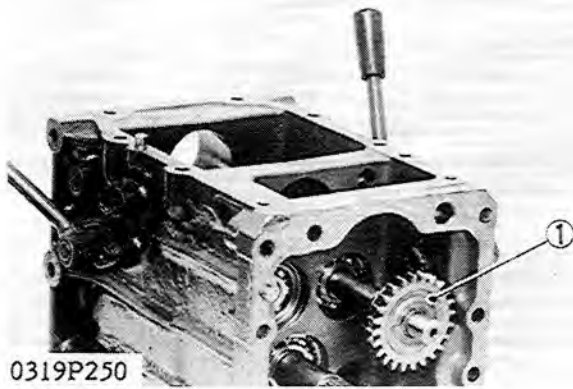

0319P250  
(1) 24T Gear

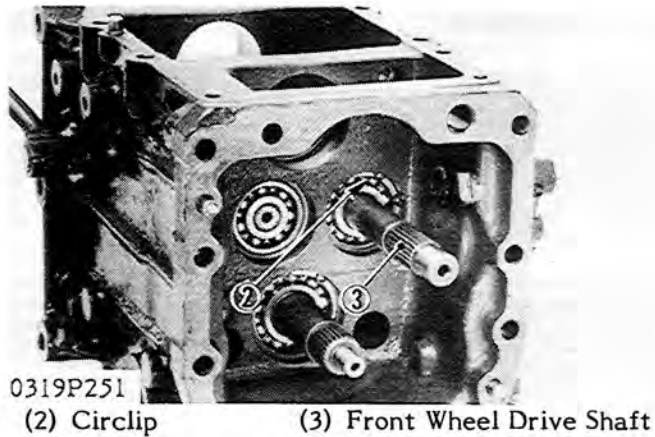

0319P251  
(2) Circlip (3) Front Wheel Drive Shaft

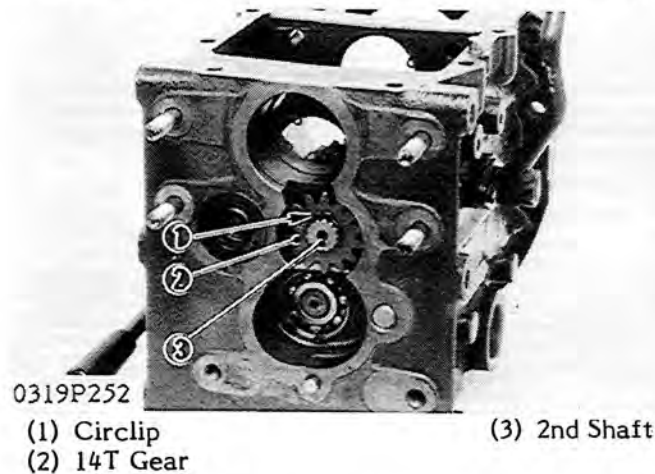

0319P252  
(1) Circlip (2) 14T Gear (3) 2nd Shaft

**2nd Shaft and 29T-14T-18T Gear**

1. Remove the external circlip (1).
2. Remove the 14T gear (2).
3. Tap out the 2nd shaft (3) rearward.
4. Take out the 29T-14T-18T gear.

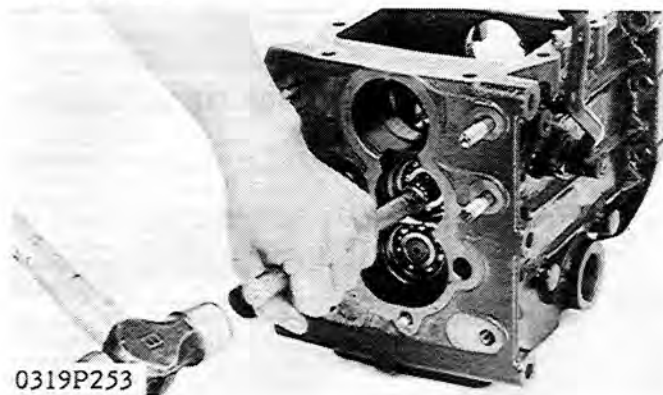

0319P253

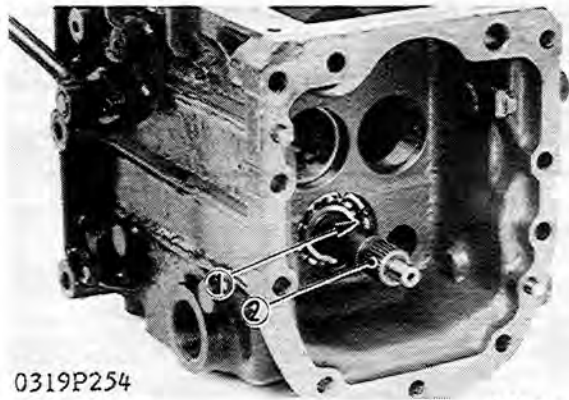

0319P254

(1) Circlip

(2) 3rd Shaft

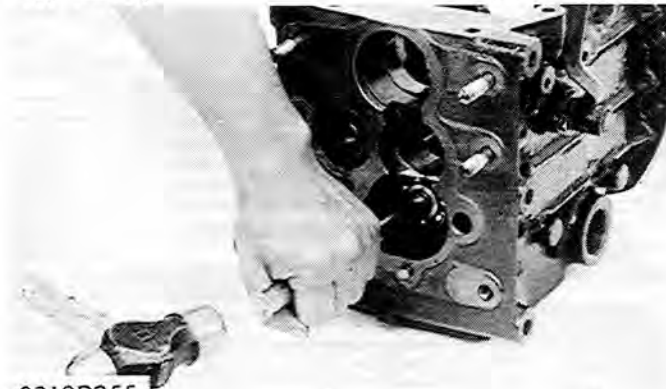

0319P255

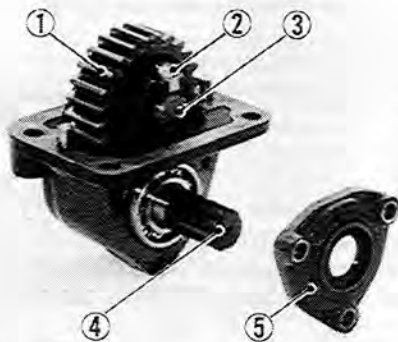

0303P046

(1) 24T Gear  
(2) Screw  
(3) Shaft

(4) 11T Gear Shaft  
(5) Cover

**3rd Shaft and 21T-21T-17T Gear**

1. Remove the internal circlip (1).
2. Tap out the 3rd shaft (2) rearward.
3. Take out the 21T-21T-17T gear.

**Mid-PTO**

1. Separate the mid-PTO case from the transmission case.
2. Remove the mid-PTO case cover (5).
3. Remove the screw (2) and pull out the mid-PTO counter shaft (3) and remove the 24T gear (1).
4. Draw out the 11T gear shaft (4) with the bearing on it.

**(Tightening torque)**

Screw (2).....	14 to 20 N-m 1.4 to 2.0 kgf-m 10 to 14 ft-lbs
Mid-PTO case cover.....	14 to 20 N-m 1.4 to 2.0 kgf-m 10 to 14 ft-lbs
Mid-PTO case.....	48 to 56 N-m 4.9 to 5.7 kgf-m 35 to 41 ft-lbs

**NOTE**

- Mid-PTO for B6200HSE (above S/N 11354), B7200HSE (above S/N 11636), B6200HSD (above S/N 52424) and B7200HSD (above S/N 56970) was modified as shown in the left figure.

**Mid-PTO**

1. Separate the mid-PTO case from the transmission case.
2. After tapping the spring pin (2) into the shaft (3), remove the shaft (3) and the 24T gear (1).
3. Remove the oil seal (6) and the external snap ring (5).
4. Draw out the 11T gear shaft (4) with the bearing on it.

**(Tightening torque)**

Plug.....	32.5 to 36.2 N-m 4.5 to 5.0 kgf-m 44 to 49 ft-lbs
Mid-PTO case.....	48.0 to 55.9 N-m 4.9 to 5.7 kgf-m 35 to 41 ft-lbs

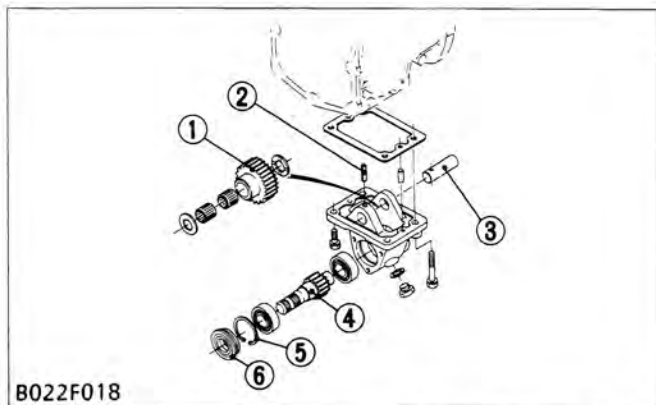

B022F018

(1) 24T Gear  
(2) Spring Pin  
(3) Shaft

(4) 11T Gear Shaft  
(5) Snap Ring  
(6) Oil Seal

[4] DIFFERENTIAL GEAR CASE

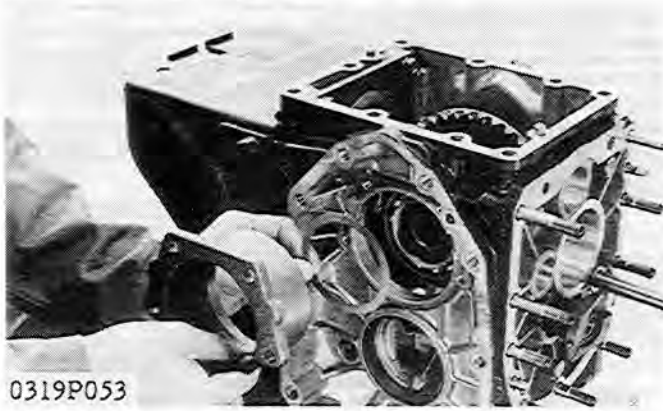

0319P053

DISASSEMBLY AND ASSEMBLY

Differential Assembly

1. Remove the left and right differential bearing holders (19), (9).
2. Take out the differential assembly from the differential gear case.

(When reassembling)

- Install the differential assembly, noting the number of differential side shims (10), (18).

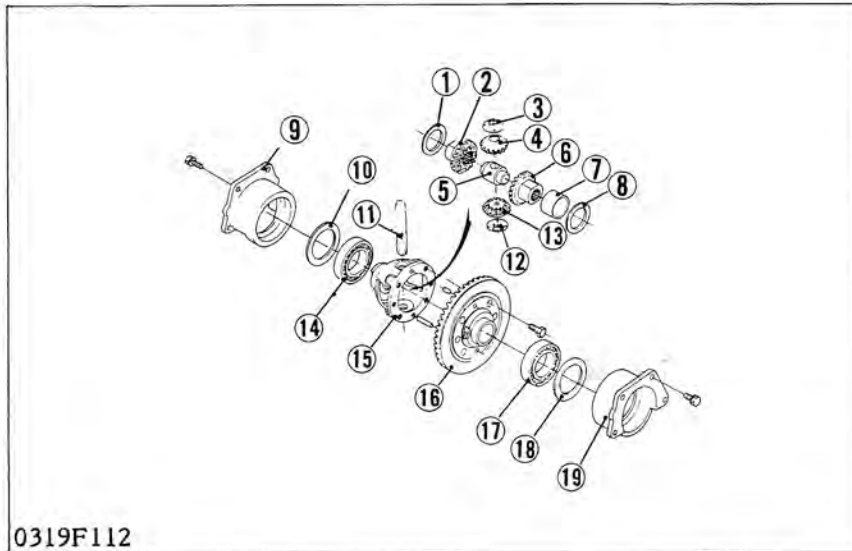

0319F112

- (1) Shim
- (2) Differential Side Gear
- (3) Differential Pinion Collar
- (4) Differential Pinion
- (5) Thrust Collar
- (6) Differential Side Gear
- (7) Ring Gear Bushing
- (8) Shim
- (9) Differential Bearing Holder (RH)
- (10) Differential Side Shim
- (11) Differential Pinion Shaft
- (12) Differential Pinion Collar
- (13) Differential Pinion
- (14) Bearing
- (15) Differential Case
- (16) Ring Gear
- (17) Bearing
- (18) Differential Side Shim
- (19) Differential Bearing Holder (LH)

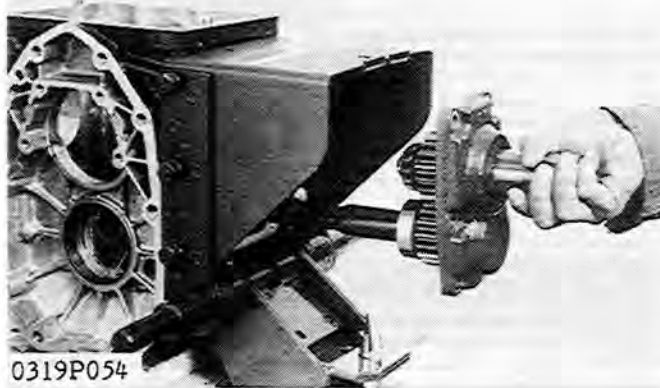

0319P054

5th Shaft

1. Remove the external snap ring (1), and remove the drum (2) and spring (3).
2. Remove the rear cover mounting screws.
3. Remove the 5th shaft (5) with the PTO shaft.

(Tightening torque)

Rear cover mounting..... 39.2 to 64.7 N-m  
 screw 4.0 to 6.6 kgf-m  
 28.9 to 47.7 ft-lbs

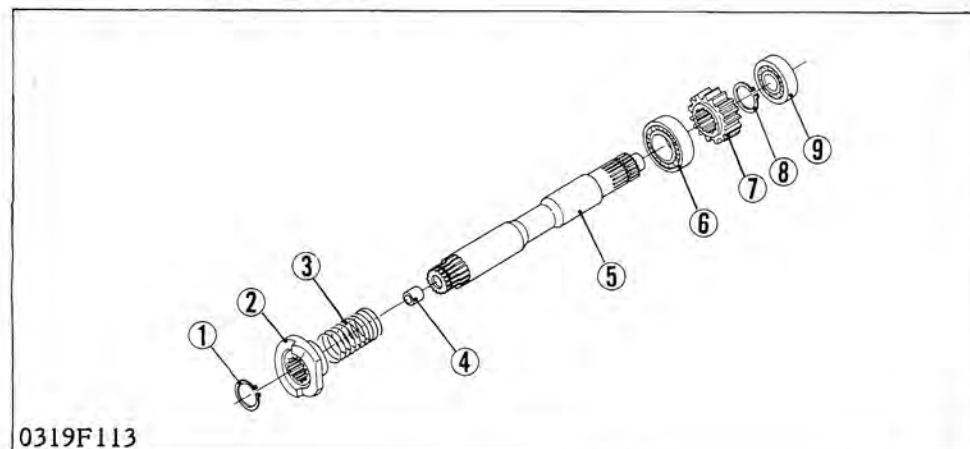

0319F113

- (1) External Snap Ring
- (2) Drum
- (3) Spring
- (4) Bushing
- (5) 5th Shaft
- (6) Bearing
- (7) 17T Gear
- (8) External Snap Ring
- (9) Bearing

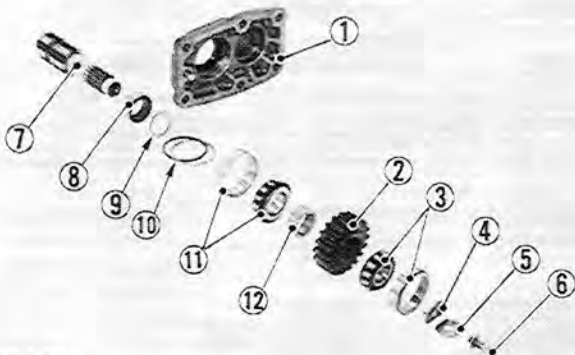

0319P055

- |                          |                           |
|--------------------------|---------------------------|
| (1) Rear Cover           | (7) PTO Shaft             |
| (2) 18T Gear             | (8) Bushing               |
| (3) Taper Roller Bearing | (9) PTO Collar            |
| (4) Washer               | (10) PTO Shim             |
| (5) Lock Washer          | (11) Taper Roller Bearing |
| (6) Screw                | (12) PTO Collar           |

**PTO Shaft**

1. Flatten the lock washer (5).
2. Remove the screw (6), plain washer, lock washer (5), washer (4) and straight pin.
3. Tap out the PTO shaft (7) to the rear.

**(When reassembling)**

- Replace the lock washer with a new one, and be sure to adjust the turning torque of PTO shaft. (See page S.2-10 in B5200·B6200·B7200 WSM)
- Lock the screw with the lock washer after adjusting the turning torque.

**(Tightening torque)**

Screw.....	18.6 to 32.4 N·m
	1.9 to 3.3 kgf·m
	13.7 to 23.9 ft·lbs

**[5] TRANSMISSION (TRANSMISSION CASE, DIFFERENTIAL GEAR CASE)**

**SERVICING**

**Checking Bearing**

1. Hold the inner race, and push and pull the outer race in all directions to check for wear and roughness.
2. Apply transmission oil to the bearing, and hold the inner race. Then, turn the outer race to check rotation.
3. If there is any defect, replace.

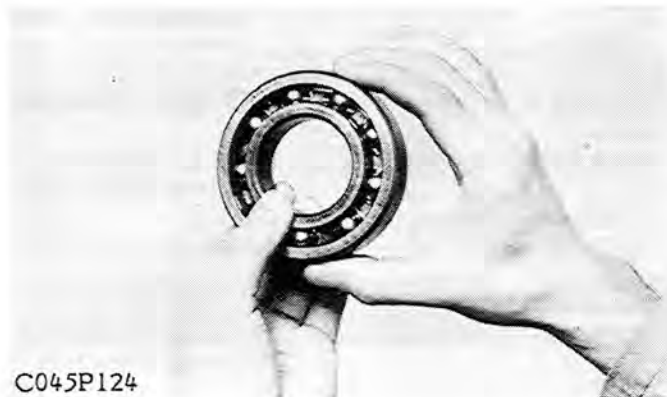

C045P124

**Backlash between Gear and Spline**

1. Secure the shaft in a vise.
2. Set a dial indicator (lever type).
3. Move the gear by hand for measurement.
4. If the measurement exceeds the allowable limit, replace it.

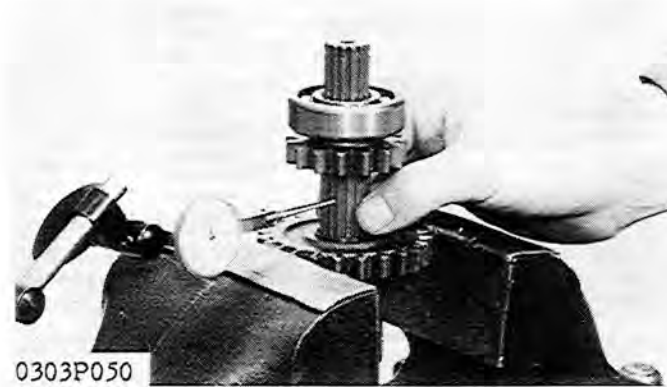

0303P050

**Backlash between gear and spline**

Factory specification.....	0.03 to 0.08 mm
	0.002 to 0.003 in.
Allowable limit.....	0.20 mm
	0.008 in.

**Gear Backlash**

1. Set a dial indicator (lever type) with its finger on the tooth surface.
2. Move the gear to measure the backlash, while holding the mating gear.
3. If the measurement exceeds the allowable limit, replace.



0319P056

**Gear backlash**

Factory specification.....	0.10 to 0.20 mm
	0.004 to 0.008 in.
Allowable limit.....	0.4 mm
	0.006 in.



0303P052



0303P053

### Clearance between Shift Fork and Shift Gear Groove

1. Place the shift fork in the shift gear groove and measure the clearance with a feeler gage.
2. If the clearance exceeds the allowable limit, replace.

Clearance between shift fork and shift gear groove	
Factory specification.....	0.10 to 0.30 mm 0.004 to 0.012 in.
Allowable limit.....	0.5 mm 0.020 in.

### Clearance between 29T-14T-18T Gear and 2nd Shaft

1. Measure the 29T-14T-18T gear I.D. with an inside micrometer, and then 2nd shaft O.D. with an outside micrometer.
2. Measure the O.D. of two needles in the needle bearing with an outside micrometer.
3. Clearance is the difference between the gear I.D. and the sum of shaft O.D. and two needle O.D.
4. If the clearance exceeds the allowable limit, replace.

Clearance between 29T-14T-18T gear and reverse shaft	
Factory specification.....	0.007 to 0.053 mm 0.0003 to 0.0021 in.
Allowable limit.....	0.1 mm 0.0039 in.

2nd shaft O.D.	
Factory specification.....	21.987 to 22.000 mm 0.8656 to 0.8661 in.

29T-14T-18T gear I.D.	
Factory specification.....	28.007 to 28.028 mm 1.1026 to 1.1035 in.

Needle O.D.	
Factory specification.....	29.94 to 30.00 mm 0.1179 to 0.1181 in.

Clearance between 17T, 21T gear and 3rd shaft	
Factory specification	0.007 to 0.047 mm 0.0003 to 0.00185 in.
Allowable limit	0.1 mm 0.0039 in.

3rd shaft O.D.	
Factory specification.....	24.987 to 25.000 mm 0.9837 to 0.9843 in.

21T, 17T gear I.D.	
Factory specification.....	29.007 to 29.028 mm 1.1420 to 1.1428 in.

Needle O.D.	
Factory specification.....	1.997 to 2.000 mm 0.0786 to 0.0787 in.





0319P059

**Initial Turning Torque of PTO Shaft**

1. Tighten the screw (10) to the specified torque (18.6 to 32.4 N-m, 1.9 to 3.3 kgf-m, 13.7 to 23.9 ft-lbs).
2. Install the PTO shaft to the rear cover, and install it to the differential gear case.
3. Screw the screw (M 10 x Pitch 1.25) in the PTO shaft (9), and set a torque wrench to it.
4. Turn the PTO shaft with a torque wrench to measure the initial turning torque.
5. If the initial turning torque is not within the factory specifications, adjust the shim (15).

**Initial turning torque**

Factory specification.....0.49 to 1.47 N-m  
 0.05 to 0.15 kgf-m  
 0.36 to 1.08 ft-lbs

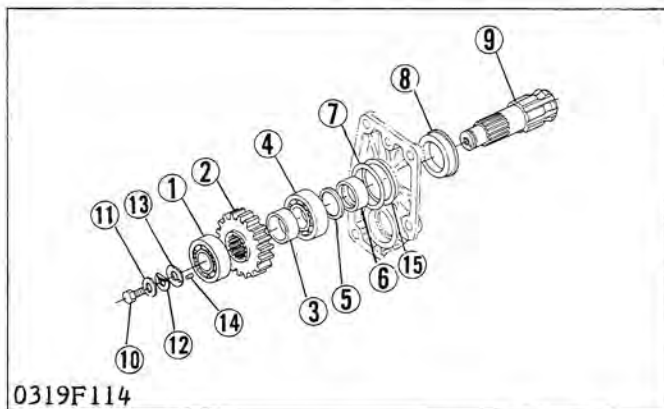

0319F114

- |                          |                   |
|--------------------------|-------------------|
| (1) Taper Roller Bearing | (9) PTO Shaft     |
| (2) 18T Gear             | (10) Screw        |
| (3) PTO Collar           | (11) Plain Washer |
| (4) Taper Roller Bearing | (12) Lock Washer  |
| (5) PTO Collar           | (13) Washer       |
| (6) Bushing              | (14) Straight Pin |
| (7) PTO Bearing Collar   | (15) Shim         |
| (8) Oil Seal             |                   |

**(Reference)**

- Thickness of shim: 0.3 mm (0.012 in.)  
 0.4 mm (0.016 in.)  
 0.5 mm (0.020 in.)

**■ NOTE**

- Lock the screw (10) with the lock washer (12) after adjusting the turning torque.

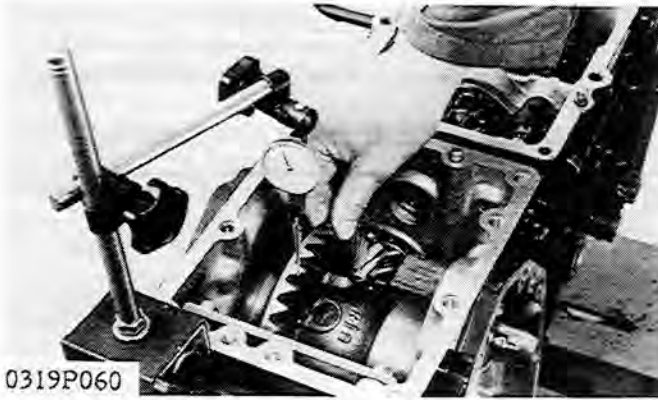

0319P060

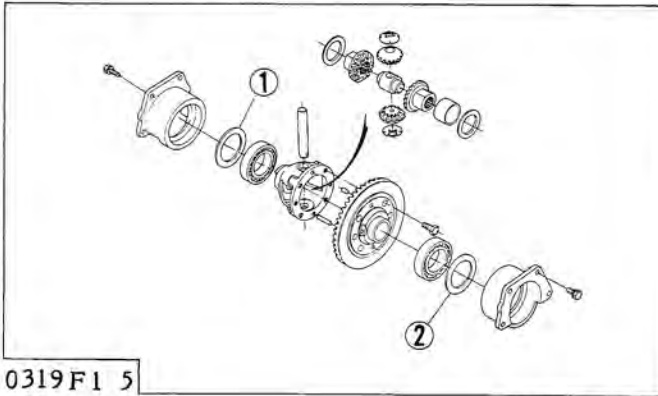

0319F1 5

(1) Shim

(2) Shim

**Backlash between Ring Gear and Spiral Bevel Pinion Shaft**

1. Set a dial indicator (lever type) on the ring gear.
2. Measure the backlash by fixing the spiral bevel pinion shaft and moving the ring gear by hand.
3. When the backlash is too small, decrease the number of shims (2) in the side of the ring gear, and insert the removed shims in the opposite side. When the backlash is too large, decrease the number of shims (1) in the side of the differential case, and insert the removed shims in the opposite side.
4. Adjust the backlash properly by repeating the above procedure.

**Backlash between ring gear and spiral bevel pinion shaft**

Factory specification.....	0.1 to 0.2 mm 0.004 to 0.008 in.
Allowable limit.....	0.4 mm 0.016 in.

**(Reference)**

- Thickness of differential side shims (1): 0.2 mm (0.008 in.)  
0.3 mm (0.012 in.)  
0.5 mm (0.020 in.)
- Thickness of differential side shims (2): 0.2 mm (0.008 in.)  
0.3 mm (0.012 in.)  
0.5 mm (0.020 in.)

## TO THE READER

In this section, the altered points of New HYDROSTATIC TRANSMISSION from the previous HST are explained separately in two items, "Mechanism" and "Servicing".

The serial number of tractors, new HST has been affected, is as follows.

B6200HST (2WD)	above 20001
B6200HST (4WD)	above 60001
B7200HST (2WD)	above 20001
B7200HST (4WD)	above 60001

As for the items which are not explained in this section, refer to Workshop Manual for B5200-B6200-B7200-B6200HST-B7200HST.

All information, illustrations and specifications contained in this manual are based on the latest production information available at the time of publication.

The right is reserved to make changes in all information at any time without notice.

October '89

# CONTENTS

## MECHANISM

<b>2</b> TRANSMISSION .....	BM.2-1
[1] HYDROSTATIC TRANSMISSION .....	BM.2-1

## SERVICING

<b>2</b> TRANSMISSION .....	BS.2-1
SERVICING SPECIFICATIONS .....	BS.2-1
TIGHTENING TORQUES .....	BS.2-2
CHECKING, DISASSEMBLING AND SERVICING .....	BS.2-3
[1] SPEED SET DEVICE .....	BS.2-3
DISASSEMBLING AND ASSEMBLING .....	BS.2-3
[2] HYDROSTATIC TRANSMISSION .....	BS.2-4
CHECKING AND ADJUSTING .....	BS.2-4
DISASSEMBLING AND ASSEMBLING .....	BS.2-8
SERVICING .....	BS.2-12

# 2 TRANSMISSION

## [1] HYDROSTATIC TRANSMISSION

■ NOTE

- Tractor serial number B6200HST 2WD above 20001  
 B6200HST 4WD above 60001  
 B7200HST 2WD above 20001  
 B7200HST 4WD above 60001

(1) Structure

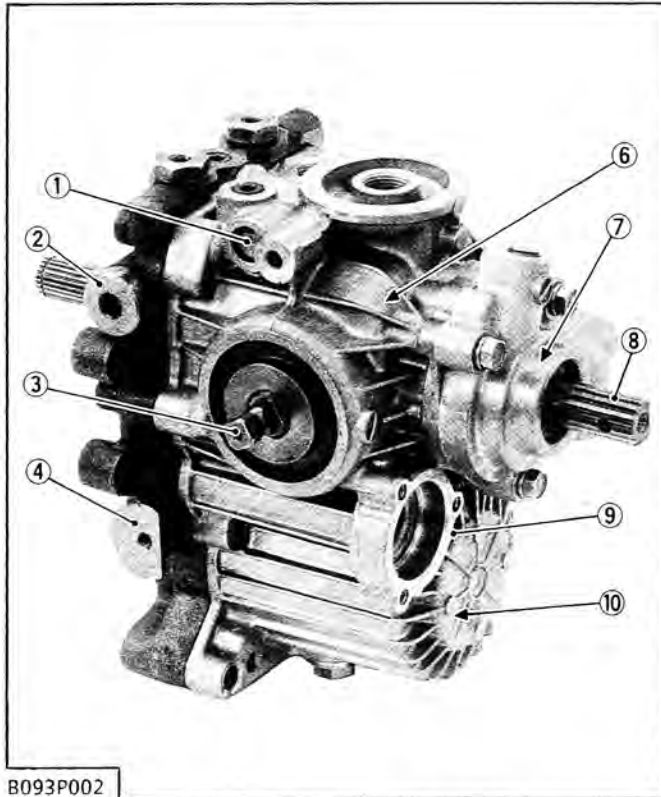

B093P002

- (1) Charge Relief Valve
- (2) Check and High Pressure Relief Valve
- (3) Trunnion Shaft
- (4) Port Block
- (5) Neutral Valve

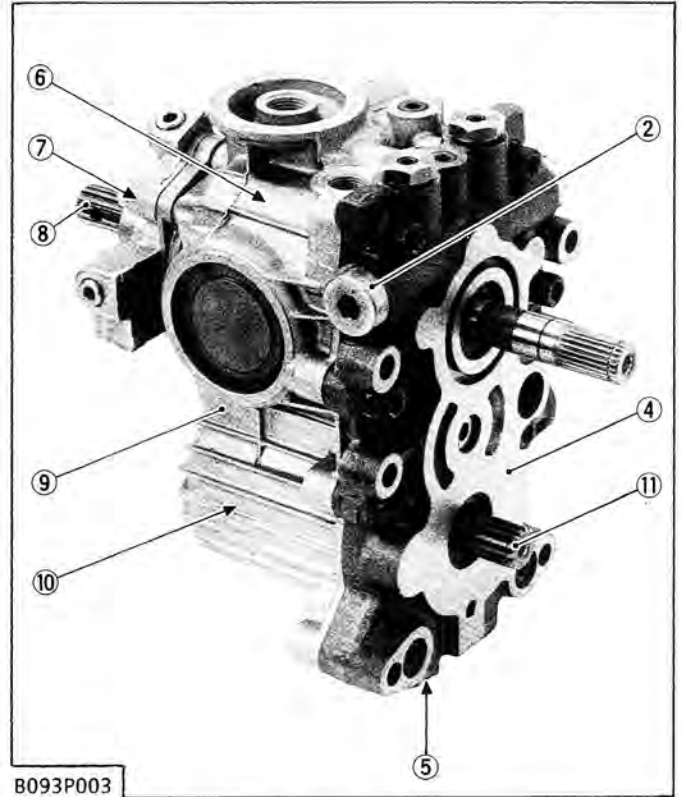

B093P003

- (6) Variable Displacement Piston Pump
- (7) Charge Pump
- (8) Input Shaft
- (9) Case
- (10) Fixed Displacement Piston Motor
- (11) Output Shaft

Hydrostatic transmission is composed of a variable displacement piston pump, fixed displacement piston motor, charge pump and valve system.

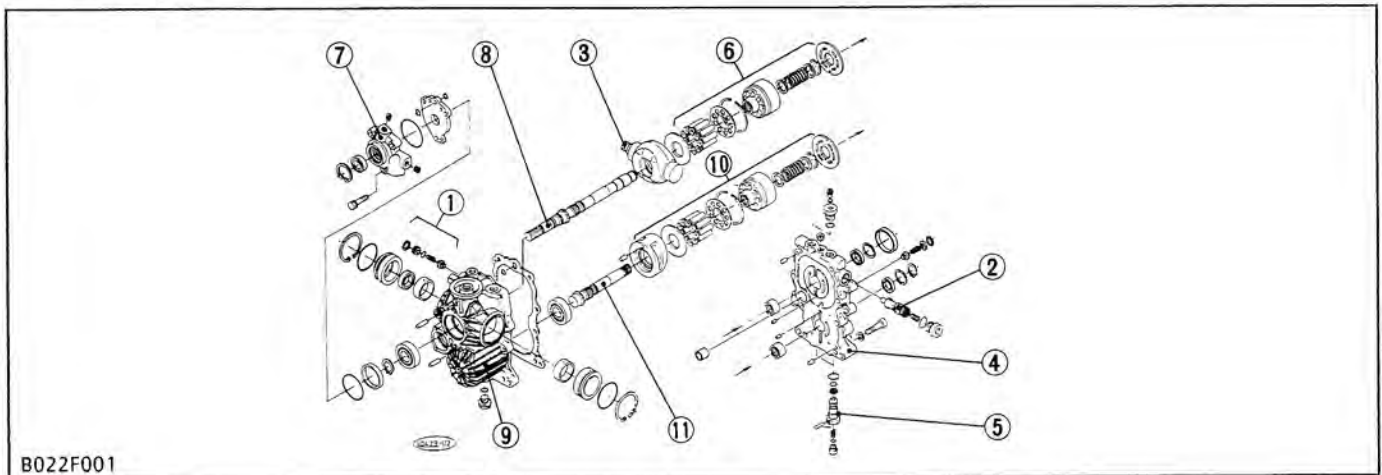

B022F001

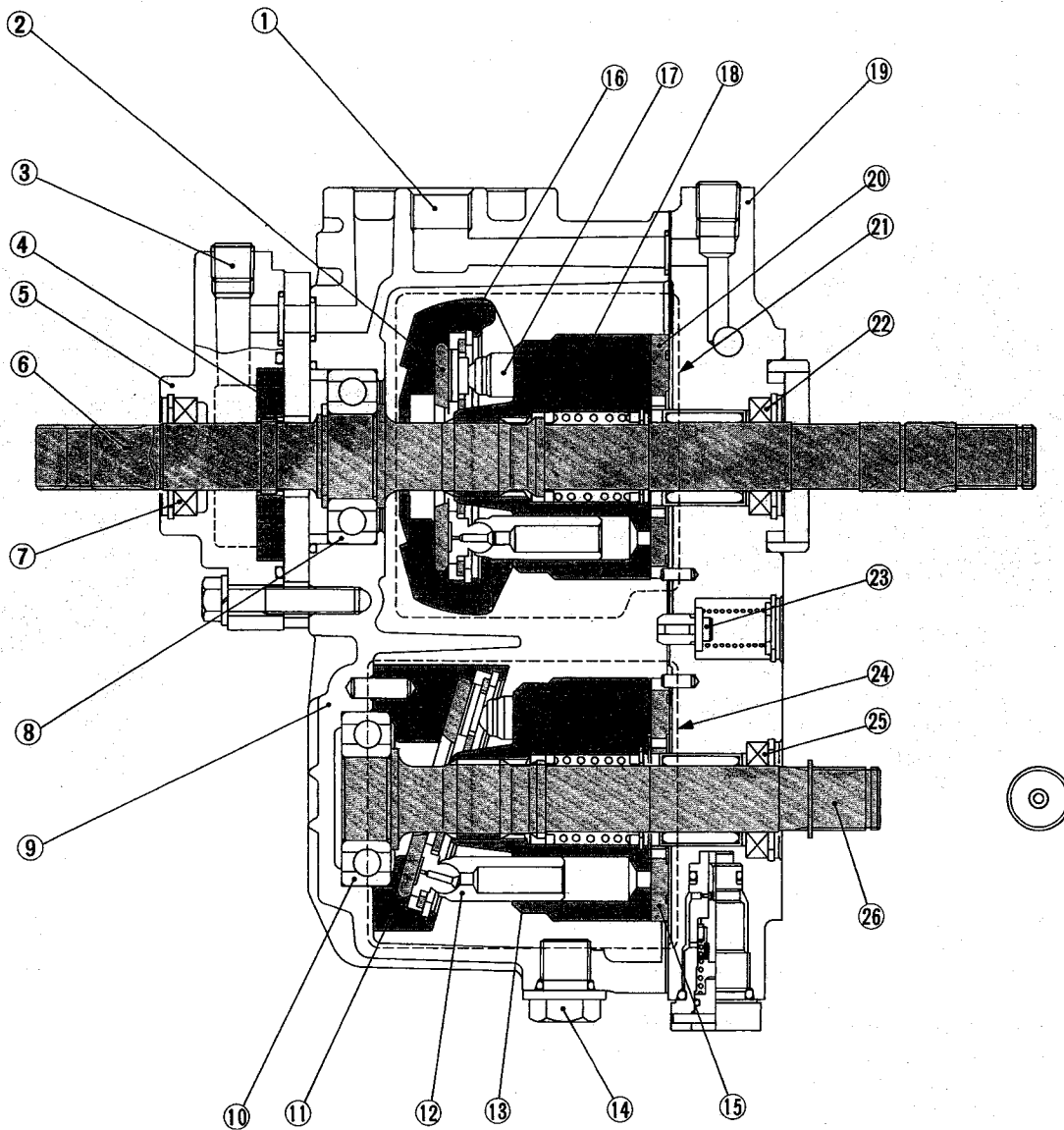

B093F006

- |                             |                       |  |                                      |
|-----------------------------|-----------------------|--|--------------------------------------|
| (1) Oil Outlet              | (8) Ball Bearing      | (16) Variable Swashplate               | (22) Oil Seal                        |
| (2) Thrust Plate            | (9) Case              | (17) Piston                            | (23) Case Relief Valve               |
| (3) P3 Port                 | (10) Ball Bearing     | (18) Cylinder Block                    | (24) Fixed Displacement Piston Motor |
| (4) Trochoid Rotor Assembly | (11) Fixed Swashplate | (19) Port Block                        | (25) Oil Seal                        |
| (5) Charge Pump Case        | (12) Piston           | (20) Valve Plate                       | (26) Output Shaft                    |
| (6) Input Shaft             | (13) Cylinder Block   | (21) Variable Displacement Piston Pump |                                      |
| (7) Oil Seal                | (14) Drain Plug       |  |                                      |
|                             | (15) Valve Plate      |  |                                      |

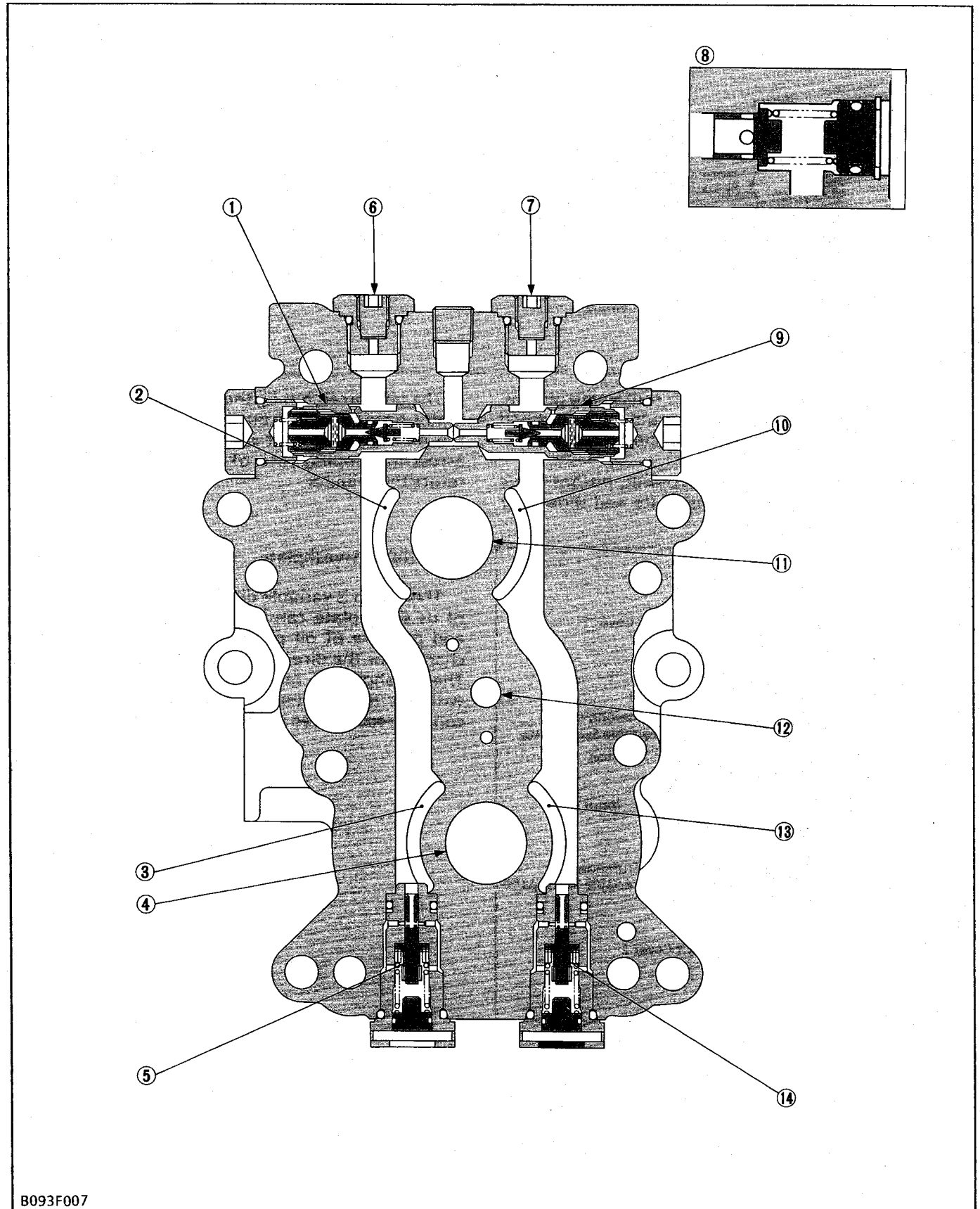

B093F007

- |  |                             |  |                              |
|--|-----------------------------|--|------------------------------|
| (1) Check and High Pressure Relief Valve (Forward) | (4) Output Shaft            | (8) Charge Relief Valve                            | (11) Input Shaft             |
| (2) Pump Kidney Port A                             | (5) Neutral Valve (Forward) | (9) Check and High Pressure Relief Valve (Reverse) | (12) Case Relief Valve       |
| (3) Motor Kidney Port C                            | (6) P1 Port                 | (10) Pump Kidney Port B                            | (13) Motor Kidney Port D     |
|  | (7) P2 Port                 |  | (14) Neutral Valve (Reverse) |

**(2) Pump and Motor**

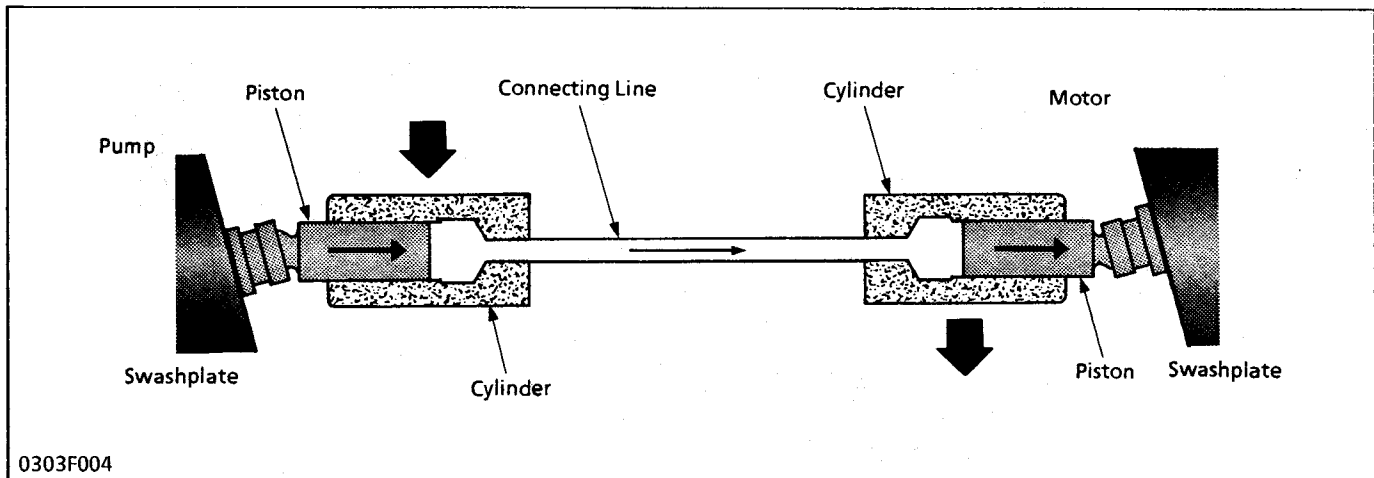

Pump and motor cylinder, each containing pistons, are connected by lines. Cylinders and lines are filled with oil. Pistons ride against swashplates located in pump and motor.

In the pump, as the cylinder rotates, pistons move across the sloping face of swashplate and slide in or out of their cylinder bores.

The oil, forced out by the pump pistons, causes the motor pistons to slide out of their cylinder bores. In the motor, sliding out of the cylinder and moving across the sloping face of swashplate, the pistons rotate the cylinder.

**(3) Variable Swashplate**

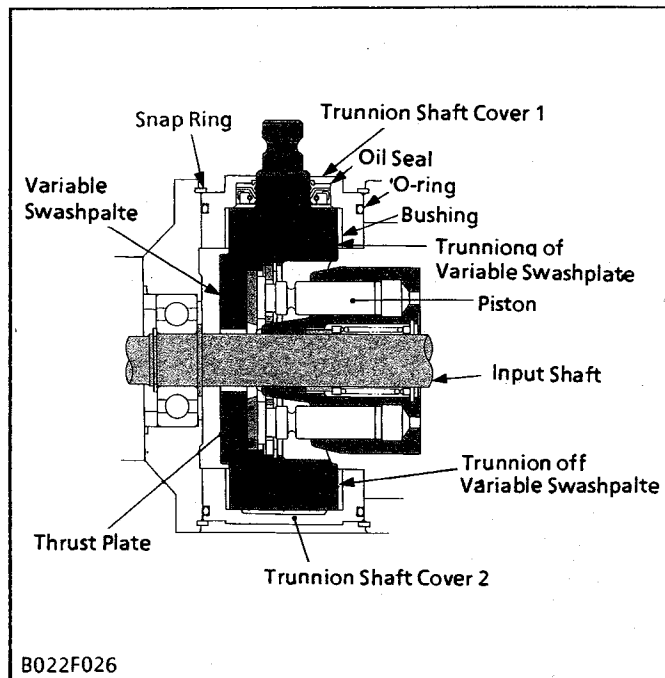

This pump is variable displacement one. The angle of its swashplate can be varied so that the volume and pressure of oil pumped by the pistons can be changed or the direction of oil flow can be reversed. The swashplate is moved around the trunnion shaft with the neutral holder, by stepping on the speed control pedal linked to the neutral holder.



(4) Oil Flow and Valves

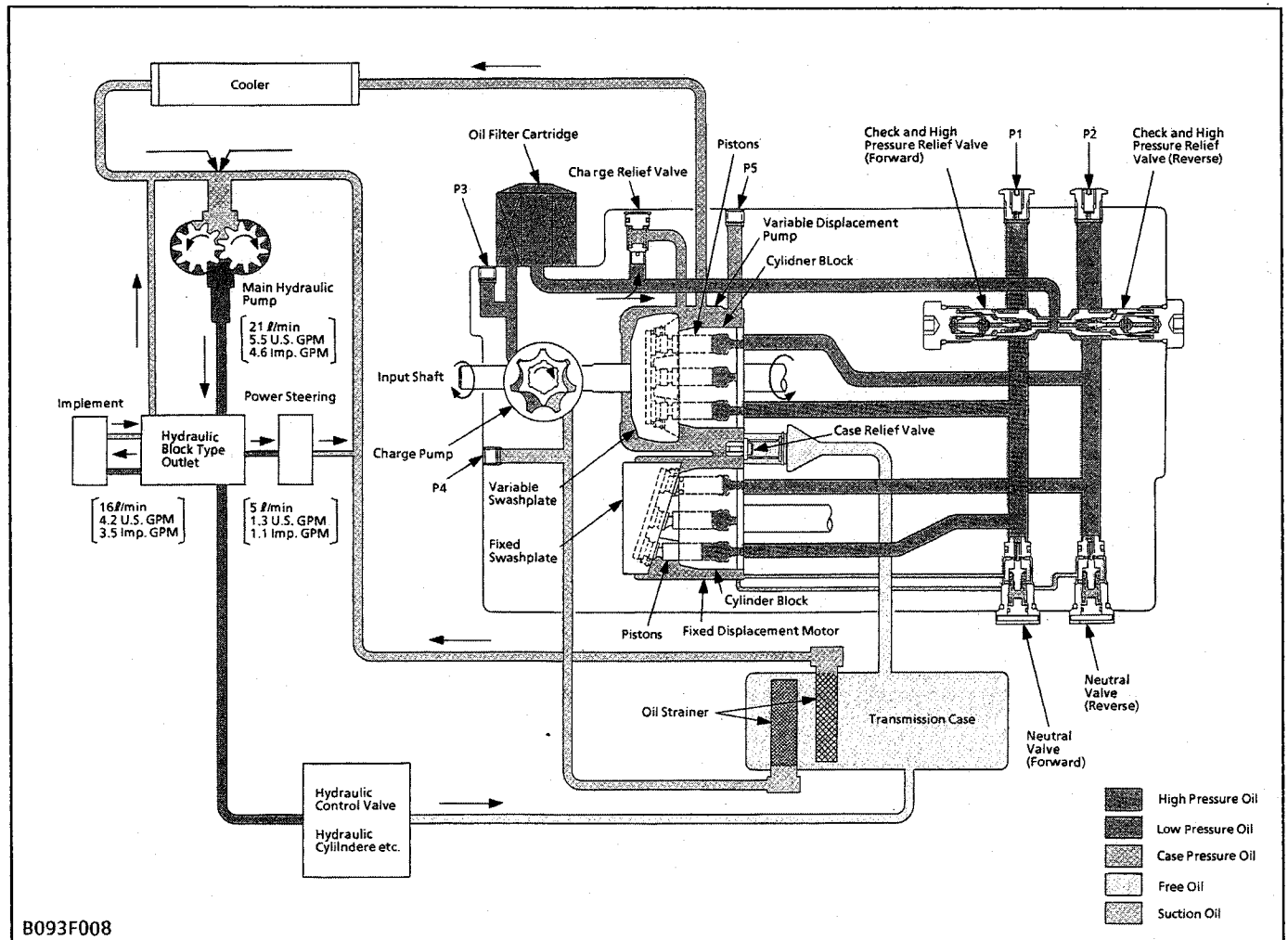

- P1: Port for checking high pressure (forward)
- P2: Port for checking high pressure (reverse)
- P3: Port for checking case pressure

- P4: Port for checking vacuum
- P5: Port for checking case pressure

The pump and motor are joined in a closed hydraulic loop and most of oil circulates within the main oil circuit. A little oil lubricates and oozes out from the clearance between the moving parts of the case. Then oil in the main oil circuit of the hydrostatic transmission needs to be supplied a want. So all of oil fed from the main hydraulic pump flows to the hydrostatic transmission for charging.

Only return oil from the hydraulic cylinder drops to the transmission case.

The charge oil aids smooth operation of piston pump and motor. The rest of the oil passes through the charge relief valve into the case. Then the oil passes to the main hydraulic pump through a cooler.

■ Charge Relief Valve

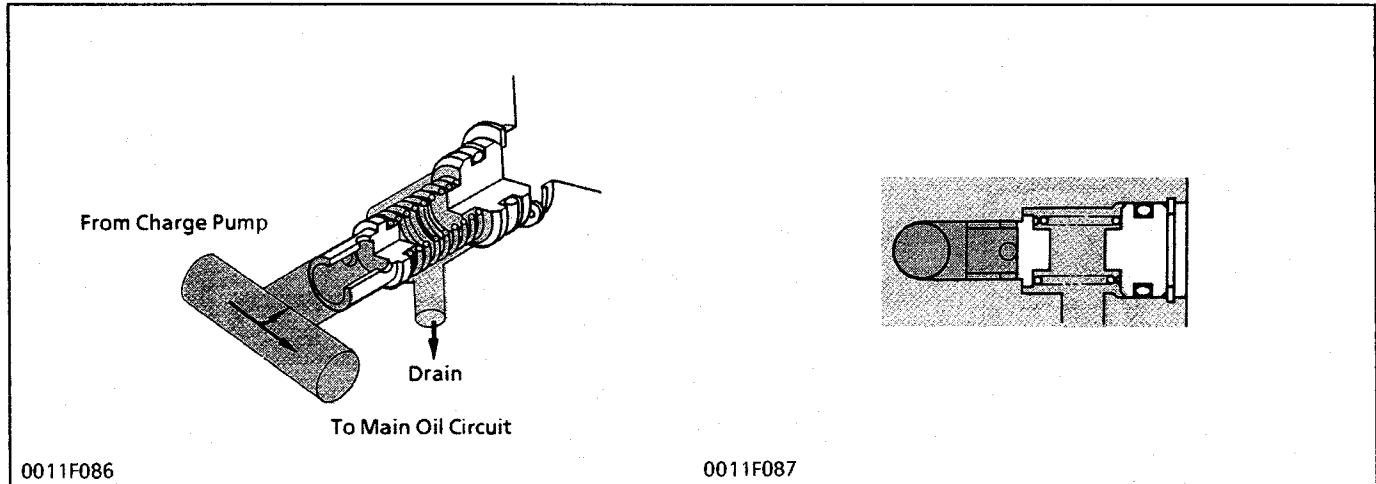

While pumped and filtered oil flows into the main oil circuit through the check valves, excessive oil passes to the case through the charge relief valve.

Oil temperature	Valve operating pressure
50 °C (122 °F)	392 to 588 kPa (4.0 to 6.0 kgf/cm <sup>2</sup> , 57 to 85 psi) more than case pressure

■ Neutral Valve

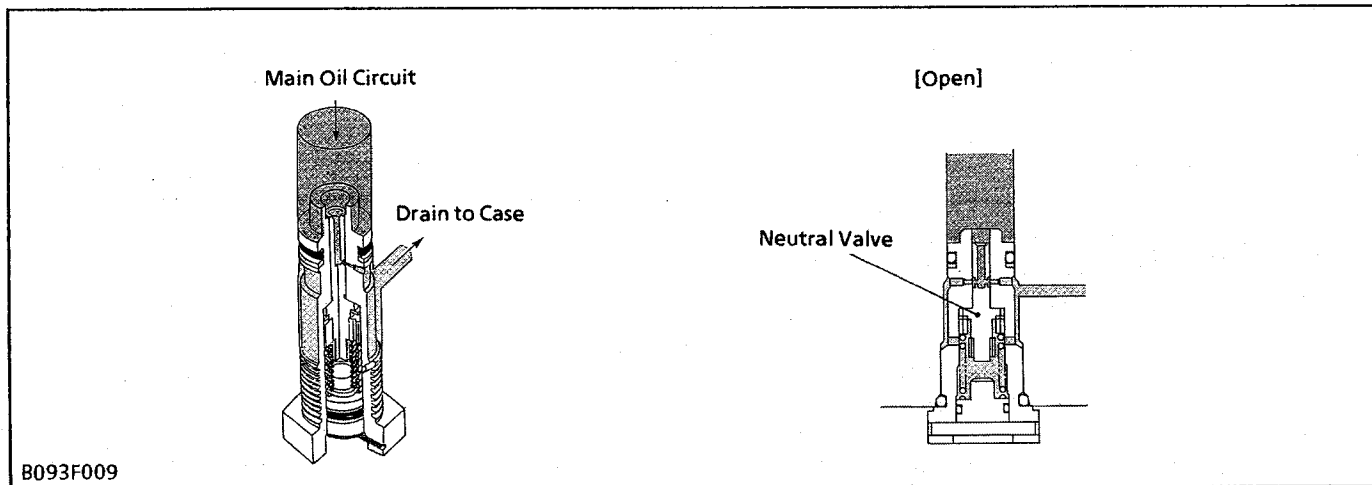

The neutral valves in the main oil circuit lines are open and pass the oil to the case when in neutral, and the oil pressure in their lines becomes low. And when the oil pressure in the high pressure line increases to a specified pressure, the neutral valve closes.

Oil temperature	Valve operating pressure	
50 °C (122 °F)	Close	2.45 to 3.73 MPa (25 to 38 kgf/cm <sup>2</sup> , 356 to 540 psi)
	Open	1.47 MPa (15 kgf/cm <sup>2</sup> , 213 psi)

■ Check and High Pressure Relief Valve

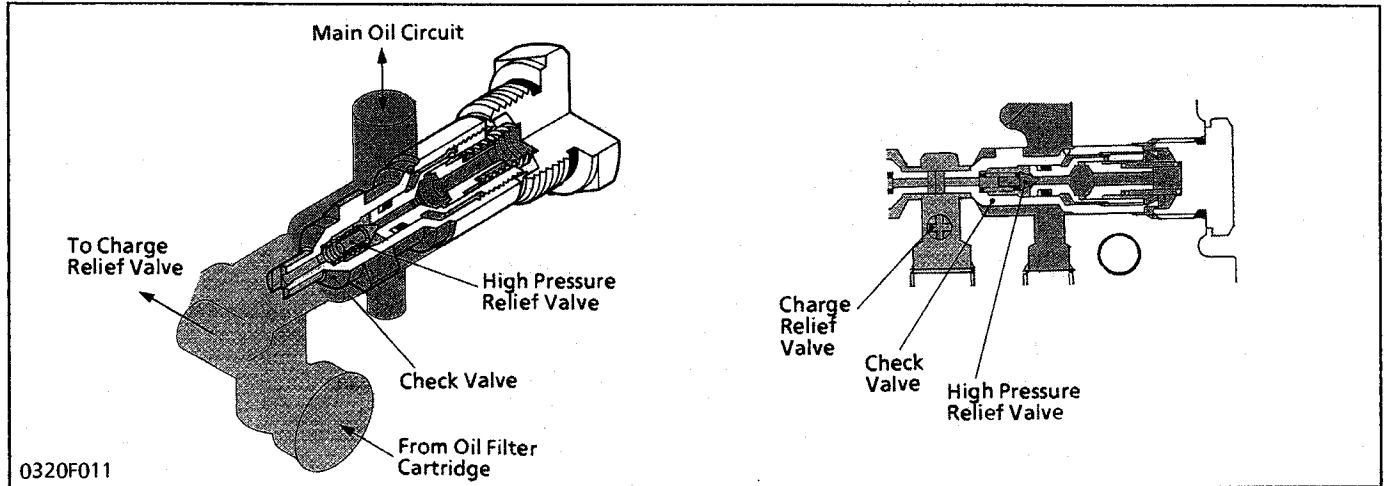

0320F011

The check and high pressure relief valves monitor the oil pressure in each line of the main oil circuit.

In neutral, both valves are open and charging oil enters into the main oil circuit through the valves.

At normal operation, the check valve in the high pressure side is closed and it pushes and opens the another one.

When excessively high pressure is built up in one line, the high pressure relief valve located in this line is open and the oil flows into another line.

Oil temperature	Relief valve operating pressure
50°C (122°F)	24.0 to 25.0 Mpa (245 to 255 kgf/cm <sup>2</sup> , 3485 to 3627 psi)

■ Case Relief Valve

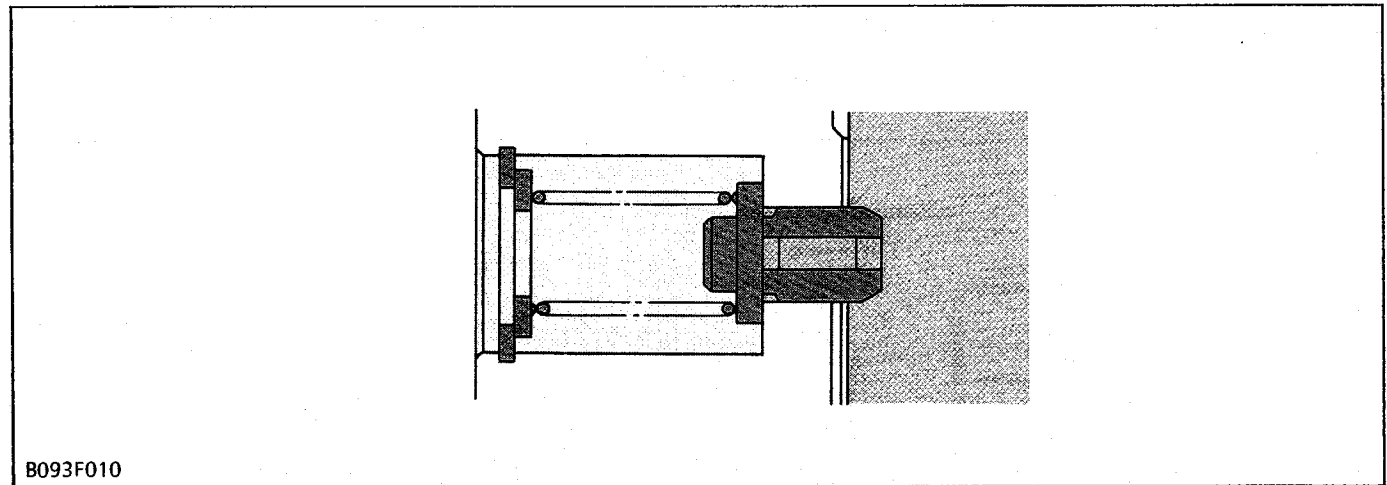

B093F010

The case relief valve monitors the oil pressure in the hydrostatic transmission case. When the oil pressure rises, it opens and flows the oil directly to the transmission case, so that the oil may not leak against the sealings.

Oil temperature	Valve operating pressure
50°C (122°F)	98 to 294 kpa (1 to 3 kgf/cm <sup>2</sup> , 14 to 43 psi)

(5) Operation

■ Neutral

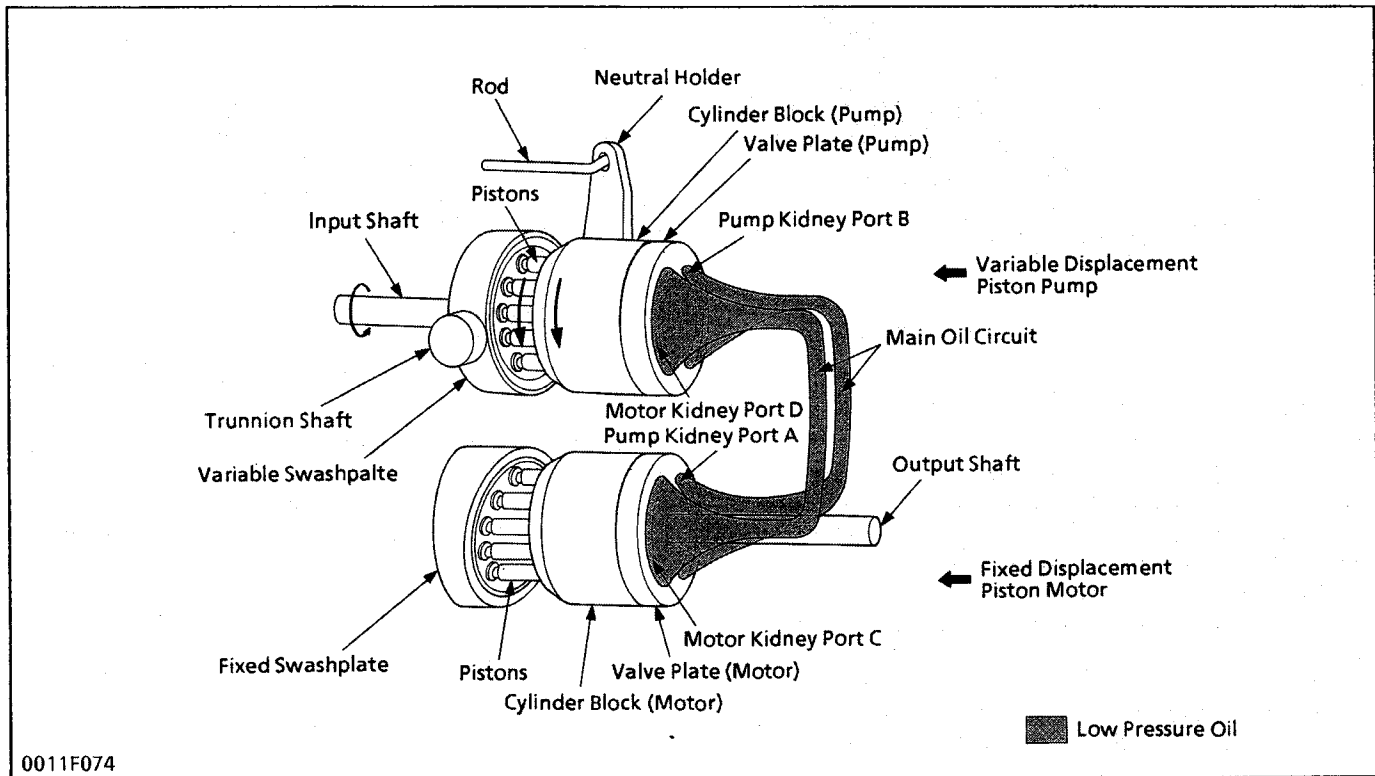

0011F074

When the speed control pedal is in neutral, the variable swashplate is at right angles to the pump pistons and they only rotate with cylinder block without reciprocating. Since the oil is not being

pumped to the motor, the cylinder block in the motor is stationary and the output shaft does not move.

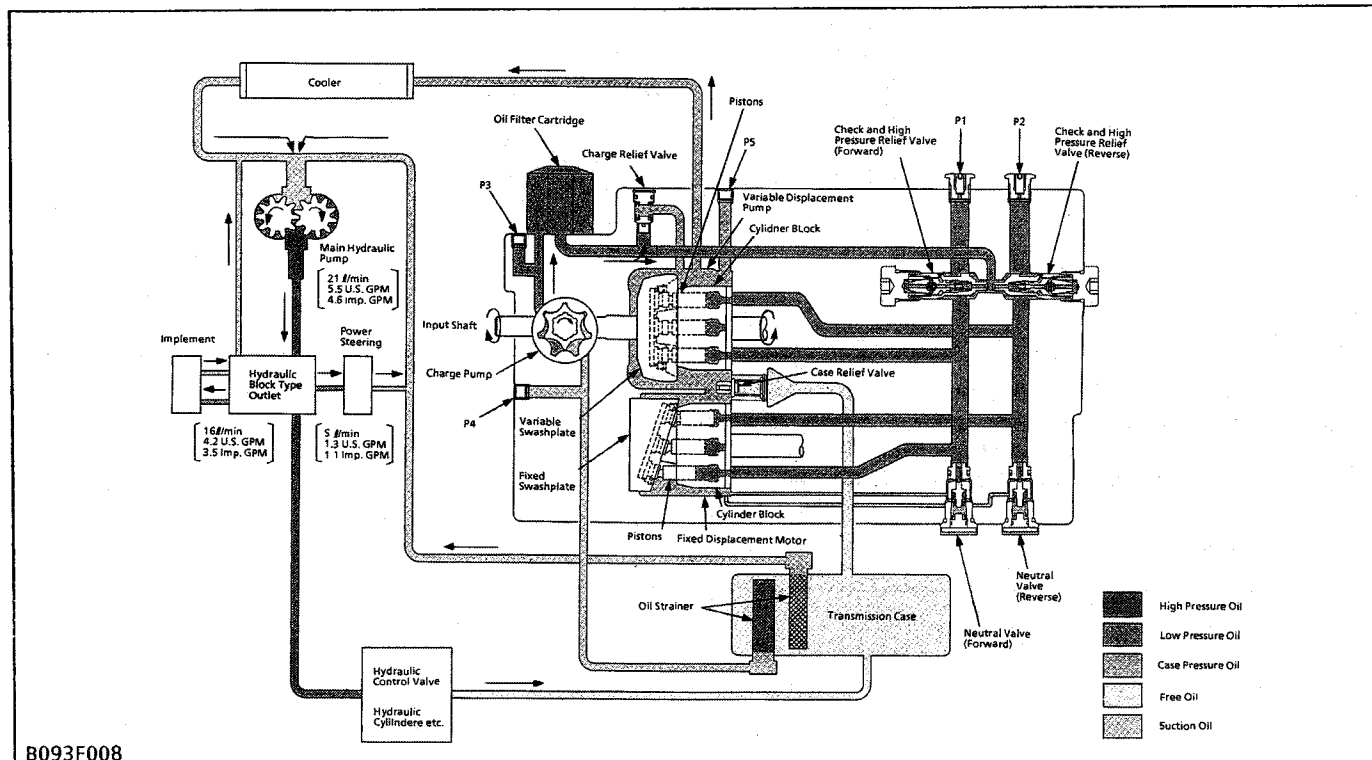

B093F008

■ Forward

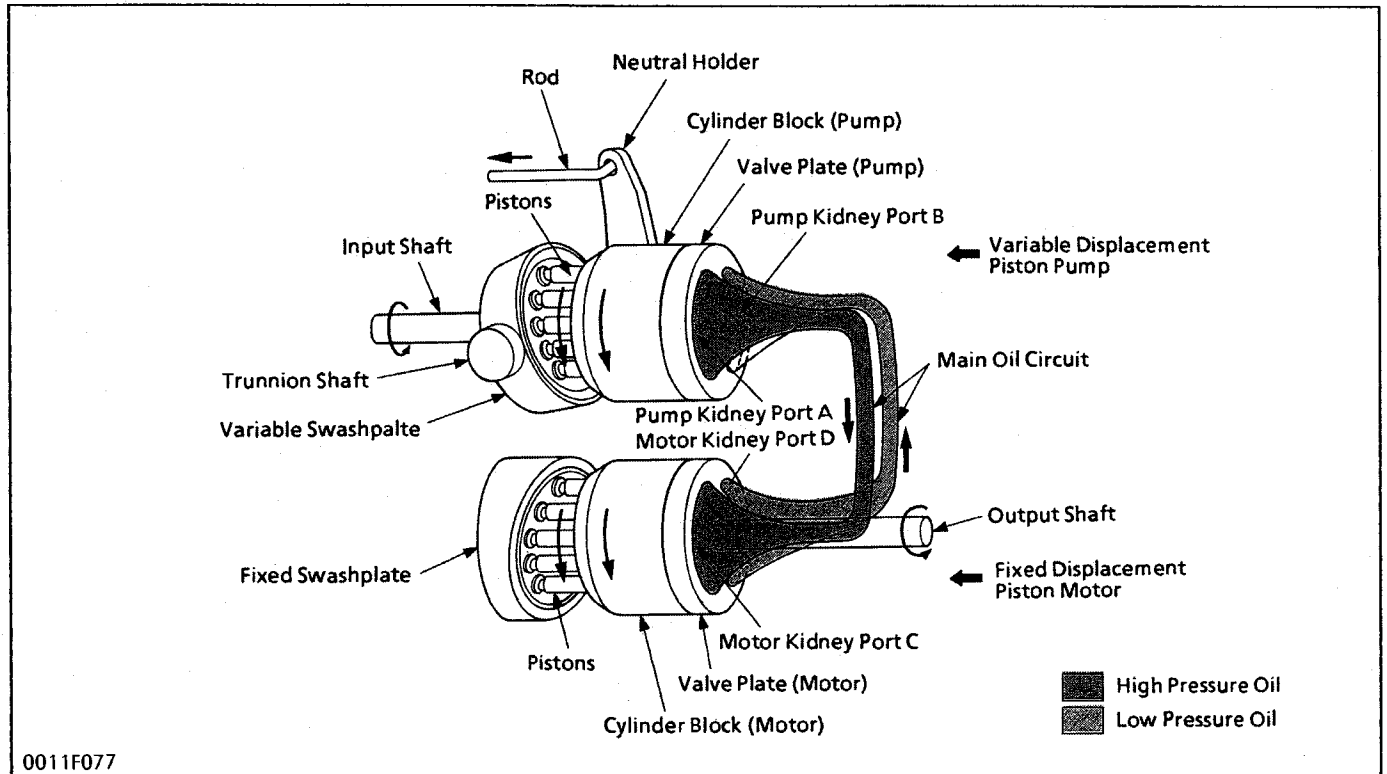

0011F077

When the speed control pedal is stepped on and in forward, the variable swashplate is tilted as shown in figure above.

As the pump cylinder block rotates with the input shaft, oil is forced out of pump kidney port A at high pressure. As pressure oil enters motor kidney port C, the pistons, which align with port C, are pushed against the swashplate and slide down the inclined surface.

Then the output shaft rotates with the motor cylinder block. This drives the machine forward and the angle of pump swashplate determines the output shaft speed.

As the motor cylinder block continues to rotate, oil is forced out of motor kidney port D at low pressure and returns to the pump.

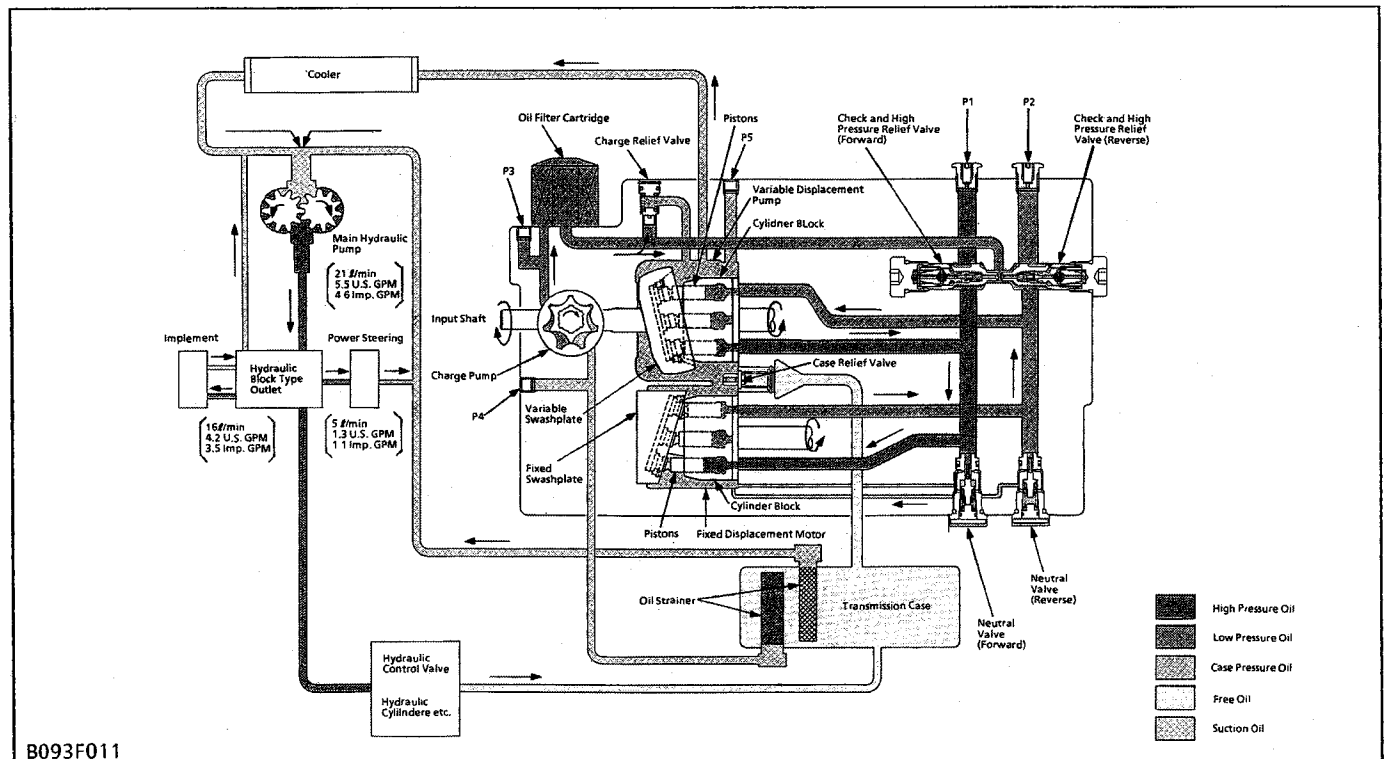

B093F011

■ Reverse

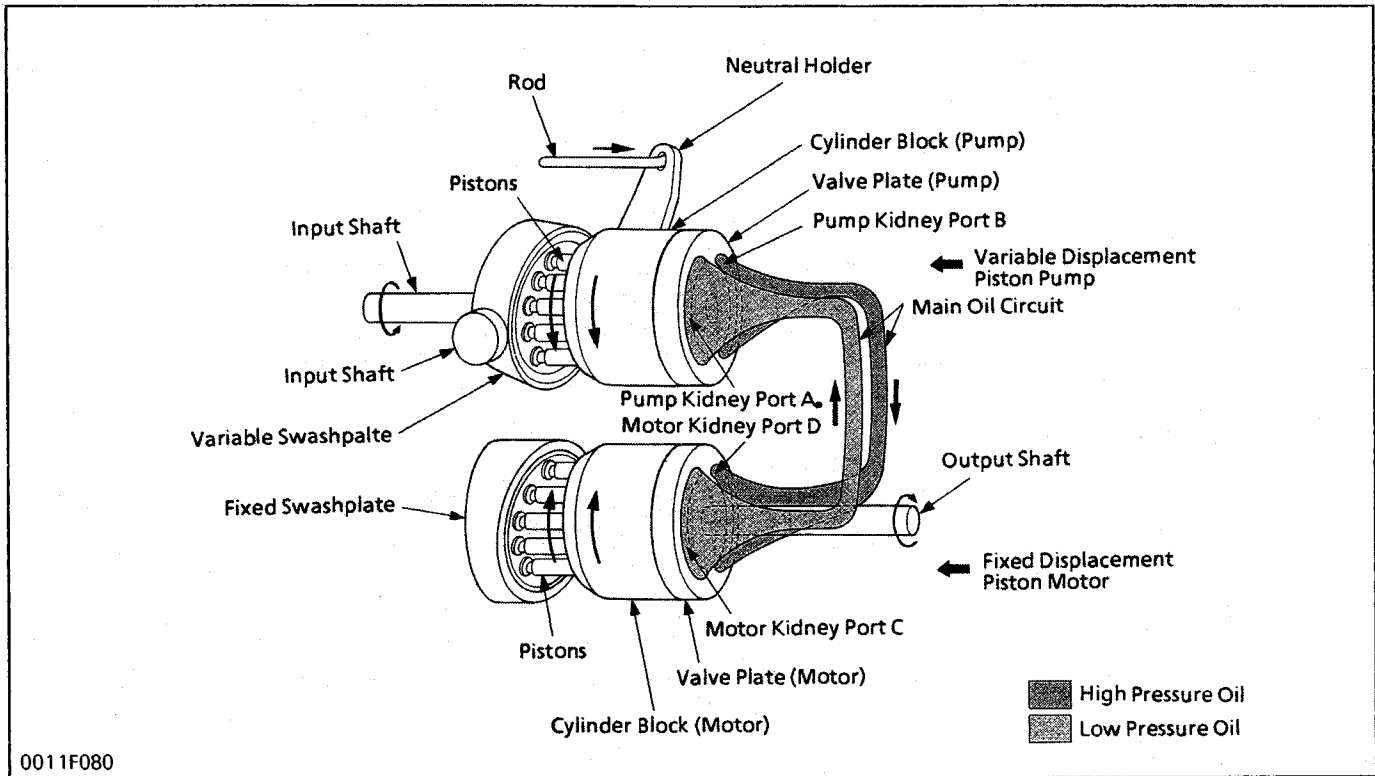

0011F080

When the speed control pedal is stepped on and in reverse, the variable swashplate is tilted as shown in figure above.

As the pump cylinder block rotates with the input shaft, oil is forced out of pump kidney port B at high pressure. As pressure oil enters motor kidney port D, the pistons, which align with port D, are pushed against the swashplate and slide down the inclined surface.

Then the output shaft rotates with the motor cylinder block. This drives the machine rearward and the angle of pump swashplate determines the output shaft speed.

As the motor cylinder block continues to rotate, oil is forced out of motor kidney port C at low pressure and returns to the pump.

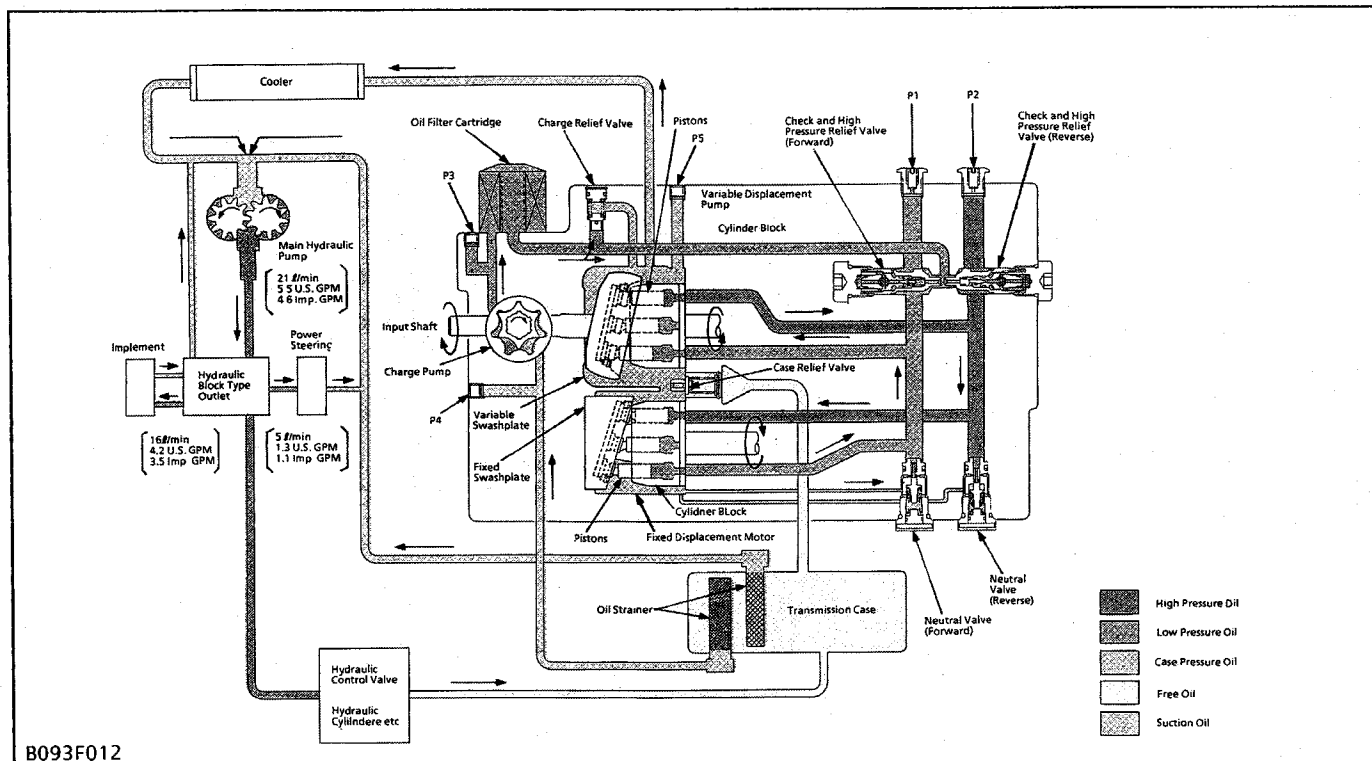

B093F012

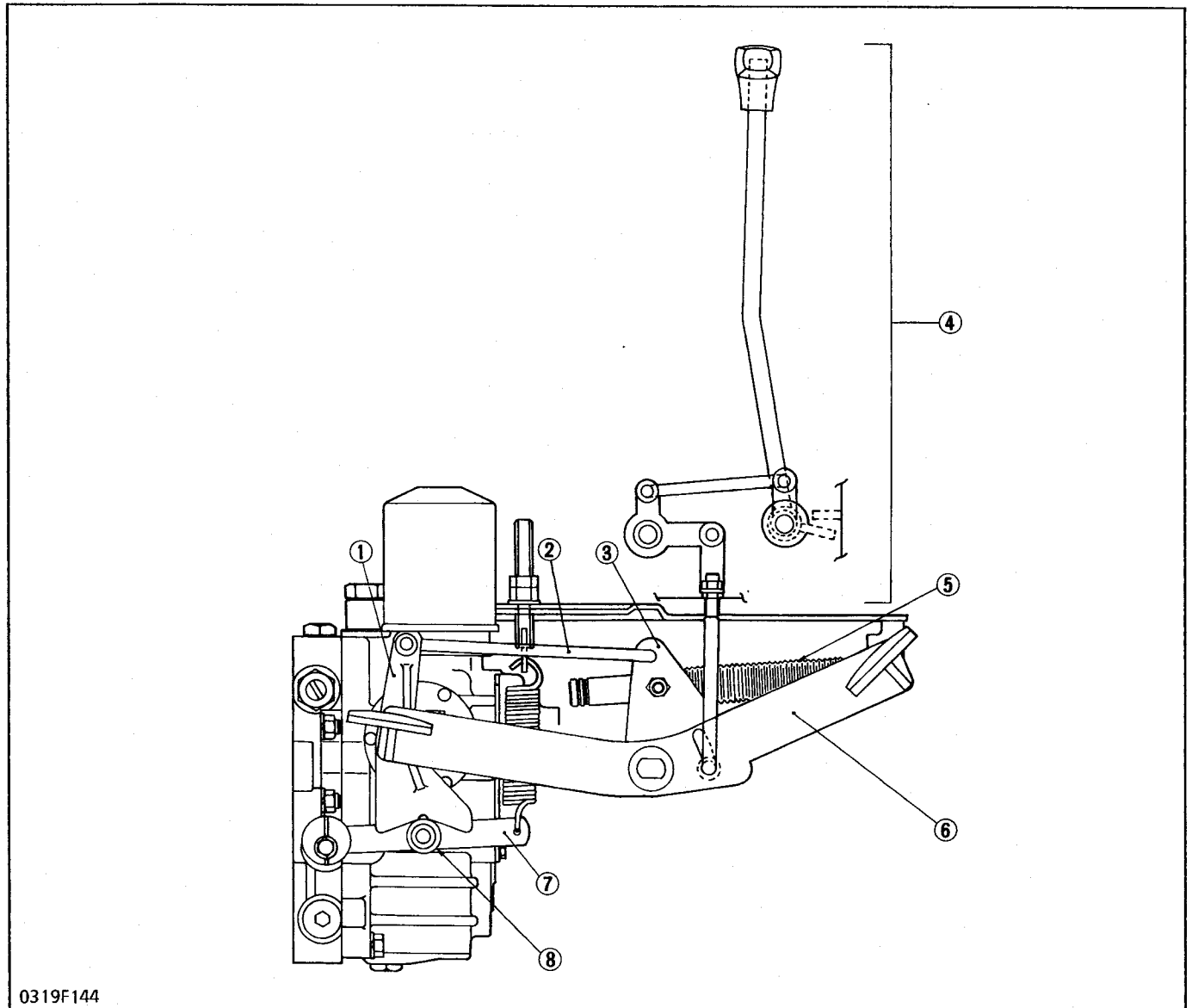
**(6) Control Linkage**

0319F144

- |                       |                      |                               |                        |
|-----------------------|----------------------|-------------------------------|------------------------|
| (1) Neutral Holder    | (3) Rod Guide        | (5) Damper                    | (7) Neutral Holder Arm |
| (2) Speed Control Rod | (4) Speed Set Device | (6) Speed Control Pedal Shaft | (8) Roller             |

The speed control pedal (6) and the trunnion shaft of variable swashplate are linked with the rod guide (3), the speed control rod (2) and the neutral holder (1). As the front footrest of the pedal is depressed, the swashplate rotates and forward traveling speed increases. Depressing the rear footrest increases reverse speed.

The roller (8) on the neutral holder arm (7) hinged with spring seats the detent of the neutral holder (1) so that the neutral holder returns to neutral.

Then, the swashplate is returned to neutral with the neutral holder, when the pedal is released. The damper (5) connected to the rod guide (3) restricts the movement of the linkage to prevent abrupt operation or reversing.

The speed set device (4) linked to the rod guide (3) enables the linkage not to return to neutral and to keep a certain forward speed while the speed control pedal (6) is released.

On B6200HST, this device is installed as optional.

# TRANSMISSION

## NOTE

- Tractor serial number B6200HST 2WD above 20001  
B6200HST 4WD above 60001  
B7200HST 2WD above 20001  
B7200HST 4WD above 60001

## SERVICING SPECIFICATIONS

Item		Factory Specification		Allowable Limit
Speed Set Lever	Force (See page BS.2-3)	29.4 to 34.3 N 3.0 to 3.5 kgf 6.6 to 7.7 lbs		-
Check and High Pressure Relief Valve	Setting Pressure [Relief Valve]	24.0 to 25.0 MPa 245 to 255 kgf/cm <sup>2</sup> 3485 to 3627 psi (Oil temperature at 50 °C, 122 °F)		-
	Spring Length (short) [Relief Valve]	(free)	12.4 mm 0.488 in.	-
	Spring Length (long) [Check Valve]	load 41.84 N, 4.27 kgf, 9.41 lbs	10.5 mm 0.413 in.	-
Case Relief Valve	Setting Pressure	98 to 294 kPa 1 to 3 kgf/cm <sup>2</sup> 14 to 43 psi (Oil temperature at 50 °C, 122 °F)		-
Case Relief Valve Spring	Spring Length	(free)	23.0 mm 0.906 in.	-
		load 29.4 N, 3.0 kgf, 6.6 lbs	15.0 mm 0.591 in.	-
Charge Relief Valve	Setting Pressure	392 to 558 kPa 4.0 to 6.0 kgf/cm <sup>2</sup> 57 to 85 psi more than case pressure (Oil temperature at 50 °C, 122 °F)		-
Piston to Bore	Clearance	0.02 mm 0.0008 in.		0.04 mm 0.0016 in.
Slipper	Thickness	3.00 mm 0.118 in.		2.90 mm 0.114 in.



## SERVICING SPECIFICATIONS (Continued)

Item		Factory Specification	Allowable Limit
Vacuum	Setting Pressure	120 mmHg (Oil temperature at 25 °C, 77 °F)	—
		60 mmHg (Oil temperature at 50 °C, 122 °F)	—
		35 mmHg (Oil temperature at 80 °C, 176 °F)	220 mmHg (Oil temperature at 80 °C, 176 °F)
Neutral Valve	Setting Pressure	Close 2.45 to 3.73 MPa [25 to 38 kgf/cm <sup>2</sup> , 356 to 540 psi] Open 1.47 MPa [15 kgf/cm <sup>2</sup> , 213 psi] (Oil temperature at 50 °C, 122 °F)	—
	Spring Length	(free) 18.4 mm 0.7244 in. load 43.2 N, 4.4 kgf, 9.7 lbs 13.9 mm 0.5472 in.	— —

## TIGHTENING TORQUES

Item	N·m	kgf·m	ft-lbs
Neutral Adjuster	18.6 to 32.3	1.9 to 3.3	13.7 to 23.9
Charge Pump	23.5 to 27.5	2.4 to 2.8	17.4 to 20.3
Motor Swashplate	15.7 to 20.6	1.6 to 2.1	12 to 15
Port-block	48.1 to 55.9	4.9 to 5.7	35.4 to 41.2
High Relief Valve Seat	23.5 to 29.4	2.4 to 3.0	17.4 to 21.7
High Relief Valve Cap Nut	58.8 to 68.6	6.0 to 7.0	43.4 to 50.6
Neutral Valve	53.9 to 63.7	5.5 to 6.5	39.8 to 47.0
Plug (Drain)	49.0 to 58.8	5.0 to 6.0	36.2 to 43.4
Plug (P1, P2)	19.6 to 24.5	2.0 to 2.5	14.5 to 18.1
Plug (P1, P2) PT 3/8	29.4 to 39.2	3.0 to 4.0	21.7 to 28.9
Plug Seat (P1, P2)	49.0 to 58.8	5.0 to 6.0	36.2 to 43.4
Plug (P3, P4, P5)	8.8 to 10.8	0.9 to 1.1	6.5 to 8.0
HST Case to Transmission Case	48.1 to 55.9	4.9 to 5.7	35.4 to 41.2
Mid PTO Case Bearing Holder	13.7 to 19.6	1.4 to 2.0	10.1 to 14.5
Case Cover to Case			
Mid PTO Case to Transmission Case	48.1 to 55.9	4.9 to 5.7	35.4 to 41.2
Rear Cover Mounting Screw	39.2 to 64.7	4.0 to 6.6	28.9 to 47.7
PTO Shaft Screw	18.6 to 32.4	1.9 to 3.3	13.7 to 23.9

■ NOTE

- Tractor serial number **B6200HST 2WD** above 20001
- B6200HST 4WD** above 60001
- B7200HST 2WD** above 20001
- B7200HST 4WD** above 60001

# CHECKING, DISASSEMBLING AND SERVICING

## [1] SPEED SET DEVICE

### DISASSEMBLING AND ASSEMBLING

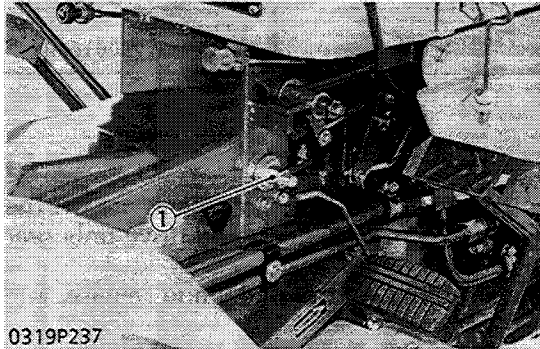

#### Speed Set Lever

1. Measure the force to move the speed set lever A forward at its top (grip).
2. If the force is not within the factory specification, turn the nut (1) to adjust.

Force to move the lever	Factory spec.	29.4 to 34.3 N 3.0 to 3.5 kgf 6.6 to 7.7 lbs
-------------------------	---------------	--

#### (When reassembling)

- After installing the spring (3), align the head of nut (2) with the punched mark (4).

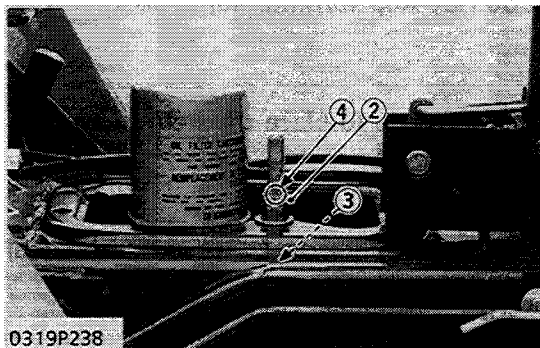

- (1) Nut
- (2) Nut

- (3) Spring
- (4) Punched Mark

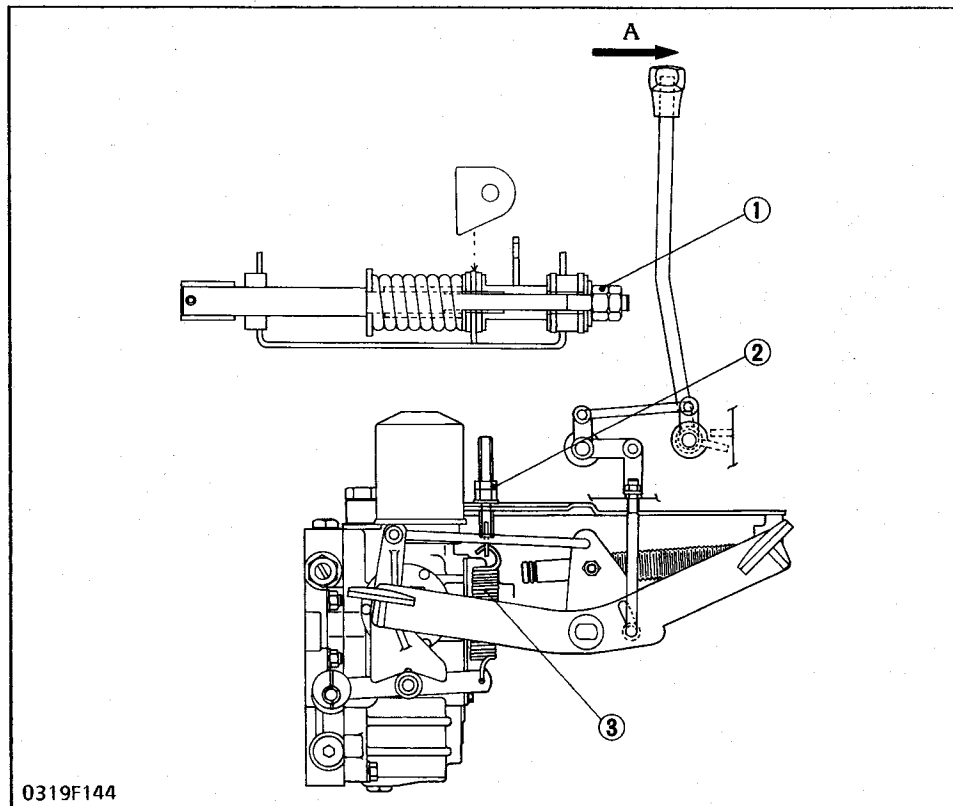

## [2] HYDROSTATIC TRANSMISSION

### CHECKING AND ADJUSTING

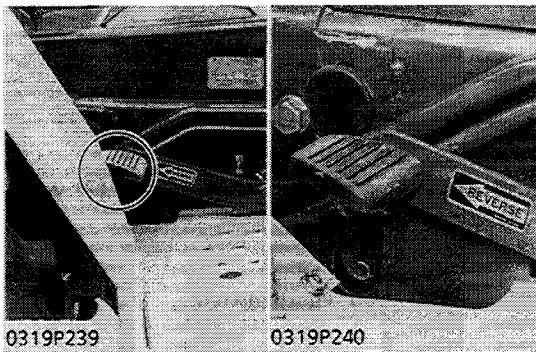
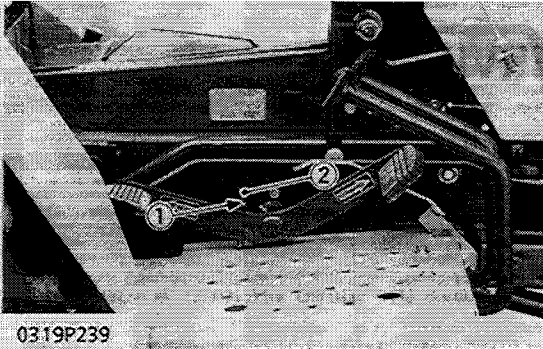

#### Reverse Speed

1. Lift the rear of the tractor so that the rear wheels are off the ground.
2. Set the engine speed at 2500 rpm and depress the differential lock pedal.
3. If the rear wheels do not turn within the factory specifications, loosen the lock nut (1) and adjust the bolt (2).

Rear wheel rpm	Factory spec.	64 to 68 rpm (Engine at 2500 rpm)
----------------	---------------	--------------------------------------

(1) Lock Nut

(2) Bolt

#### Neutral

1. Lift the rear of the tractor so that the rear wheels are off the ground and run the engine at low idling and drive only rear wheels.
2. Depress the one end of speed control pedal and release, and do the same at the other end.
3. If the rear wheels do not stop turning, adjust as following procedure.

#### NOTE

- Loosen the screw and be sure to place the neutral adjuster with its longer groove upward.

#### Adjusting Neutral

1. Rotate the neutral adjuster counterclockwise so that the rear wheels turn forward.
2. Then rotate it clockwise until wheels stop completely.
3. Put a mark on the clutch housing aligning the groove on neutral adjuster.
4. Rotate the neutral adjuster clockwise so that the rear wheels turn reverse.
5. Then rotate it counterclockwise until wheels stop completely.
6. Put a mark on the clutch housing aligning the groove on neutral adjuster.
7. Hold the neutral adjuster so that its groove is at the middle of the marks and tighten the screw.

#### NOTE

- When the wheels tend to turn forward, rotate the neutral adjuster clockwise.
- When the wheels tend to turn reverse, rotate the neutral adjuster counterclockwise.

Tightening torque	Neutral adjuster to case	19 to 32 N·m 1.9 to 3.3 kgf·m 13 to 24 ft·lbs
-------------------	--------------------------	---

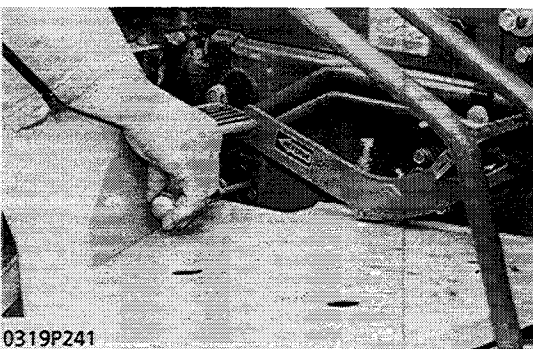
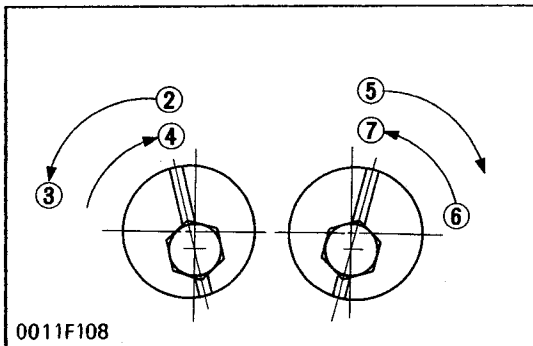

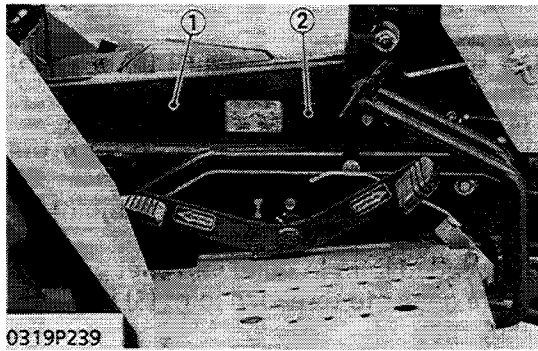

0319P239

### Oil Pressure in Hydrostatic Transmission

1. Clean and clear the work area, and fully engage the parking brake.
2. Remove the knob screws (2) and sub cover (1).
3. Measure the following oil pressures using Hydrostatic Transmission Testing Kit (Code No. 07916-52040) as instructed.

(1) Sub Cover

(2) Knob Screw

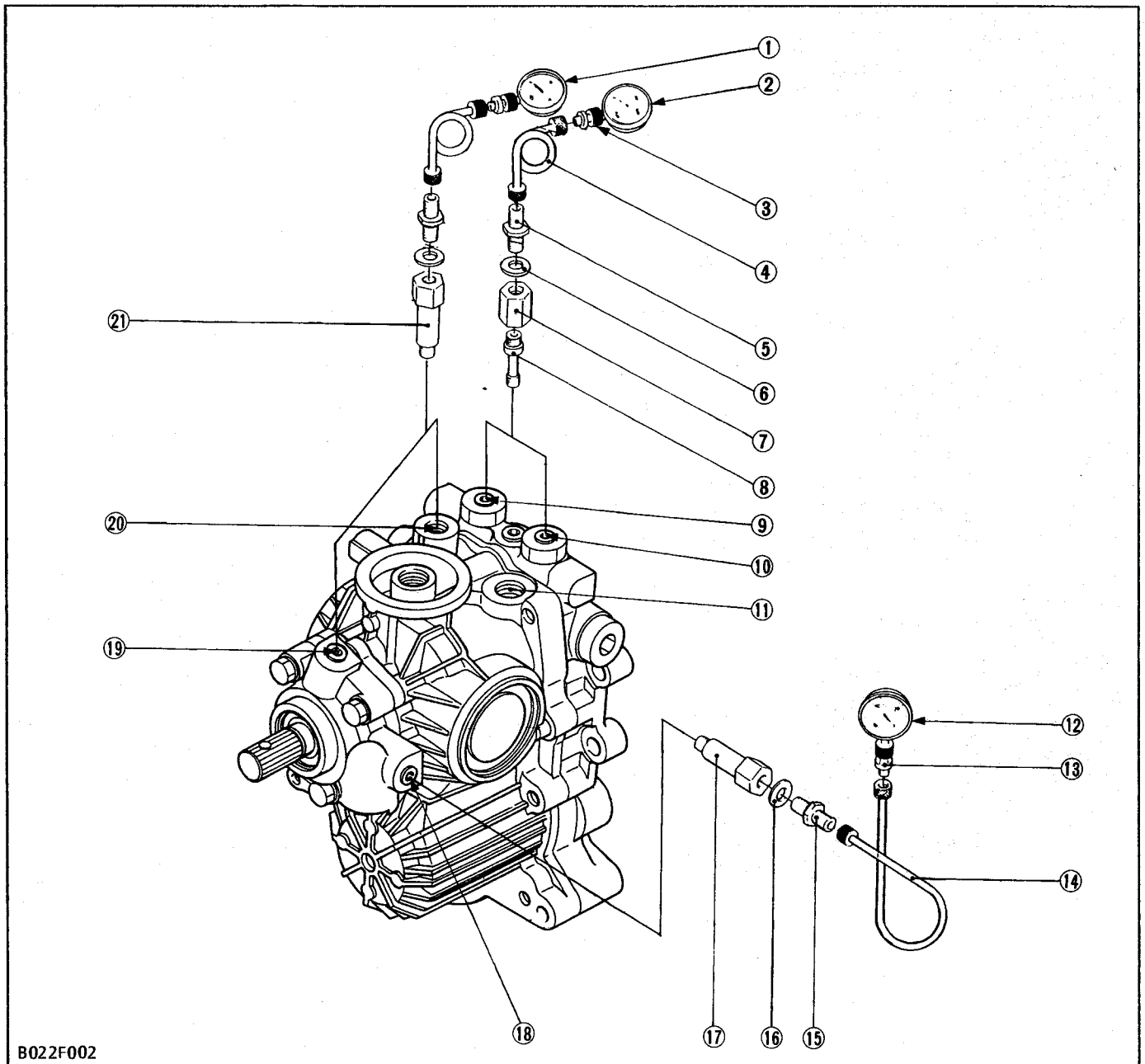

B022F002

- |  |                                       |                                   |
|--|---------------------------------------|-----------------------------------|
| (1) Pressure Gauge (07916-51301)                                 | (7) Connector 1 (07916-60811)         | (15) Thread Joint (07916-50341)   |
| (2) Pressure Gauge (High Pressure)(07916-50322)                  | (8) Connector 2 (07916-60821)         | (16) Gasket (04714-00200)         |
| (3) Threaded Joint in Relief Valve Pressure Tester (07916-50401) | (9) High Pressure (Reverse), P2 port  | (17) Long Connector (07916-60831) |
| (4) Cable (07916-51331)  | (10) High Pressure (Forward), P1 port | (18) Vacuum, P4 port              |
| (5) Thread Joint (07916-50341)                                   | (11) T1 port                          | (19) Charge Pressure, P3 port     |
| (6) Gasket (04714-00200)   | (12) Vacuum Gauge (07916-51331)       | (20) Case Pressure, P5 port       |
|  | (13) Pressure Tester (07916-50401)    | (21) Long Connector (07916-60831) |
|  | (14) Cable (07916-50331)              |                                   |

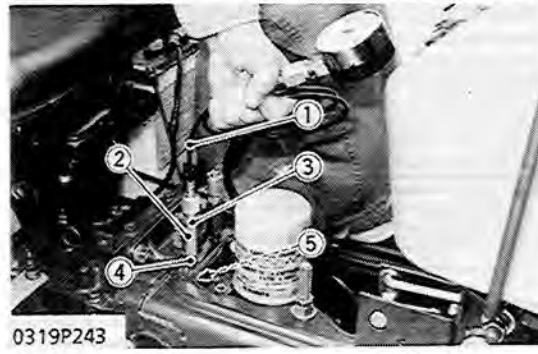
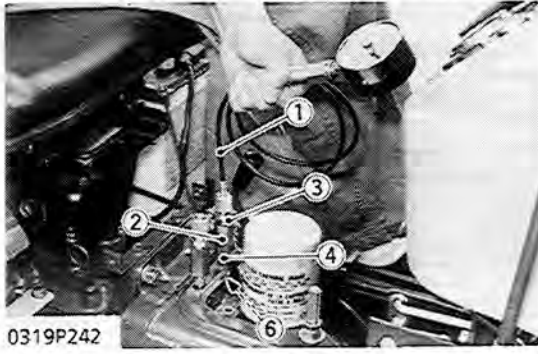

**High Relief Pressure**

1. Remove the M10 hex socket head plug from P1 (6) or P2 (5) port (P1 is for forward and P2 is for reverse).
2. Install connector 2 (4) to P1 (forward) or P2 (reverse) port.
3. Assemble connector 1 (2) and threaded joint (3) with the gasket between them.
4. Install the assembled connector 1 (2) and threaded joint (3) to connector 2 (4).
5. Install the cable (1), threaded joint in relief valve set pressure tester and high pressure gauge to threaded joint (3) in order.
6. Run the engine at 2600 rpm.
7. Place the high-low shift lever in high.
8. Depress the speed control pedal approx. 10 mm (0.39 in.) which rotates the trunnion shaft 0.087 rad (5.0°).

High relief pressure (Oil temperature at 50 °C, 122 °F)	Factory spec.	24.0 to 25.0 MPa 245 to 255 kgf/cm <sup>2</sup> 3485 to 3627 psi
---	---------------	--

**IMPORTANT**

- Measure quickly so that the relief valve may not be in operation more than 10 seconds.

**NOTE**

- High pressure gauge is 30 MPa (300 kgf/cm<sup>2</sup>, 4260 psi) full scale.

**(When reassembling)**

- Install the M10 plug to the port with the gasket laying on its seat.

Tightening torque	Plug (P1, P2 port)	19.6 to 24.5 N·m 2.0 to 2.5 kgf·m 14 to 18 ft-lbs
	Plug seat (P1, P2 port)	49.0 to 58.8 N·m 5.0 to 6.0 kgf·m 36.2 to 43.4 ft-lbs

- |                    |                 |
|--------------------|-----------------|
| (1) Cable          | (4) Connector 2 |
| (2) Connector 1    | (5) P2 Port     |
| (3) Threaded Joint | (6) P1 Port     |

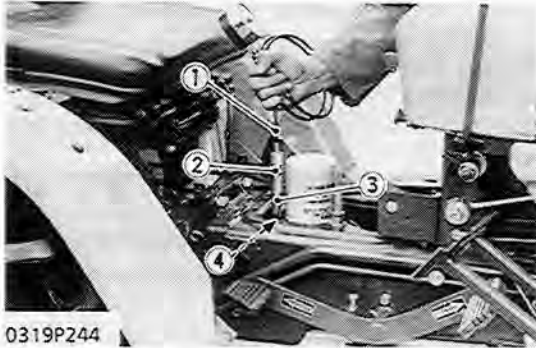

0319P244

- (1) Cable
- (2) Threaded Joint
- (3) Long Connector
- (4) P5 Port

**Case Relief Pressure**

1. Remove the PT 1/4 plug from P5 port (4), with care not to allow any particle of sealing tape enter into the port.
2. Install the long connector (3) to P5 port with sealing tape on its thread.
3. Install the threaded joint (2) to long connector with the gasket between them.
4. Install the cable (1), threaded joint in relief valve set pressure tester and low pressure gauge to threaded joint in order.
5. Run the engine at 2600 rpm.
6. Place the high-low shift lever in neutral.
7. Release the speed control pedal to set in neutral.
8. After measuring the case pressure, remove the eye joint from T1 port and plug the port with PF 3/8 screw to measure the case relief pressure.

Case relief pressure (Oil temperature at 50 °C, 122 °F)	Factory spec.	98 to 294 kPa 1 to 3 kgf/cm <sup>2</sup> 14 to 43 psi
---	---------------	---

**NOTE**

- Low pressure gauge is 2 MPa (20 kgf/cm<sup>2</sup>, 284 psi) full scale.

**(When reassembling)**

- Install the PT 1/4 plug to the P3 port with the sealing tape on its thread.

Tightening torque	Plug (P5 port)	8.8 to 10.8 N·m 0.9 to 1.1 kgf·m 6.5 to 7.9 ft-lbs
-------------------	----------------	--

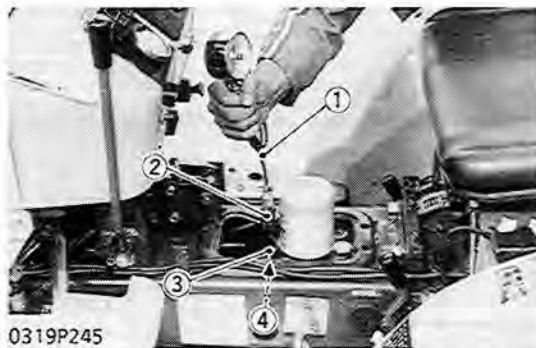

0319P245

- (1) Cable
- (2) Threaded Joint
- (3) Long Connector
- (4) P3 Port

**Charge Pressure**

1. Remove the PT 1/4 plug from P3 port (4), with care not to allow any particle of sealing tape enter into the port.
2. Install the long connector (3) to P3 port with sealing tape on its thread.
3. Install the threaded joint (2) to long connector with the gasket between them.
4. Install the cable (1), and threaded joint in order.
5. Run the engine at 2600 rpm.
6. Place the high-low shift lever in neutral.
7. Release the speed control pedal to set in neutral.

Charge pressure (Oil temperature at 50 °C, 122 °F)	Factory spec.	392 to 558 kPa 4.0 to 6.0 kgf/cm <sup>2</sup> 57 to 85 psi
--	---------------	--

**NOTE**

- Low pressure gauge is 2 MPa (20 kgf/cm<sup>2</sup>, 284 psi) full scale.

**(When reassembling)**

- Install the PT 1/4 plug to the P3 port with the sealing tape on its thread.

Tightening torque	Plug (P3 port)	8.8 to 10.8 N·m 0.9 to 1.1 kgf·m 6.5 to 7.9 ft-lbs
-------------------	----------------	--



0319P246

- (1) P4 Port
- (2) Long Connector
- (3) Threaded Joint
- (4) Cable

**Vacuum**

1. Remove the PT 1/4 plug from P4 port (1), with care not to allow any particle of sealing tape enter into the port.
2. Install the long connector (2) to P4 port with sealing tape on its thread.
3. Install the threaded joint (3) to long connector with the gasket between them.
4. Install the cable (4), threaded joint in relief valve set pressure tester and vacuum gauge to threaded joint (3) in order.
5. Run the engine at 2600 rpm.
6. Place the high-low shift lever in neutral.
7. Release the speed control pedal to set in neutral.

Vacuum (Oil temperature)	Factory spec.	120 mm Hg (at 25 °C, 77 °F) 60 mm Hg (at 50 °C, 122 °F) 35 mm Hg (at 80 °C, 176 °F)
	Allowable limit	220 mm Hg (at 80 °C, 176 °F)

**NOTE**

- Vacuum gauge is 760 mm Hg (30 in. Hg) full scale.

**(When reassembling)**

- Install the PT 1/4 plug to the P4 port with the sealing tape on its thread.

Tightening torque	Plug (P3 port)	8.8 to 10.8 N·m 0.9 to 1.1 kgf·m 6.5 to 7.9 ft·lbs
-------------------	----------------	--

**DISASSEMBLING AND ASSEMBLING**

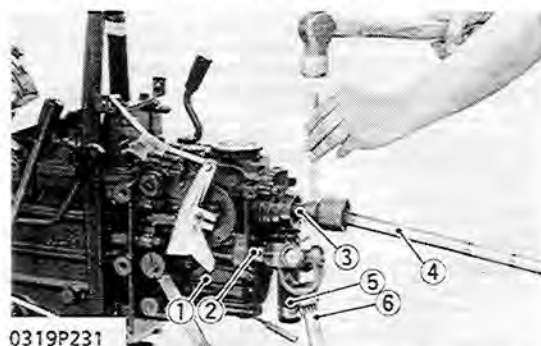

0319P231

- (1) HST
- (2) Front Wheel Drive Shaft
- (3) 1st Shaft
- (4) Propeller Shaft
- (5) Hose
- (6) Drive Shaft

**Hydrostatic Transmission**

1. Remove the propeller shaft (4) from the 1st shaft (3).
2. Remove the drive shaft (6) from the front wheel drive shaft (2). (4WD type only)
3. Loosen the hole clamp and remove the hose (5).
4. Remove the HST mounting screws, and remove the HST (1).

**(When reassembling)**

- After inserting the spring pin into the 1st shaft and drive shaft, lock the spring pin with a wire.
- Be sure to replace the gasket with a new one.

Tightening torque	HST mounting screw	48.1 to 55.9 N·m 4.9 to 5.7 kgf·m 35.4 to 41.2 ft·lbs
-------------------	--------------------	---

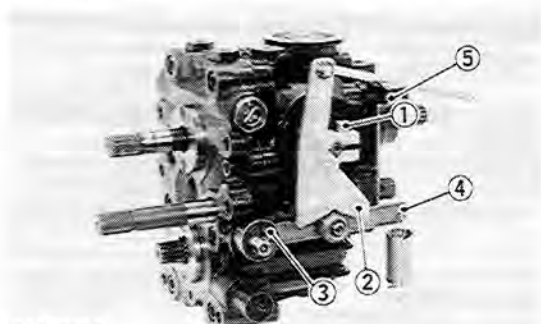

0319P256

- (1) Screw
- (2) Neutral Holder
- (3) Neutral Adjuster
- (4) Neutral Holder Arm
- (5) Spring Holder

**Neutral Holder**

1. Place parting marks on the neutral adjuster (3) and the neutral holder arm (4).
2. Remove the screws and spring holder (5).
3. Remove the screw and the neutral holder arm (4).
4. Remove the screw (1) and pull out the neutral holder (2).

**(When reassembling)**

- Aligning the parting marks, install the neutral adjuster and the neutral holder arm.

Tightening torque	Neutral holder arm mounting screw	18.6 to 32.4 N·m 1.9 to 3.3 kgf·m 14 to 24 ft·lbs
-------------------	-----------------------------------	---

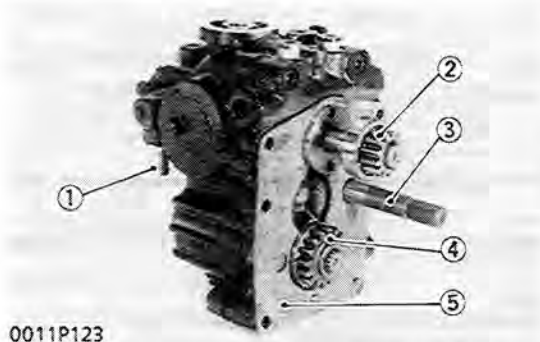

0011P123

- (1) Hose Joint
- (2) 13T Gear
- (3) Front Wheel Drive Shaft 1
- (4) 16T Gear
- (5) Gasket

**Front Wheel Drive Shaft 1 and Gears**

1. Pull out the front wheel drive shaft 1 (3) forward.
2. Remove the external snap ring and 13T gear (2).
3. Remove the external snap ring and 16T gear (4).
4. Remove the hose joint (1) and gasket (5).

**(When reassembling)**

- Install the snap ring with its rounded edge facing the gear or bearing so that its sharp edge in the groove keeps itself in place against the force.

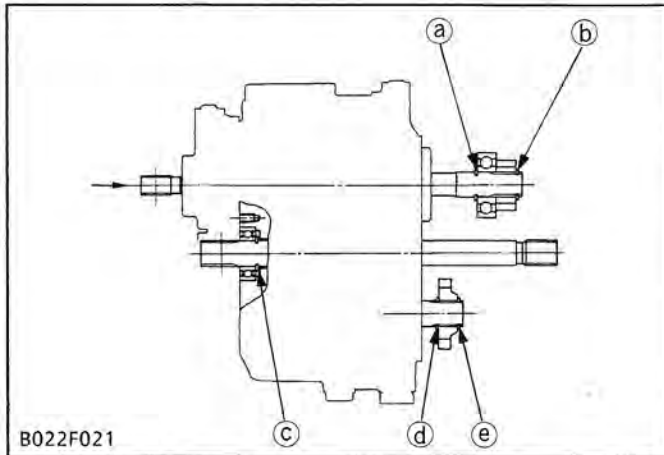

B022F021

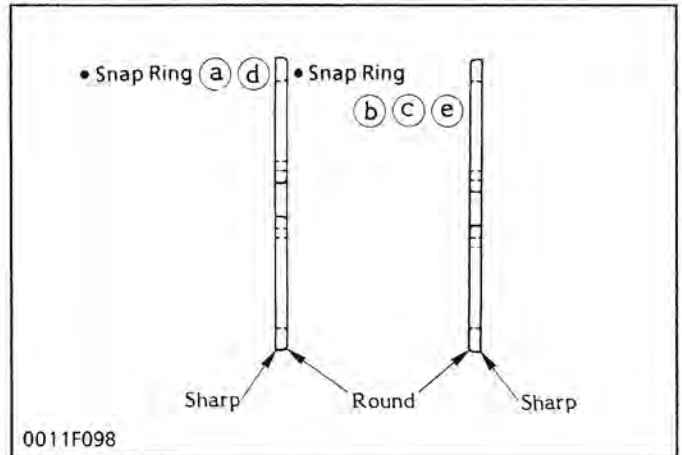

0011F098

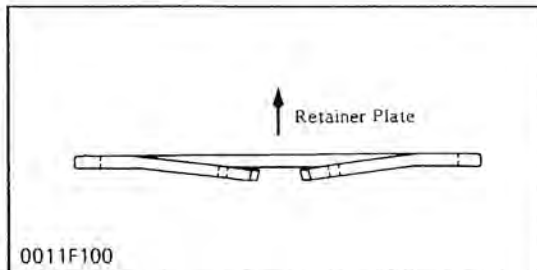

0011F100

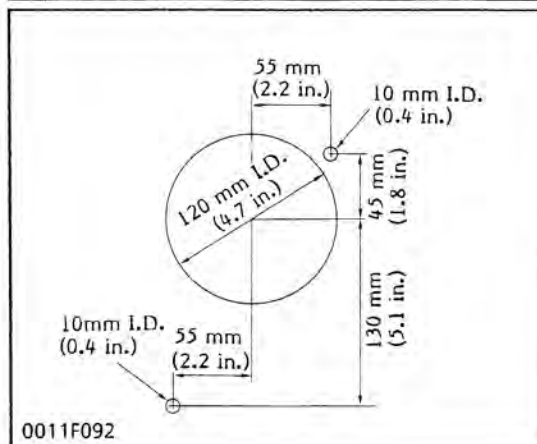

0011F092

**Repair-stand for Assembling and Disassembling**

1. To facilitate disassembling and assembling, make a repair stand as shown in the figure.

**IMPORTANT**

- Clean the repair-stand and the outside of the hydrostatic transmission case.
- Hydrostatic transmission is composed of many precision parts and they have highly finished or polished surface.
- Take extreme care to prevent damage or dirt during disassembling and assembling.
- Coat hands with hydrostatic transmission oil before handling the parts to minimize the possibility of rust.
- Clean the parts and coat them with hydrostatic transmission oil before assembling.



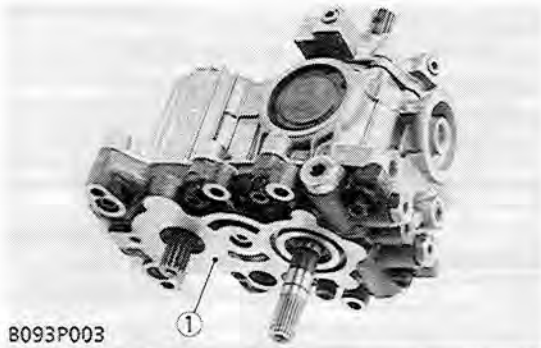

B093P003

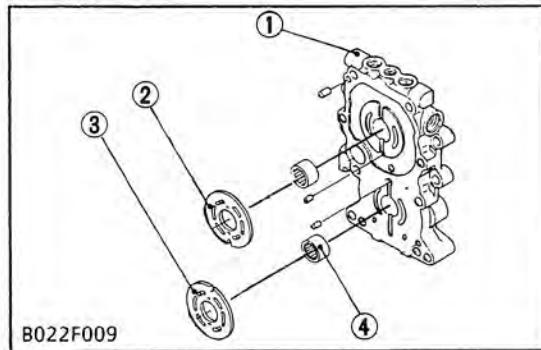

B022F009

**Port Block**

1. Remove the port block mounting screws, and tap the front of port block (1) with a soft hammer to separate from the case.

**(When reassembling)**

- Cover the splines of each shaft with thin tape to protect the sealing lip.
- Install port block with gasket, O-ring and valve plate in place.

**IMPORTANT**

- Valve plates (2), (3) may stick to the port block, but they are not fixed. Take care not to drop them.
- Valve plates are not interchangeable. Valve plate of the pump has two notches and the valve of the motor has no notches.

Tightening torque	Port block to case	48.1 to 55.9 N·m 4.9 to 5.7 kgf·m 35.4 to 41.2 ft·lbs
-------------------	--------------------	---

- (1) Port Block
- (2) Pump Valve Plate
- (3) Motor Valve Plate
- (4) Needle Bearing

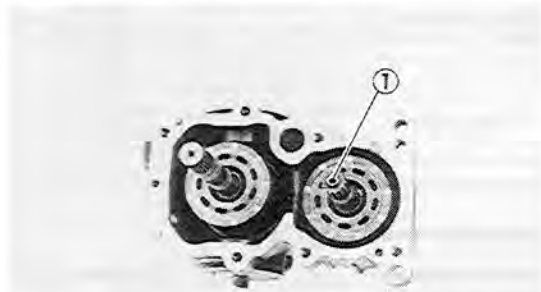

0011P147

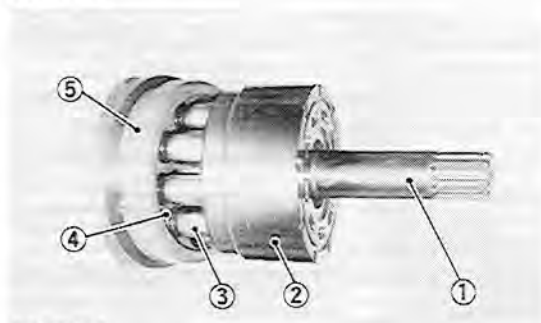

0306P003

**Motor Cylinder Block**

1. Hold the output shaft (1) and slightly tap the rear of case flange with a soft hammer to separate the motor cylinder block assembly.
2. Slide out the motor cylinder block (2) with pistons (3), retainer plate (4) and retainer holder (5).

**(When reassembling)**

- Aligning the hole on the swashplate to the dowel pin in the case, and install the output shaft assembly in the case.

- (1) Output Shaft
- (2) Motor Cylinder Block
- (3) Piston
- (4) Retainer Plate
- (5) Retainer Holder

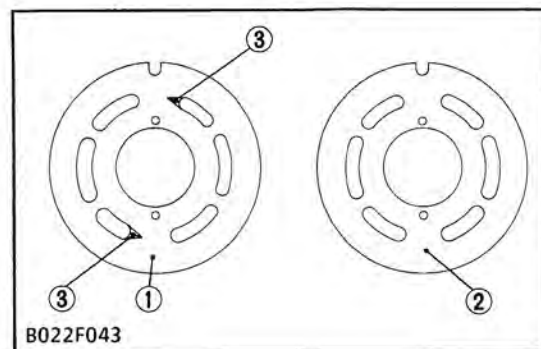

B022F043

**IMPORTANT**

- Valve plate of the pump (with two notches) should be mounted on the pump side of the port block.
- The notch side of pump valve plate should be directed to the side of the pump cylinder block.

- (1) Pump Valve Plate
- (2) Motor Valve Plate
- (3) Notch

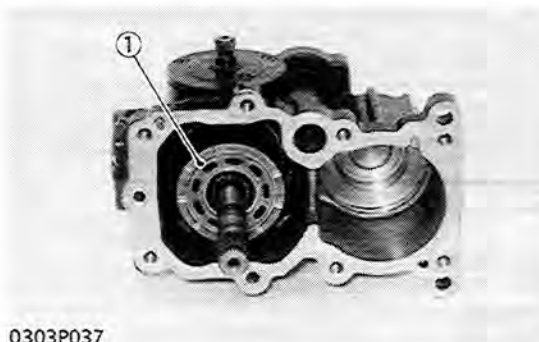

0303P037

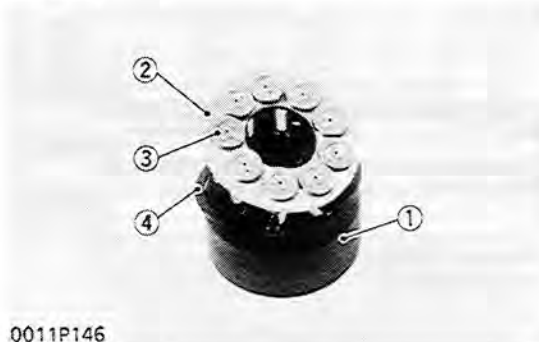

0011P146

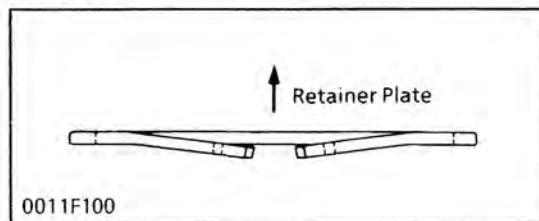

0011F100

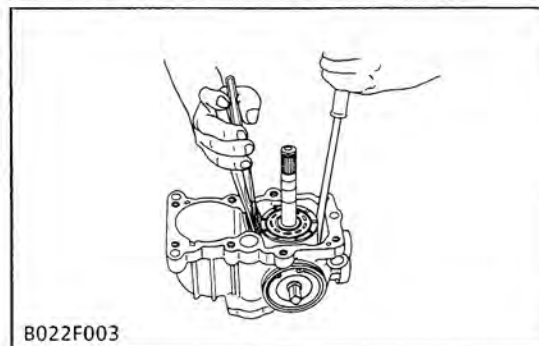

B022F003

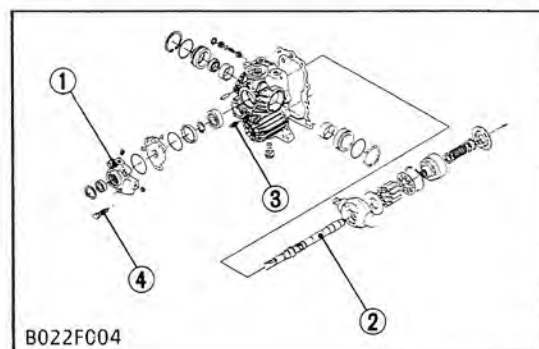

B022F004

**Pump Cylinder Block**

1. Remove the internal snap ring retaining the retainer plate of pump.
2. Slide out pump cylinder block (1) with pistons (3) retainer plate (2) and internal snap ring (4).
3. Draw out the thrust plate from the variable swashplate.

**(When reassembling)**

- Check that internal snap ring (4) faces correct in the direction, and install it to pump swashplate.
- Squeeze the snap ring (4) and slip into the hole its arc first by pushing down with a screwdriver to fit surely.

- (1) Pump Cylinder Block
- (2) Retainer Plate
- (3) Piston
- (4) Snap Ring

**Charge Pump and Input Shaft**

1. Remove the screws (4) for retaining the charge pump case (1).
2. Tapping the rear end of the input shaft (2) with a soft hammer, separate the charge pump case (1) with the input shaft (2) from the case.
3. Remove two dowel pins (3).

Tightening torque	Charge pump case to case	23.5 to 27.5 N·m 2.4 to 2.8 kgf·m 17.4 to 20.3 ft·lbs
-------------------	--------------------------	---

- (1) Charge Pump Case
- (2) Input Shaft
- (3) Dowel Pin
- (4) Screw

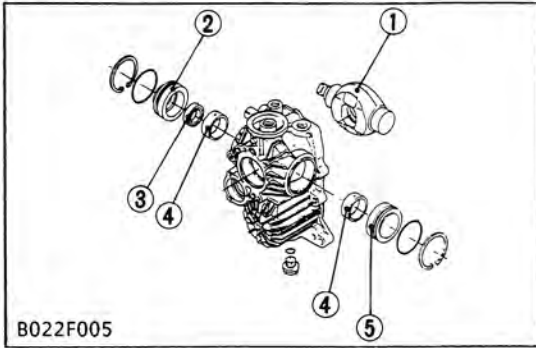

**Cover "A", "B" and Trunnion Shaft**

1. Remove the internal snap ring.
2. Tap the trunnion shaft (1) using a soft hammer to create a clearance between the case and the cover "A" (2). Then, pry the cover "A" (2) open with a screw-driver. Pry the cover "B" (5) in the same way.
3. Pull out the trunnion shaft (1).

- |                    |                     |
|--------------------|---------------------|
| (1) Trunnion Shaft | (4) Seam of Bearing |
| (2) Cover "A"      | (5) Cover "B"       |
| (3) Oil Seal       |                     |

**SERVICING**

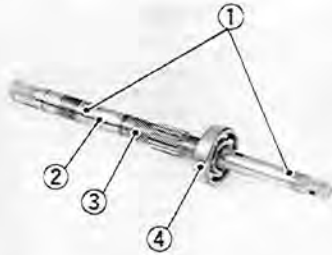

**Input Shaft**

1. Pull out input shaft (3) with the bearing on it from the charge pump case.
2. Check the seal surface (1), the bearing surface (2) and the bearing (4).
3. If the shaft is rough or grooved, replace.
4. If the bearing is worn, replace.

- |                     |                 |
|---------------------|-----------------|
| (1) Seal Surface    | (3) Input Shaft |
| (2) Bearing Surface | (4) Bearing     |

0011P132



**Cylinder Block Bore and Pistons**

1. Lift all the pistons gently with the retainer plate (1).
2. Check the pistons for their free movement in the cylinder block bores.
3. If the piston or the cylinder block bore is scored, replace the cylinder block assembly.

Clearance between piston and bore	Factory spec.	0.02 mm 0.0008 in.
-----------------------------------	---------------	-----------------------

- (1) Retainer Plate

0306P008

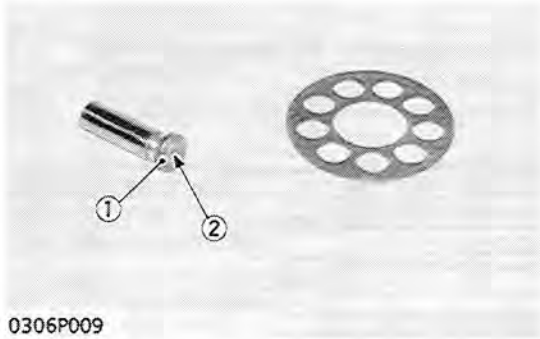

**Piston Slipper and Retainer Plate**

1. Check the slipper (1) for flatness.
2. If rounded, replace.
3. Measure the thickness of piston slipper.
4. If the measurement is less than the allowable limit, replace.
5. Check the lubricant hole (2) for clogging.
6. If clogged, open hole with compressed air.

Thickness of slipper	Factory spec.	3.00 mm 0.118 in.
	Allowable limit	2.90 mm 0.114 in.

(1) Piston Slipper (2) Lubricant Hole

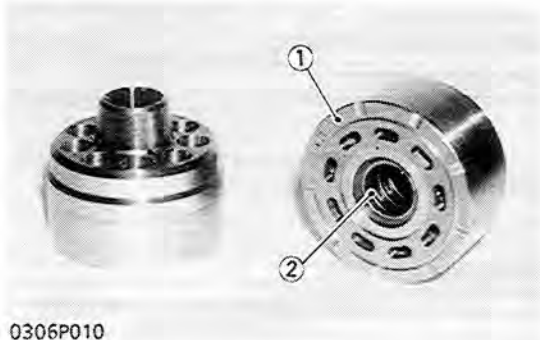

**Cylinder Block Face**

1. Check the polished face (1) of cylinder block for scoring.
2. If scored, replace the cylinder block assembly.
3. Check the spring (2) for breakage.
4. If broken, replace the cylinder block assembly.

(1) Polished Face (2) Spring

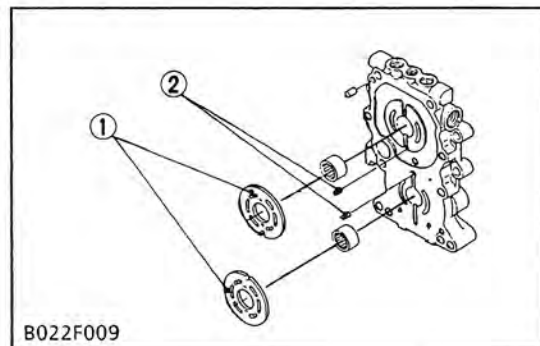

**Valve Plate**

1. Check the engagement of the valve plate (1) and the dowel pin (2).
2. Pushing the valve plate against the dowel pin, lift it to remove.
3. Check the valve plate for foreign particles.
4. Clean the valve plate and dry with compressed air.
5. Check the valve plate for scratches, wear and erosion.
6. If worn or scored, replace.

**NOTE**

- Run a fingernail across the valve plate surface. If worn, it will be felt. After checking, coat them with hydrostatic transmission oil.

(1) Valve Plate (2) Dowel Pin

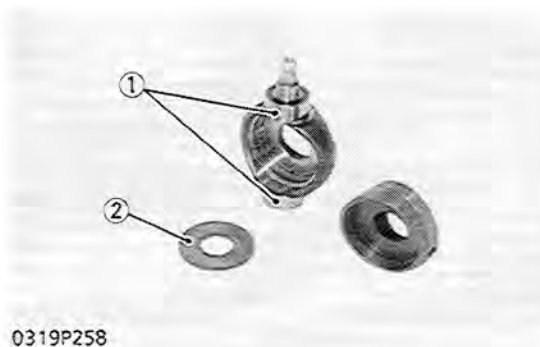

**Swashplate and Thrust Plate**

1. Check the bearing surface of trunnion shaft (1) for scratches and excessive wear.
2. If worn or scored, replace.
3. Check the thrust plate (2) for scratches and excessive wear.
4. If worn or scored, replace.

(1) Bearing Surface (2) Thrust Plate

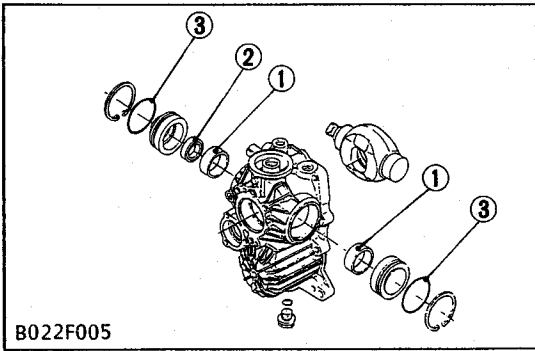

### Trunnion Shaft Cover

1. Check the bearings (1) for scratches and excessive wear.
2. If worn or scored, replace.
3. Check the oil seal (2) and the O-ring (3) for damage.

#### ■ NOTE

- After checking, coat the bearing with hydrostatic transmission oil, and the oil seal lip and the O-ring with grease.

- (1) Bearing  
(2) Oil Seal

- (3) O-ring

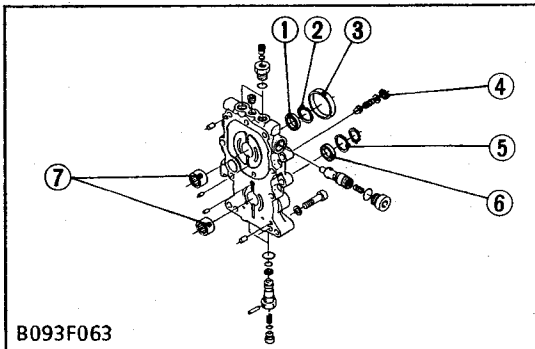

### Oil Seal and Bearing

1. Remove the collar (3) and internal snap ring (2), (5) and check the oil seals (1), (6) for damage.
2. Check the bearings (7) for wear.
3. If the bearings are worn, replace.

#### ■ NOTE

- After checking, coat the bearing with hydrostatic transmission oil and the oil seal lip with grease.
- When replacing the bearing, press it in the port block so that its mark faces outside and 3.5 mm (0.318 in.) of it remains above the machined surface.
- When reassembling, always replace the oil seal as follows.

- (1) Oil Seal  
(2) Internal Snap Ring  
(3) Collar  
(4) Internal Snap Ring

- (5) Internal Snap Ring  
(6) Oil Seal  
(7) Needle Bearing

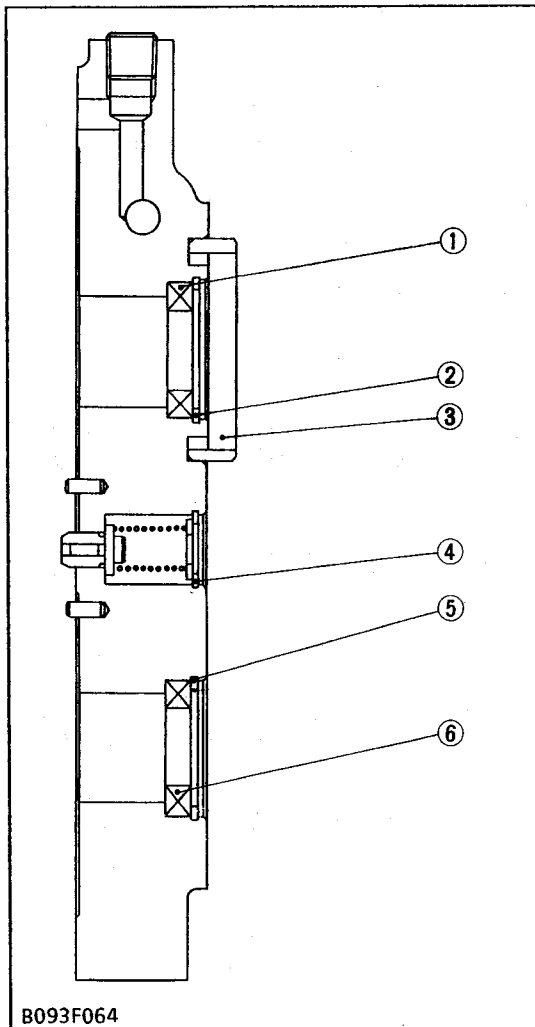

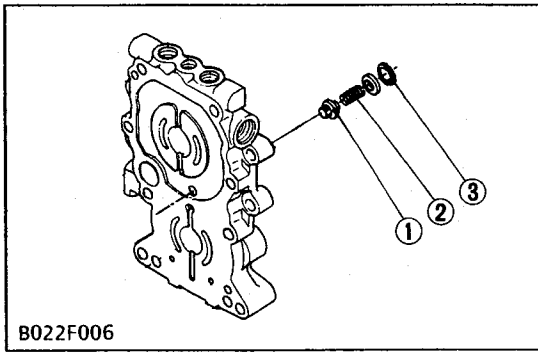

**Case Relief Valve**

1. Check the valve and the spring for excessive wear and breakage.
2. If worn or broken, replace.

Length of valve spring	Factory spec.	23.0 mm, 0.906 in. (free)
		15.0 mm, 0.591 in. (load 29.4 N, 3.00 kgf, 6.62 lbs)

- (1) Case Relief Valve (2) Spring (3) Internal Snap Ring

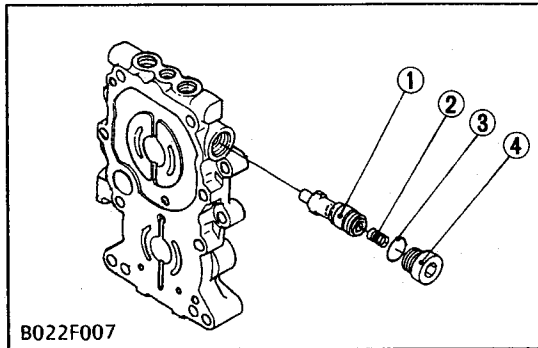

**Check and High Pressure Relief Valve**

1. Check the valve (1) for scratches and damage.
2. Check the valve seat in the port block for damage.
3. Check the spring (2) for breakage and wear.
4. If anything unusual, replace the check and high pressure relief valve complete assembly.

Length of valve spring	Factory spec.	18.2 mm, 0.717 in. (free)
		14.5 mm, 0.571 in. (load 3.43 N, 0.35 kgf, 0.77 lbs)
Length of valve spring	Factory spec.	12.4 mm, 0.488 in. (free)
		10.5 mm, 0.413 in. (load 41.87 N, 4.27 kgf, 9.41 lbs)
Tightening torque	Cap nut	53.9 to 63.7 N·m 5.5 to 6.5 kgf·m 39.8 to 47.0 ft·lbs

- (1) Valve (2) Spring (3) O-ring (4) Cap Nut

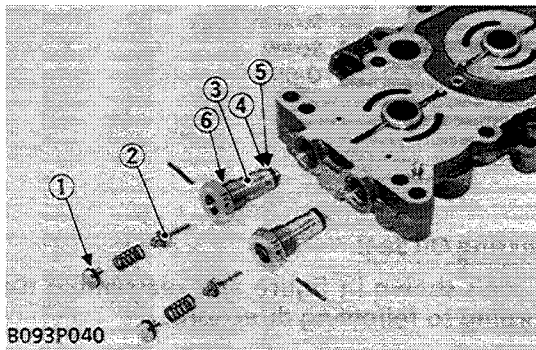

**Neutral Valve**

1. Remove the valve assembly and disassemble it.
2. Check the neutral valve (2) for their free movement on or in the valve body (3).
3. If the valve surface is scored, replace.
4. Check the holes of the valve body (3) and the neutral valve (2) for clogging.
5. If clogged, open hole with compressed air.
6. Check the O-rings (1), (5) and the backup ring (4) for scratches and damage.
7. Check the springs for breakage and wear.
8. If anything unusual, replace.

- (1) O-ring (2) Neutral Valve (3) Valve Body (4) Backup Ring (5) O-ring (6) O-ring

Length of valve spring	Factory spec.	18.4 mm, 0.7244 in. (free)
		13.9 mm, 0.5472 in. (load 43.2 N, 4.4 kgf, 9.7 lbs)

**NOTE**

- When reassembling, replace the O-ring and the backup rings.

Tightening torque	Valve body to case	53.9 to 63.7 N·m 5.5 to 6.5 kgf·m 39.8 to 47.0 ft·lbs
-------------------	--------------------	---

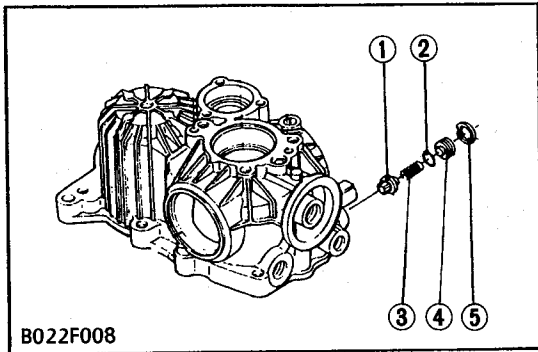

B022F008

- (1) Valve
- (2) O-ring
- (3) Spring
- (4) Spring Holder
- (5) Internal Snap Ring

**Charge Relief Valve**

1. Remove the internal snap ring (5) and draw out the spring holder (4).
2. Check the spring (3) for breakage and wear.
3. Check the O-ring (2) for damage.
4. If anything unusual, replace.

■ **NOTE**

- Install the internal snap ring with its sharp edge facing outside.

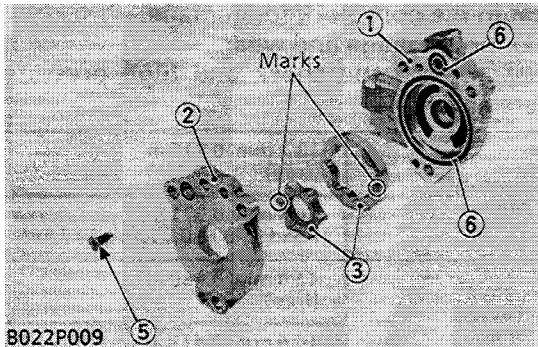

B022P009

**Charge Pump**

1. Check the charge pump case (1), the plate (2) and the gerotor set (3) for scratches and wear.
2. If scratched or worn, replace the charge pump complete assembly.
3. Measure the side clearance referring to the figure.
4. If the clearance exceeds the factory specification, replace the charge pump complete assembly.

Side clearance	Factory spec.	0.030 to 0.060 mm 0.0018 to 0.0236 in.
----------------	---------------	---

■ **NOTE**

- When reassembling, replace the O-rings (6) and the oil seals, and grind the surface of the plate (2) and the charge pump case (1) with finest oil stone.

- (1) Charge Pump Case
- (2) Plate
- (3) Gerotor Set
- (4) Straight Edge
- (5) Screw
- (6) O-ring

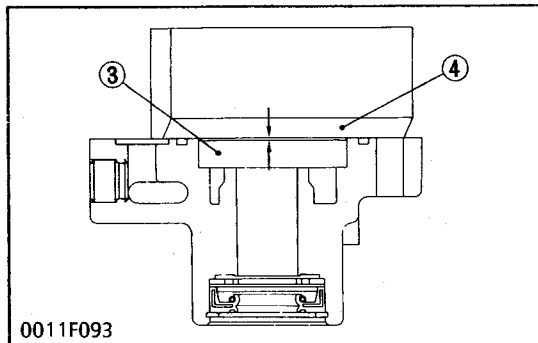

0011F093

**Special Tool A for Pressing Oil Seal**

1. Make the special tools shown in figure and reassemble the charge pump according to following directions.

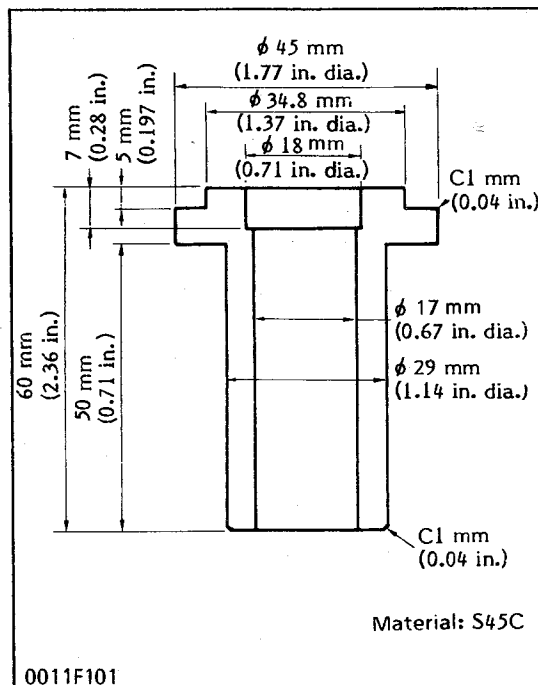

0011F101

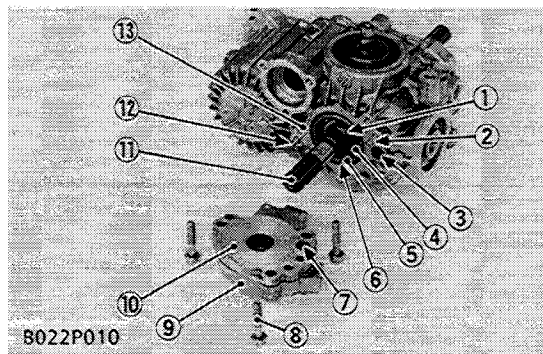

### Reassembling

1. Place the swashplate in neutral and install the input shaft (11) to the case (13) with the bearing (4) on it.
2. Install the collar (5) on the bearing (4).
3. Coat the O-rings (3), (6) with hydrostatic transmission oil and install them on the case (13).
4. Install the dowel pins (2), (12).
5. Press the oil seal in the charge pump case, using the special tool A, until it is 4 mm (0.157 in.) below the machined surface.
6. Install the internal snap ring with its sharp edge facing outside.
7. Coat the O-rings with hydrostatic transmission oil and install them on the charge pump case (9).
8. Install the gerotor set on the charge pump case and set the plate (10) to it.
9. Set the screw (7) and tighten it, aligning each hole on the plate to each hole on the charge pump case, each other.
10. Install this charge pump assembly to the input shaft, aligning the gerotor splines to the shaft splines and two holes to two dowel pins.
11. Tighten three screws (8).

Tightening torque	Charge pump case to case	23.5 to 27.5 N·m 2.4 to 2.8 kgf·m 17.4 to 20.3 ft·lbs
-------------------	--------------------------	---

- |                        |                      |
|------------------------|----------------------|
| (1) External Snap Ring | (8) Screw            |
| (2) Dowel Pin          | (9) Charge Pump Case |
| (3) O-ring             | (10) Plate           |
| (4) Bearing            | (11) Input Shaft     |
| (5) Collar             | (12) Dowel Pin       |
| (6) O-ring             | (13) Case            |
| (7) Screw              |                      |





---

**EDITOR:**

KUBOTA FARM & INDUSTRIAL MACHINERY SERVICE, LTD.

64, ISHIZU-KITAMACHI, SAKAI-KU, SAKAI-CITY, OSAKA, 590-0823, JAPAN

PHONE : (81)72-241-1129

FAX : (81)72-245-2484

E-mail : ksos-pub@kubota.co.jp

---