

8 FRONT LOADER

SAFETY DECALS

The following safety decals are installed on the machine.

If a decal becomes damaged, illegible or is not on the machine, replace it. The decal part number is listed in the parts list.

(1) Part No. 7J246-5643-1

⚠ DANGER



TO AVOID SERIOUS INJURY OR DEATH CAUSED BY FALLING LOADS :

1. Load on raised bucket or fork can fall or roll back onto operator causing serious injury or death.
2. Use approved clamping and / or guard attachments for handling large, loose or shiftable loads such as bales, posts, sheets of plywood etc.
3. Carry loads as low as possible.

1AIABAHAP016A

(2) Part No. 7J246-5645-1

⚠ CAUTION

TO AVOID PERSONAL INJURY :

1. Observe safety precautions in loader and tractor Operator's Manual.
2. Operate the loader from tractor seat only.
3. Keep children, others and livestock away when operating loader and tractor.
4. Avoid holes, loose ground, and rocks which may cause tractor / loader to tip.
5. Make sure approved bucket is attached before removing loader from tractor.
6. When parking or storing, choose flat and hard ground. Lower the bucket to the ground, set brakes and remove key before leaving tractor.
7. Before disconnecting hydraulic lines, relieve all hydraulic pressure.

1AIABAHAP019A

(3) Part No. 7J246-5642-1

⚠ DANGER

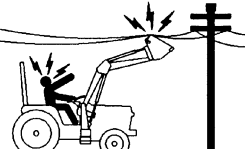

TO AVOID SERIOUS INJURY OR DEATH CAUSED BY CONTACT WITH ELECTRIC LINES:

- Check overhead clearance.

1AIABAHAP018A

(5) Part No. 7J246-5644-2
(Both sides)

⚠ WARNING



TO AVOID INJURY FROM FALLS OR BEING CRUSHED :

1. DO NOT stand or work under raised loader or bucket.
2. DO NOT use loader as jack for servicing.
3. DO NOT use loader as a work platform.
4. NEVER connect chain, cable or rope to loader bucket while operating loader.

1AIABAHAP020A

(4) Part No. 7J266-5649-2

⚠ CAUTION

TO AVOID INJURY FROM CRUSHING :

1. Do not utilize the valve lock for machine maintenance or repair.
2. The valve lock is to prevent accidental actuation when implement is not in use or during transport.

1AIABACAP077A

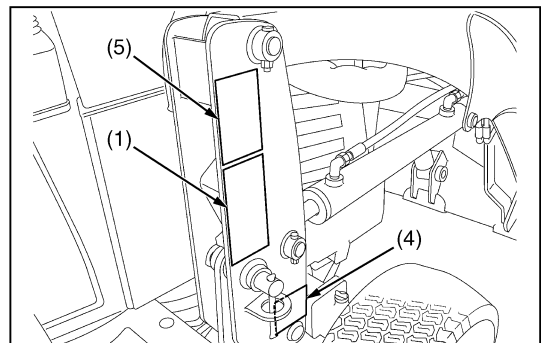
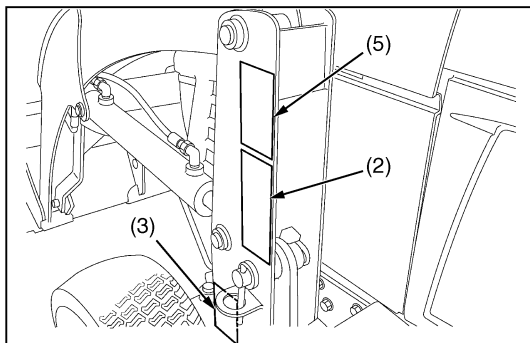

3TAAAAICP002A

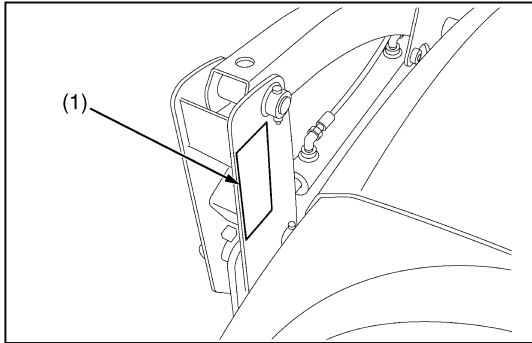

(1) Part No. 7J246-5641-1



1A1ABAHAP017A

CARE OF DANGER, WARNING AND CAUTION LABELS

1. Keep danger, warning and caution labels clean and free from obstructing material.
2. Clean danger, warning and caution labels with soap and water, dry with a soft cloth.
3. Replace damaged or missing danger, warning and caution labels with new labels.
4. If a component with danger, warning or caution label(s) affixed is replaced with new part, make sure new label(s) is (are) attached in the same locations(s) as the replaced component.
5. Mount new danger, warning and caution labels by applying on a clean dry surface and pressing any bubbles to outside edge.

3TAAAAICP003A

SPECIFICATIONS

■ Loader Specifications

Loader model		LA203	LA243
Tractor model		BX1860	BX2360, BX2660
Wheel base (WB)		1340 mm (52.8 in.)	1400 mm (55.1 in.)
Front tires		16 x 7.5-8	18 x 8.5-10
Rear tires		24 x 12-12	26 x 12-12
Boom cylinder	Bore	40 mm (1.57 in.)	
	Stroke	281 mm (11.1 in.)	326 mm (12.8 in.)
Bucket cylinder	Bore	65 mm (2.56 in.)	
	Stroke	204 mm (8.03 in.)	
Control valve		One detente float position, two stage bucket dump, power beyond circuit	
Rated flow		14 L/min. (3.7 U.S.gals/min., 3.1 Imp.gals/min.)	
Maximum pressure		12.3 MPa (125 kgf/cm ² , 1778 psi)	
Net weight (Approximate)		157 kg (346 lbs)	170 kg (375 lbs)

W1027852

■ Bucket Specifications

Loader model		LA203	LA243
Model		Square 48"	
Type		Rigid	
Width		1219 mm (48.0 in.)	
Depth (L)		455 mm (17.9 in.)	495 mm (19.5 in.)
Height (M)		445 mm (17.5 in.)	465 mm (18.3 in.)
Length (N)		498 mm (19.6 in.)	538 mm (21.2 in.)
Capacity	Struck	0.12 m ³ (4.2 CU.FT.)	0.14 m ³ (4.9 CU.FT.)
	Heaped	0.14 m ³ (4.9 CU.FT.)	0.17 m ³ (6.1 CU.FT.)
Weight		56 kg (123 lbs)	60 kg (132 lbs)

W1030245

■ Dimensional Specifications

Loader Model		LA203	LA243
	Tractor model	BX1860	BX2350, BX2660
A	Max. lift height (To bucket pivot pin)	1810 mm (71.3 in.)	
B	Max. lift height under level bucket	1680 mm (66.1 in.)	
C	Clearance with bucket dumped	1350 mm (53.1 in.)	1330 mm (52.4 in.)
D	Reach at max. lift height (Dumping reach)	720 mm (28.3 in.)	735 mm (28.9 in.)
E	Max. dump angle	40 deg. (0.784 rad)	45 deg. (0.785 rad)
F	Reach with bucket on ground	1330 mm (52.4 in.)	1390 mm (54.7 in.)
G	Bucket roll-back angle	30 deg. (0.59 rad)	29 deg. (0.51 rad)
H	Digging depth	100 mm (3.9 in.)	120 mm (4.7 in.)
I	Overall height in carrying position	970 mm (38.2 in.)	990 mm (39.0 in.)

W1028417

Operational Specifications

Loader Model		LA203	LA243
Tractor model		BX1860	BX2350, BX2660
Lift capacity to max. height (Bucket bottom mid point)		200 kg (441 lbs)	240 kg (529 lbs)
U	Lift capacity (Bucket pivot pin, max. height)	280 kg (617 lbs)	340 kg (750 lbs)
V	Lift capacity (500 mm forward, max. height)	185 kg (408 lbs)	235 kg (518 lbs)
W	Lift capacity (Bucket pivot pin, 1500 mm (59 in.) height)	315 kg (694 lbs)	375 kg (827 lbs)
X	Lift capacity (1500 mm height)	220 kg (485 lbs)	270 kg (595 lbs)
Y	Breakout force (Bucket pivot pin)	5720 N (1287 lbs)	6290 N (1415 lbs)
Z	Breakout force (500 mm forward)	3920 N (882 lbs)	4410 N (992 lbs)
VV	Bucket roll-back force at max. height	4460 N (1003 lbs)	4750 N (1069 lbs)
XX	Bucket roll-back force at 1.5M (5.9 in.)	5380 N (1210 lbs)	5600 N (1260 lbs)
ZZ	Bucket roll-back force at ground level	5580 N (1255 lbs)	5490 N (1235 lbs)
Raising time		2.8 sec.	3.5 sec.
Lowering time		2.0 sec.	2.7 sec.
Bucket dumping time		1.8 sec.	1.7 sec.
Bucket rollback time		2.1 sec.	2.4 sec.

W1030633

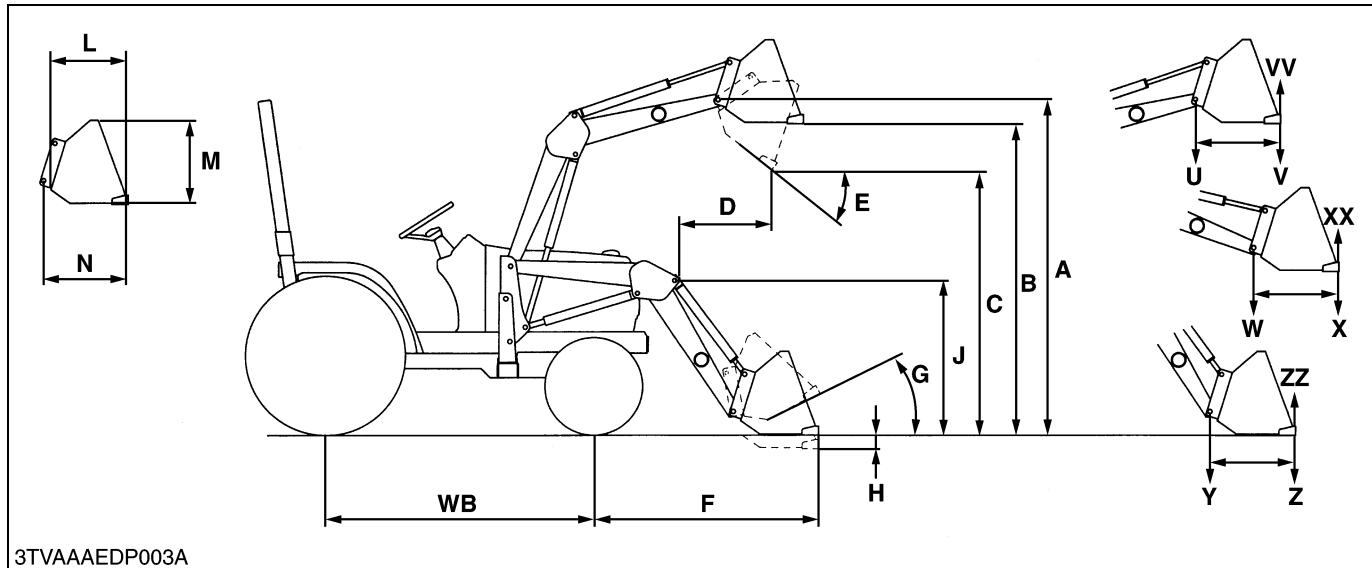

GENERAL

CONTENTS

1. IDENTIFICATION.....	8-G1
2. GENERAL PRECAUTION	8-G2
3. LUBRICANTS	8-G3
4. TIGHTENING TORQUES	8-G4
[1] GENERAL USE SCREWS, BOLTS AND NUTS (FOR FRONT LOADER AND BACKHOE).....	8-G4
[2] STUD BOLTS.....	8-G4
[3] AMERICAN STANDARD SCREWS, BOLTS AND NUTS WITH UNC OR UNF THREADS	8-G5
[4] PLUGS.....	8-G5
[5] HYDRAULIC FITTINGS.....	8-G6
[6] TIGHTENING TORQUES OF SCREWS, BOLTS AND NUTS ON THE TABLE BELOW ARE ESPECIALLY SPECIFIED	8-G6
5. MAINTENANCE CHECK LIST.....	8-G7
6. CHECK AND MAINTENANCE.....	8-G8
[1] CHECK POINTS OF EACH USE OR DAILY.....	8-G8
[2] CHECK POINTS OF EVERY 10 HOURS.....	8-G8
7. DISMOUNTING AND MOUNTING FRONT LOADER FROM TRACTOR	8-G9
[1] DISMOUNTING FRONT LOADER FROM TRACTOR	8-G9
[2] MOUNTING FRONT LOADER TO TRACTOR.....	8-G10

1. IDENTIFICATION

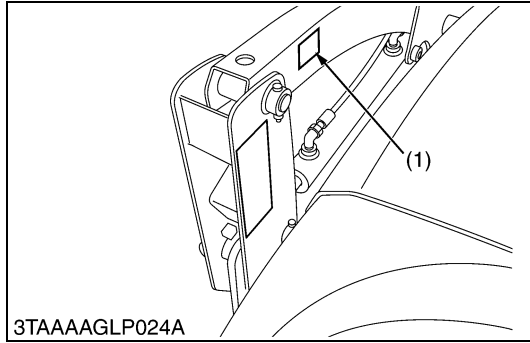

3TAAAAGLP024A

When contacting your local KUBOTA distributor, always specify front loader model and serial number.

(1) Model / Serial Number

W1010468

2. GENERAL PRECAUTION

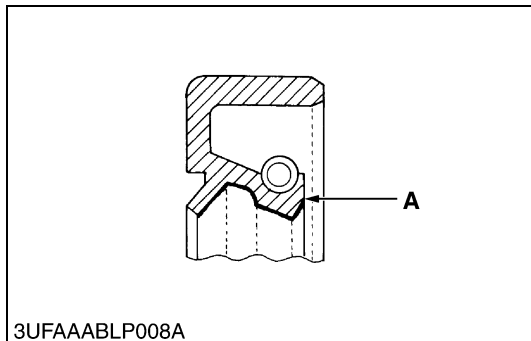

- During disassembly, carefully arrange removed parts in a clean area to prevent later confusion. Screws, bolts and nuts should be replaced in their original positions to prevent reassembly errors.
- When special tools are required, use genuine KUBOTA tools. Special tools which are not used frequently should be made according to the drawings provided.
- Clean parts before measuring them.
- Use only genuine KUBOTA parts for parts replacement to maintain loader performance and to assure safety.
- O-ring and oil seals must be replaced during reassembly. Apply grease to new O-rings or oil seals before reassembling.

A : Grease

W1010531

3. LUBRICANTS

To prevent serious damage to hydraulic system, use only specified fluid or its equivalent.

Place	Capacities	Lubricants
Transmission Case	11.6 L 3.1 U.S.gals 2.6 Imp.gals	KUBOTA SUPER UDT Fluid *
Grease fitting	Until grease overflows	Moly Ep Type grease

■ **NOTE**







- * **KUBOTA SUPER UDT Fluid**.....KUBOTA original transmission hydraulic fluid

W1010650

4. TIGHTENING TORQUES

[1] GENERAL USE SCREWS, BOLTS AND NUTS (FOR FRONT LOADER AND BACKHOE)

Screws, bolts, and nuts whose tightening torques are not specified in this Workshop Manual should be tightened according to the table below.

Indication on top of bolt	  No-grade or 4T						  7T or Property class 8.8						  9T or Property class 10.9			
	Material of opponent part	Ordinariness			Aluminum			Ordinariness			Aluminum			Ordinariness		
Diameter	Unit	N·m	kgf·m	lbf·ft	N·m	kgf·m	lbf·ft	N·m	kgf·m	lbf·ft	N·m	kgf·m	lbf·ft	N·m	kgf·m	lbf·ft
M6 (6 mm, 0.24 in.)		7.9	0.80	5.8	7.9	0.80	5.8	9.81	1.00	7.24	7.9	0.80	5.8	12.3	1.25	9.05
		to 9.3	to 0.95	to 6.8	to 8.8	to 0.90	to 6.5	to 11.2	to 1.15	to 8.31	to 8.8	to 0.90	to 6.5	to 14.2	to 1.45	to 10.4
M8 (8 mm, 0.31 in.)		18	1.8	13	17	1.7	13	24	2.4	18	18	1.8	13	30	3.0	22
		to 20	to 2.1	to 15	to 19	to 2.0	to 14	to 27	to 2.8	to 20	to 20	to 2.1	to 15	to 34	to 3.5	to 25
M10 (10 mm, 0.39 in.)		40	4.0	29	32	3.2	24	48	4.9	36	40	4.0	29	61	6.2	45
		to 45	to 4.6	to 33	to 34	to 3.5	to 25	to 55	to 5.7	to 41	to 44	to 4.5	to 32	to 70	to 7.2	to 52
M12 (12 mm, 0.47 in.)		63	6.4	47	-	-	-	78	7.9	58	63	6.4	47	103	10.5	76.0
		to 72	to 7.4	to 53	-	-	-	to 90	to 9.2	to 66	to 72	to 7.4	to 53	to 117	to 12.0	to 86.7
M14 (14 mm, 0.55 in.)		108	11.0	79.6	-	-	-	124	12.6	91.2	-	-	-	167	17.0	123
		to 125	to 12.8	to 92.5	-	-	-	to 147	to 15.0	to 108	-	-	-	to 196	to 20.0	to 144
M16 (16 mm, 0.63 in.)		167	17.0	123	-	-	-	197	20.0	145	-	-	-	260	26.5	192
		to 191	to 19.5	to 141	-	-	-	to 225	to 23.0	to 166	-	-	-	to 304	to 31.0	to 224
M18 (18 mm, 0.71 in.)		246	25.0	181	-	-	-	275	28.0	203	-	-	-	344	35.0	254
		to 284	to 29.0	to 209	-	-	-	to 318	to 32.5	to 235	-	-	-	to 402	to 41.0	to 296
M20 (20 mm, 0.79 in.)		334	34.0	246	-	-	-	368	37.5	272	-	-	-	491	50.0	362
		to 392	to 40.0	to 289	-	-	-	to 431	to 44.0	to 318	-	-	-	to 568	to 58.0	to 419



W1034542

[2] STUD BOLTS

Material of opponent part	Ordinariness			Aluminum			
Diameter	Unit	N·m	kgf·m	lbf·ft	N·m	kgf·m	lbf·ft
M8 (8 mm, 0.31 in.)		12	1.2	8.7	8.9	0.9	6.5
		to 15	to 1.6	to 11	to 11	to 1.2	to 8.6
M10 (10 mm, 0.39 in.)		25	2.5	18	20	2.0	15
		to 31	to 3.2	to 23	to 25	to 2.6	to 18
M12 (12 mm, 0.47 in.)		29.5	3.0	21.7	-	-	-
		to 49.0	to 5.0	to 36.1	31.4	3.2	23.1
M14 (14 mm, 0.55 in.)		62	6.3	46	-	-	-
		to 73	to 7.5	to 54	-	-	-
M16 (16 mm, 0.63 in.)		98.1	10.0	72.4	-	-	-
		to 112	to 11.5	to 83.1	-	-	-
M18 (18 mm, 0.71 in.)		172	17.5	127	-	-	-
		to 201	to 20.5	to 148	-	-	-



W1048139

[3] AMERICAN STANDARD SCREWS, BOLTS AND NUTS WITH UNC OR UNF THREADS

Grade	SAE GR.5 			SAE GR.8 			
	Unit	N-m	kgf-m	lbf-ft	N-m	kgf-m	lbf-ft
Nominal Diameter							
1/4	11.7 to 15.7	1.19 to 1.61	8.61 to 11.6	16.3 to 19.7	1.66 to 2.01	12.0 to 14.6	
5/16	23.1 to 27.7	2.35 to 2.83	17.0 to 20.5	33 to 39	3.4 to 4.0	24 to 29	
3/8	48 to 56	4.9 to 5.8	35.0 to 42.0	61 to 73	6.3 to 7.4	45 to 54	
1/2	110 to 130	11 to 13	80 to 96	150 to 178	15.2 to 18.2	110 to 132	
9/16	150 to 178	15.2 to 18.2	110 to 132	217 to 260	22.2 to 26.5	160 to 192	
5/8	204 to 244	20.8 to 24.8	150 to 180	299 to 357	30.5 to 36.4	220 to 264	

W1022485

[4] PLUGS

Shape	Size	Material of opponent part					
		Ordinariness			Aluminum		
		N-m	kgf-m	lbf-ft	N-m	kgf-m	lbf-ft
Tapered screw 	R1/8	13 to 21	1.3 to 2.2	9.4 to 15	13 to 21	1.3 to 2.0	9.4 to 15
	R1/4	25 to 44	2.5 to 4.5	18 to 32	25 to 34	2.5 to 3.5	18 to 25
	R3/8	49 to 88	5.0 to 9.0	37 to 65	49 to 58	5.0 to 6.0	37 to 43
	R1/2	58.9 to 107	6.00 to 11.0	43.4 to 79.5	59 to 78	6.0 to 8.0	44 to 57
Straight screw 	G1/4	25 to 34	2.5 to 3.5	18 to 25	-	-	-
	G3/8	62 to 82	6.3 to 8.4	46 to 60	-	-	-
	G1/2	49 to 88	5.0 to 9.0	37 to 65	-	-	-

0000001666E

[5] HYDRAULIC FITTINGS

■ Adaptors, Elbows and Others

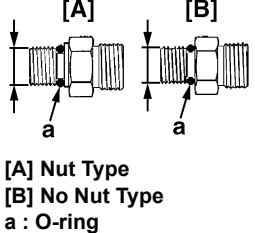
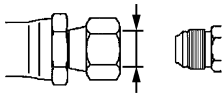
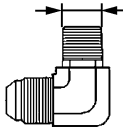
Item	Shape	Thread size	Tightening torque		
			N·m	kgf·m	lbf·ft
Adjustable elbow, Adaptor (O-ring port) (UNF)	 <p>[A] Nut Type [B] No Nut Type a : O-ring</p>	9/16	37 to 44	3.8 to 4.5	27 to 33
		3/4	48 to 54	4.9 to 5.5	35 to 40
		7/8	77 to 85	7.9 to 8.6	57 to 62
Hose fitting, Flare nut (UNF)		9/16	22 to 25	2.3 to 2.6	16 to 19
		3/4	36 to 40	3.6 to 4.1	26 to 30
		7/8	43 to 50	4.4 to 5.0	32 to 36
Adaptor (NPT)		1/4	30 to 50	3.1 to 5.0	23 to 36
		3/8	39 to 60	4.0 to 6.1	29 to 44
		1/2	49 to 58	5.0 to 5.9	36 to 43

■ NOTE

- When connecting a hose with flare nut, after tightening the nut with specified torque, return it approximately 45 degrees (0.79 rad) and re-tighten it to specified torque.

W1015484

[6] TIGHTENING TORQUES OF SCREWS, BOLTS AND NUTS ON THE TABLE BELOW ARE ESPECIALLY SPECIFIED

Item	N·m	kgf·m	ft-lbs
Boom cylinder piston mounting nut	150 to 180	15.3 to 18.3	111 to 132
Bucket cylinder piston mounting nut	350 to 400	35.7 to 40.7	259 to 295
Main frame mounting bolt and nut (M14)	147	15.0	108

W1012736

5. MAINTENANCE CHECK LIST

To keep the machine working in good condition as well as to avoid any accident and trouble, carry out periodic inspection and maintenance. Check the following points before use.

Service Interval	Check Points	Reference Page
Daily (Each use)	Check the transmission fluid level	8-G8
	Check the hydraulic hoses	8-G8
Every 10 hours	Grease all grease fitting	8-G8
	Lubricate joints of control lever linkage	8-G8

W1010764

6. CHECK AND MAINTENANCE

CAUTION

- When checking and repairing, park the tractor on flat ground and apply the parking brake.
- When checking and repairing, lower the bucket and stop the engine.

[1] CHECK POINTS OF EACH USE OR DAILY

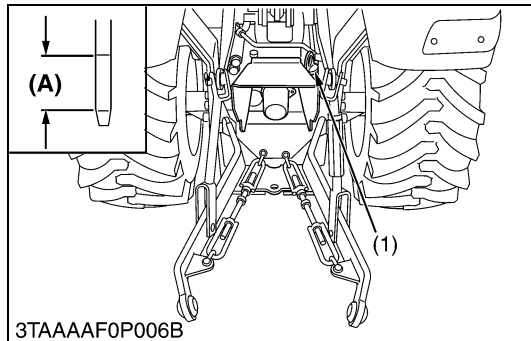

Checking Transmission Fluid Level

1. Check the oil level at the dipstick (1).
2. If the level is too low, add new oil to the prescribed level at the oil inlet.

■ IMPORTANT

- If oil level is low, do not run engine.

(1) Dipstick

A : Oil level is acceptable within this range.

W1010960

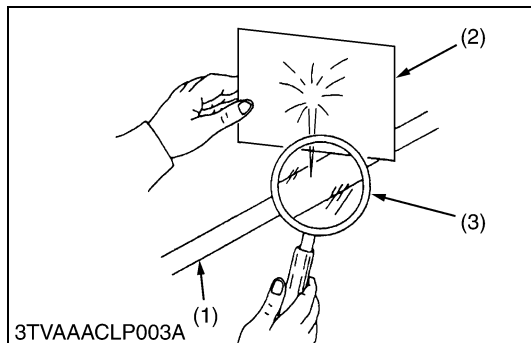

Checking Hydraulic Hoses

1. Checking all hydraulic hoses for cuts or wear.
2. If defects are found, replace them.

(1) Hydraulic Hose

(3) Magnifying Glass

(2) Cardboard

W1011064

[2] CHECK POINTS OF EVERY 10 HOURS

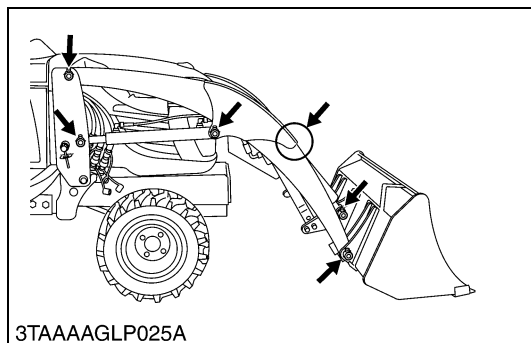

Greasing

1. Inject grease in all grease fitting with a hand grease gun.

W1011132

Lubricating

1. Lubricate joints of control lever linkage.

W1011274

7. DISMOUNTING AND MOUNTING FRONT LOADER FROM TRACTOR

■ IMPORTANT

- When dismantling the loader, park the tractor on flat and hard ground, apply the parking brake.
- When starting the engine or using the hydraulic control valve, always sit in the operator's seat.

[1] DISMOUNTING FRONT LOADER FROM TRACTOR

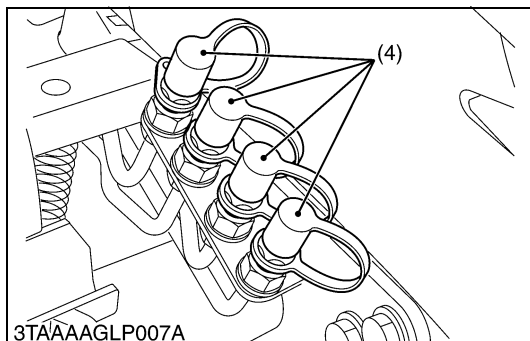
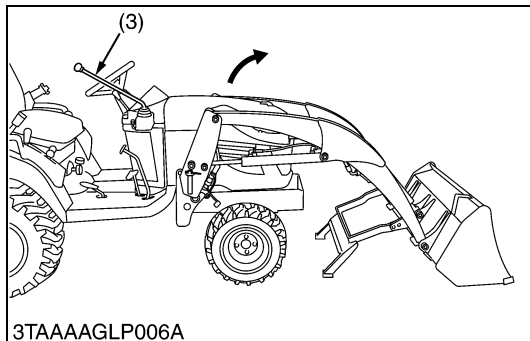
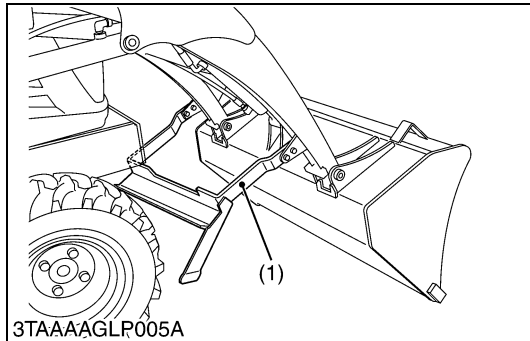
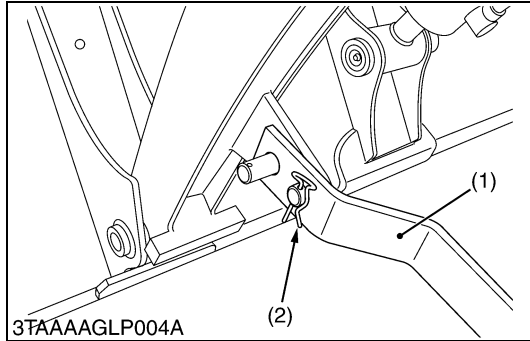

Side Frame

1. Raise the boom until the stands (1) can be rotated.
2. Stop the engine.
3. Remove the spring pin (2) holding the stand (1) to the boom.
4. Slide the stands (1) leftward and rotate it until the hole in the stand and pin on the boom are aligned. Then slide the stand (1) rightward and insert the spring pin (2) as shown.
5. Start the engine and run at idle.
6. Dump the bucket approximately 20 degrees.
7. Lower the boom and raise the front wheels slightly.

■ IMPORTANT

- **Lift the front wheels with the bucket. Do not attempt to lift the with the stand.**
8. Stop the engine.
 9. Remove the mounting pins from the loader side frames and hold them in the plate of side frame.
 10. Start the engine and run at idle. Slowly move the hydraulic control lever (3) to rollback position to raise the loader side frames up and out of the receives of the main frames as shown.
 11. Stop the engine.
 12. Slowly release all hydraulic pressure by moving the hydraulic control lever (3) in all directions.
 13. Disconnect the four hoses with quick couplers at the control valve and place them on the right side of the boom.
 14. Place the protective caps and plugs (4) on the quick coupler ends.
 15. Start the engine and slowly back the tractor away from the loader.

- (1) Stand
(2) Spring Pin

- (3) Hydraulic Control Lever
(4) Protective Plug

W1012789

[2] MOUNTING FRONT LOADER TO TRACTOR

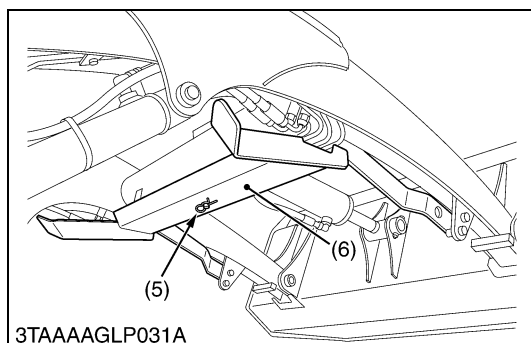
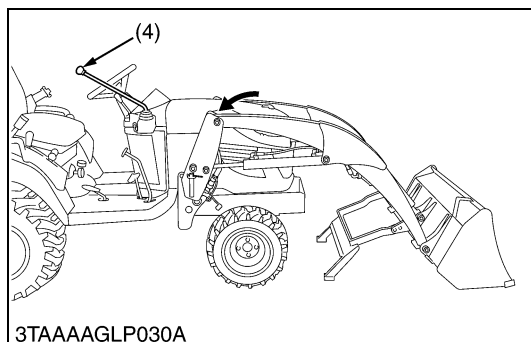
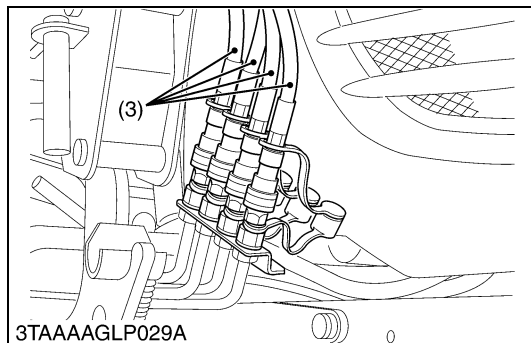
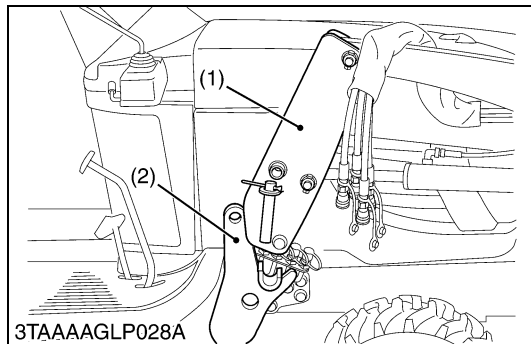

Side Frame and Hoses

1. Slowly drive the tractor between the loader side frames until the rear portion of both side frames touches the main frames as shown.
2. Stop the engine.
3. Connect four hoses with couplers to the nipple on the control valve as indicated with color marks. Then connect the protective caps and plugs to each other.
4. Start the engine and run at idle.
5. Slowly move the loader control lever to dump position to lower the side frames into the main frames and engage the bosses of the main frames to the guide bosses of the side frames. Then lift the front wheels slightly with the loader.

■ IMPORTANT

- **Do not attempt to lift the front wheels with the stand.**
6. Stop the engine. Reinstall the mounting pins and secure them with the locking rods.
 7. Start the engine.
 8. Raise the boom until the stand can be rotated.
 9. Stop the engine.
 10. Store the stand to their original positions and secure it with the spring pin as shown.
 11. Start the engine.
 12. Lower the boom and level the bucket.

- | | |
|----------------|--------------------------|
| (1) Side Frame | (4) Loader Control Lever |
| (2) Main Frame | (5) Spring Pin |
| (3) Hose | (6) Stand |

W1020231

MECHANISM

CONTENTS

1. HYDRAULIC CIRCUIT SCHEMATIC.....	8-M1
2. CONTROL VALVE ASSEMBLY.....	8-M2
[1] STRUCTURE.....	8-M2
[2] OPERATION.....	8-M3
3. BOOM CYLINDER AND BUCKET CYLINDER.....	8-M10

1. HYDRAULIC CIRCUIT SCHEMATIC

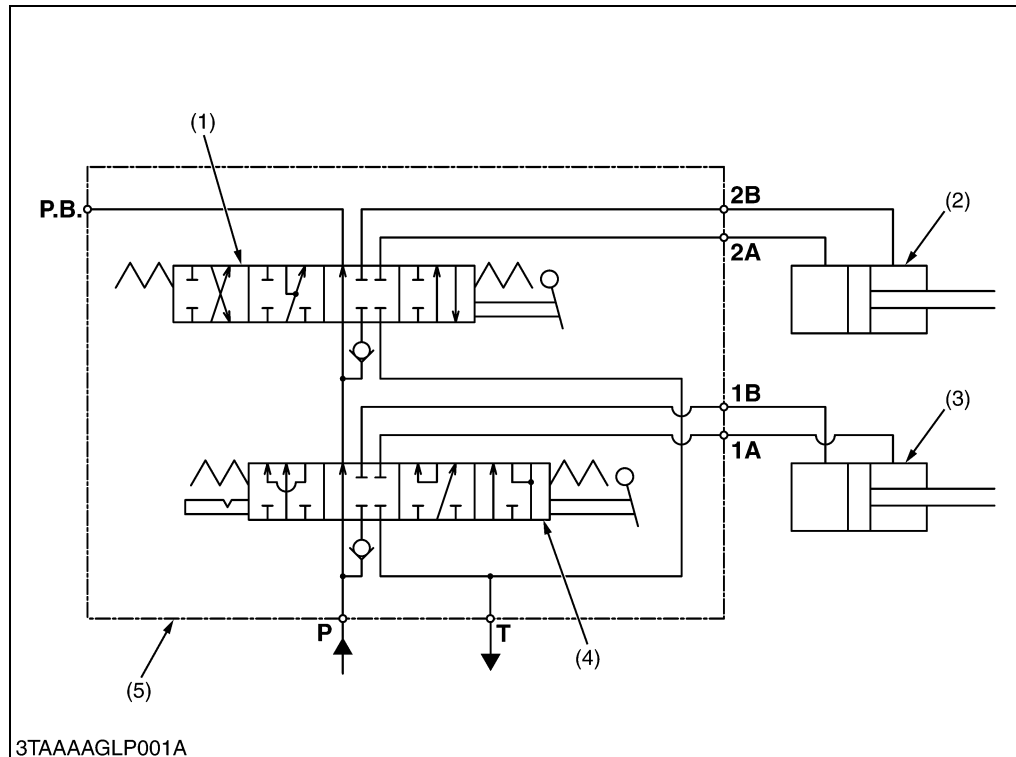

- (1) Bucket Control Valve
- (2) Bucket Cylinder
- (3) Boom Cylinder
- (4) Boom Control Valve
- (5) Control Valve Assembly

P : From Pump
P.B. :To 3-Point Hydraulic System
T : To Tank
1A :1A Port
2A :2A Port
1B :1B Port
2B :2B Port

W1016476

To operate the front loader, the hydraulic oil pressurized by the hydraulic pump flows from **P** port through the boom control valve (4) and the bucket control valve (1) to **P.B.** port or **T** port.

Since relief valve is not equipped in the front loader control valve, the main relief valve in the tractor operates.

2. CONTROL VALVE ASSEMBLY

[1] STRUCTURE

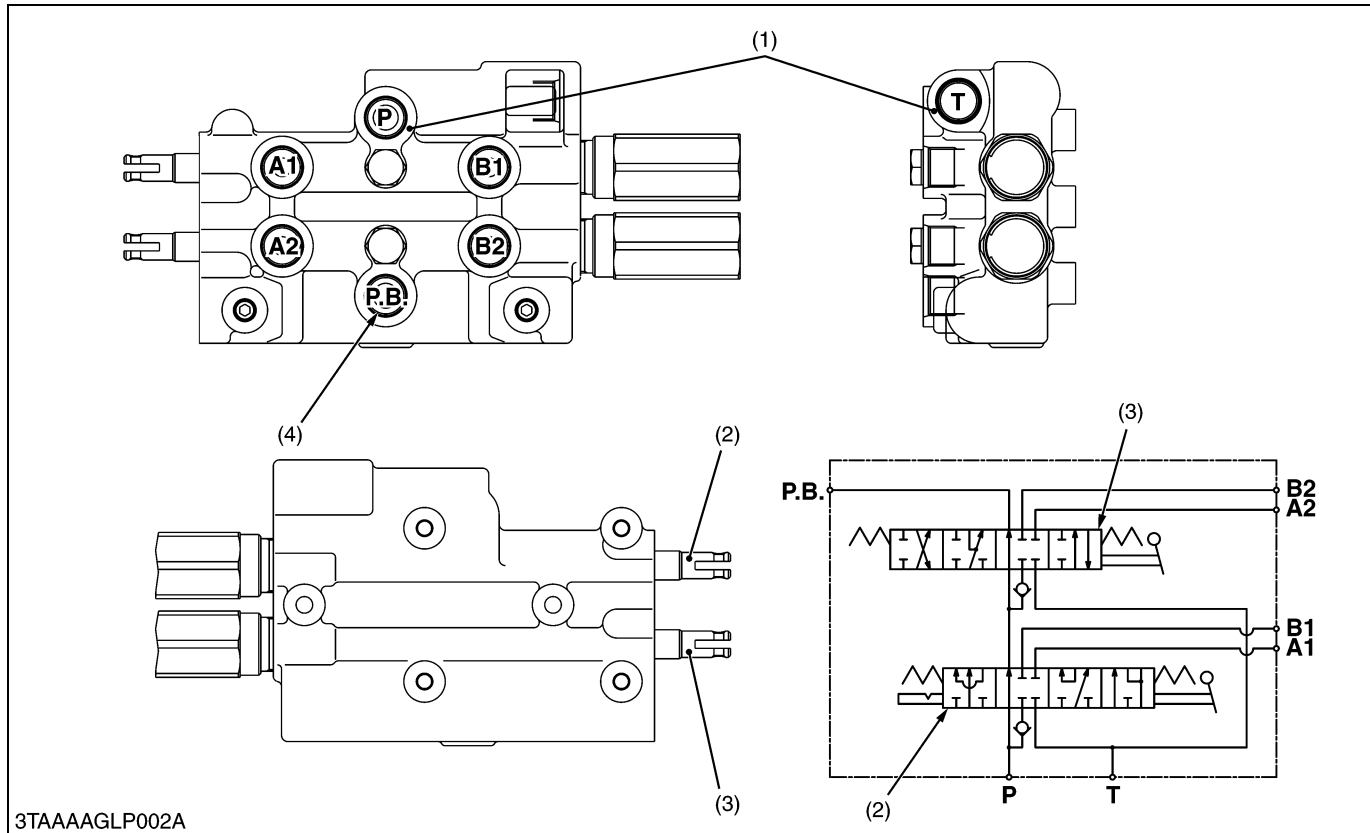

- (1) Inlet and Outlet Section
- (2) Boom Control Valve
- (3) Bucket Control Valve
- (4) Power Beyond

P : P Port (From Pump)
T : T Port (To Tank)

A1 : A1 Port
A2 : A2 Port

B1 : B1 Port
B2 : B2 Port
P.B. : P.B. Port

The control valve assembly is composed of one casting block and four major section as shown above.

(1) Inlet and Outlet Section

This section has **P** and **T** ports.

The **P** port is connected to the **OUTLET** port of hydraulic block by the hydraulic hose.

The **T** port is connected to the **TANK** port of hydraulic block by the hydraulic hose.

(2) Boom Control Section

The boom control valve is of 4-position, 6-connection, detent, spring center type, consisting of a mono block valve housing, spool, load check valve, etc. This valve has **A1** and **B1** ports and controls oil flow to the boom cylinder.

(3) Bucket Control Section

The bucket control valve is of 4-position, 6-connection, no detent, spring center type, consisting of a mono block valve housing, spool, load check valve, etc. This valve has **A2** and **B2** ports and controls oil flow to the bucket cylinder.

(4) Power Beyond

This section has **P.B.** port which is connected to the **INLET** port of hydraulic block by the hydraulic hose, and feeds oil to the three point hydraulic control valve.

[2] OPERATION

■ Neutral

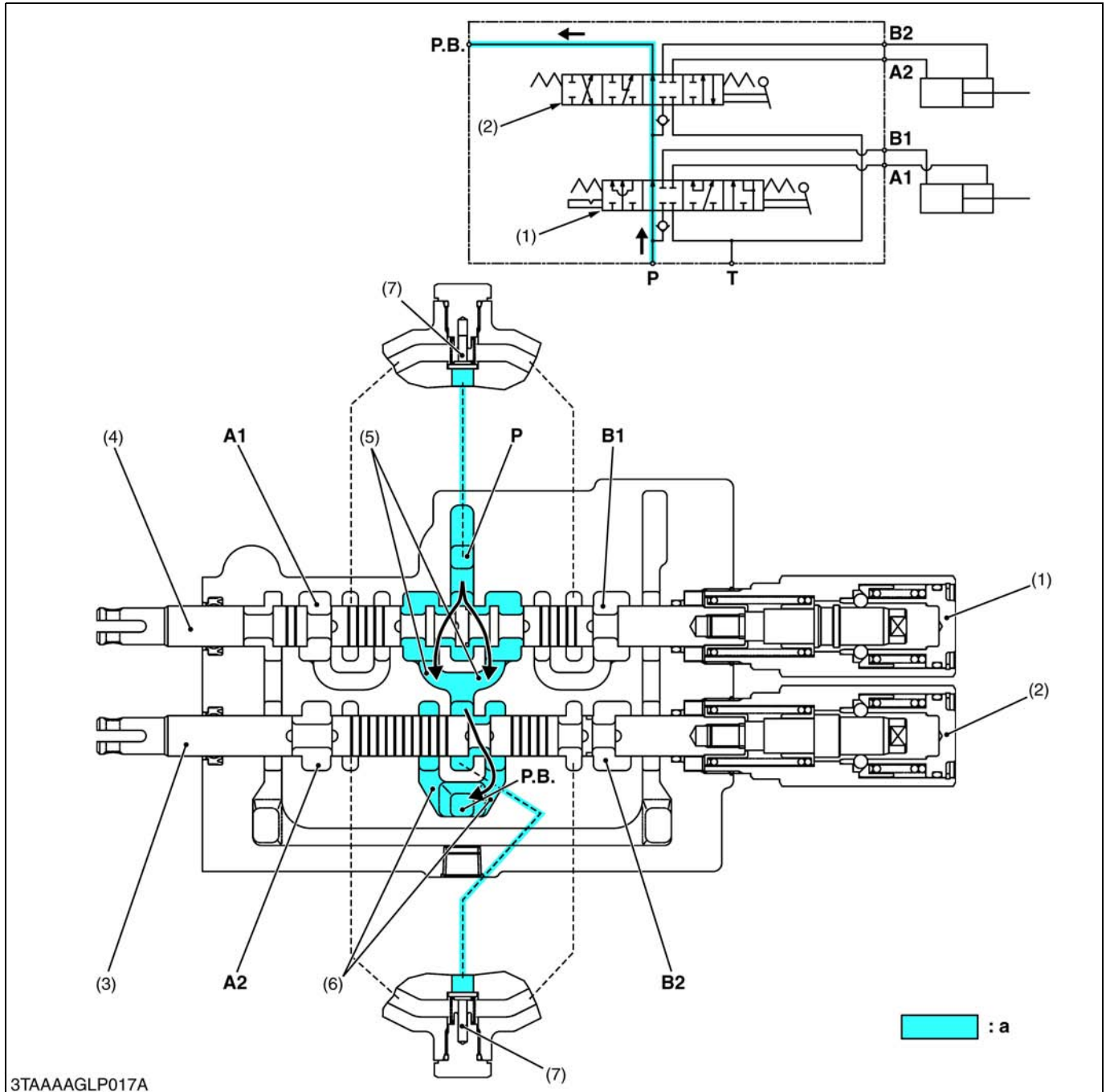

3TAAAAGLP017A

- (1) Boom Control Section
- (2) Bucket Control Section
- (3) Spool
- (4) Spool

- (5) P.B. Passage 1
- (6) P.B. Passage 2
- (7) Load Check Valve

- T : T Port (To Tank)
- P : P Port (From Pump)
- A1 : A1 Port
- A2 : A2 Port

- B1 : B1 Port
- B2 : B2 Port
- P.B. : P.B. Port
- a : Low Pressure

■ Up

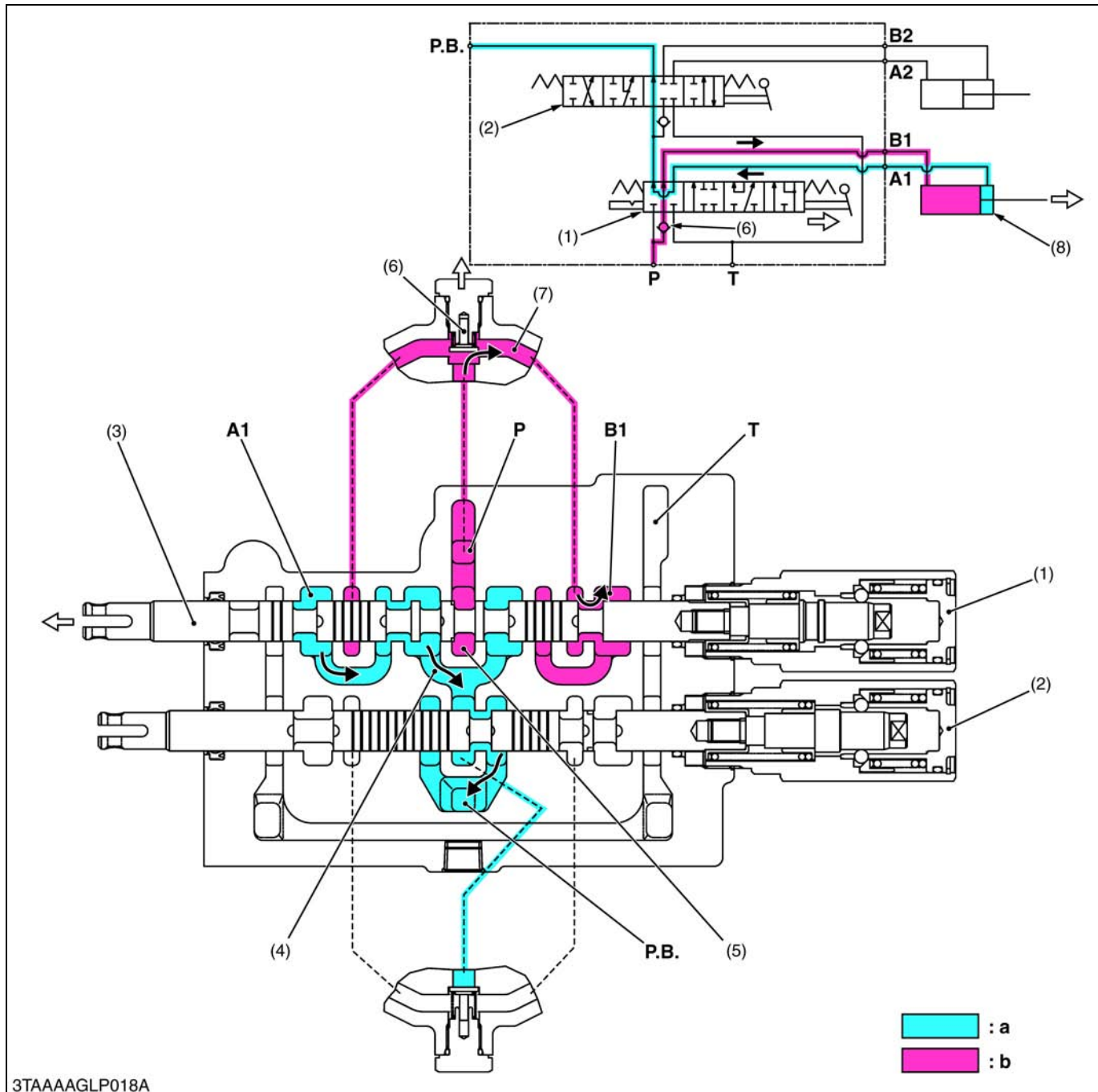

- (1) Boom Control Section
- (2) Bucket Control Section
- (3) Spool
- (4) P.B. Passage 1

- (5) Neutral Passage 1
- (6) Load Check Valve
- (7) Passage 1
- (8) Boom Cylinder

- P : P Port (From Pump)
- T : T Port (To Tank)
- A1 : A1 Port (From Boom Cylinder)

- B1 : B1 Port (To Boom Cylinder)
- P.B. : P.B. Port (To 3 Hitch)
- a : Low Pressure
- b : High Pressure

1. When the hydraulic control lever is set to the "UP" position, the spool (3) of the boom control section (1) moves to the left, which forms oil passages between passage 1 (7) and B1 port, and between A1 port and P.B. passage 1 (4).
2. As the oil passage from the neutral passage 1 (5) to the P.B. passage 1 (4) is closed by the spool (3), the pressurized oil from the P port opens the load check valve (6) and flows through the notched section of the spool (3) and B1 port to extend the boom cylinder (8).
3. Return oil from the boom cylinder (8) flows from the A1 port through the passage in the spool (3) and P.B. passage 1 (4) to the bucket control section (3).

■ Down

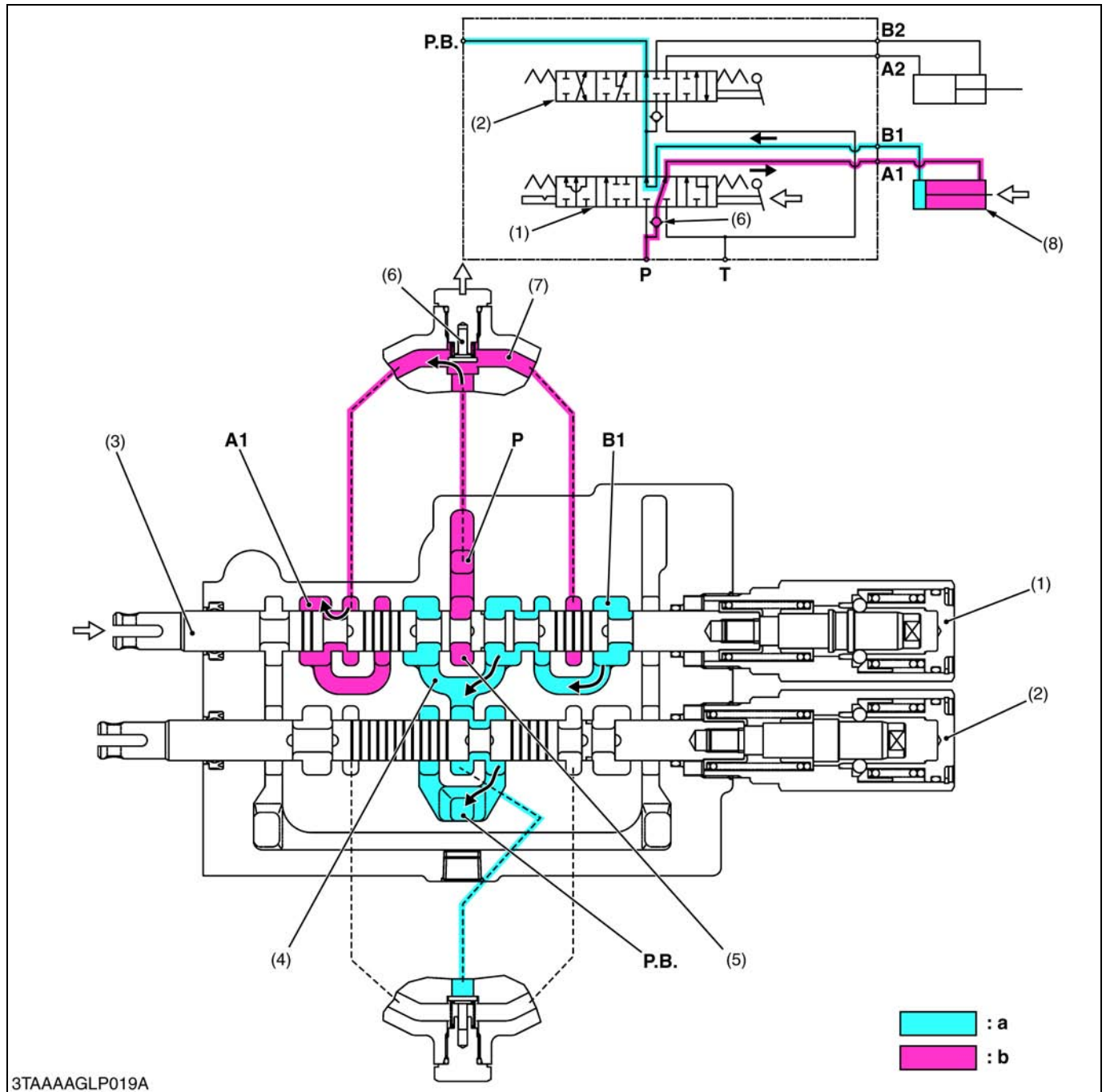

3TAAAAGLP019A

- | | | | |
|----------------------------|-----------------------|--|--|
| (1) Boom Control Section | (5) Neutral Passage 1 | P : P Port (From Pump) | B1 : B1 Port (From Boom Cylinder) |
| (2) Bucket Control Section | (6) Load Check Valve | T : T Port (To Tank) | P.B. : P.B. Port (To 3 Hitch) |
| (3) Spool | (7) Passage 1 | A1 : A1 Port (To Boom Cylinder) | a : Low Pressure |
| (4) P.B. Passage 1 | (8) Boom Cylinder | | b : High Pressure |

1. When the hydraulic control lever is set to the “**DOWN**” position, the spool (3) moves to the right, which forms oil passages between passage 1 (7) and **A1** port, and between **B1** port and **P.B.** passage 1 (4).
2. As the oil passage from the neutral passage 1 (5) to the **P.B.** passage 1 (4) is closed by the spool (3), the pressurized oil from the **P** port opens the load check valve (6) and flows through the notched section of the spool (3) and **A1** port to retract the boom cylinder (8).
3. Return oil from the boom cylinder (8) flows from the **B1** port through the passage in the spool (3) and **P.B.** passage 1 (4) to the bucket control section (2).

■ Floating

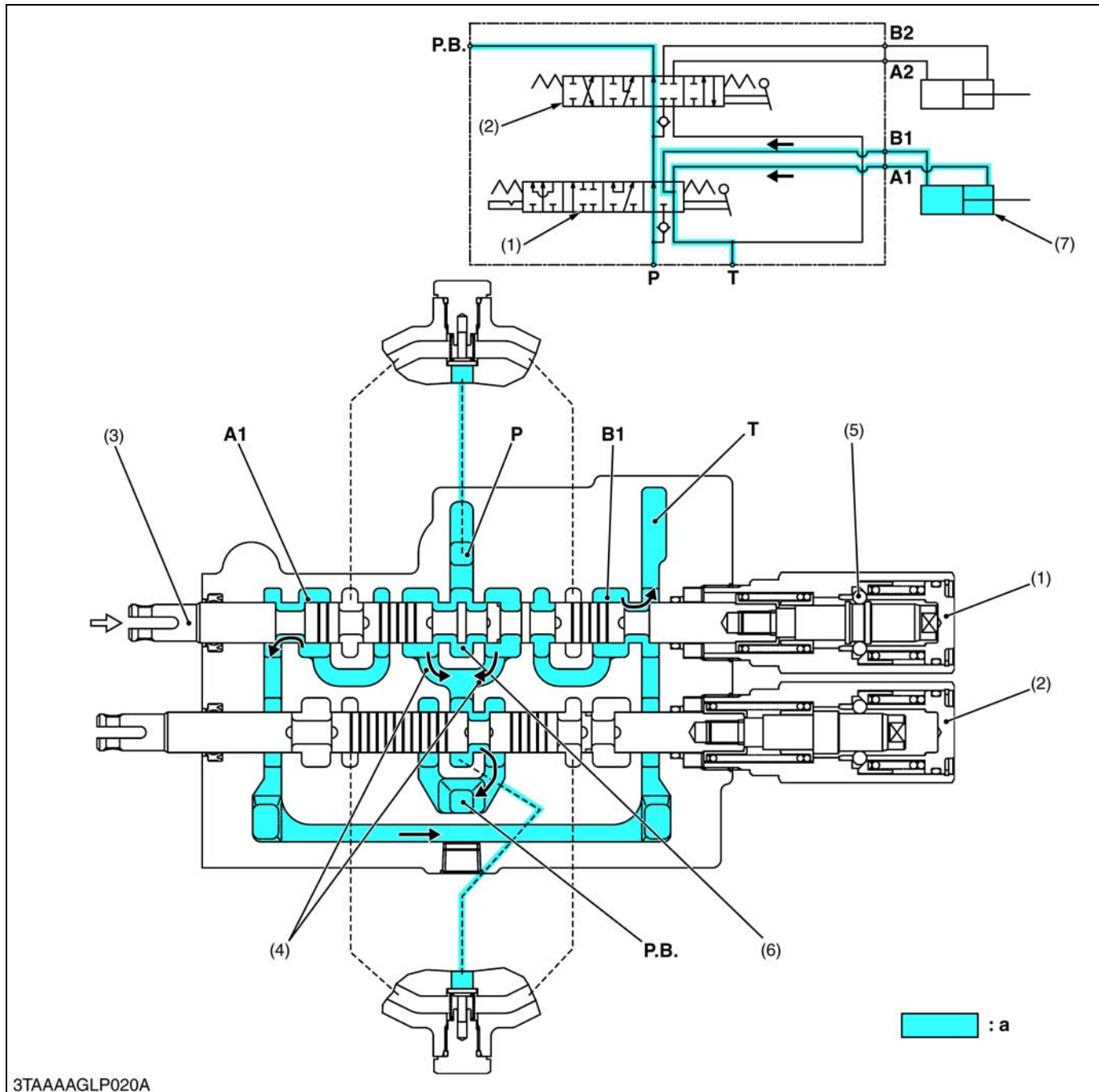

3TAAAAGLP020A

- | | | | |
|----------------------------|-----------------------|-------------------------------|--------------------------------------|
| (1) Boom Control Section | (5) Detent Mechanism | P : P Port (From Pump) | A1 : A1 Port |
| (2) Bucket Control Section | (6) Neutral Passage 1 | T : T Port (To tank) | B1 : B1 Port |
| (3) Spool | (7) Boom Cylinder | | P.B. : P.B. Port (To 3 Hitch) |
| (4) P.B. Passage 1 | | | a : Low Pressure |

1. When the hydraulic control lever is set to the "FLOAT" position, the spool (3) moves further to the right from the "DOWN" position and is retained by the detent mechanism (5).
2. This forms oil passages among the A1 port, B1 port and T port. As a result, oil in the boom cylinder (7) flows freely from the A1 port and B1 port through the T port to the transmission case.
3. Oil entering the P port flows to the bucket control section (2) through the neutral passage 1 (6) and P.B. passage 1 (4).

■ Roll-back

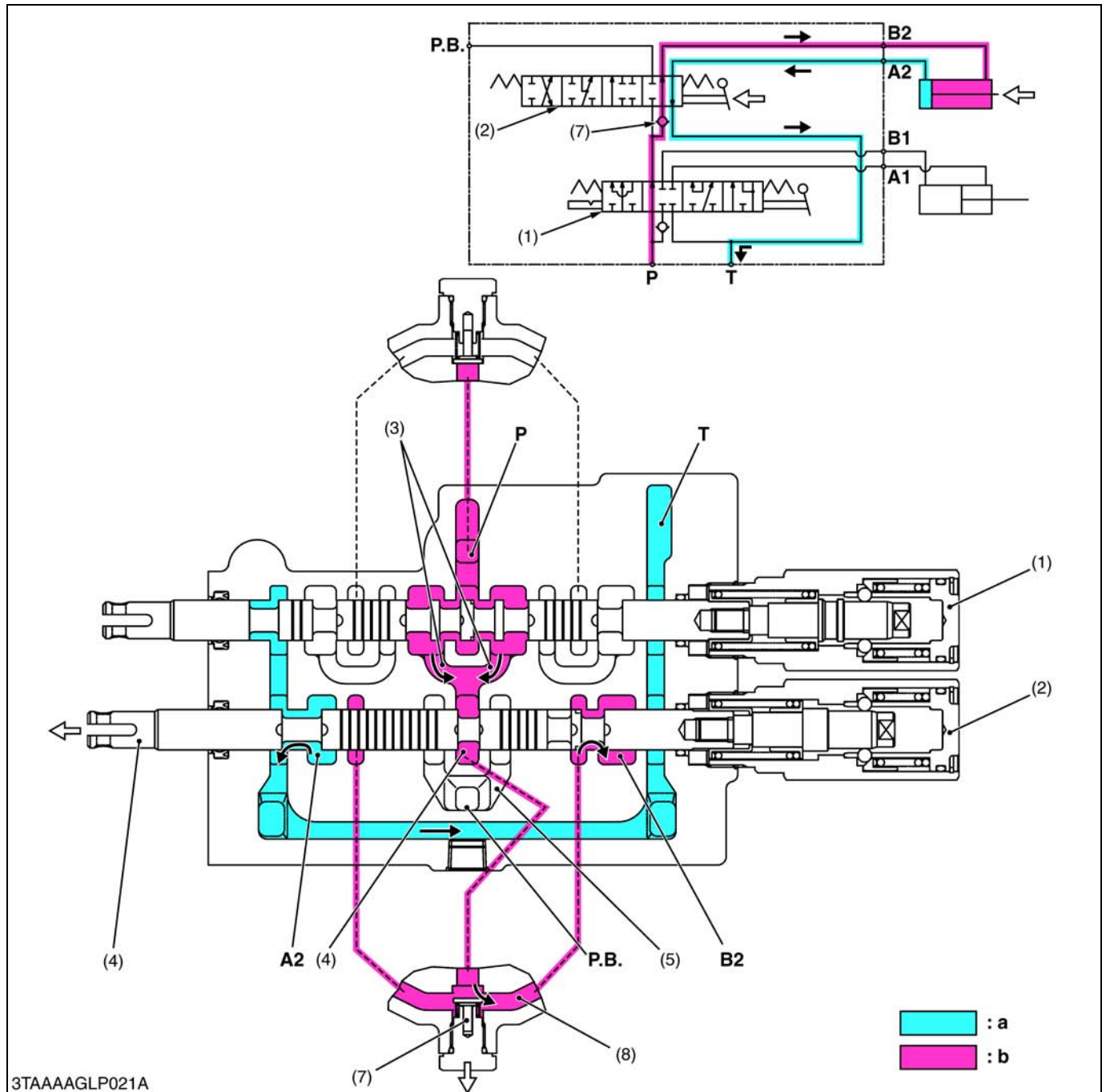

3TAAAAGLP021A

- | | | | |
|----------------------------|----------------------|-------------------------------------|--------------------------|
| (1) Boom Control Section | (6) P.B. Passage 2 | P : P Port (From Pump) | B2 : B2 Port |
| (2) Bucket Control Section | (7) Load Check Valve | T : T Port (To Tank) | (To Bucket Cylinder) |
| (3) P.B. Passage 1 | (8) Passage 2 | P.B. :P.B. Port (To 3 Hitch) | a : Low Pressure |
| (4) Spool | (9) Bucket Cylinder | A2 : A2 Port | b : High Pressure |
| (5) Neutral Passage 2 | | (From Bucket Cylinder) | |

- When the hydraulic control lever is set to the “**ROLL-BACK**” position, the spool (4) of the bucket control section (2) moves to the left, which forms oil passages between passage 2 (8) and **B2** port, and between **A2** port and **T** port.
- The pressure-fed oil from the **P** port flows to the neutral passage 2 (5) through the boom control section (1) and **P.B.** passage 1 (3). As the oil passage from the neutral passage 2 (5) to the **P.B.** passage 2 (6) is closed by the spool (4), this oil opens the load check valve (7), and flows through the notched section of the spool (4) and **B2** port to retract the bucket cylinder (9).
- Return oil from the bucket cylinder (9) flows to the transmission case through the **A2** port and **T** port.

■ Dump 1

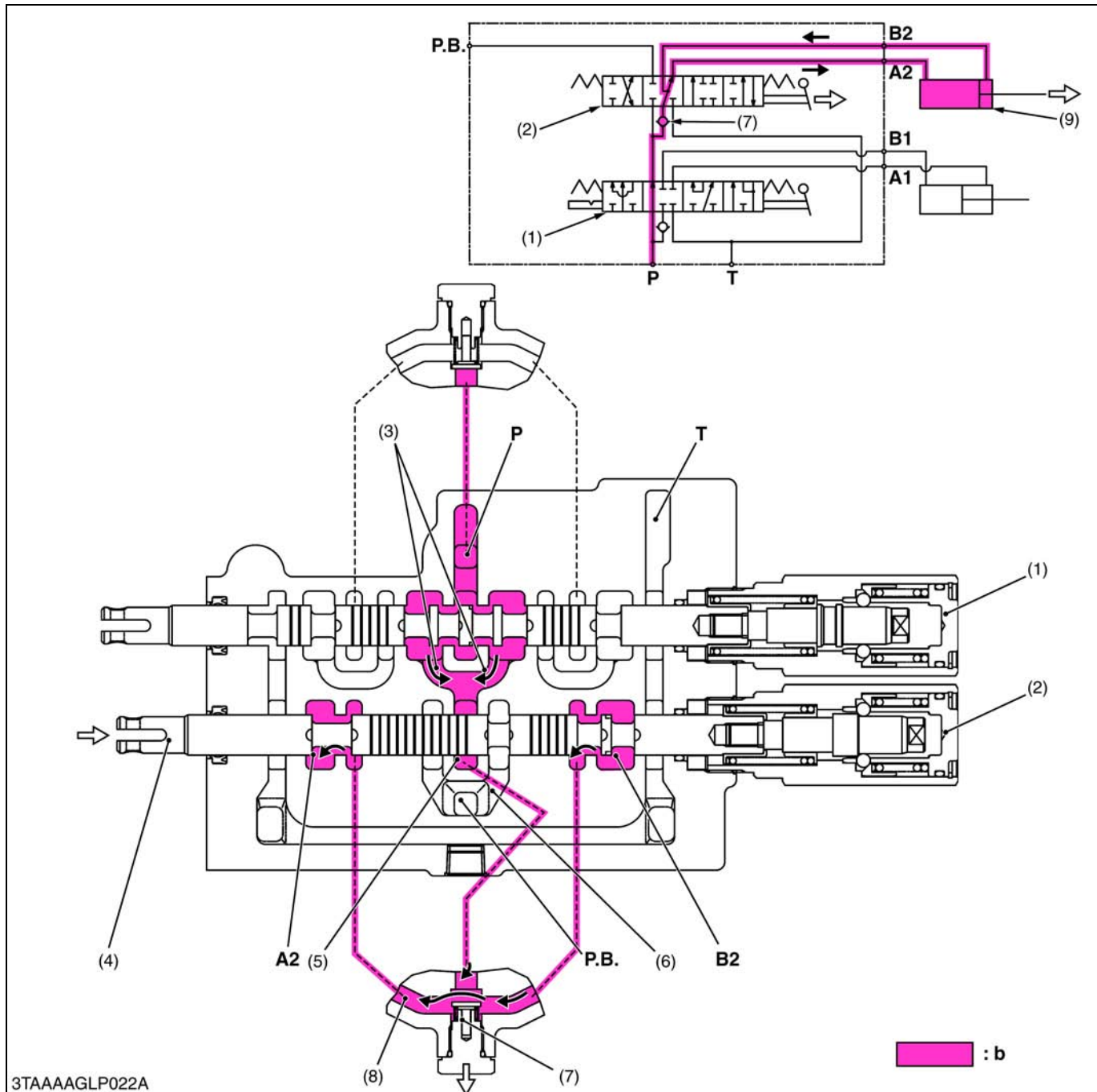

3TAAAAGLP022A

- | | | | |
|----------------------------|----------------------|-------------------------------------|--|
| (1) Boom Control Section | (6) P.B. Passage 2 | P : P Port (From Pump) | A2 : A2 Port (To Bucket Cylinder) |
| (2) Bucket Control Section | (7) Load Check Valve | T : T Port (To Tank) | B2 : B2 Port (From Bucket Cylinder) |
| (3) P.B. Passage 1 | (8) Passage 2 | P.B. :P.B. Port (To 3 Hitch) | b : High Pressure |
| (4) Spool | (9) Bucket Cylinder | | |
| (5) Neutral Passage 2 | | | |

- When the hydraulic control lever is set to the “DUMP 1” position, the spool (4), which forms oil passages among passage 2 (8), **A2** port and **B2** port.
- The pressure-fed oil from the **P** port flows through the boom control valve, opens the load check valve, and flows to the bucket cylinder to extend the cylinder through the notched section of the spool and **A2** port.
- Return oil from the bucket cylinder (9) flows from the **B2** port to the passage 2 (8), and flows to the **A2** port together with the pressure-fed oil from the **P** port. As a result, the dump speed is increased.

(Reference)

- The oil pressure of the **A2** port and **B2** port is identical, but the bucket cylinder extends by the difference of received pressure area (cylinder rod part).

■ Dump 2

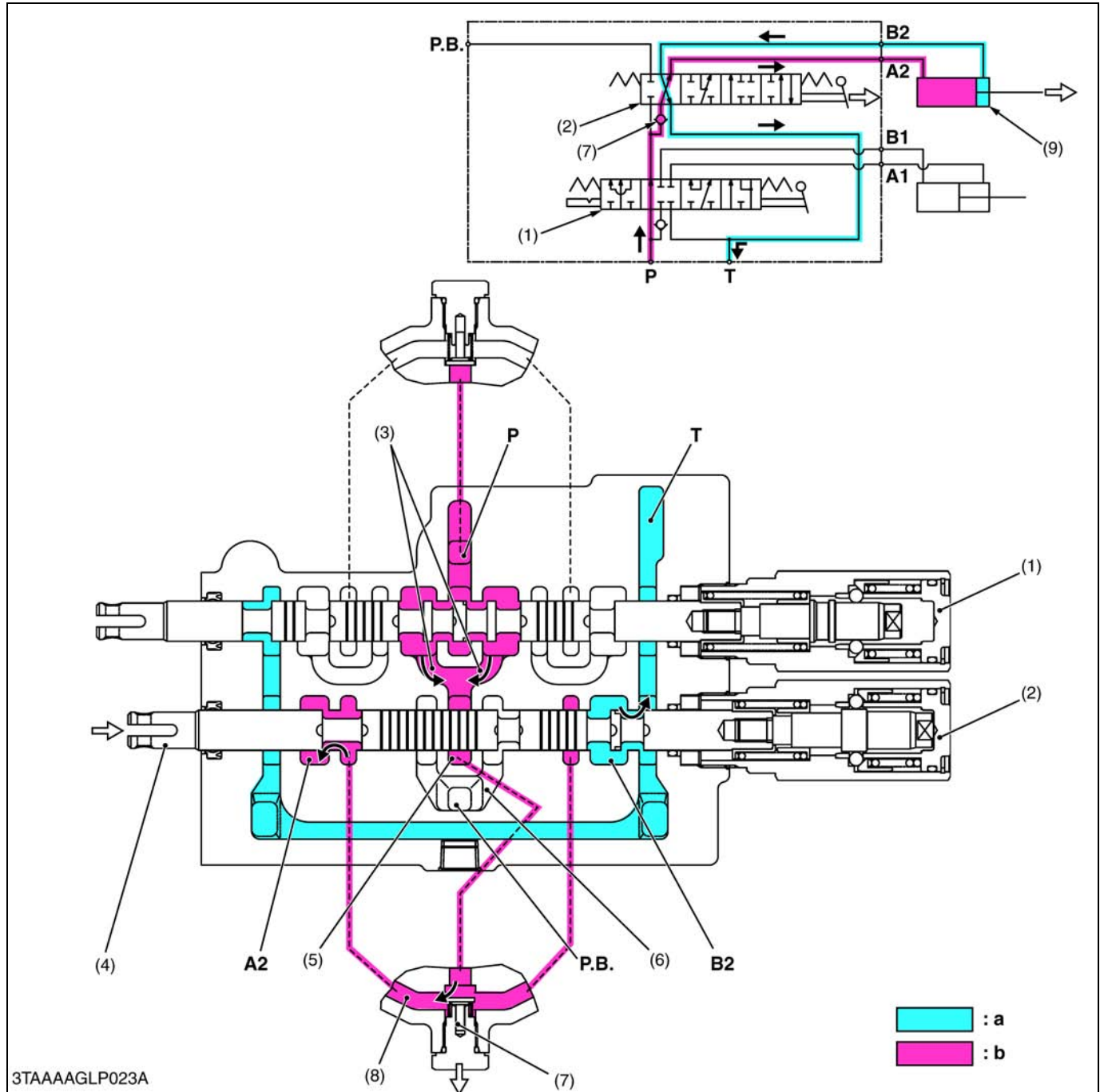

3TAAAAGLP023A

- (1) Boom Control Section
- (2) Bucket Control Section
- (3) P.B. Passage 1
- (4) Spool
- (5) Neutral Passage 2

- (6) P.B. Passage 2
- (7) Load Check Valve
- (8) Passage 2
- (9) Bucket Cylinder

P : P Port (From Pump)
T : T Port (To Tank)
P.B. :P.B. Port (To 3 Hitch)

A2 : A2 Port
 (To Bucket Cylinder)
B2 : B2 Port
 (From Bucket Cylinder)
a : Low Pressure
b : High Pressure

1. When the hydraulic control lever is set to the “DUMP 2” position, the spool (4) of the bucket control section (2) moves to the right of the bucket control section (2) moves further to the right from the “DUMP 1” position, which forms oil passages between passage 2 (8) and A2 port, and between B2 port and T port.
2. The pressure-fed oil from the P port flows to the neutral passage 2 (5) through the boom control section (1) and P.B. passage 1 (3). As the oil passage from the neutral passage 2 (5) to the P.B. passage 2 (6) is closed by the spool (4), this oil opens the load check valve (7) and flows through the notched section of the spool (4) and B2 port to extend the bucket cylinder (9).
3. Return oil from the bucket cylinder (9) flows to the transmission case through the B2 port and T port.

3. BOOM CYLINDER AND BUCKET CYLINDER

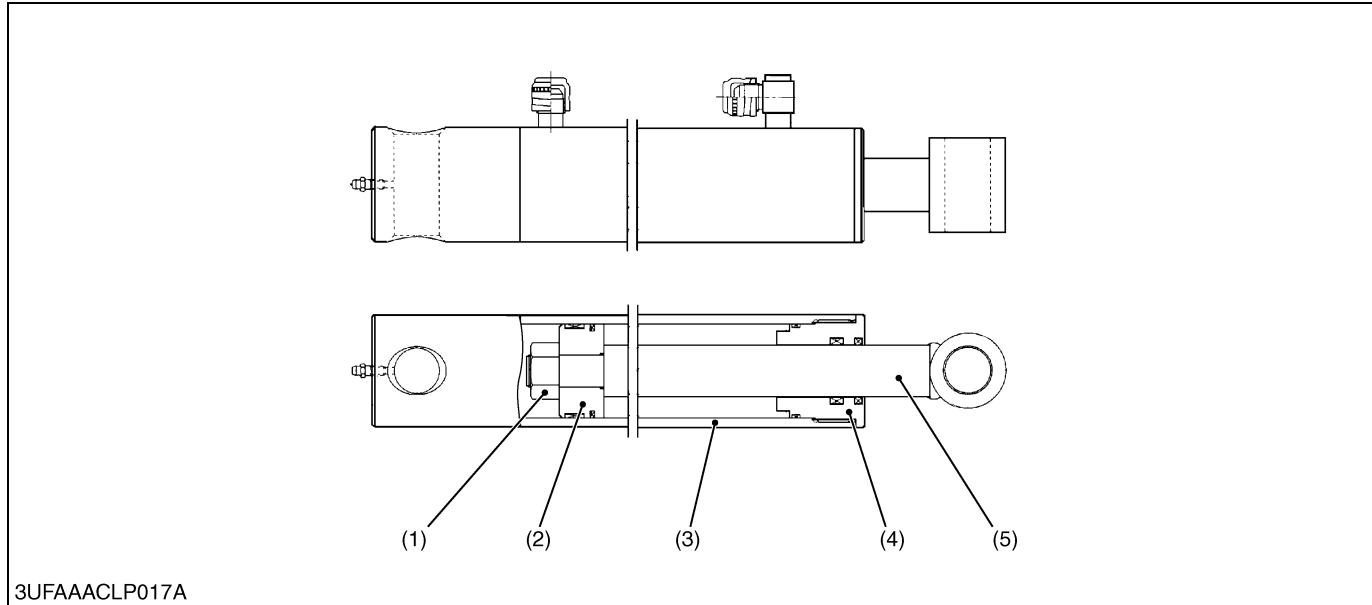

- (1) Nut
- (2) Piston
- (3) Cylinder Tube
- (4) Head
- (5) Piston Rod

Both boom cylinder and bucket cylinder consists of a head (4), cylinder tube (3), piston rod (5), piston (2), and other parts as shown in the figure above. They are single-rod double acting cylinder in which the reciprocating motion of the piston is controlled by hydraulic force applied to both of its ends.

Cylinder Specifications

		LA203	LA243
Boom Cylinder	Cylinder I.D.	40 mm (1.57 in.)	
	Rod O.D.	25 mm (0.98 in.)	
	Stroke	281 mm (11.1 in.)	326 mm (12.8 in.)
Bucket Cylinder	Cylinder I.D.	65 mm (2.56 in.)	
	Rod O.D.	30 mm (1.18 in.)	
	Stroke	204 mm (8.03 in.)	

W1025274

SERVICING

CONTENTS

1. TROUBLESHOOTING	8-S1
2. SERVICING SPECIFICATIONS	8-S2
3. TIGHTENING TORQUES	8-S3
4. CHECKING, DISASSEMBLING AND SERVICING.....	8-S4
[1] CHECKING AND ADJUSTING	8-S1
(1) Control Valve	8-S4
[2] DISASSEMBLING AND ASSEMBLING.....	8-S1
(1) Control Valve	8-S1
(2) Bucket, Boom and Hydraulic Cylinders.....	8-S1
(3) Side Frames, Front Guard and Main Frames	8-S1
[3] SERVICING	8-S10

1. TROUBLESHOOTING

Symptom	Probable Cause	Solution	Reference Page
Boom Does Not Rise	Control valve malfunctioning	Repair or replace	8-S5
	Boom cylinder defective	Repair or replace	8-S7
	Control lever linkage defective	Repair or replace	8-S5
	Hydraulic pump malfunctioning	Repair or replace	5-S13
	Oil filter clogged	Clean or replace	G-14
	Hydraulic hose damaged	Replace	–
Boom Does Not Lower	Control valve malfunctioning	Repair or replace	8-S5
Insufficient Boom Speed	Boom cylinder tube worn or damaged	Replace	8-S7
	Boom cylinder piston ring (piston seal and O-ring) worn or damaged	Replace	8-S8
	Oil leaks from tube joints	Repair	8-S7
	Relief valve setting pressure too low	Adjust	5-S4
	Insufficient transmission fluid	Refill	8-G3
	Dirty relief valve	Clean	5-S4
Bucket Does Not Move	Control valve malfunctioning	Repair or replace	8-S5
	Bucket cylinder defective	Repair or replace	8-S7
	Control lever linkage defective	Repair or replace	8-S5
	Hydraulic pump malfunctioning	Repair or replace	5-S13
	Oil filter clogged	Clean or replace	G-14
	Relief valve spring damaged	Replace	5-S4
	Hydraulic hose damaged	Replace	–
	Dirty relief valve	Clean	5-S4
Insufficient Bucket Speed	Bucket cylinder tube worn or damaged	Replace	8-S7
	Bucket cylinder piston ring (piston seal and O-ring) worn or damaged	Replace	8-S8
	Oil leaks from tube joints	Repair	–
	Insufficient transmission fluid	Refill	8-G3
Front End Loader Drops by its Weight	Boom cylinder tube worn or damaged	Replace	8-S7
	Boom cylinder piston ring (piston seal and O-ring) worn or damaged	Replace	8-S8
	Oil leaks from tube joints	Repair	–
	Control valve malfunctioning	Repair or replace	8-S5

W1014322

2. SERVICING SPECIFICATIONS

Item		Factory Specification	Allowable Limit
Piston Rod	Bend	–	0.25 mm 0.0098 in.

W1013874

3. TIGHTENING TORQUES

Tightening torques of screws, bolts and nuts on the table below are especially specified.
(For general use screws, bolts and nuts : See page 8-G4.)

Item	N·m	kgf·m	lbf·ft
Boom cylinder piston mounting nut	150 to 180	15.3 to 18.3	111 to 132
Bucket cylinder piston mounting nut	350 to 400	35.7 to 40.7	259 to 295
Main frame mounting bolt (M14)	147	15.0	108

W1012736

4. CHECKING, DISASSEMBLING AND SERVICING

[1] CHECKING AND ADJUSTING

(1) Control Valve

Relief Valve Setting Pressure

■ NOTE

- The relief valve is not installed on this model. However the relief valve of the tractor hydraulic system is used as the relief valve of the front loader. Refer to hydraulic section.

(Reference)

Relief valve setting pressure	Factory spec.	12.3 to 12.7 MPa 125 to 130 kgf/cm ² 1780 to 1840 psi
-------------------------------	---------------	--

Condition

- Engine speed..... Maximum
- Oil temperature..... 45 to 55 °C
113 to 131 °F

W1014688

[2] DISASSEMBLING AND ASSEMBLING

(1) Control Valve



Step and Battery

⚠ CAUTION

- When disconnecting the battery cables, disconnect the negative cable from the battery first. When connecting, connect the positive cable to the battery first.

1. Remove the under panel (1).
2. Disconnect the negative cable (3) from the battery (2).
3. Remove the valve covers (4).
4. Remove the HST pedal (5) and the step (6).

- | | |
|--------------------|-----------------|
| (1) Under Panel | (4) Valve Cover |
| (2) Battery | (5) HST Pedal |
| (3) Negative Cable | (6) Step |

W1012394

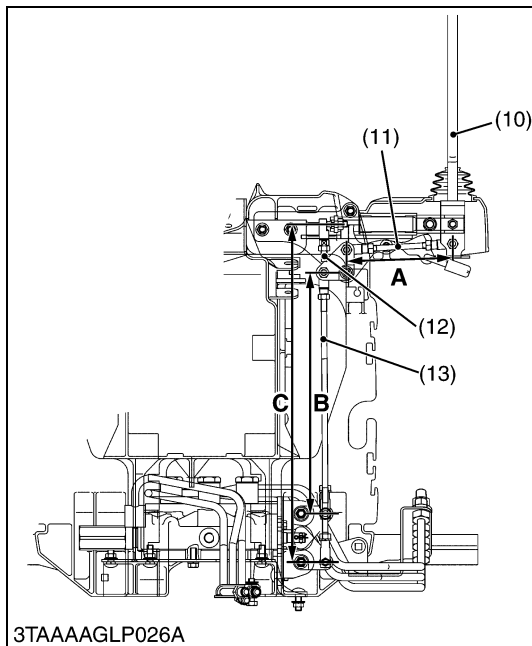
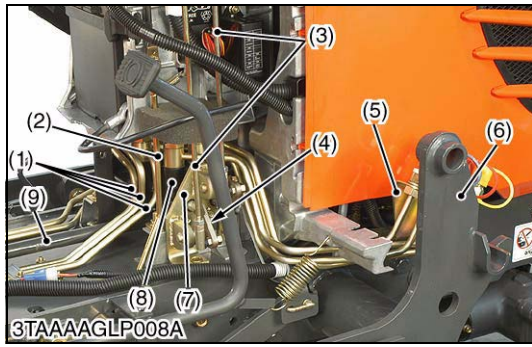

Control Valve

1. Remove the loader frame (6).
2. Disconnect the cruise control rod (2).
3. Disconnect the frame loader control rods (3).
4. Remove the brake spring.
5. Remove the arms (4) from spool end.
6. Remove the stay bolt (5).
7. Remove the valve stay (7).
8. Disconnect the pipes (1).
9. Remove the control valve (8) with pipes.

(When reassembling)

- After reassembling a valve, check for oil leakage by starting up engine.

■ IMPORTANT

- **When starting up engine, watch out for the rotating propeller shaft (9).**

(Reference)

- When adjusting the length of rods, make the lever come to the neutral position.

A : 145 mm (5.71 in.)

B : 315 mm (12.4 in.)

C : 448 mm (17.6 in.)

- | | |
|------------------------------|---------------------------------|
| (1) Pipe | (8) Control Valve |
| (2) Cruise Control Rod | (9) Propeller Shaft |
| (3) Front Loader Control Rod | (10) Front Loader Control Lever |
| (4) Arm | (11) Rod 1 |
| (5) Stay | (12) Rod 2 |
| (6) Loader Frame | (13) Rod 3 |
| (7) Valve Stay | |

W1013200

Disassembling Control Valve

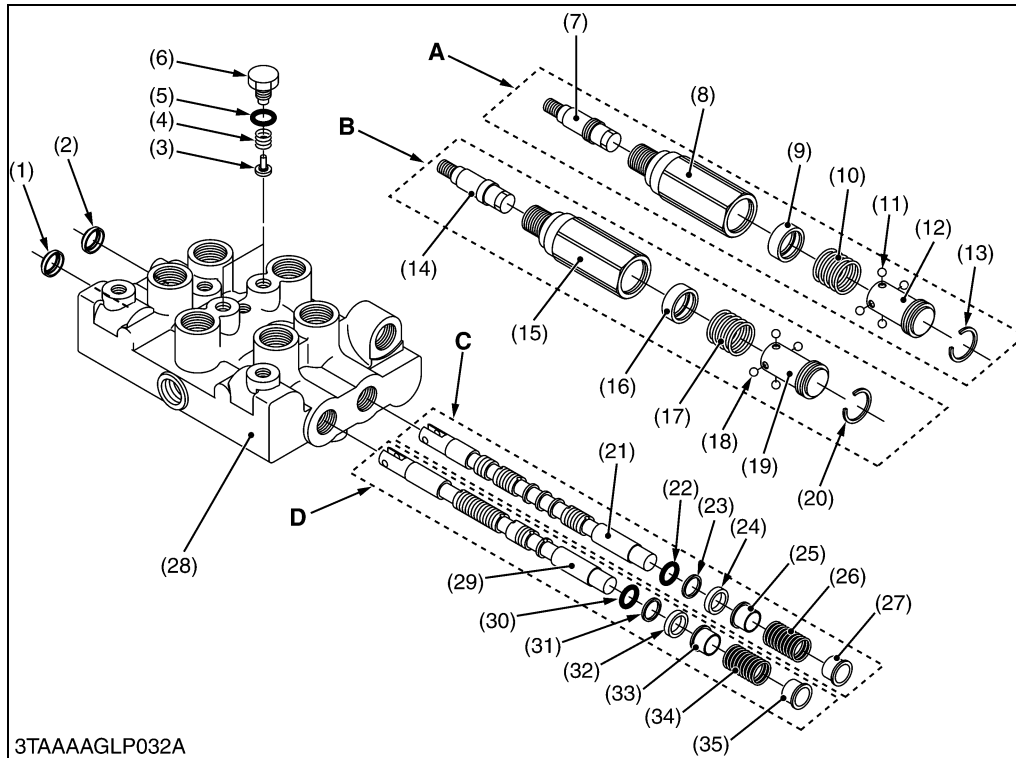

- (1) Dust Seal
- (2) Dust Seal
- (3) Load Check Valve
- (4) Spring
- (5) O-ring
- (6) Plug
- (7) Bolt
- (8) Plug
- (9) Seat
- (10) Spring
- (11) Ball
- (12) Stopper
- (13) Ring
- (14) Bolt
- (15) Plug
- (16) Seat
- (17) Spring
- (18) Ball
- (19) Stopper
- (20) Ring
- (21) Spool
- (22) O-ring
- (23) Back-up Ring
- (24) Collar
- (25) Spring Holder
- (26) Spring
- (27) Spring Holder
- (28) Valve Body
- (29) Spool
- (30) O-ring
- (31) Back-up Ring
- (32) Collar
- (33) Spring Holder
- (34) Spring
- (35) Spring Holder

A, C : Boom Control Section
B, D : Bucket Control Section

W1013558

1. Remove the plugs (6) and take out the spring (4) and load check valve (3).
2. Remove the seal plates (8), (15) with other parts inside plug (C), (D).
3. Draw out the spools (21), (29) with other component parts (A), (B) from the valve body (28).

(When reassembling)

- Clean all parts with a suitable solvent, and dry with a lint-free cloth or air.
- Visually inspect all parts for damage,
- Install the spools to the valve body, not to damage the O-ring.

(2) Bucket, Boom and Hydraulic Cylinders

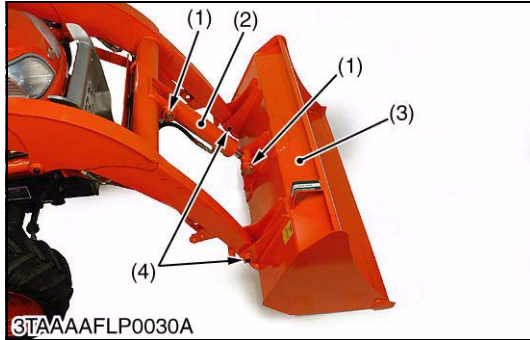

Bucket and Bucket Cylinder

1. Remove the pins (4) the lower pin (1) and remove the bucket (3).
2. Disconnect the hydraulic hoses from the bucket cylinder (2).
3. Remove the upper pin (1) and remove the bucket cylinder (2).

(When reassembling)

- When installing the bucket cylinder (2), the hydraulic port should face inside and be careful of the direction of grease fittings.

- | | |
|---------------------|------------|
| (1) Pin | (3) Bucket |
| (2) Bucket Cylinder | (4) Pin |

W1016780

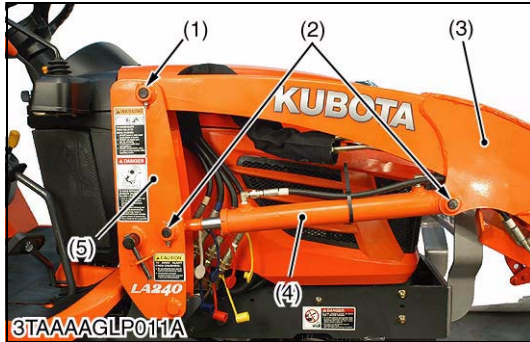

Boom Cylinder and Hydraulic Tubes

1. Disconnect the hydraulic hoses from the boom cylinders (4).
2. Remove the pins (2) and remove the boom cylinders (4).
3. Disconnect the hydraulic hoses (6) with quick couplers at the control valve.
4. Remove the pins (1) and remove the boom (3) from the side frame (5).
5. Remove the hydraulic tubes (7) from the boom (3).

(When reassembling)

- When installing the boom cylinders (4), the hydraulic port should face inside and be careful of the direction of grease fittings.

- | | |
|-------------------|--------------------|
| (1) Pin | (5) Side Frame |
| (2) Pin | (6) Hydraulic Hose |
| (3) Boom | (7) Hydraulic Tube |
| (4) Boom Cylinder | |

W1016879

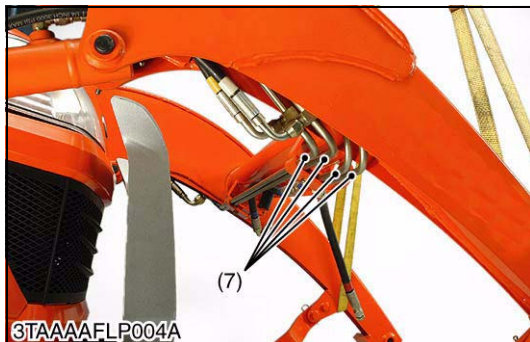
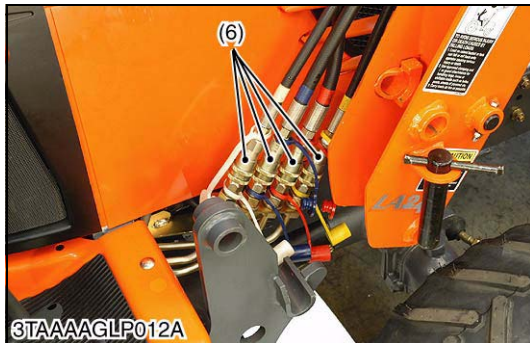

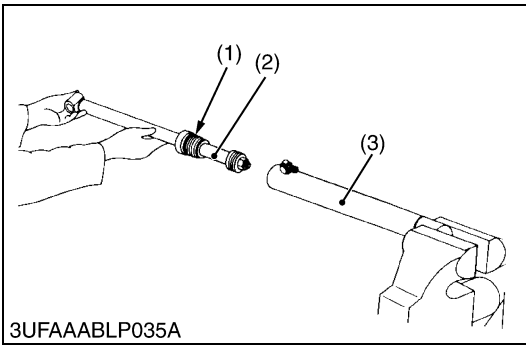

3UFAAABLP035A

Piston Rod Assembly

1. Drain hydraulic oil from the cylinder, and secure the tube end of the cylinder in a vise.
2. Unscrew the cylinder head (1) with the adjustable gland nut wrench (4).
3. Pull out the piston rod assembly (2) from the cylinder tube (3).

(When reassembling)

- Visually inspect the cylinder tube for signs of scoring or damage.
- Insert the piston rod assembly to the cylinder tube, not to damage the piston seal on the piston.
- Install the cylinder head to the cylinder tube, not to damage the O-ring on the cylinder head.

- (1) Cylinder Head (3) Cylinder Tube
 (2) Piston Rod Assembly (4) Adjustable Gland Nut Wrench

W1017050

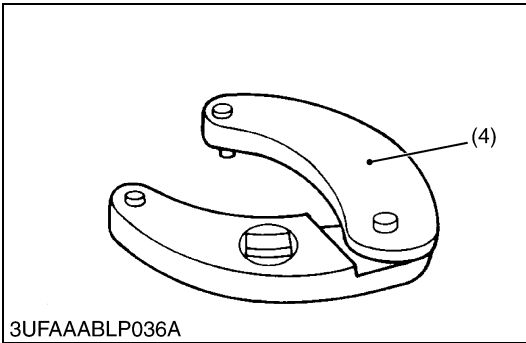

3UFAAABLP036A

Cylinder Head, Piston and Nut

1. Secure the rod end in a vise.
2. Unscrew the nut (4), and remove the piston (3) and cylinder head (2) from the piston rod (1).

(When reassembling)

- Visually inspect all parts for signs of scoring or damage.
- Insert the piston rod to the cylinder head, not to damage the wiper seal (5) and oil seal (6).

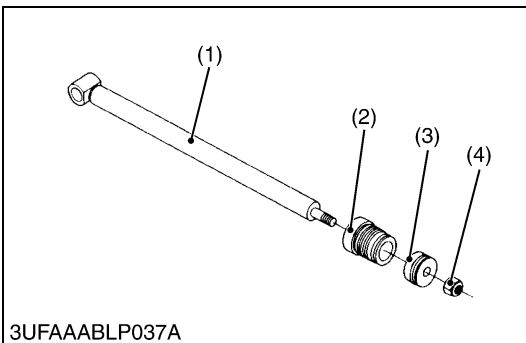

3UFAAABLP037A

Tightening torque	Boom cylinder piston mounting nut	150 to 180 N·m 15.3 to 18.3 kgf·m 111 to 132 ft-lbs
	Bucket cylinder piston mounting nut	350 to 400 N·m 35.7 to 40.7 kgf·m 259 to 295 ft-lbs

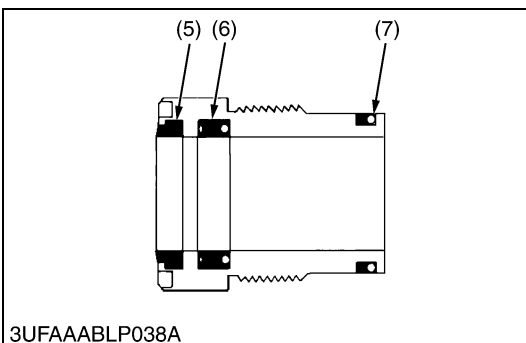

3UFAAABLP038A

- (1) Piston Rod (5) Wiper Seal
 (2) Cylinder Head (6) Oil Seal
 (3) Piston (7) O-ring
 (4) Nut

W1017322

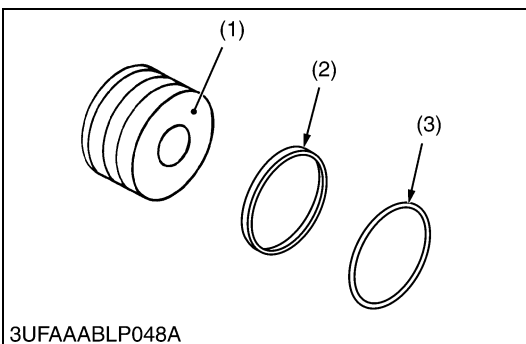

3UFAAABLP048A

Piston Seal and O-ring

1. Remove the piston seal (2) and O-ring (3) from the piston (1).

■ IMPORTANT

- When installing the O-ring (3) and piston seal (2) to the piston (1), use the slide jig and correcting jig as shown in “Special Tools” of “GENERAL” section.

- (1) Piston (a) Slide Jig
 (2) Piston Seal (b) Correcting Jig
 (3) O-ring

W1017590

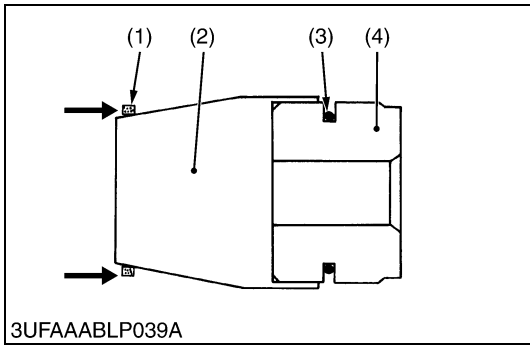

3UFAAABLP039A

Installing O-ring and Piston Seal

1. Place the slide jig (2) on the piston (4).
2. Install the O-ring (3) to the piston using the slide jig.
3. Install the piston seal (1) over the O-ring using the slide jig.
4. Compress the piston seal to the correct size by installing the piston into the correcting jig (5).

NOTE

- Do not turn (roll) the piston seal as you install it.

- | | |
|-----------------|--------------------|
| (1) Piston Seal | (4) Piston |
| (2) Slide Jig | (5) Correcting Jig |
| (3) O-ring | |

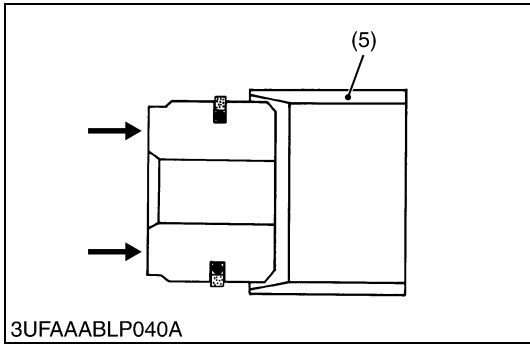

3UFAAABLP040A

W1018621

(3) Side Frames, Front Guard and Main Frames

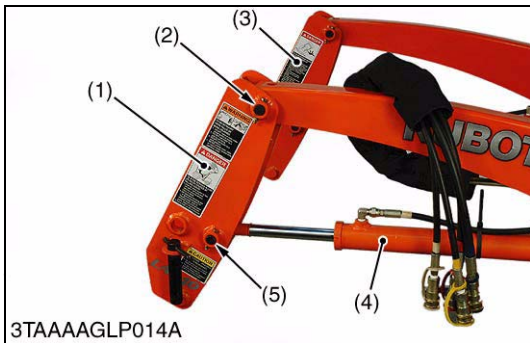

3TAAAAGLP014A

Side Frames

1. Remove the pins (2), (5).
2. Remove the side frames (1) from the boom assembly (3) and the boom cylinder (4).

- | | |
|-------------------|-------------------|
| (1) Side Frame | (4) Boom Cylinder |
| (2) Pin | (5) Pin |
| (3) Boom Assembly | |

W1015835

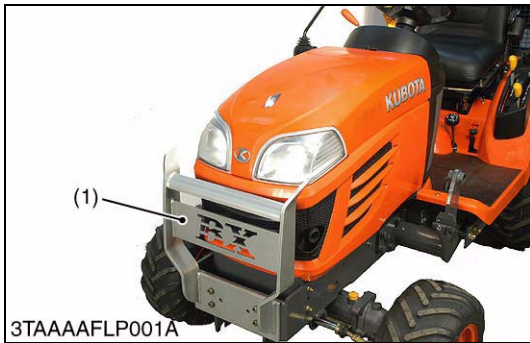

3TAAAFLP001A

Front Guard

1. Remove the front guard (1).

- | |
|-----------------|
| (1) Front Guard |
|-----------------|

W1015954

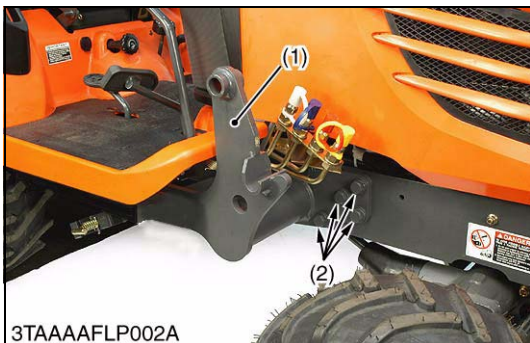

3TAAAFLP002A

Main Frames

1. Remove the main frame mounting bolts and nuts (2) from the tractor body.
2. Remove the main frame (1).

Tightening torque	Main frame mounting bolt (M14)	147 N·m 15.0 kgf·m 108 ft·lbs
-------------------	--------------------------------	-------------------------------------

- | | |
|----------------|------------------------------|
| (1) Main Frame | (2) Main Frame Mounting Bolt |
|----------------|------------------------------|

W1016042

[3] SERVICING

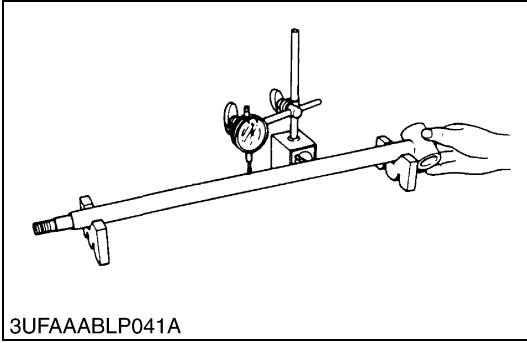

Piston Rod Bend

1. Place piston rod on V blocks.
2. Set a dial indicator on the center of the rod.
3. Turn the piston rod and read the dial indicator.
4. If the measurement exceeds the allowable limit, replace it.

Piston rod bend	Allowable limit	0.25 mm 0.0098 in.
-----------------	-----------------	-----------------------

W1017385

EDITOR:

KUBOTA FARM & INDUSTRIAL MACHINERY SERVICE, LTD.

64, ISHIZU-KITAMACHI, SAKAI-KU, SAKAI-CITY, OSAKA, 590-0823, JAPAN

PHONE : (81)72-241-1129

FAX : (81)72-245-2484

E-mail : ksos-pub@kubota.co.jp
