

OPERATOR'S MANUAL

KUBOTA FRONT LOADER

MODEL LA272 • LA302
LA352 • LA402

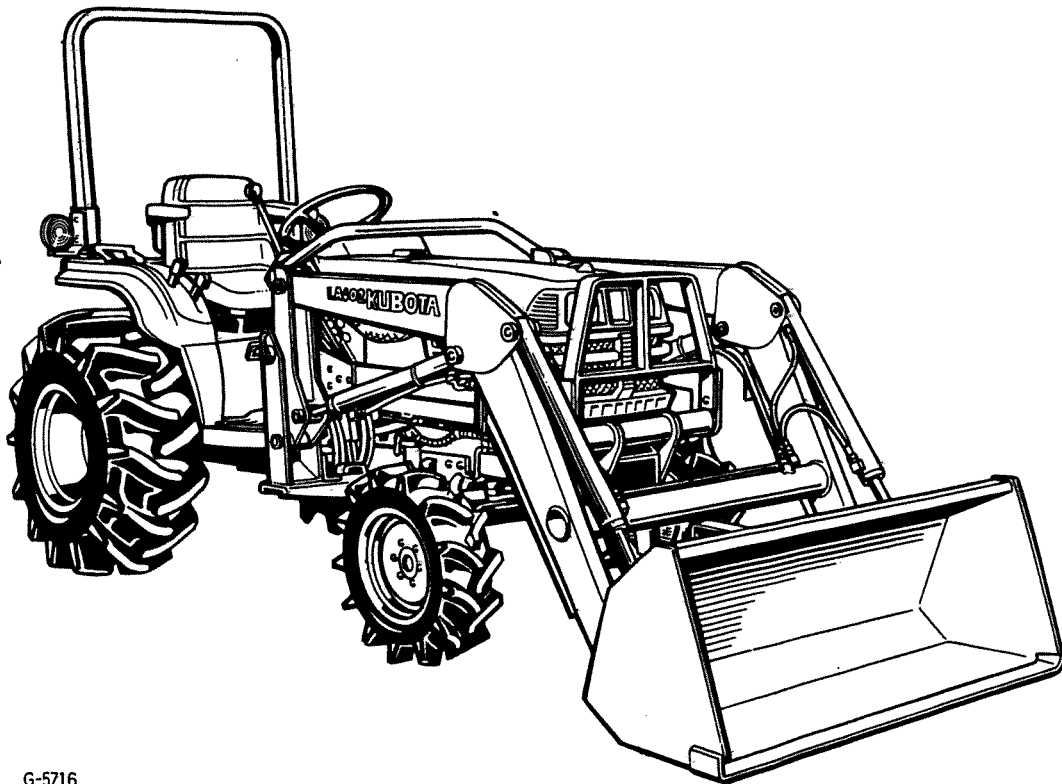

G-5716

READ AND SAVE THIS MANUAL

Kubota



ABBREVIATION LIST

Abbreviations	Definitions
2WD	Two Wheel Drive
4WD	Four Wheel Drive
API	American Petroleum Institute
ASAE	American Society of Agricultural Engineers, USA
ASTM	American Society for Testing and Materials, USA
DIN	Deutsches Institut für Normung, GERMANY
DT	Dual Traction [4WD]
fpm	Feet Per Minute
GST	Glide Shift Transmission
Hi-Lo	High Speed-Low Speed
HST	Hydrostatic Transmission
m/s	Meters Per Second
PTO	Power Take Off
RH/LH	Right-hand and left-hand sides are determined by facing in the direction of forward travel
ROPS	Roll-Over Protective Structure
min ⁻¹ (rpm)	Revolutions Per Minute
S ⁻¹ (r/s)	Revolutions Per Second
SAE	Society of Automotive Engineers, USA
SMV	Slow Moving Vehicle
UDT	KUBOTA UDT fluid (Transmission-hydraulic fluid)



FOREWORD

You are now the proud owner of a KUBOTA Loader. This loader is a product of KUBOTA quality engineering and manufacturing. It is made of fine materials and under a rigid quality control system. It will give you long, satisfactory service. To obtain the best use of your loader, please read this manual carefully. It will help you become familiar with the operation of the loader and contains many helpful hints about loader maintenance. It is KUBOTA'S policy to utilize as quickly as possible every advance in our research. The immediate use of new techniques in the manufacture of products may cause some small parts of this manual to be outdated. KUBOTA distributors and dealers will have the most up-to date information. Please do not hesitate to consult with them.



SAFETY FIRST

This symbol, the industry's "Safety Alert Symbol", is used throughout this manual and on labels on the front loader itself to warn of the possibility of personal injury. Read these instructions carefully. It is essential that you read the instructions and safety regulations before you attempt to assemble or use this unit.



DANGER: Indicates an imminently hazardous situation which, if not avoided, will result in death or serious injury.



WARNING : Indicates a potentially hazardous situation which, if not avoided, could result in death or serious injury.



CAUTION: Indicates a potentially hazardous situation which, if not avoided, may result in minor or moderate injury.

IMPORTANT : Indicates that equipment or property damage could result if instructions are not followed.

NOTE : Gives helpful information.

CONTENTS

▲ SAFE OPERATION	1
SERVICING OF LOADER	5
SPECIFICATIONS	6
SUITABLE TRACTOR.....	6
LOADER SPECIFICATIONS	6
BUCKET SPECIFICATIONS.....	6
DIMENSIONAL SPECIFICATIONS.....	7
OPERATIONAL SPECIFICATIONS	7
PERFORMANCE CHART.....	8
LOADER TERMINOLOGY.....	9
SETTING-UP INSTRUCTIONS	10
PRE-ASSEMBLY.....	10
TRACTOR PREPARATION	11
INSTALLATION INSTRUCTIONS.....	11

Operation Section

PRE-OPERATION CHECK	17
LUBRICATION	17
TRANSMISSION FLUID.....	17
REAR BALLAST	17
TIRE INFLATION	18
TEST OPERATION	18
REMOVING AIR FROM HYDRAULIC SYSTEM.....	18

OPERATING THE LOADER.....	19
FILLING THE BUCKET	19
LIFTING THE LOAD.....	19
CARRYING THE LOAD.....	19
DUMPING THE BUCKET	20
LOWERING THE BUCKET	20
OPERATING WITH FLOAT CONTROL	20
LOADING FROM A BANK	21
PEELING AND SCRAPING.....	21
LOADING LOW TRUCKS OR SPREADERS FROM A PILE	22
BACKFILLING	22
HANDLING LARGE HEAVY OBJECTS.....	23

Maintenance Section

MAINTENANCE	24
LUBRICATION	24
DAILY CHECKS	24
REMOVING THE LOADER.....	26
STORING THE LOADER	27
REINSTALLING THE LOADER	28



SAFE OPERATION

Most loader equipment accidents can be avoided by following simple safety precautions. These safety precautions, if followed at all times, will help you operate your loader safely.

1. Read and understand both the tractor and the loader Operator's Manuals before using the loader.
Lack of knowledge can lead to accidents.
2. For your safety, ROPS with a seat belt is strongly recommended by KUBOTA in almost all applications. If your tractor has a folding ROPS, fold it down only when absolutely necessary and fold it up and lock it again as soon as possible. Do not wear the seat belt when the folding ROPS is down or the fixed ROPS is removed. If you have any questions, consult your local KUBOTA Dealer. Always use seat belt when the tractor is equipped with a ROPS. Never use the seat belt when the tractor is not equipped with a ROPS.
3. Do not lift or carry anybody on the loader, bucket or attachment.
4. Never allow anyone to get under the loader bucket or reach through the boom when the bucket is raised.
5. Do not walk or work under a raised loader bucket or attachment unless it is securely blocked and held in position.
6. When operating on a slope, always operate up and down the slope, never across the slope.
7. Operate the loader from the tractor seat only.
8. For tractor stability and operator's safety, rear ballast must be added to the 3-point hitch and to the rear wheels.
9. To increase stability adjust the rear wheels to the widest setting that is suitable for your application.
10. Move and turn the tractor at low speeds.
11. Carry loader boom at a low position during transport. (You should be able to see over the bucket.)
12. Exercise extra caution when operating the loader with a raised bucket or attachment.
13. Avoid loose fill, rocks and holes. They can be dangerous for loader operation or movement.
14. Be extra careful when working on inclines.
15. Avoid overhead wires and obstacles when loader is raised. Contacting electric lines can cause electrocution.
16. Allow for the loader length when making turns.
17. Gradually stop the loader boom when lowering or lifting.
18. Use caution when handling loose or shiftable loads.
19. When loader work has been completed, lower loader boom to the ground, stop the engine, remove the key and lock the brakes before leaving the tractor seat.
20. Make sure the parked loader is on stands and on a hard, level surface.
21. Operate the loader controls only when properly seated at the controls.
22. Visually check for hydraulic leaks and broken, missing, or malfunctioning parts.
Make necessary repairs before operation.
23. Escaping hydraulic oil under pressure can have sufficient force to penetrate the skin, causing serious personal injury. Do not use hands to search for suspected leaks. If injured by escaping fluid, obtain medical treatment at once.
24. Before disconnecting hydraulic lines, relieve all hydraulic pressure.
25. Do not tamper with the relief valve setting. The relief valve is pre-set at the factory. Changing the setting can cause overloading of the loader and tractor which may result in a serious personal injury.
26. Using loaders for handling large heavy objects, such as large round or rectangular bales, logs and oil drums is not recommended.
27. Handling large heavy objects can be extremely dangerous due to :
 - Danger of rolling the tractor over.
 - Danger of upending the tractor.
 - Danger of the object rolling or sliding down the loader boom onto the operator.
28. If you must perform this sort of work (item 27), protect yourself by :
 - Never lifting the load higher than necessary to clear the ground.
 - Adding rear ballast to the tractor to compensate for the load.
 - Never lifting large object with equipment that may permit it to roll back onto the operator.
 - Moving slowly and carefully, avoiding rough terrain.
29. It is the loader owner's responsibility to be certain anyone operating the loader read this manual first to be aware of the safe way of operating the loader.

- 30. Always wear safety goggles when servicing or repairing the machine.
- 31. When servicing or replacing pins in cylinder ends, bucket, etc., always use a brass drift and hammer. Failure to do so could result in injury from flying metal fragments.
- 32. Replace damaged or illegible safety labels. See following page for required labels.
- 33. Do not modify, alter, or permit anyone else to modify or alter the loader, any of its components, or any loader function without first consulting a KUBOTA Dealer.
- 34. Assemble, remove and reinstall the loader only as directed in this manual. Failure to do this could result in serious personal injury or death.
- 35. When operating another implement on a hillside, be sure to remove the loader to reduce the risk of roll over.
- 36. Never lift or pull any load from any point of the loader with a chain, rope, or cable. Doing so could cause a roll over or serious damage to the loader.
- 37. When a front loader is mounted on the tractor, enter and exit the operator's seat only from left side of the tractor.

DANGER, WARNING AND CAUTION LABELS

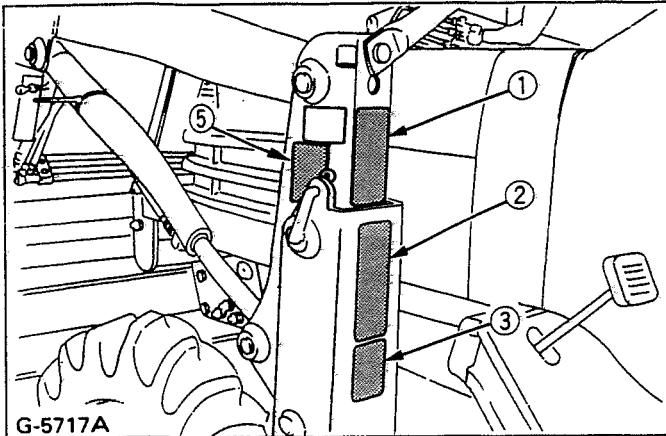

① Part No. 75546-5643-1

▲ DANGER

TO AVOID SERIOUS INJURY OR DEATH CAUSED BY FALLING LOADS :

1. Load on raised bucket or fork can fall or roll back onto operator causing serious injury or death.
2. Use approved clamping and / or guard attachments for handling large, loose or shiftable loads such as bales, posts, sheets of plywood etc.
3. Carry loads as low as possible.

② Part No. 75546-5641-5

▲ DANGER

TO AVOID SERIOUS INJURY OR DEATH CAUSED BY ROLLOVERS :

1. ROPS and a fastened seat belt are strongly recommended in almost all applications. Foldable ROPS should be in upright and locked position if equipped.
2. Adjust rear wheels to the widest setting that is suitable for the work.
3. Add recommended wheel ballast and rear weight for stability.
4. DO NOT drive on steep slopes or unstable surfaces.
5. Carry loader arms at low position during transport. Move and turn tractor at slow speeds.

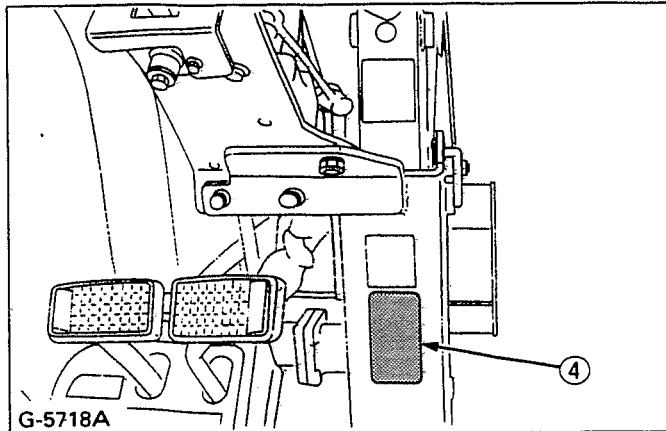

④ Part No. 75546-5645-1

▲ CAUTION

TO AVOID PERSONAL INJURY :

1. Observe safety precautions in loader and tractor Operator's Manual.
2. Operate the loader from tractor seat only.
3. Keep children, others and livestock away when operating loader and tractor.
4. Avoid holes, loose ground, and rocks which may cause tractor / loader to tip.
5. When parking or storing, choose flat and hard ground. Lower the bucket to the ground, set brakes and remove key before leaving tractor.
6. Before disconnecting hydraulic lines, relieve all hydraulic pressure.

③ Part No. 75567-5642-2

▲ DANGER

TO AVOID SERIOUS INJURY OR DEATH CAUSED BY CONTACT WITH ELECTRIC LINES:

- Check overhead clearance.

⑤ Part No. 75546-5644-1 (Both sides)

▲ WARNING

TO AVOID INJURY FROM FALLS OR BEING CRUSHED :

1. DO NOT stand or work under raised loader or bucket.
2. DO NOT use loader as a work platform.
3. NEVER connect chain, cable or rope to loader bucket while operating loader.

CARE OF DANGER, WARNING AND CAUTION LABELS

1. Keep danger, warning and caution labels clean and free from obstructing material.
2. Clean danger, warning and caution labels with soap and water, dry with a soft cloth.
3. Replace damaged or missing danger, warning and caution labels with new labels from your local KUBOTA Dealer.
4. If a component with danger, warning and caution label (s) affixed is replaced with new part, make sure new label (s) is (are) attached in the same location (s) as the replaced component.
5. Mount new danger, warning and caution labels by applying on a clean dry surface and pressing any bubbles to outside edge.



SERVICING OF LOADER

This manual provides safety, set-up, operation, maintenance, removing, storing and reinstalling instructions for your new LA272, LA302, LA352 and LA402 loaders.

Your loader has been designed to give many years of satisfactory service. Successful operation and long life of the loader depends, of course, on proper operation and care. Please read this manual carefully and follow the instructions. Correct operation and maintenance will save much time and expense.

OBSERVE and FOLLOW all CAUTION instructions to help prevent personal injury and damage to the loader.

The reference to left hand and right hand used in this manual refers to the position when standing at the rear of the unit and facing forward.

If at any time, you have a service problem with your loader or need new parts, contact your local KUBOTA Dealer. Your dealer will need the loader model number and serial number to give you prompt, efficient service. The serial number is located on the outside of the side frame LH.

KUBOTA LOADER

Model LA402
 Serial Number 14402
 Date of Purchase 11/16/01
 Name of Dealer Pauley Equipment

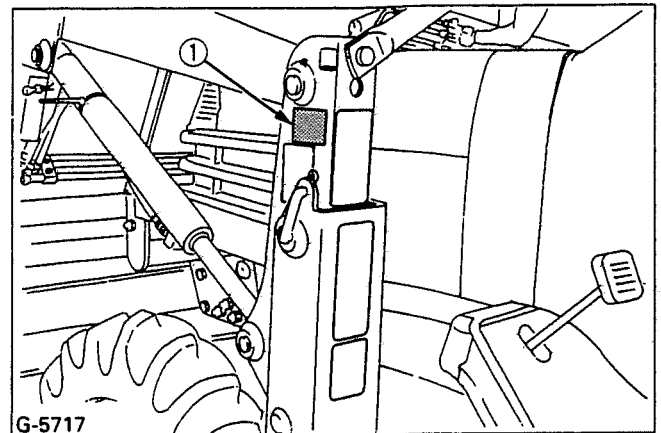

G-5717

(1) Serial No.

SPECIFICATIONS

SUITABLE TRACTOR

B7400 model : **LA272**

B7500 model : **LA272, LA302**

B2410 model : **LA352**

B2710, B2910 HST models : **LA402**

LOADER SPECIFICATIONS

Loader model		LA272	LA302	LA352	LA402
Tractor model		B7400	B7500	B2410	B2710, B2910
Wheel base (WB)	mm(in.)	1500 (59.1)	1500 (59.1)	1500 (59.1)	1666 (65.6)
Front tires		6-12	6-12	7-12	7-12
Rear tires		8.3-16	9.5-16	11.2-16	12.4-16
Boom cylinder	Bore	mm(in.)	38.1 (1-1/2)	38.1 (1-1/2)	44.5 (1-3/4)
	Stroke	mm(in.)	307 (12.1)	307 (12.1)	289 (11.4)
Bucket cylinder	Bore	mm(in.)	38.1 (1-1/2)	38.1 (1-1/2)	44.5 (1-3/4)
	Stroke	mm(in.)	330 (13.0)	330 (13.0)	330 (13.0)
Control Valve	3 Position bucket control valve type	One Detent Float Position, Power Beyond Circuit			
	4 Position bucket control valve type	One Detent Float Position, Two Stage Bucket Dump, Power Beyond Circuit			
Rated flow	L/m(GPM)	14.6 (3.9)	16.6 (4.4)	16.6 (4.4)	24.4 (6.4)
Maximum pressure	kg/cm ² (psi)	141 (2000)	155 (2200)	141 (2000)	141 (2000)
Net weight (Approximate)	kg(lbs.)	208 (460)	216 (475)	226 (500)	280 (617)

BUCKET SPECIFICATIONS

Loader model		LA272, LA302	LA352	LA402	LA402(Option)
Model		Square 48	Square 50	Square 54	Square 60 LM
Width	mm(in.)	1220 (48.0)	1270 (50.0)	1370 (54.0)	1525 (60.0)
Depth (L)	mm(in.)	465 (18.4)	495 (19.4)	485 (19.1)	525 (20.6)
Height (M)	mm(in.)	480 (18.9)	485 (19.1)	525 (20.6)	540 (21.2)
Length (N)	mm(in.)	500 (19.6)	525 (20.6)	530 (20.8)	570 (22.5)
Capacity	Struck	m ³ (cu.ft.)	0.15 (5.2)	0.16 (5.5)	0.19 (6.7)
	Heaped	m ³ (cu.ft.)	0.17 (6.2)	0.18 (6.5)	0.23 (8.1)
Weight	kg(lbs.)	54 (120)	62 (137)	79 (175)	82 (180)

DIMENSIONAL SPECIFICATIONS

Loader model			LA272	LA302	LA352	LA402
(A)	Maximum lift height to pivot pin	mm(in.)	1770 (69.7)	1765 (69.5)	1770 (69.7)	2090 (82.3)
(B)	Maximum lift height under level bucket	mm(in.)	1635 (64.4)	1630 (64.2)	1630 (64.2)	1940 (76.4)
(C)	Clearance with bucket dumped	mm(in.)	1310 (51.6)	1320 (52.0)	1310 (51.6)	1665 (65.5)
(D)	Reach at maximum lift height	mm(in.)	680 (26.8)	645 (25.4)	635 (25.0)	660 (26.0)
(E)	Maximum dump angle	deg.	45	45	45	40
(F)	Reach with bucket on ground	mm(in.)	1280 (50.4)	1295 (51.0)	1320 (52.0)	1375 (54.1)
(G)	Bucket roll-back angle	deg.	24	24	24	26
(H)	Digging depth	mm(in.)	80 (3.1)	80 (3.1)	80 (3.1)	135 (5.3)
(J)	Overall height in carrying position	mm(in.)	1150 (45.3)	1160 (45.7)	1160 (45.7)	1195 (47.0)

OPERATIONAL SPECIFICATIONS

Loader model		LA272	LA302	LA352	LA402	
Lift capacity to maximum height (Bucket bottom mid point)		kg(lbs.)	270 (595)	300 (660)	350 (770)	400 (880)
(U)	Lift capacity to maximum height-at pivot pin	kg(lbs.)	310 (685)	350 (770)	420 (925)	480 (1060)
(V)	Lift capacity to maximum height	kg(lbs.)	225 (495)	250 (550)	305 (670)	345 (760)
(W)	Lift capacity to 1.5m (59in.) height-at pivot pin	kg(lbs.)	345 (760)	390 (860)	470 (1035)	600 (1325)
(X)	Lift capacity to 1.5m (59in.) height	kg(lbs.)	255 (560)	290 (640)	350 (770)	455 (1005)
(Y)	Breakout force-at pivot pin	N(lbs.)	6280 (1410)	7010 (1575)	8380 (1885)	10250 (2305)
(Z)	Breakout force	N(lbs.)	4460 (1005)	4990 (1120)	5940 (1335)	7500 (1685)
(VV)	Bucket rollback force at maximum height	N(lbs.)	5000 (1125)	5540 (1245)	8430 (1895)	10450 (2350)
(XX)	Bucket rollback force at 1.5m (59in.) lift height	N(lbs.)	5440 (1225)	6030 (1355)	9120 (2050)	12540 (2820)
(ZZ)	Bucket rollback force at ground line	N(lbs.)	4510 (1015)	4950 (1115)	7450 (1675)	10540 (2370)
Raising time		sec.	3.3	2.7	3.1	3.2
Lowering time		sec.	2.5	2.2	2.5	2.4
Bucket dumping time		sec.	1.9	1.6	1.9	1.9
Bucket rollback time		sec.	2.2	1.8	2.5	2.4

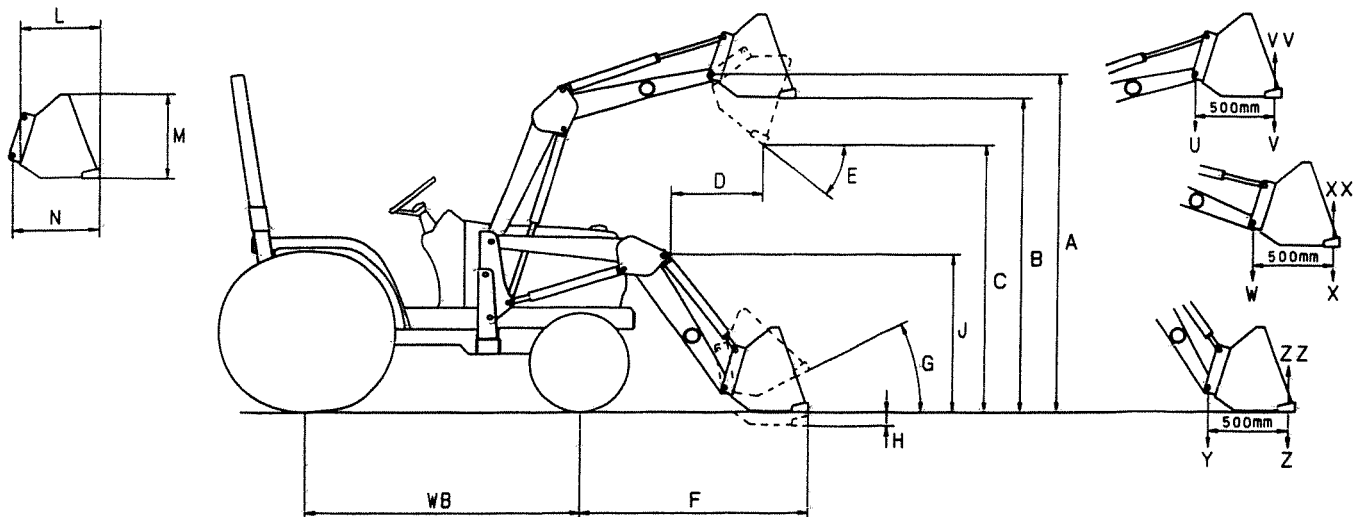

PERFORMANCE CHART

◆ LA272

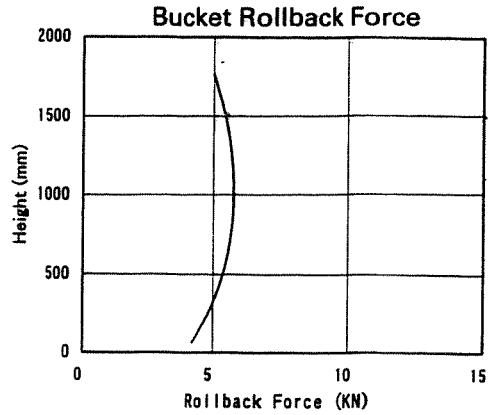
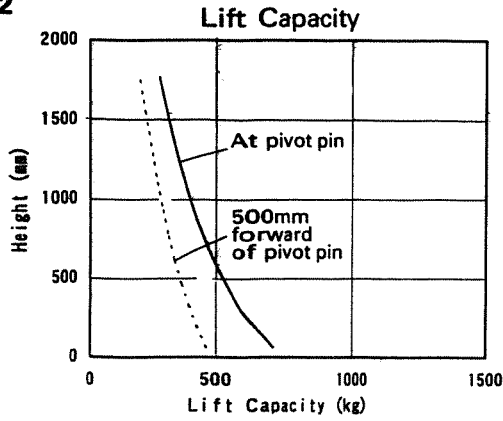

◆ LA302

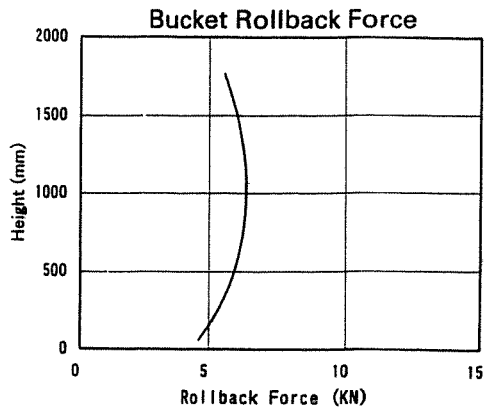
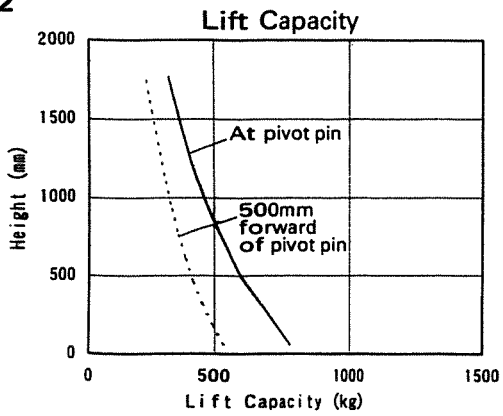

◆ LA352

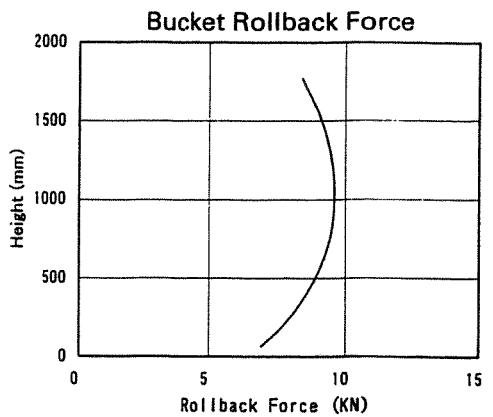
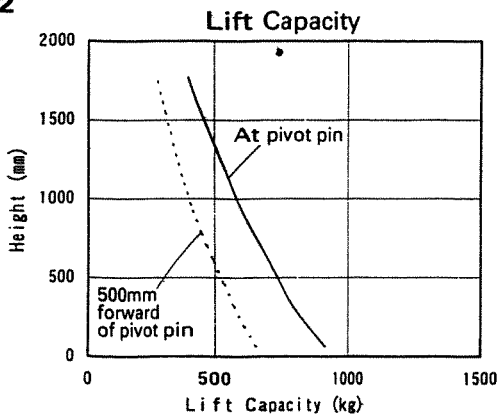

◆ LA402

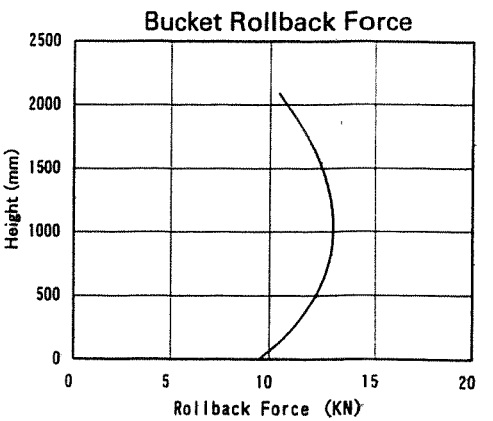
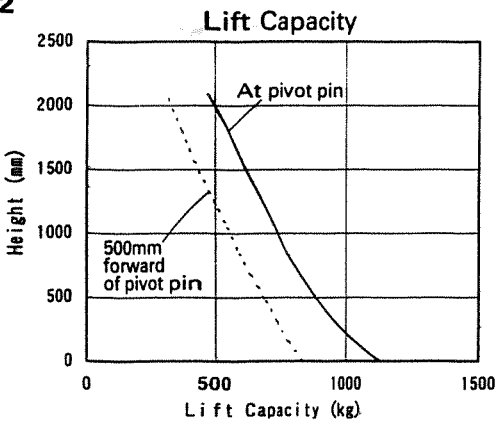

LOADER TERMINOLOGY

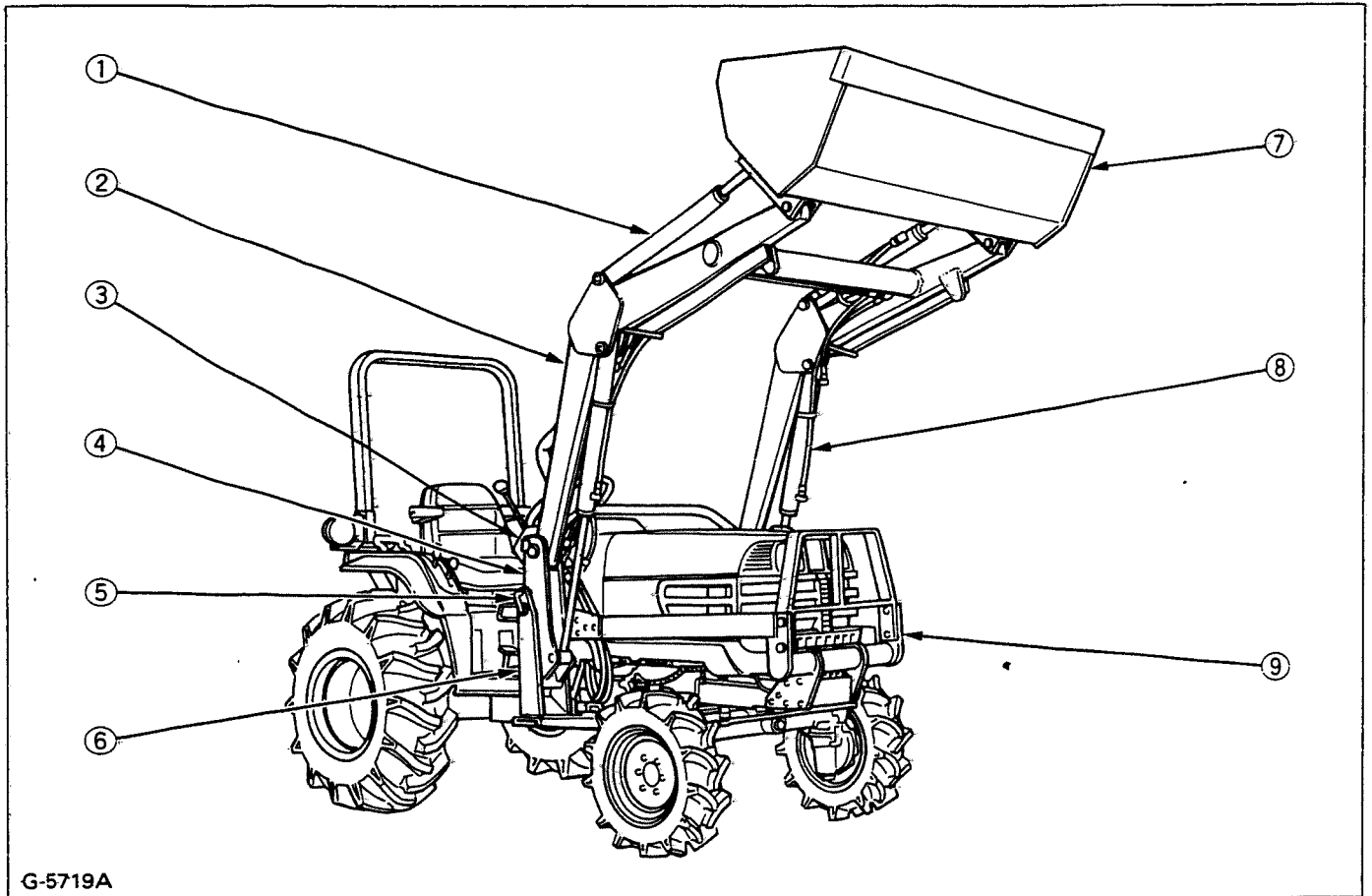

G-5719A

- (1) Bucket cylinder
- (2) Boom
- (3) Hydraulic control valve
- (4) Side frame
- (5) Mounting pin
- (6) Main frame

- (7) Bucket
- (8) Boom cylinder
- (9) Brace

SETTING-UP INSTRUCTIONS

PRE-ASSEMBLY

Remove all loader components. Referring to the illustration, insure that all components have been included.

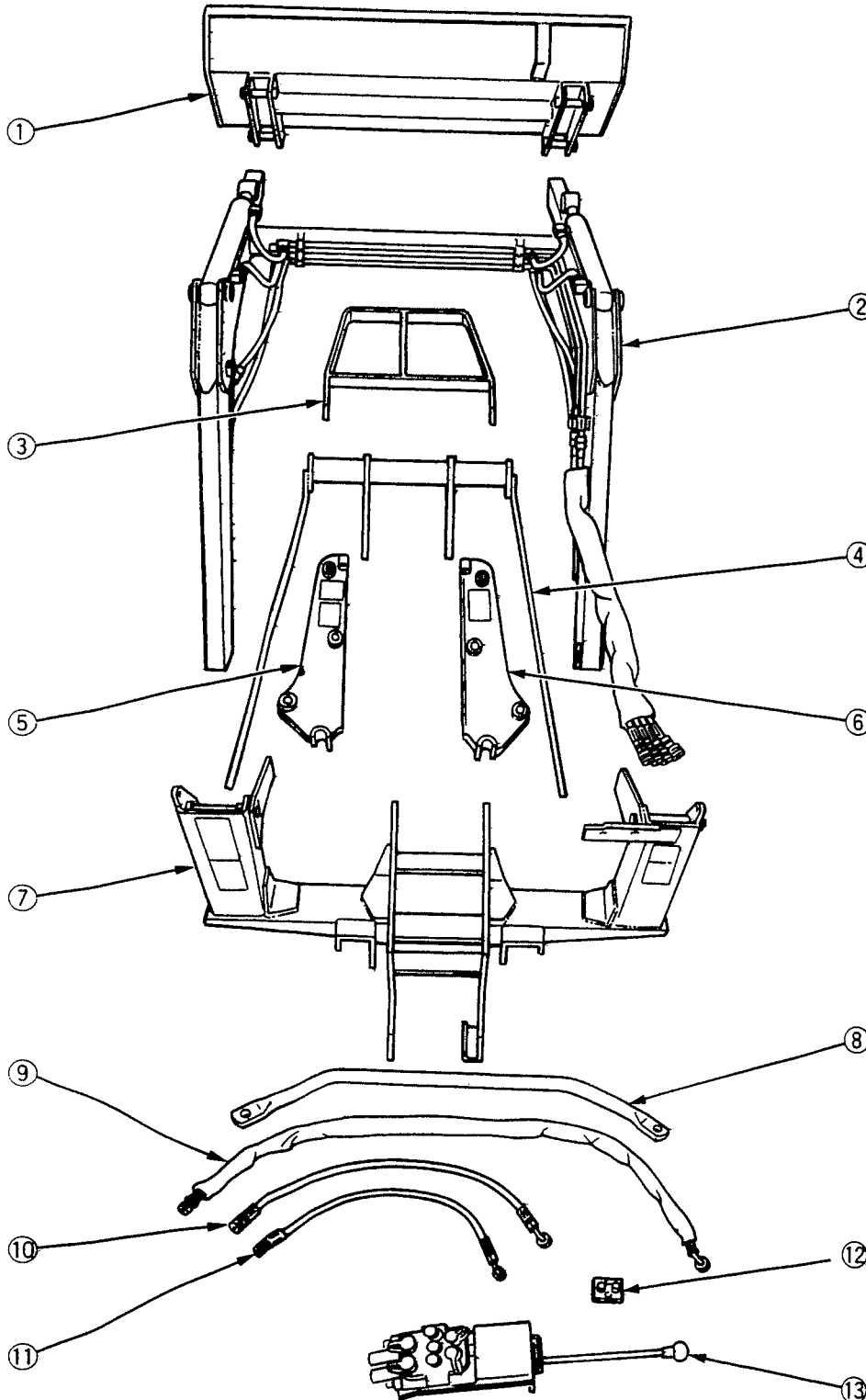

- (1) Bucket (with 4 pins)
- (2) Boom assembly
- (3) Front guard (LA272 : option)
- (4) Brace
- (5) Side frame LH
- (6) Side frame RH
- (7) Main frame
- (8) Side frame connector
- (9) Hose 7, 1450 mm (57.1 in.)
[LA272, LA302, LA352, without sleeve]
Hose 7, 1486 mm (58.5 in.)
[LA402 with sleeve]
- (10) Hose 5, 876 mm (34.5 in.)
- (11) Hose 6, 749 mm (29.5 in.)
- (12) Hydraulic block
- (13) Control valve assembly

TRACTOR PREPARATION

1. Remove the mid mount mower from the tractor if equipped.
2. Locate the tractor on a firm level surface. Lower the implement to the ground, set the parking brake and stop the engine.

INSTALLATION INSTRUCTIONS

IMPORTANT:

- This loader has both standard and metric fasteners. Insure that the proper fasteners are placed in the correct locations. Metric fasteners that are marked 8.8 mount to the tractor. The bolts that go only in the loader are standard.
- Do not tighten any bolts firmly until most components are attached to the tractor.
- Before finally tightening all mounting hardware, start the engine and apply down pressure to the bucket until the loader raises the front wheels slightly, and make sure that the mounting pins can be rotated easily. Torque all bolts and nuts in this position.
- To avoid damage to hoses, adjust all connections to route hoses away from sharp edges.

Hydraulic Lines

1. Remove the cover of the hydraulic block on the tractor.
2. Install the loader hydraulic block to the tractor hydraulic block.
Tightening torque : 2. 35 kgf-m (17 ft-lbs)

NOTE

- Reuse the bolts fastening the hydraulic block cover.

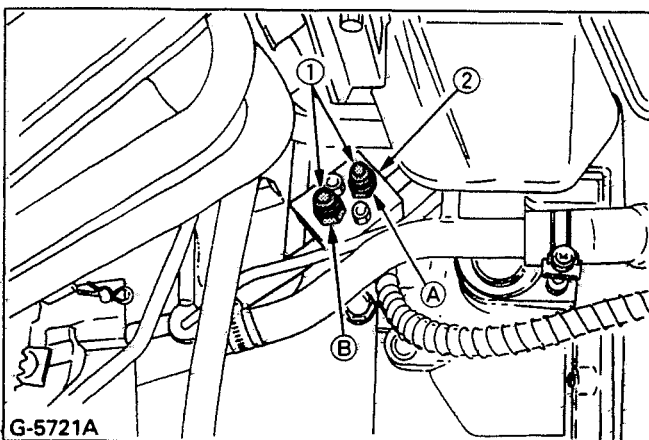

- (1) Adapters (A) Pump port
(2) Hydraulic block (B) Power beyond port

3. Remove the plug from the transmission case. Install the return fitting to the transmission case.

IMPORTANT

- Use teflon tape on the tapered thread of the return fitting.

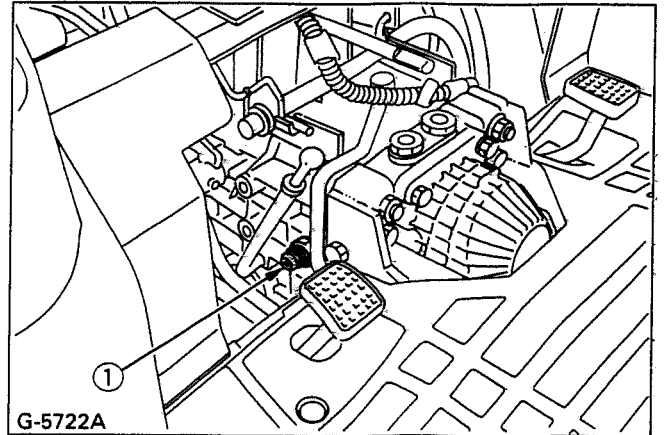

(1) Return fitting

4. Connect Hose 7 to the return fitting as shown.

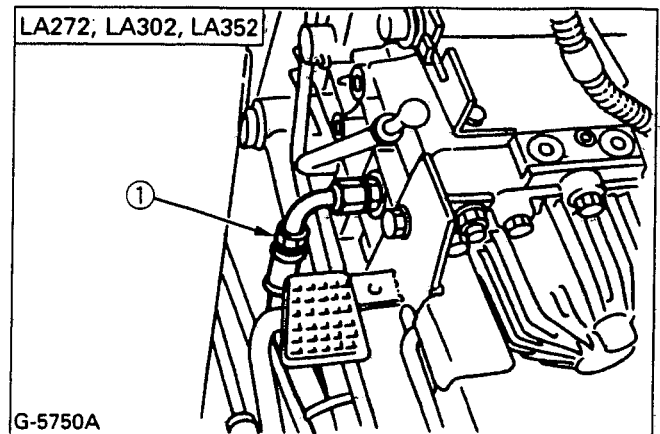

(1) Hose 7 (1450mm, 57.1in.)

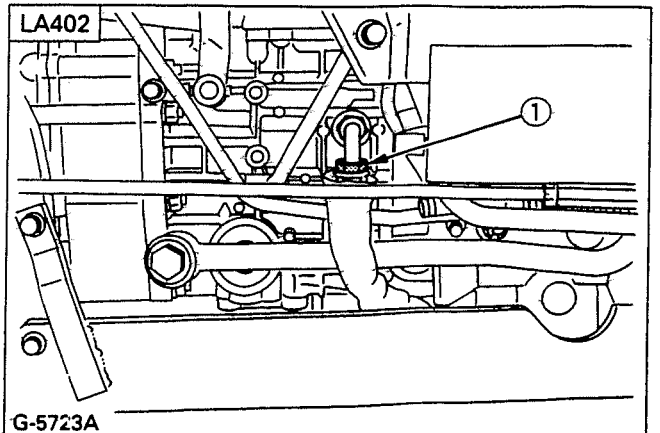

(1) Hose 7 with sleeve (1486mm, 58.5in.)

■ Main Frame, Brace and Front Guard

1. Remove the subframe brackets from the tractor. [LA402 only]

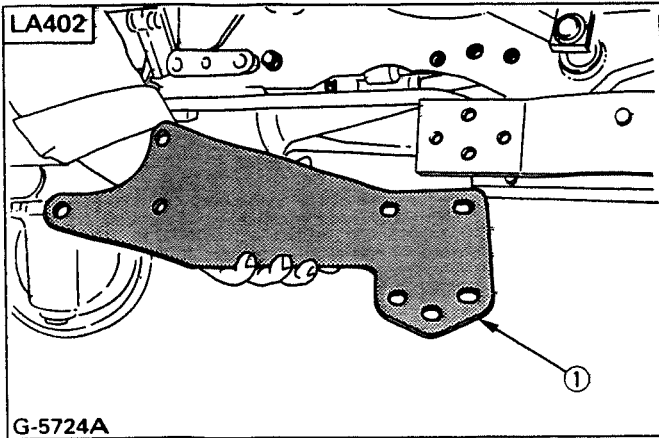

(1) Subframe bracket

2. Turn the direction of the clamp for the drive shaft cover 90 degrees so that the clamp does not touch the loader main frame.

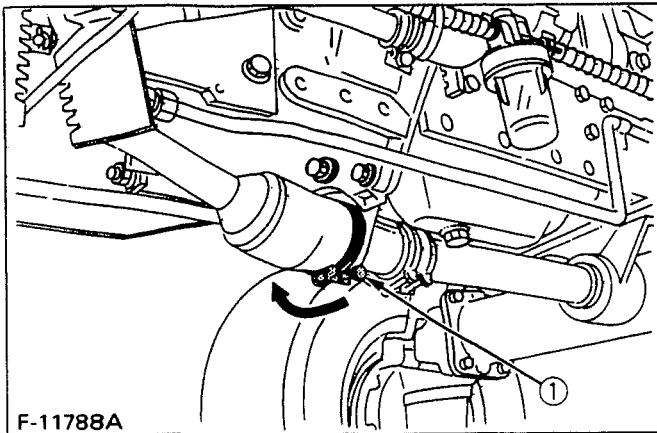

(1) Clamp

3. Attach the main frame to the tractor as shown.

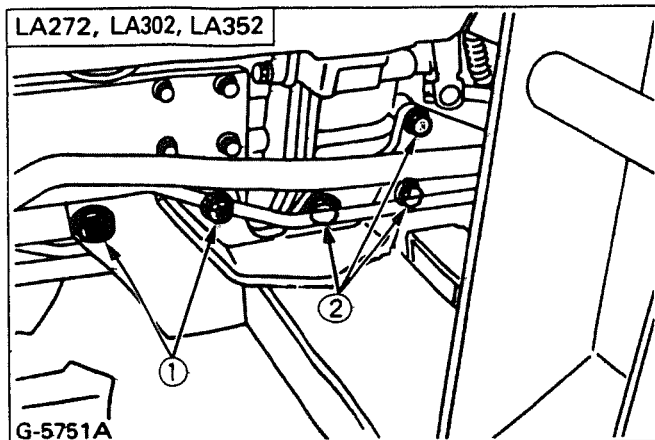

- (1) 4-M14 x 35 bolts
4-9/16 spring lock washers
- (2) 6-M12 x 35 bolts (Pitch 1.75)
6-M12 spring lock washers

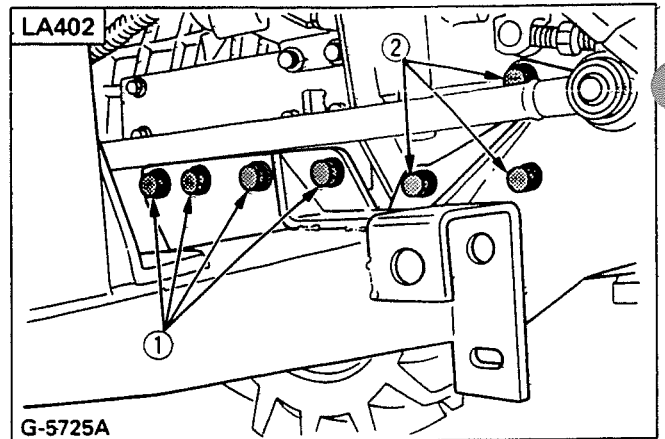

- (1) 8-M14 x 35 bolts
8-9/16 spring lock washers
- (2) 6-M12 x 35 bolts (Pitch 1.75)
6-M12 spring lock washers
6-1/2 hardened plain washers

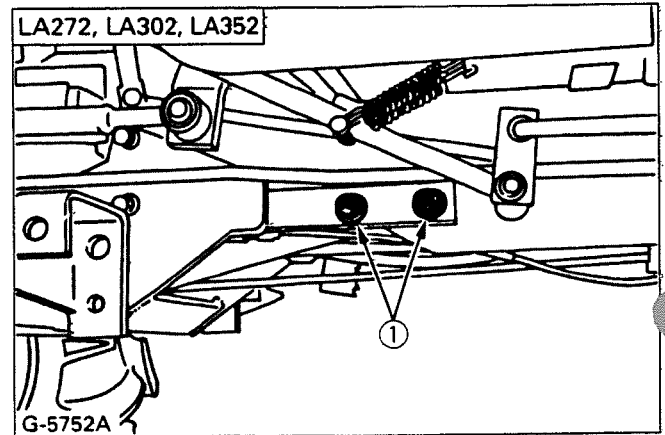

- (1) 4-M12 x 30 bolts (Pitch 1.25)
4-M12 spring lock washers
4-1/2 plain washers

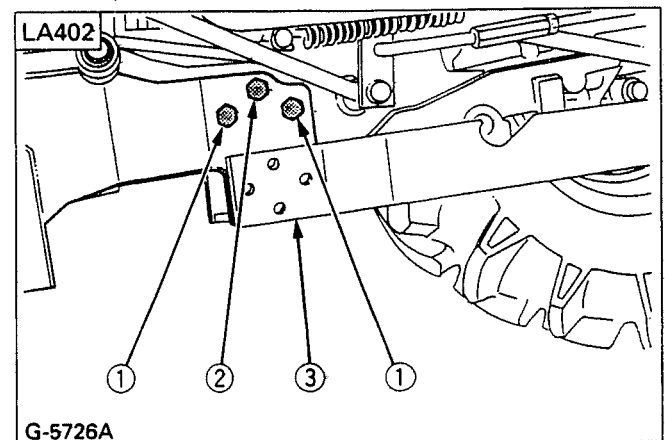

- (1) 4-M12 x 30 bolts (Pitch 1.25)
4-M12 spring lock washers
4-1/2 hardened plain washers
- (2) 2-M14 x 35 bolts (Pitch 1.50)
2-9/16 spring lock washers
2-9/16 hardened plain washers
- (3) Subframe

4. Connect the main frame to the subframe on the tractor. [LA402 only]

NOTE

- Reuse the fasteners connecting the subframe brackets and the subframes.
- Install all the flange bolts for the subframes from the inside.

5. Attach the brace to the tractor front frame as shown. (Do not tighten bolts firmly until all other related components have been installed.)

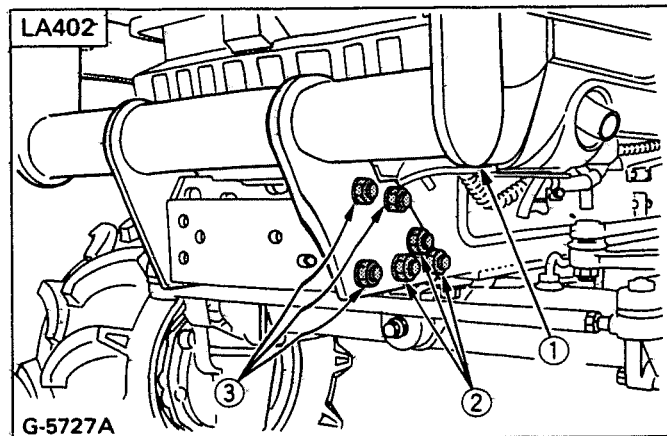
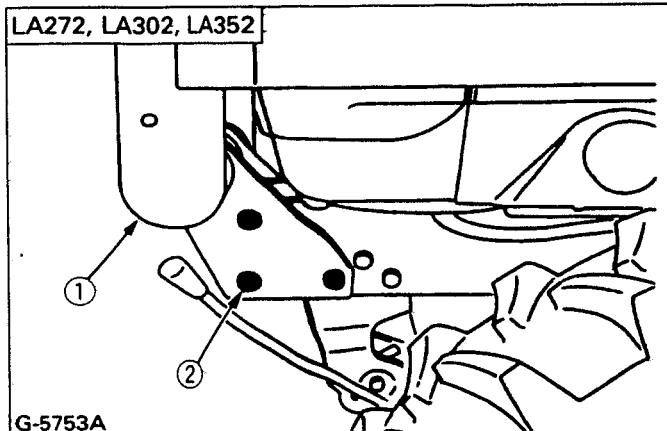

- (1) Brace
 (2) 6-9/16-18 UNF x 1 3/4 Bolts
 6-9/16-18 UNF nuts
 6-9/16 spring lock washers
 (3) 6-9/16-18 UNF x 1 1/2 Bolts
 6-9/16-18 UNF nuts
 6-9/16 spring lock washers

6. Attach the rear ends of the brace to the main frame as shown.

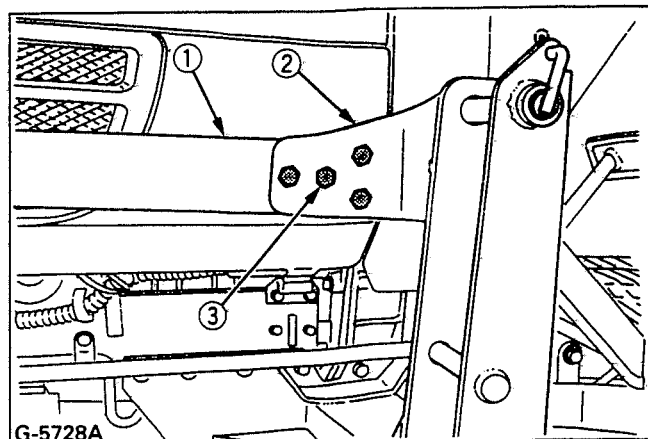

- (1) Brace
 (2) Main frame
 (3) 8-9/16-18 UNF x 1 1/2 bolts
 8-9/16-18 UNF nuts
 8-9/16 spring lock washers

IMPORTANT

- Install all the bolts on each brace from the outside.

7. Attach the front guard to the front loader brace.

NOTE

- The cushion on the front guard should be facing the tractor. [LA352, LA402]
- The front guard is an option for LA272.

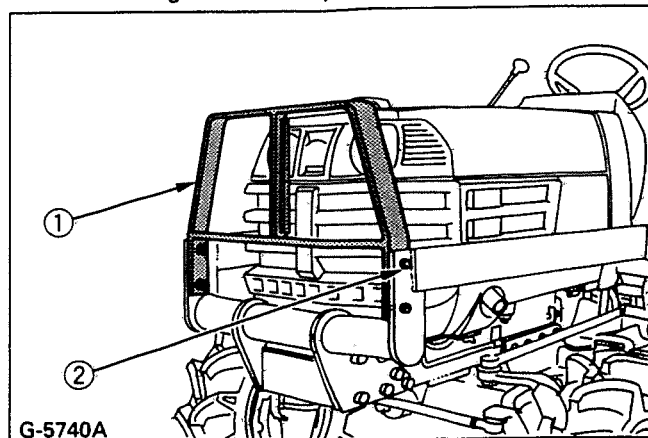

- (1) Front guard
 (2) 4-1/2-20 UNF x 1 1/2 bolts
 4-1/2-20 UNF nuts
 4-1/2 spring lock washers

Hydraulic Valve and Hoses

1. Connect Hose 5 (876 mm, 34.5 in.) to the power beyond port of the hydraulic block.
2. Connect Hose 6 (749 mm, 29.5 in.) to the pump port of the hydraulic block.

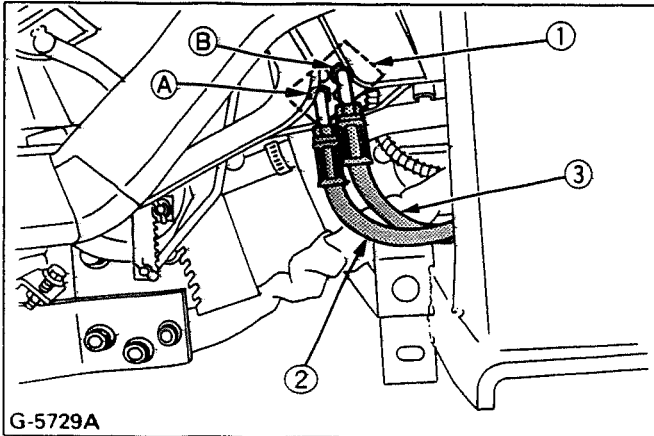

- G-5729A
- (1) Hydraulic block
(2) Hose 5
(3) Hose 6
- (A) Power beyond port
(B) Pump port

3. Attach the valve assembly to the main frame as shown.

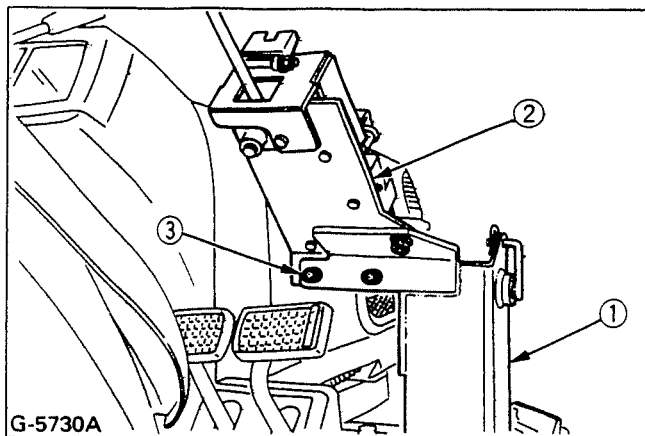

- G-5730A
- (1) Main frame
(2) Valve assembly
(3) 3-1/2-13 UNC x 1 1/4 bolts
3-1/2 -13 UNC nuts
3-1/2 spring lock washers

4. Connect Hose 5 (876 mm, 34.5 in.) to the power beyond port of the hydraulic control valve.
5. Connect Hose 6 (749 mm, 29.5 in.) to the pump port of the hydraulic control valve.
6. **[LA272, LA302, LA352]**
Route Hose 7 (1450mm, 57.1in.) from the return fitting as shown and connect it to the tank port of the hydraulic control valve. Route Hose 7 above the mower linkage, and clear of all moving parts. Clamp Hose 7 with two plastic ties as shown.

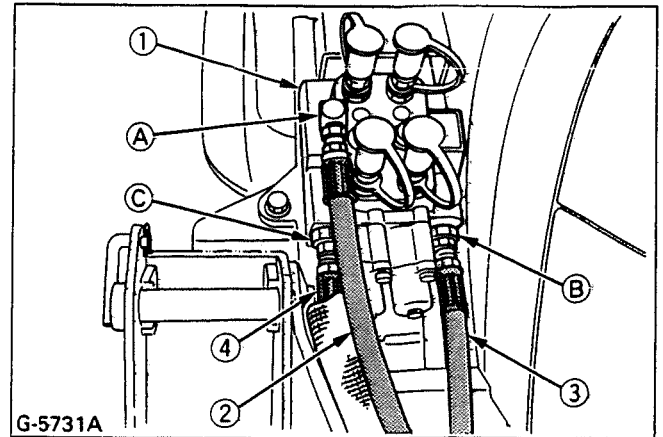

- G-5731A
- (1) Hydraulic control valve
(2) Hose 5
(3) Hose 6
(4) Hose 7
- (A) Power beyond port
(B) Pump port
(C) Tank port

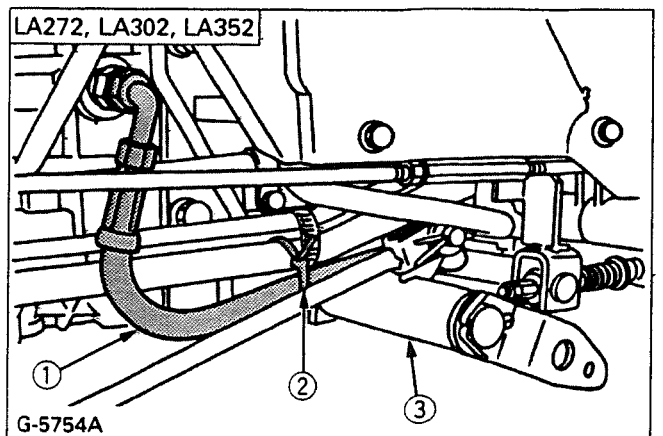

- G-5754A
- (1) Hose 7
(2) Plastic tie
(3) Mower linkage

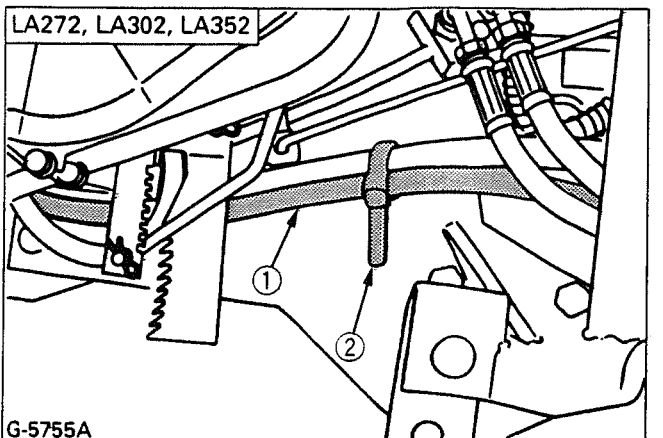

- G-5755A
- (1) Hose 7
(2) Plastic tie

[LA402]

Route Hose 7 (1486 mm, 58.5 in.) with the nylon sleeve from the return fitting as shown and connect it to the tank port of the hydraulic control valve. Route Hose 7 on the hose support plate and clear of all moving parts as shown.

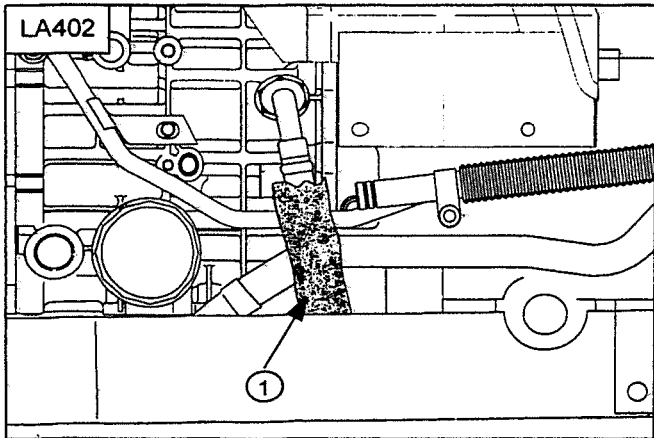

(1) Hose 7

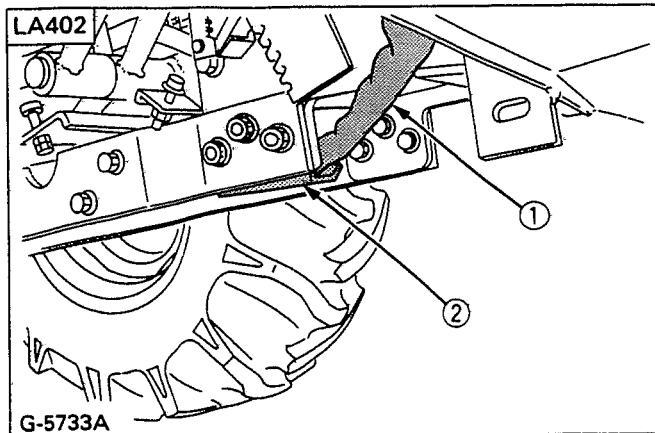

(1) Hose 7
(2) Hose support plate

7. Clamp three hoses with plastic tie as shown.

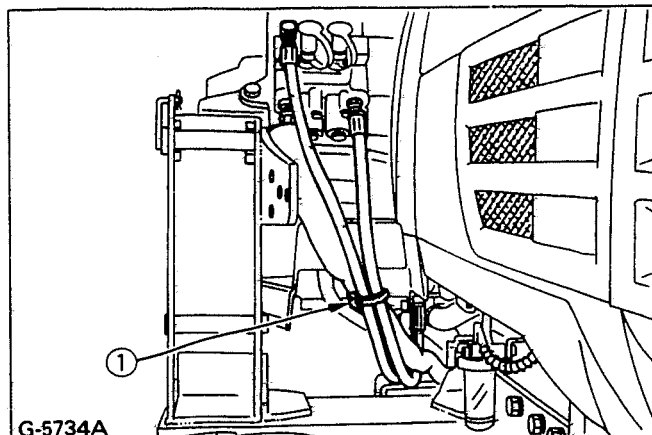

(1) Plastic tie

Side Frames, Boom Assembly and Bucket

1. Set the side frame LH and RH onto the main frame. Install the mounting pins and secure them with the spring pins.

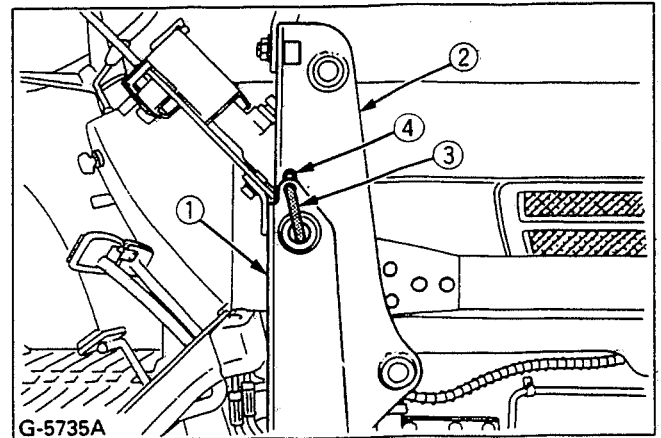

(1) Main frame
(2) Side frame
(3) Mounting pin
(4) Spring pin

2. Attach the boom assembly to the side frames as shown.

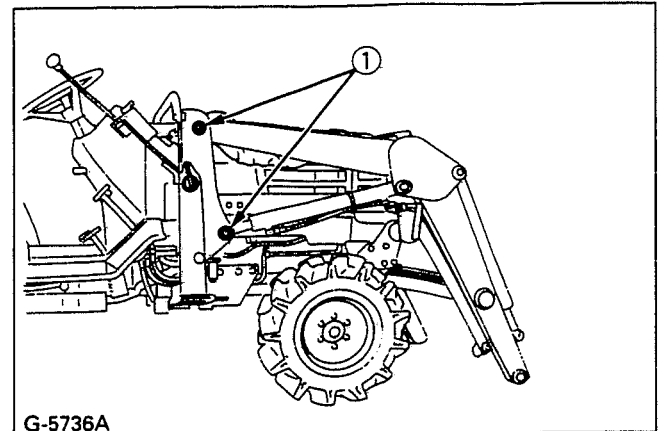

(1) [LA272, LA302]
4 - Pin 4
4 - 3/16 x 1 3/4 cotter pins
[LA352, LA402]
4 - Pin 2
4-1/4-20 UNC x 2-1/4 bolts
4-1/4-20 UNC locking nuts

3. Attach the bucket to the boom.

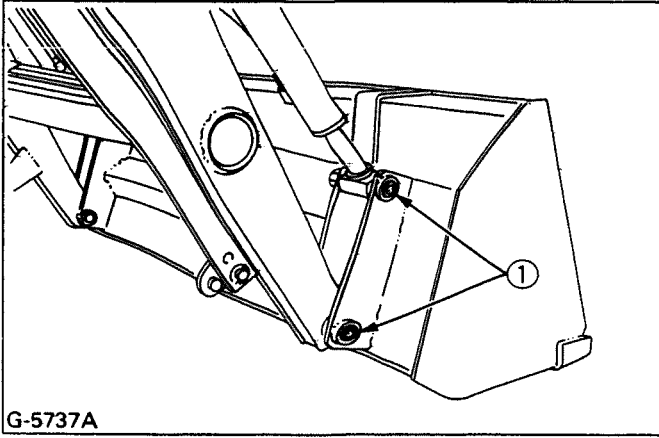

(1) [LA272, LA302]

4 - Pin 4

4 - 3/16 x 1 3/4 cotter pins

(1) [LA352, LA402]

4 - Pin 3

4-1/4-20 UNC x 2-1/4 bolts
4-1/4-20 UNC locking nuts

■ Side Frame Connector

Attach the side frame connector to the top of the side frame as shown.

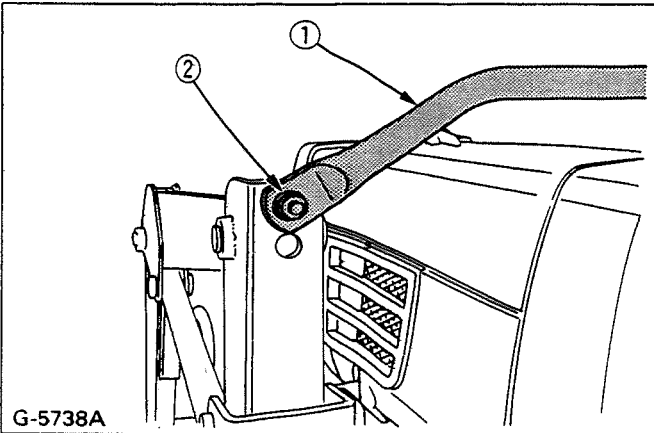

(1) Side frame connector

(2) 2-9/16-18 UNF x 1 1/4 bolts

2-9/16-18 UNF nuts

2-9/16 spring lock washers

■ Hydraulic Hoses

Connect four hoses with quick couplers to the nipples on the control valve as indicated with color marks.

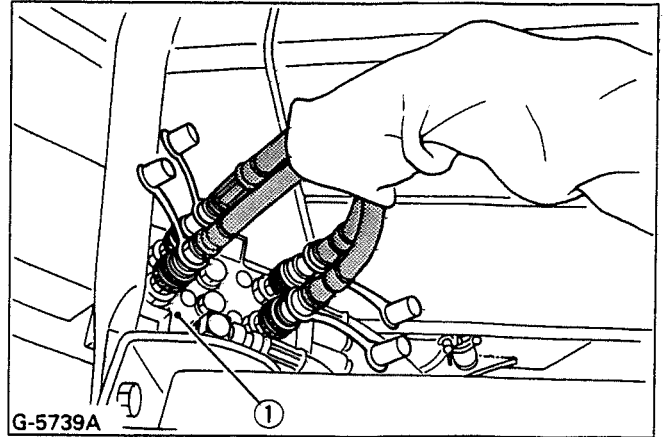

(1) Control valve

■ Tightening Bolts and Nuts

Tighten all bolts and nuts in the following order to the required torque.

NOTE:

- Before finally tightening all mounting hardware, start the engine and apply down pressure to the bucket until the loader raises the front wheels slightly, and make sure that the mounting pins can be rotated easily. Tighten all bolts and nuts in this position.

Sequence	Location	Bolt / Nut		Required Torque kgf-m (ft-lbs)	
		LA272 LA302 LA352	LA402	LA272 LA302 LA352	LA402
1	Main frame (Clutch housing)	6-M12 Bolts		8.5 (61)	
2	Main frame (Front axle frame)	4-M14 Bolts	8-M14 Bolts	15.0 (108)	
3	Main frame (Center frame)	4-M12 Bolts		10.0 (72)	
4		-	2-M14 Bolts	-	17.0 (123)
5	Main frame (Sub frame)	-	6-M12 Nuts	-	8.5 (61)
6	Brace	14-9/16 Nuts	20-9/16 Nuts	18.0 (130)	
7	Side frame connector	2 - 9/16 Nuts		15.0 (108)	

PRE-OPERATION CHECK

LUBRICATION

Lubricate all grease fittings with SAE multipurpose grease.

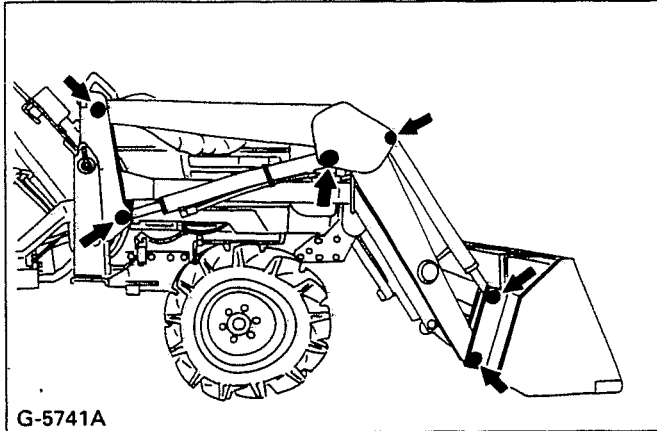

TRANSMISSION FLUID

Check tractor transmission fluid level. Add fluid if necessary. Refer to the tractor's Operator's Manual for instructions and proper fluid. Repeat this check after purging air from the system. At that time, it will be necessary to add transmission fluid.

REAR BALLAST



CAUTION

To avoid personal injury:

- For tractor stability and operator's safety, rear ballast should be added to the rear of the tractor in the form of 3-point counter weight and rear wheel ballast. The amount of rear ballast will depend on the application.

Implement as Counter Weight	
4' Land Scraper	Approx. 225 kg (495 lbs.)
Rear Blade	
Rotary Tiller	Approx. 200 kg (440 lbs.)
Backhoe	

Liquid Ballast in Rear Tires

Water and calcium chloride solution provides a safe and economical ballast. Used properly, it will not damage tires, tubes or rims. The addition of calcium chloride is recommended to prevent the water from freezing. This method of weighting the wheels is fully approved by the tire manufacturers. See your tire dealer for this service.

Liquid weight per tire (75 Percent filled)

Tire sizes	8.3-16	9.5-16	11.2-16	12.4-16
Slush free at -10°C (14°F)				
Solid at -30°C (-22°F)	35 kg	54 kg	70 kg	85 kg
[Approx. 1 kg (2 lbs.) CaCl ₂ per 4 L (1 gal) of water]	(77 lbs.)	(119 lbs.)	(155 lbs.)	(187 lbs.)
Slush free at -24°C (-11°F)				
Solid at -47°C (-52°F)	37 kg	57 kg	74 kg	89 kg
[Approx. 1.5 kg (3.5 lbs.) CaCl ₂ per 4 L (1 gal) of water]	(82 lbs.)	(126 lbs.)	(163 lbs.)	(196 lbs.)
Slush free at -47°C (-52°F)				
Solid at -52°C (-62°F)	39 kg	60 kg	78 kg	94 kg
[Approx. 2.25 kg (5 lbs.) CaCl ₂ per 4 L (1 gal) of water]	(86 lbs.)	(132 lbs.)	(172 lbs.)	(207 lbs.)

IMPORTANT:

- Do not fill tires with water or solution more than 75% of capacity (to the level of valve stem at 12 o'clock position).

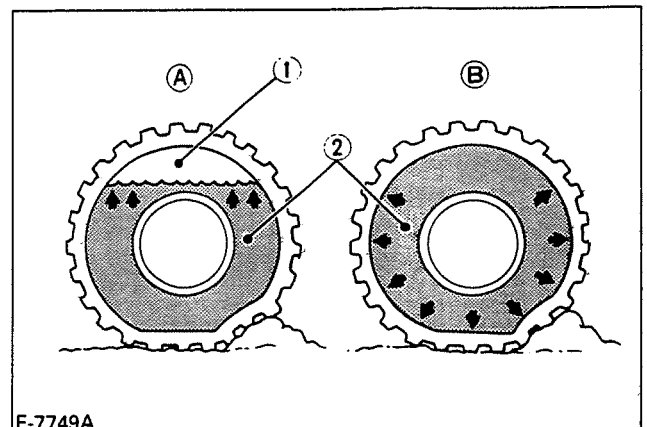

F-7749A

- (1) Air (A) Correct: 75% Full
Air compresses like a cushion
- (2) Water (B) Incorrect: 100% Full
Water cannot be compressed

NOTE:

- When mounting a heavy rear implement, liquid in the tire may not be required.

IMPORTANT:

- Do not add liquid ballast or any other weights to the front tires.

TIRE INFLATION

Insure that the tractor tires are properly inflated. Refer to the tractor's Operator's Manual for optional tires.

Inflation pressure

	Tire Sizes	Inflation Pressure
Rear	8.3-16, 4PR	140kPa (1.4kgf/cm ² , 20psi)
	9.5-16, 4PR	140kPa (1.4kgf/cm ² , 20psi)
	11.2-16, 4PR	130kPa (1.3kgf/cm ² , 18psi)
	12.4-16, 4PR	120kPa (1.2kgf/cm ² , 17psi)
Front	5.00-10, 4PR	270kPa (2.8kgf/cm ² , 40psi)
	6-12, 4PR	200kPa (2.0kgf/cm ² , 28psi)
	6.50-10, 4PR	200kPa (2.0kgf/cm ² , 28psi)
	7-12, 4PR	170kPa (1.7kgf/cm ² , 24psi)

TEST OPERATION



CAUTION

To avoid personal injury:

- Keep engine speed at low idle during the test operation.
- Escaping hydraulic fluid under pressure can have sufficient force to penetrate skin, causing serious personal injury. Before disconnecting lines, be sure to relieve all pressure. Before applying pressure to system, be sure all connections are tight and that lines, tubes and hoses are not damaged. Fluid escaping from a very small hole can be almost invisible. Use a piece of cardboard or wood, rather than hands to search for suspected leaks. If injured by escaping fluid, see a doctor at once. Serious infection or allergic reaction will develop if proper medical treatment is not administered immediately.

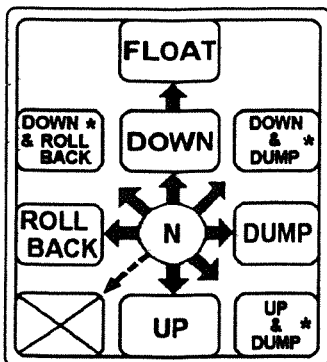

NOTE:

- When the lever is at each corner position marked by asterisk (*), boom and bucket cylinders work at the same time. However, the position marked by cross is not recommended for scooping because of insufficient lift force.

To begin test operation, slightly move the control lever from the "N" position. Slowly raise the loader boom just enough for the bucket to clear the ground when fully dumped. Slowly work through the dump and roll back cycles.

IMPORTANT:

- If the boom or bucket does not work in the directions indicated on the label, lower the bucket to the ground, stop the engine, and relieve all hydraulic pressure. Recheck and correct all hydraulic connections.

4 Position bucket control valve type

This control valve has a two-stage dump position. The first dump position (by moving the lever to the right) is the "Regular" dump position. It has good power and control for precise dumping. This position should be used when operating another implement with the loader's control valve. The second dump position (to further right) features greater speed for dumping. These two positions are separated by a "Feel" position for your convenience.

REMOVING AIR FROM HYDRAULIC SYSTEM

Repeat raising and lowering the boom and bucket operations until all the air is removed from the system and the system responds properly.

IMPORTANT:

- Do not move the control lever into float position when the bucket is off the ground.

OPERATING THE LOADER

The loader should be operated with the tractor engine speed depending on the application and the operator's level of experience. Excessive speeds are dangerous, and may cause bucket spillage and unnecessary strain on the tractor and loader.

When operating in temperatures below -1°C (30°F), run the tractor engine below 1200 min^{-1} (rpm) until the oil temperature exceeds -1°C (30°F).

The following text and illustrations offer suggested loader and tractor operating techniques.

IMPORTANT:

- When operating the loader in rough terrain, remove the mower to avoid damage to the mower.

FILLING THE BUCKET

Approach and enter the pile with a level bucket.

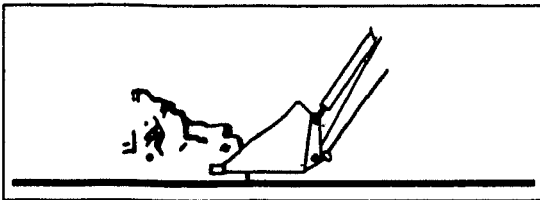

Ease control lever toward you and then roll back to lift the bucket.

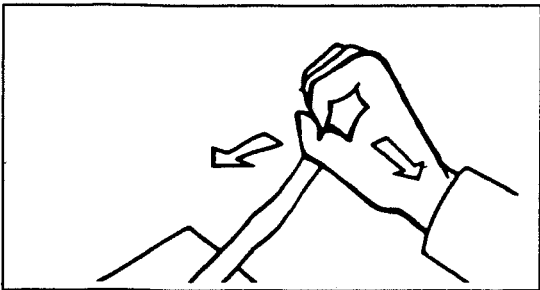

The rollback and lifting of the bucket will increase efficiency because a level bucket throughout the lifting cycle resists bucket lift and increases breakaway effort.

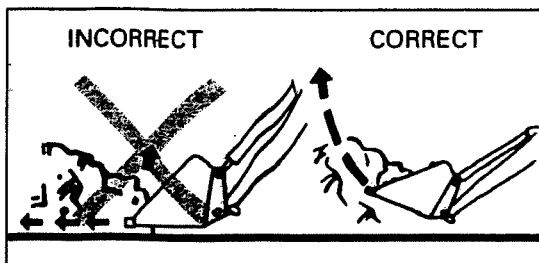

NOTE:

- Do not be concerned if the bucket is not completely filled during each pass. Maximum productivity is determined by the amount of material loaded in a given period of time. Time is lost if two or more attempts are made to fill the bucket on each pass.

LIFTING THE LOAD

When lifting the load, keep the bucket positioned to avoid spillage.

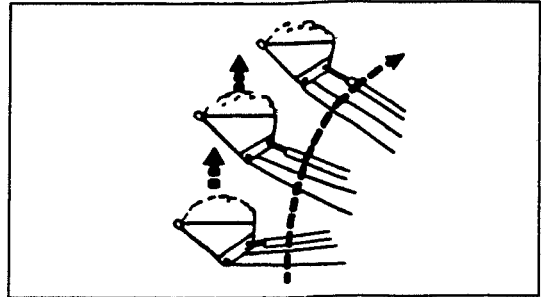

WARNING

To avoid serious personal injury:

- Do not attempt to lift bucket loads in excess of the loader capacity.
- Before raising the bucket to full height, make sure the tractor is on level ground. If not, it may tip over, even if the tractor is not moving.

CARRYING THE LOAD

Position the bucket just below the level of the tractor hood for maximum stability and visibility, whether the bucket is loaded or empty.

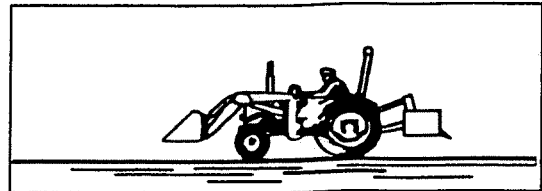

Use extreme care when operating the loader on a slope. Keep the bucket as low as possible. This keeps the bucket and tractor center of gravity low and will provide maximum tractor stability.



WARNING

To avoid serious personal injury:

- Be extra careful when working on inclines.
- When operating on a slope, always operate up and down the slope, never across the slope.

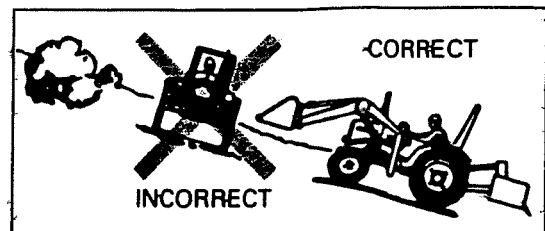

When transporting a load, keep the bucket as low as possible to avoid tipping, in case a wheel drops in a rut.

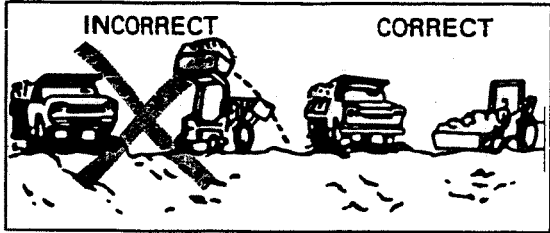

DUMPING THE BUCKET

Lift the bucket just high enough to clear the side of the vehicle. Move the tractor in as close to the side of the vehicle as possible, then dump the bucket.

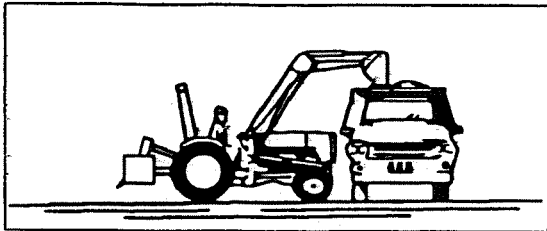

LOWERING THE BUCKET

After the bucket is dumped, back away from the vehicle while lowering and rolling back the bucket.

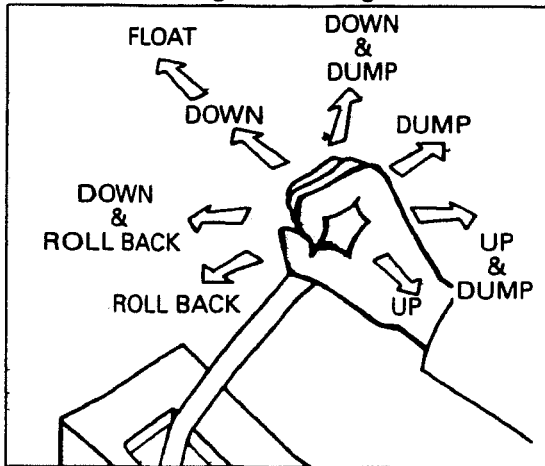

OPERATING WITH FLOAT CONTROL

During operation on hard surface, keep the bucket level and put the lift control in the float position to permit the bucket to float on the working surface. If hydraulic down pressure is exerted on the bucket it will wear faster than normal.

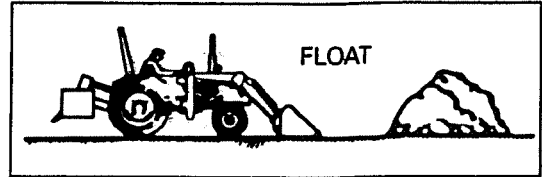

The float position will also avoid mixing of surface material with stockpile material. The float position will reduce the chance of surface gouging while removing snow or other material, or when working with a blade.

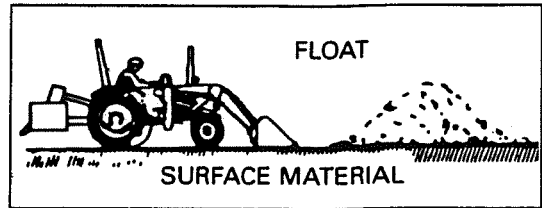

LOADING FROM A BANK

Choose a forward gear that provides a safe ground speed and power for loading.

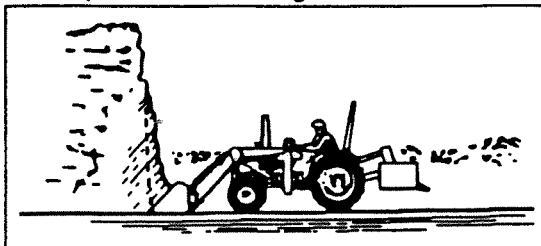

WARNING

To avoid the possibility of serious personal injury:

- Exercise caution when undercutting high banks.
- Dirt slides can be dangerous. Load from as low as possible for maximum efficiency.

NOTE:

- Loader lift and break-away capacity diminish as loading height is increased.

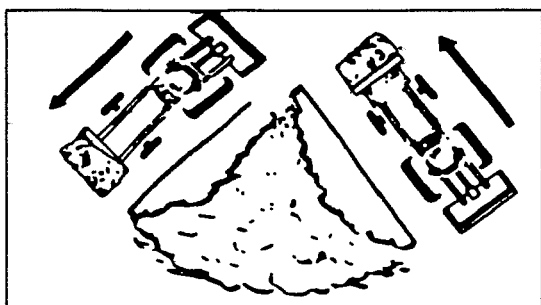

Side cutting is a good technique for cutting down a big pile. Wheel width should not exceed the bucket width for this procedure.

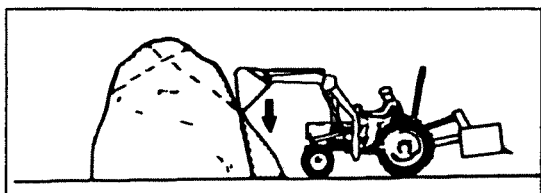

If the pile sides are too high and liable to cause cave-in, use the loader to break down the sides until a slot can be cut over the top.

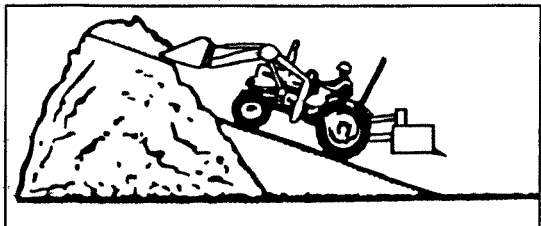

Another method for large dirt piles is to build a ramp to approach to the pile.

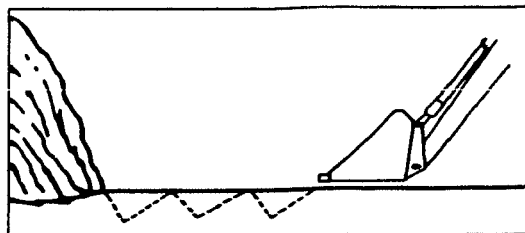

It is important to keep the bucket level when approaching a bank or pile. This will help avoid gouging the work area.

PEELING AND SCRAPING

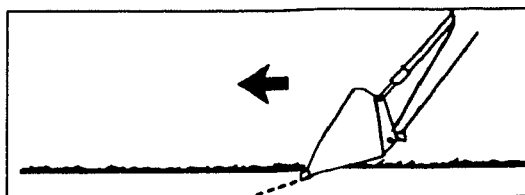

Use a slight bucket down angle, travel forward, and hold the lift control forward to start the cut. Make a short cut and break-out cleanly.

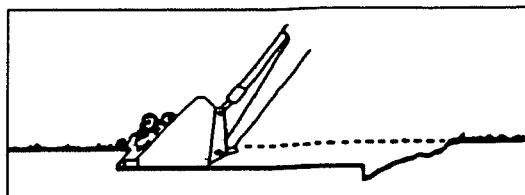

With the bucket level, start a cut at the notch approximately 2 in. deep. Hold the depth by feathering the bucket control to adjust the cutting edge up or down. When the front tires enter the notch, adjust the boom cylinder to maintain proper depth.

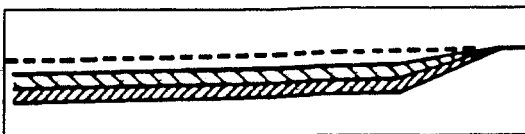

Make additional passes until the desired depth is reached. During each pass, use only the bucket control while at working depth. This will allow you to concentrate on controlling the bucket angle to maintain a precise cut.

LOADING LOW TRUCKS OR SPREADERS FROM A PILE

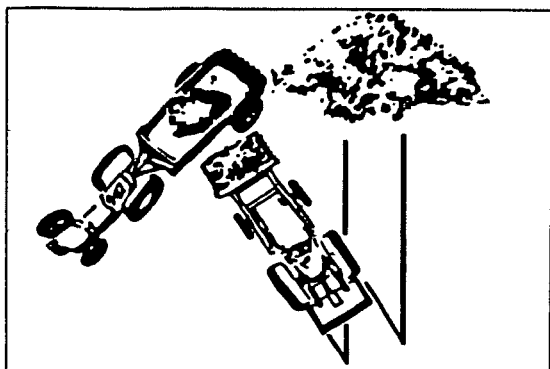

For faster loading, minimize the angle of turn and length of run between pile and spreader.

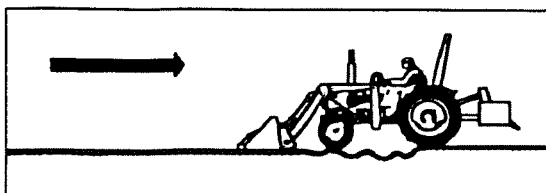

Backgrade occasionally with a loaded bucket to keep the work surface free of ruts and holes. Also, hold the lift control forward so the full weight of the bucket is scraping the ground. Use the heel of the bucket.

BACKFILLING

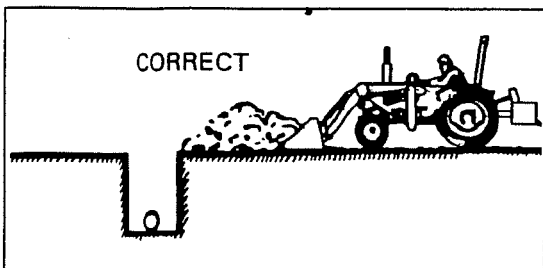

Approach the pile with the bucket flat.

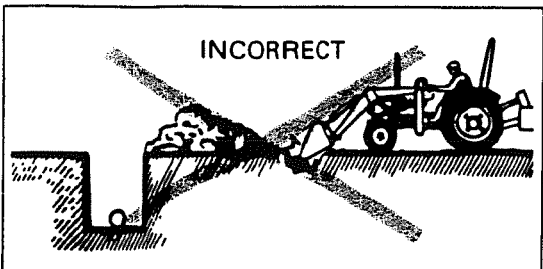

Poor operating methods will move less dirt and make it more difficult to hold a level grade.

IMPORTANT:

- Do not use the bucket in the dumped position for bulldozing. As shown above, this method will impose severe shock loads on the dump-linkage, the bucket cylinders, and the tractor.

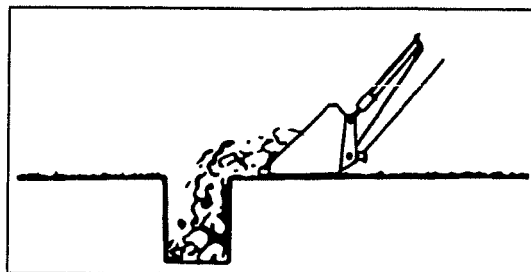

Leave dirt in the bucket because dumping on each pass wastes time.

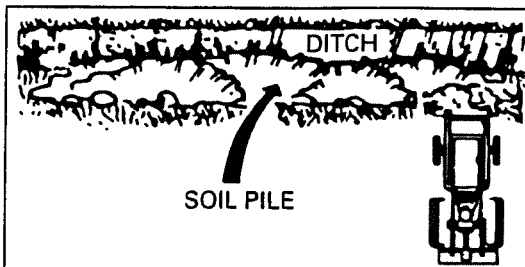

Operate at right angles to the ditch. Taking as big a bite as the tractor can handle.

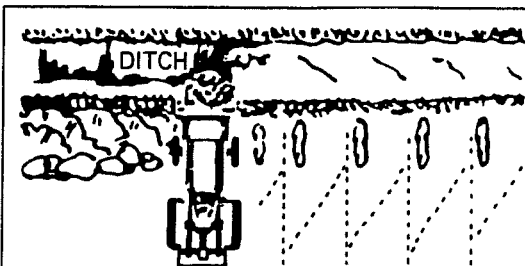

Leave dirt which drifts over the side of the bucket for final cleanup.

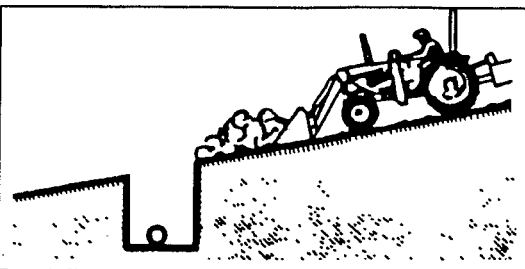

Pile dirt on the high side for easier backfilling on a slope.

HANDLING LARGE HEAVY OBJECTS



WARNING

To avoid serious personal injury:

- Handling large, heavy objects can be dangerous due to :
 - (A) Danger of rolling the tractor over.
 - (B) Danger of upending the tractor.
 - (C) Danger of the object rolling or sliding down the loader boom onto the operator.
- If you must perform the above work, protect yourself by :
 - (A) Not lifting the load higher than necessary to clear the ground when moving.
 - (B) Adding rear ballast to the tractor to compensate for the load.
 - (C) Not lifting large objects with equipment that does not have an anti-rollback device.
 - (D) Moving slowly and carefully.
 - (E) Avoiding rough terrain.
 - (F) Keeping transport distance as short as possible.

MAINTENANCE

LUBRICATION



CAUTION

To avoid personal injury:

- Be sure to check and service the tractor on a flat place with the bucket on the ground, engine shut off, the key removed and the parking brake on.

1. Lubricate all 12 grease fittings every 10 hours of operation. Also, lubricate joints of control lever linkage every 10 hours. High quality grease designating "extreme pressure" and containing Molybdenum disulfide is recommended. This grease may specify "Moly EP" on its label.

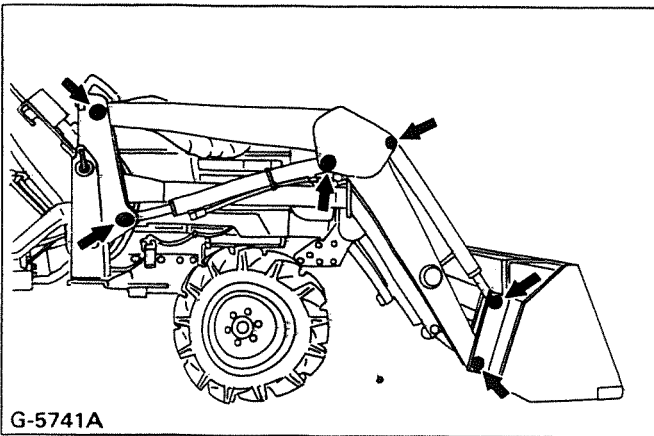

2. Daily before operation, check the tractor hydraulic fluid level. If low, add as described in the tractor's Operator's Manual. Also change the filter element and the hydraulic fluid as recommended in the tractor's Operator's Manual.

DAILY CHECKS

1. Check all hardware daily before operation. Tighten hardware to torque values as specified in the "Installation Instructions" and "Tightening Torque Chart".
2. With the engine off and the bucket on the ground, inspect all hoses for cuts or wear. Check for signs of leaks and make sure all fittings are tight.



CAUTION

To avoid personal injury:

- Escaping hydraulic fluid under pressure can have sufficient force to penetrate skin, causing serious personal injury. Before disconnecting lines, be sure to relieve all pressure. Before applying pressure to system, be sure all connections are tight and that lines, tubes, and hoses are not damaged. Fluid escaping from a very small hole can be almost invisible. Use a piece of cardboard or wood, rather than hands, to search for suspected leaks.

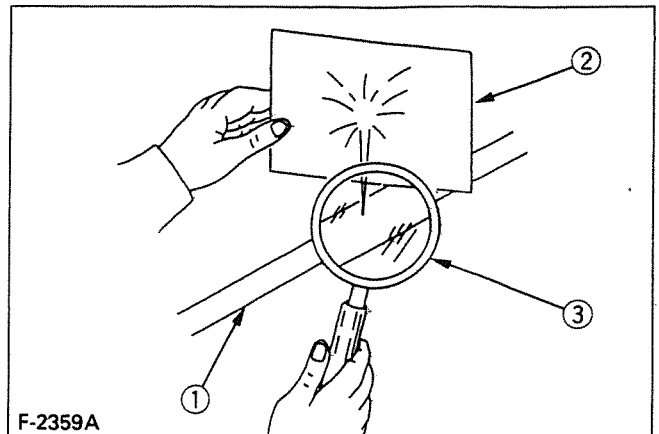



- (1) Hydraulic line
- (2) Cardboard
- (3) Magnifying glass

If injured by escaping fluid, see a doctor at once. Serious infection or allergic reaction will develop if proper medical treatment is not administered immediately.

- When removing the engine side covers, be careful not to touch hot loader cylinders. Allow all surfaces to cool before performing maintenance.

General torque specification

American standard cap screws with UNC or UNF threads 			Metric cap screws 		
SAE grade No.		GR 5 or GR 8	property class		8.8 Approx. SAE GR 5
1/4	(N-m) (kgf-m) (ft-lbs)	9.8 to 11.7 1.0 to 1.2 7.2 to 8.6	M6	(N-m) (kgf-m) (ft-lbs)	9.8 to 11.2 1.0 to 1.1 7.2 to 8.3
5/16	(N-m) (kgf-m) (ft-lbs)	19 to 23.1 1.9 to 2.4 14 to 17	M8	(N-m) (kgf-m) (ft-lbs)	23.6 to 27.4 2.4 to 2.8 17.4 to 20.2
3/8	(N-m) (kgf-m) (ft-lbs)	33.9 to 40.7 3.5 to 4.2 25 to 30	M10	(N-m) (kgf-m) (ft-lbs)	48.1 to 55.8 4.9 to 5.7 35.5 to 41.2
1/2	(N-m) (kgf-m) (ft-lbs)	88.1 to 105.8 9.0 to 10.8 65 to 78	M12	(N-m) (kgf-m) (ft-lbs)	77.5 to 90.1 7.9 to 9.2 57.2 to 66.5
9/16	(N-m) (kgf-m) (ft-lbs)	122 to 146.4 12.4 to 14.9 90 to 108	M14	(N-m) (kgf-m) (ft-lbs)	124 to 147 12.6 to 15.0 91.2 to 108
5/8	(N-m) (kgf-m) (ft-lbs)	176.3 to 211.5 18.0 to 21.6 130 to 156	M16	(N-m) (kgf-m) (ft-lbs)	196 to 225 20.0 to 23.0 145 to 166

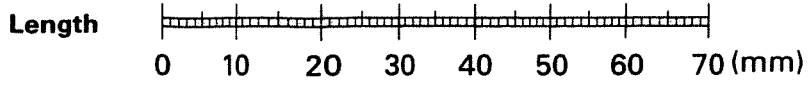
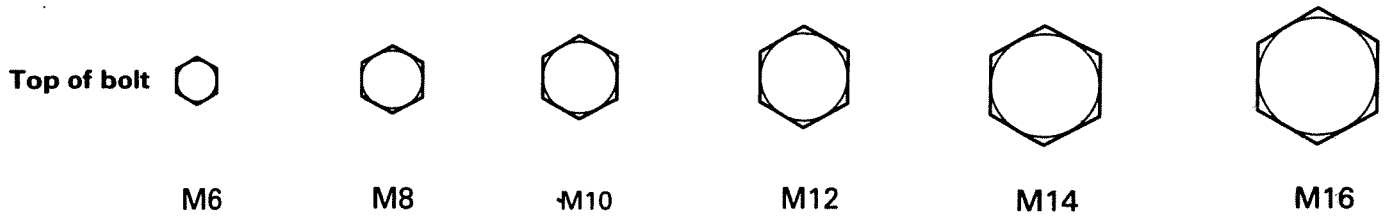

REMOVING THE LOADER



CAUTION

To avoid personal injury:

- For removing the loader, choose flat and hard ground, preferably concrete. When starting the engine or using the hydraulic control valve, always sit in the operator's seat.

If the ground surface is soft, place suitable planks on the ground for the bucket and stands. Make sure bucket and stands are at ground level.

1. Raise the boom until the stands can be rotated.
2. Stop the engine.
3. Remove the spring pins holding the stands to the boom.
4. Slide the stands outward and rotate them until the hole in the stand and pin on the boom are aligned. Then slide the stands inward and insert the spring pin as shown.

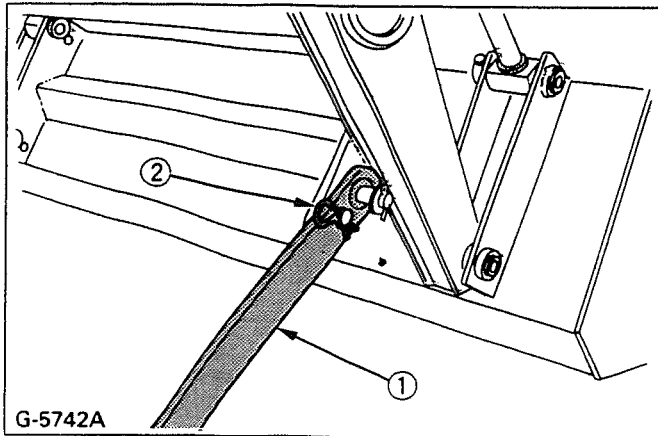

G-5742A

- (1) Stand
(2) Spring pin

5. Start the engine.
6. Dump the bucket approximately 20 degrees.
7. Lower the boom and raise the front wheels slightly.

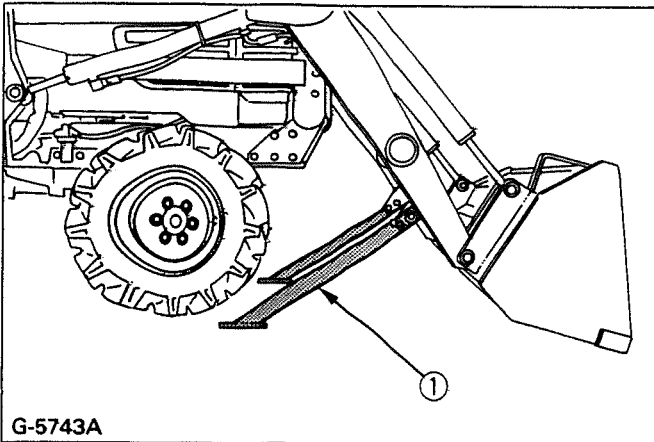

G-5743A

- (1) Stand

IMPORTANT:

- Lift the front wheels with the bucket. Do not attempt to lift them with the stands.

8. Stop the engine.
9. Remove the mounting pins from the loader main frame and hold them on the side frames with spring pins.
10. Start the engine and run at idle. Slowly move the hydraulic control lever to rollback position to raise the loader side frames up and out of the receivers of the main frames as shown.

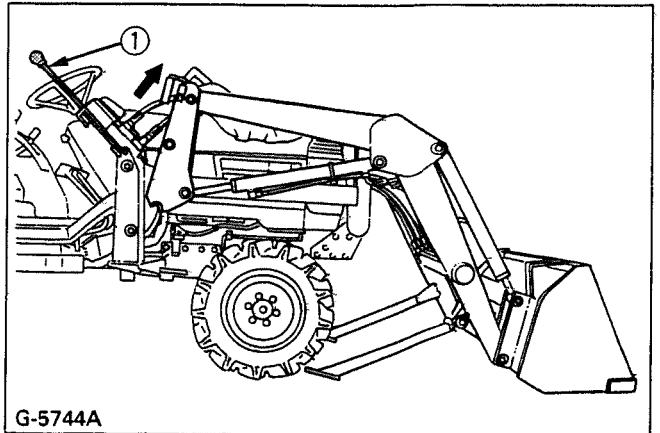

G-5744A

- (1) Hydraulic control lever

11. Stop the engine.
12. Slowly release all hydraulic pressure by moving the hydraulic control lever in all directions.
13. Disconnect the four hoses with quick couplers at the control valve and place them on the right side of the boom.
14. Place the protective caps and plugs on the quick coupler ends.

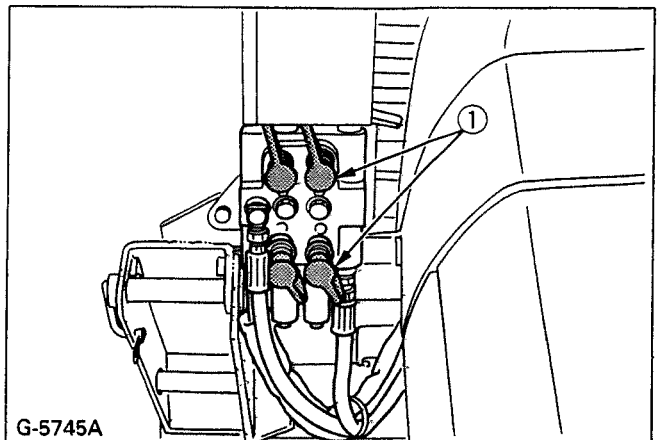

G-5745A

- (1) Protective caps

15. Start the engine and slowly back the tractor away from the loader.

STORING THE LOADER

1. Store the loader in a clean dry place.
2. Make sure the loader is properly supported.
3. Attach the protective plugs and caps to the couplers to protect from dust.

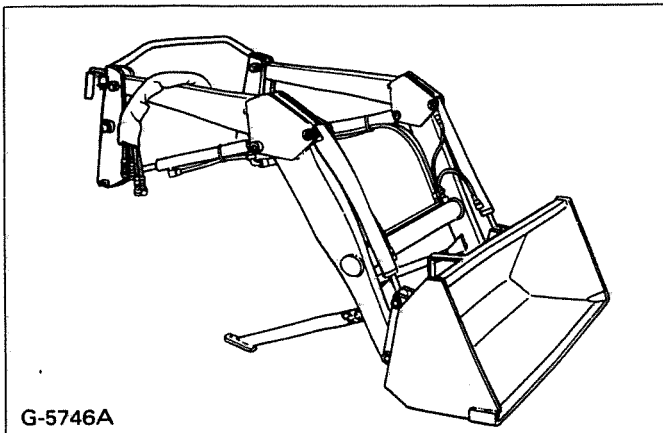

4. Check hydraulic hoses and connections. Repair or replace if necessary.
5. Repair or replace any worn, damaged or missing parts.
6. Lubricate loader as described "LUBRICATION" in Maintenance section.
7. Apply a coat of grease to all exposed cylinder rods and mounting pins to prevent rust.
8. Repaint worn or scratched parts.

REINSTALLING THE LOADER



CAUTION

To avoid personal injury:

- When starting the engine and operating the control valve, always sit in the operator's seat.

1. Slowly drive the tractor between the loader side frames until the rear portion of the side frames touches the main frame.

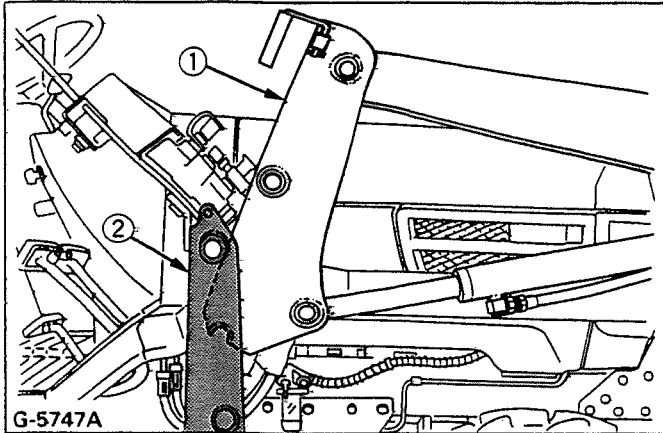

- (1) Side frame
(2) Main frame

2. Stop the engine.
3. Connect four hoses with couplers to the nipples on the control valve as indicated with color marks. Then connect protective caps and plugs together.

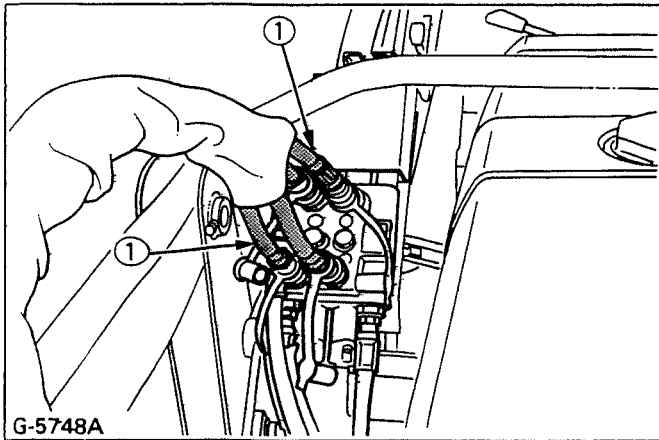

- (1) Hose 1 and Hose 2

4. Start the engine and run at idle.
5. Slowly move the hydraulic control lever to dump position to lower the side frames into the main frame and engage the bosses of the side frames to the guide plates of the main frame. Then lift the front wheels slightly with the loader.

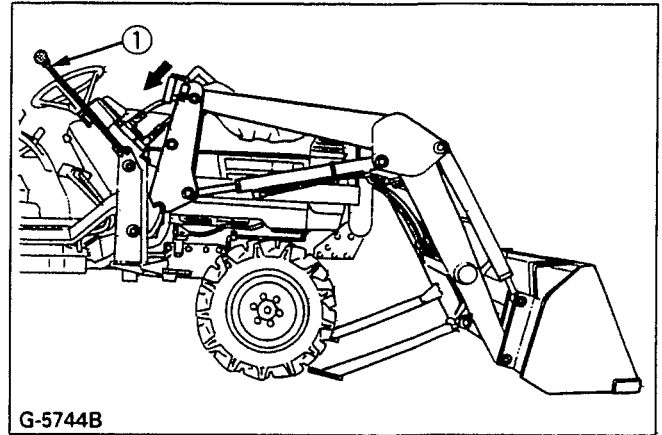

- (1) Hydraulic control lever

IMPORTANT:

- Do not attempt to lift the front wheels with the stands.
6. Stop the engine. Reinstall the mounting pins and secure them with the spring pins.
 7. Start the engine.
 8. Raise the boom until the stands can be rotated.
 9. Stop the engine.
 10. Store the stands to their original positions and secure them with the spring pins as shown.

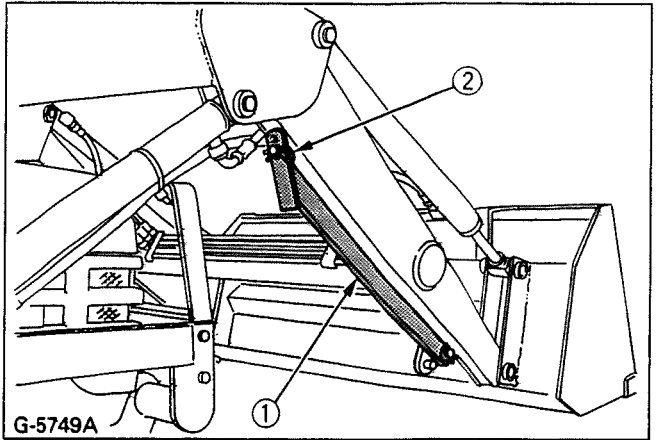

- (1) Stand
(2) Spring pin

11. Start the engine.
12. Lower the boom and level the bucket.

KUBOTA Corporation is . . .

Since its inception in 1890, KUBOTA Corporation has grown to rank as one of the major firms in Japan.

To achieve this status, the company has through the years diversified the range of its products and services to a remarkable extent. Nineteen plants and 16,000 employees produce over 1,000 different items, large and small.

All these products and all the services which accompany them, however, are unified by one central commitment. KUBOTA makes products which, taken on a national scale, are basic necessities. Products which are indispensable. Products which are intended to help individuals and nations fulfill the potential inherent in their environment. KUBOTA is the Basic Necessities Giant.

This potential includes water supply, food from the soil and from the sea, industrial development, architecture and construction, and transportation.

Thousands of people depend on KUBOTA's know-how, technology, experience and customer service. You too can depend on KUBOTA.

Kubota

- U.S.A. : **KUBOTA TRACTOR CORPORATION**
3401 Del Amo Blvd., Torrance, CA 90503, U.S.A.
Telephone : (310)370-3370
- Western Division : 6665 E. Hardaway Rd., Stockton, CA 95215
Telephone : (209)931-5051
- Central Division : 14855 FAA Blvd., Fort Worth, TX 76155
Telephone : (817)571-0900
- Northern Division : 2626 Port Road, Columbus, OH 43217
Telephone : (614)492-1100
- Southeast Division : 1025 Northbrook Parkway, Suwanee, GA 30024
Telephone : (770)995-8855
- Canada : **KUBOTA CANADA LTD.**
5900 14th Avenue, Markham, Ontario, L3S 4K4, Canada
Telephone : (905)294-7477
- Delta Distribution Center : 7979 82nd St, Delta B.C. V4G 1L7
Telephone : (604)940-6061
- Drummondville Distribution Center : 5705 Place Kubota, Drummondville, Québec, J2B 6B4
Telephone : (819)478-7151
- France : **KUBOTA EUROPE S.A.**
19-25, Rue Jules Vercey, Z.I. BP88, 95101 Argenteuil Cedex, France
Telephone : (33)1-3426-3434
- Germany : **KUBOTA (DEUTSCHLAND) GmbH**
Senefelder Str. 3-5 63110 Rodgau /Nieder-Roden, Germany
Telephone : (49)6106-873-0
- U.K. : **KUBOTA (U.K.) LTD.**
Dormer Road, Thame, Oxfordshire, OX9 3UN, U.K.
Telephone : (44)1844-214500
- Australia : **KUBOTA TRACTOR AUSTRALIA PTY LTD.**
100 Keilor Park Drive, Tullamarine, Victoria 3043 Australia
Telephone : (61)-3-9279-2000
- Malaysia : **SIME KUBOTA SDN. BHD.**
Lot pt 11101 Kompleks Sime Darby, Jalan Kewajipan,
Subang Jaya, 47600 Petaling Jaya, Selangor Darul Ehsan, West Malaysia
Telephone : (60)3-736-1388
- Philippines : **KUBOTA AGRO-INDUSTRIAL MACHINERY PHILIPPINES, INC.**
155 Panay Avenue, South Triangle Homes, 1103 Quezon City, Philippines
Telephone : (63)2-9201071
- Taiwan : **SHIN TAIWAN AGRICULTURAL MACHINERY CO., LTD.**
16, Fengping 2nd Rd, Taliiao Shiang Kaohsiung 83107, Taiwan R.O.C.
Telephone : (886)7-702-2333
- Brazil : **KUBOTA BRASIL LTDA.**
Rua Dona Maria Fidelis No.171, Diadema, São Paulo, Brazil
Telephone : (55)11-745-4744
- Indonesia : **P.T. KUBOTA INDONESIA**
JALAN. Setyabudi 279, Semarang, Indonesia
Telephone : (62)-24-472849
- Thailand : **THE SIAM KUBOTA INDUSTRY CO., LTD.**
101/19-24 Navanakorn, Tambol Klongneung, Amphur Klongluang, Pathumtani 12120, Thailand
Telephone : (66)2-529-0363
- Egypt : **KUBOTA Corporation CAIRO LIAISON OFFICE**
12th Floor, Nile Tower Bldg.
21-23 Guiza Street, Guiza, Egypt
Telephone : (20)2-5702390
- Japan : **KUBOTA Corporation**
Farm & Industrial Machinery International Operations Headquarters
2-47, Shikitsuhigashi 1-chome, Naniwa-ku, Osaka, Japan 556-8601
- KUBOTA MANUFACTURING OF AMERICA CORPORATION**
2715 Ramsey Road, Gainesville, GA, 30501 U.S.A.
Telephone : (770)532-0038

英語(U.S.A)
Code No. 7J043-6911-2

L
A
2
7
2
·
L
A
3
0
2
·
L
A
3
5
2
·
L
A
4
0
·