

WSM

WORKSHOP MANUAL
TRACTOR

BX1800, BX2200

Kubota

TO THE READER

This Workshop Manual has been prepared to provide servicing personnel with information on the mechanism, service and maintenance of KUBOTA Tractors BX1800 and BX2200. It is divided into two parts, "Mechanism" and "Servicing" for each section.

■ Mechanism

Information on the construction and function are included. This part should be understood before proceeding with troubleshooting, disassembling and servicing.

■ Servicing

Under the heading "General" section comes general precautions, check and maintenance and special tools. Other section, there are troubleshooting, servicing specification lists, checking and adjusting, disassembling and assembling, and servicing which cover procedures, precautions, factory specifications and allowable limits.

All information illustrations and specifications contained in this manual are based on the latest product information available at the time of publication.

The right is reserved to make changes in all information at any time without notice.

January 2000

© KUBOTA Corporation 2000

SAFETY FIRST

This symbol, the industry’s “Safety Alert Symbol”, is used throughout this manual and on labels on the machine itself to warn of the possibility of personal injury. Read these instructions carefully.

It is essential that you read the instructions and safety regulations before you attempt to repair or use this unit.



DANGER : Indicates an imminently hazardous situation which, if not avoided, will result in death or serious injury.

WARNING : Indicates a potentially hazardous situation which, if not avoided, could result in death or serious injury.

CAUTION : Indicates a potentially hazardous situation which, if not avoided, may result in minor or moderate injury.

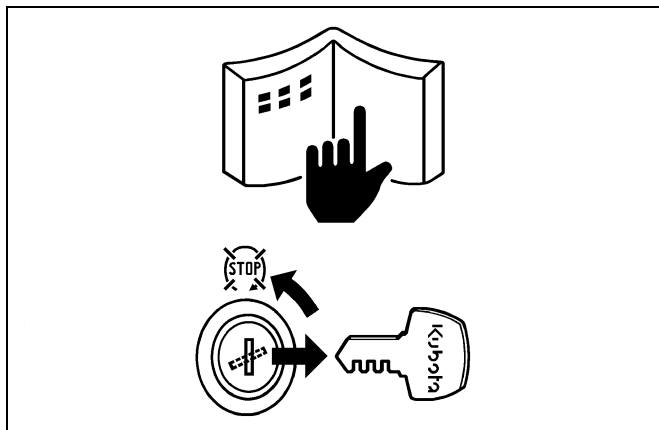

IMPORTANT : Indicates that equipment or property damage could result if instructions are not followed.

NOTE : Gives helpful information.

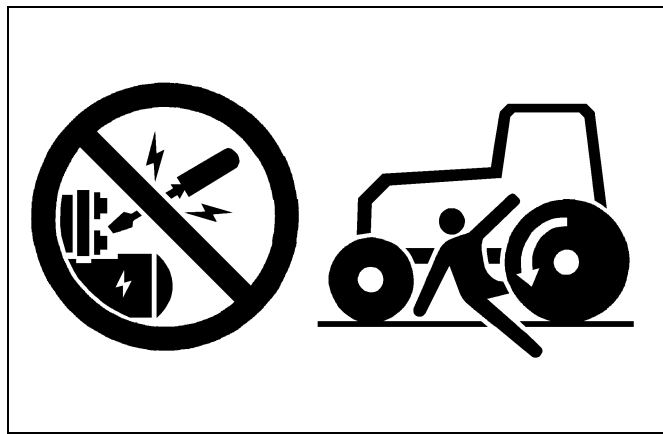

BEFORE SERVICING AND REPAIRING

- Read all instructions and safety instructions in this manual and on your machine safety decals.
- Clean the work area and machine.
- Park the machine on a firm and level ground, and set the parking brake.
- Lower the implement to the ground.
- Stop the engine, and remove the key.
- Disconnect the battery negative cable.
- Hang a “**DO NOT OPERATE**” tag in operator station.



SAFETY STARTING

- Do not start the engine by shorting across starter terminals or bypassing the safety start switch.
- Do not alter or remove any part of machine safety system.
- Before starting the engine, make sure that all shift levers are in neutral positions or in disengaged positions.
- Never start the engine while standing on ground. Start the engine only from operator's seat.

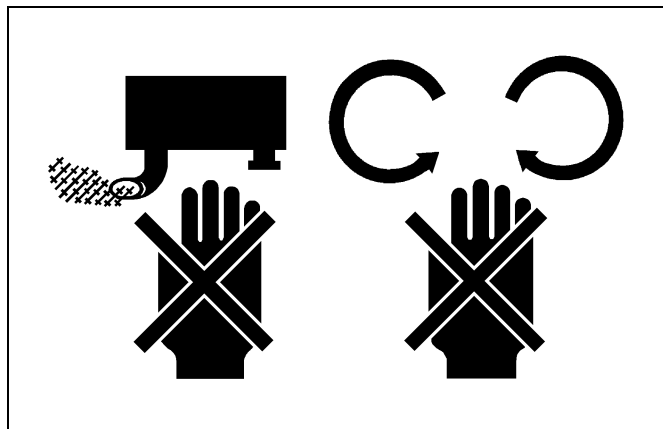

SAFETY WORKING

- Do not work on the machine while under the influence of alcohol, medication, or other substances or while fatigued.
- Wear close fitting clothing and safety equipment appropriate to the job.
- Use tools appropriate to the work. Makeshift tools, parts, and procedures are not recommended.
- When servicing is performed together by two or more persons, take care to perform all work safely.
- Do not work under the machine that is supported solely by a jack. Always support the machine by safety stands.
- Do not touch the rotating or hot parts while the engine is running.
- Never remove the radiator cap while the engine is running, or immediately after stopping. Otherwise, hot water will spout out from radiator. Only remove radiator cap when cool enough to touch with bare hands. Slowly loosen the cap to first stop to relieve pressure before removing completely.
- Escaping fluid (fuel or hydraulic oil) under pressure can penetrate the skin causing serious injury. Relieve pressure before disconnecting hydraulic or fuel lines. Tighten all connections before applying pressure.

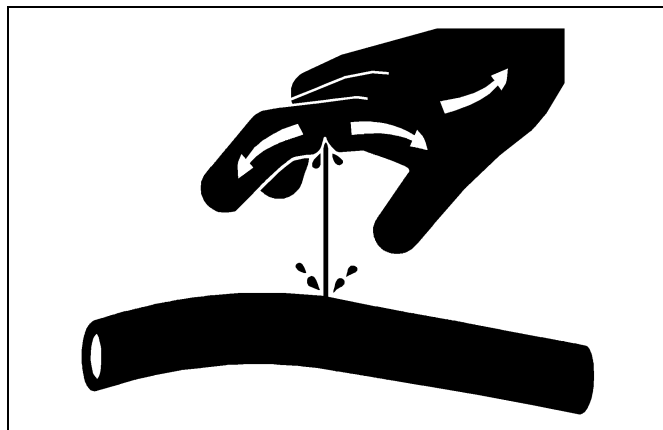

AVOID FIRES

- Fuel is extremely flammable and explosive under certain conditions. Do not smoke or allow flames or sparks in your working area.
- To avoid sparks from an accidental short circuit, always disconnect the battery negative cable first and connect it last.
- Battery gas can explode. Keep sparks and open flame away from the top of battery, especially when charging the battery.
- Make sure that no fuel has been spilled on the engine.

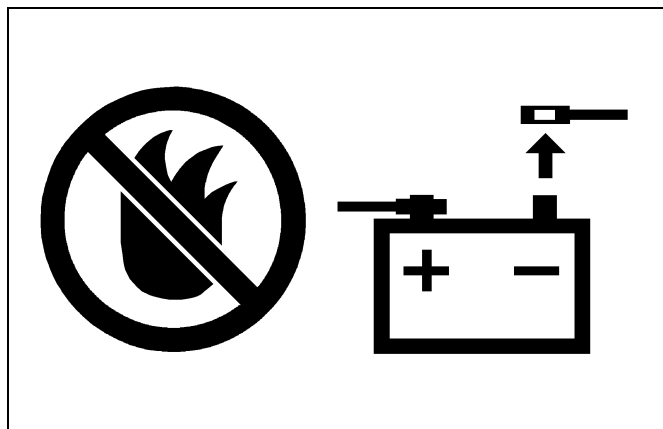

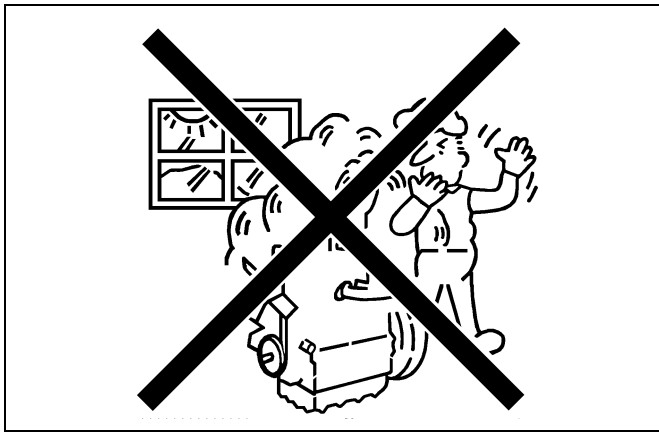

VENTILATE WORK AREA

- If the engine must be running to do some work, make sure the area is well ventilated. Never run the engine in a closed area. The exhaust gas contains poisonous carbon monoxide.

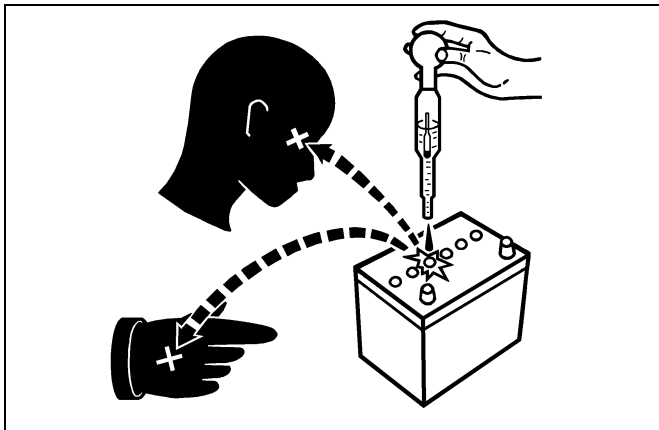

PREVENT ACID BURNS

- Sulfuric acid in battery electrolyte is poisonous. It is strong enough to burn skin, clothing and cause blindness if splashed into eyes. Keep electrolyte away from eyes, hands and clothing. If you spill electrolyte on yourself, flush with water, and get medical attention immediately.

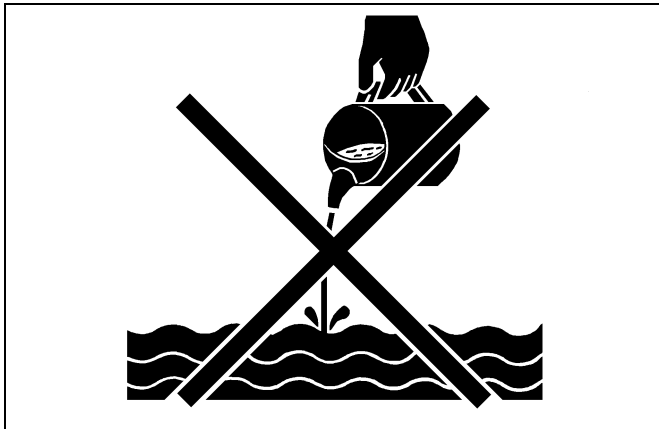

DISPOSE OF FLUIDS PROPERLY

- Do not pour fluids into the ground, down a drain, or into a stream, pond, or lake. Observe relevant environmental protection regulations when disposing of oil, fuel, coolant, electrolyte and other harmful waste.

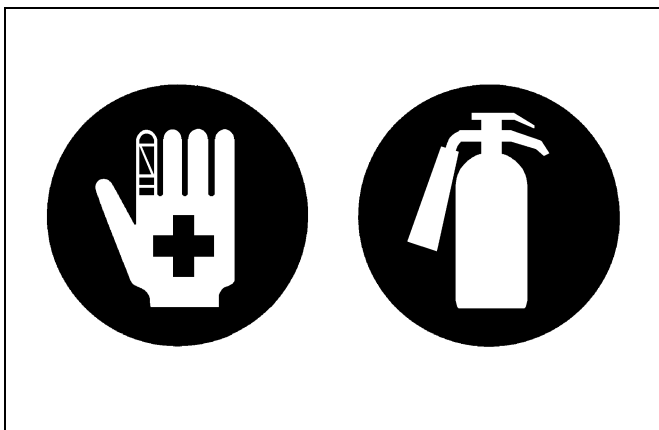

PREPARE FOR EMERGENCIES

- Keep a first aid kit and fire extinguisher handy at all times.
- Keep emergency numbers for doctors, ambulance service, hospital and fire department near your telephone.

SAFETY DECALS

The following safety decals are installed on the machine.

If a decal becomes damaged, illegible or is not on the machine, replace it. The decal part number is listed in the parts list.

(1) Part No. K2561-6554-1



⚠ WARNING

TO AVOID PERSONAL INJURY:

- 1 Keep PTO shield in place at all times.
- 2 Do not operate the PTO at speeds faster than the speed recommended by the implement manufacturer.
- 3 For trailing PTO-driven implements, set hitch at towing position. (see operator's manual)

(2) Part No. K2561-6557-1

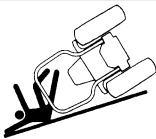

⚠ WARNING

TO AVOID PERSONAL INJURY OR DEATH FROM ROLL-OVER:

1. Kubota recommends the use of a Roll-Over Protective Structures (ROPS) and seat belt in almost all applications.
2. Remove the ROPS only when it substantially interferes with operation or itself presents a safety risk. (Examples include work in orchards and vineyards) **ALWAYS REINSTALL IT BEFORE USING THE TRACTOR IN OTHER APPLICATIONS.**
3. Never use just the seat belt or just the ROPS. They must be used together. For further details consult your Operator's Manual or your local dealer.

(3) Part No. K2561-6548-1

⚠ CAUTION

TO AVOID PERSONAL INJURY:

1. Read and understand the operator's manual before operation.
2. Before starting the engine, make sure that everyone is at a safe distance from the tractor and that the PTO is OFF.
3. Do not allow passengers on the tractor at any time.
4. Before allowing other people to use the tractor, have them read the operator's manual.
5. Check the tightness of all nuts and bolts regularly.
6. Keep all shields in place and stay away from all moving parts.
7. Slow down for turns, or rough roads.
8. On public roads use SMV emblem and hazard lights, if required by local traffic and safety regulations.
9. Pull only from the hitch.
10. Before dismounting lower the implement, set the parking brake, stop the engine and remove the key.

(4) Part No. K2561-6552-2

Do not put hands under the rear fender.

⚠ WARNING





TO AVOID PERSONAL INJURY: KEEP HANDS AWAY FROM PINCH POINTS OF LIFT ARMS.

K2561-65522

(5) Part No. K2561-6549-1

Diesel fuel only No fire





(6) Part No. K2561-6556-1

⚠ WARNING

TO AVOID PERSONAL INJURY:

1. Attach pulled or towed loads to the hitch only.
2. Use the 3-point hitch only with equipment designed for 3-point hitch usage.

(7) Part No. K2561-6555-1

⚠ CAUTION

TO AVOID PERSONAL INJURY FROM SEPARATION

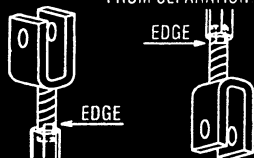

DO NOT EXTEND LIFT ROD BEYOND THE EDGE OF FLAT FACE ON THE THREADED ROD.

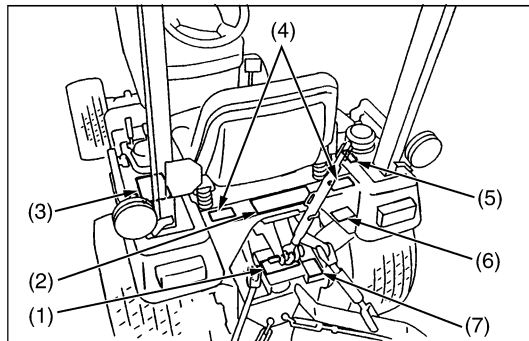

(8) Part No. K2561-6541-1



⚠ DANGER

TO AVOID POSSIBLE INJURY OR DEATH FROM A MACHINE RUNAWAY.

1. Do not start engine by shorting across starter terminals or bypassing the safety start switch. Machine may start in gear and move if normal starting circuitry is bypassed.
2. Start engine only from operator's seat with transmission and PTO OFF. Never start engine while standing on the ground.

(9) Part No. K2561-6543-1
Stay clear of engine fan and fanbelt.



(10) Part No. K2561-6542-1

Do not touch hot surface like muffler, etc.

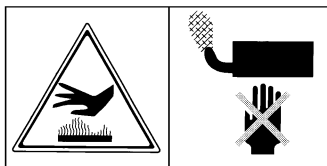

(11) Part No. K2561-6115-1

KEEP OUT OF THE REACH OF CHILDREN.
DO NOT TIP. DO NOT OPEN BATTERY!

FLUSH EYES IMMEDIATELY WITH WATER



GET MEDICAL HELP FAST



(12) Part No. K2561-6116-1

⚠ DANGER/POISON

 SHIELD EYES EXPLOSIVE GASES CAN CAUSE BLINDNESS OR INJURY	 NO • SPARKS • FLAMES • SMOKING	 SULFURIC ACID CAN CAUSE BLINDNESS OR SEVERE BURNS
---	---	--

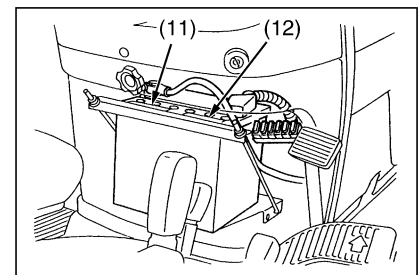
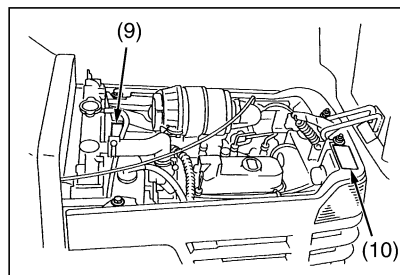
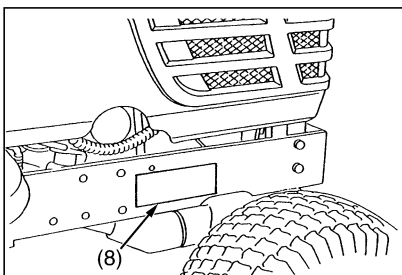

CARE OF DANGER, WARNING AND CAUTION LABELS

1. Keep danger, warning and caution labels clean and free from obstructing material.
2. Clean danger, warning and caution labels with soap and water, dry with a soft cloth.
3. Replace damaged or missing danger, warning and caution labels with new labels.
4. If a component with danger, warning or caution label (s) affixed is replaced with new part, make sure new label (s) is (are) attached in the same location (s) as the replaced component.
5. Mount new danger, warning and caution labels by applying on a clean dry surface and pressing any bubbles to outside edge.

3TAAAABCP002A

SPECIFICATIONS

Model		BX1800	BX2200
PTO power		10.2 kW (13.7 HP)*	12.4 kW (16.7 HP)*
Engine	Maker	KUBOTA	
	Model	D722-E-BX	D905-E-BX
	Type	Indirect Injection. Vertical, water-cooled, 4-cycle diesel	
	Number of cylinders	3	
	Bore and stroke	67 × 68 mm (2.64 × 2.68 in.)	72 × 73.6 mm (2.83 × 2.90 in.)
	Total displacement	719 cm ³ (43.9 cu.in.)	898 cm ³ (54.8 cu.in.)
	Engine gross power (DIN)	13.4 kW (18.0 HP)	16.4 kW (22.0 HP)
	Rated revolution	53.3 r/s [3200 min ⁻¹ (rpm)]	
	Maximum torque	41.5 N·m (4.23 kgf·m, 30.6 ft-lbs) / 36.7 to 43.3 r/s [2200 to 2600 min ⁻¹ (rpm)]	54.9 N·m (5.6 kgf·m, 40.5 ft-lbs) / 36.7 to 43.3 r/s [2200 to 2600 min ⁻¹ (rpm)]
	Battery	12 V, CCA : 435 A, RC : 62 min.	12 V, CCA : 535 A, RC : 80 min.
	Starting system	Electric starting with cell starter, 12 V, 1.4 kW	
	Lubrication system	Forced lubrication by trochoidal pump	
	Cooling system	Pressurized radiator, forced circulation with water pump	
	Fuel	Diesel fuel No. 2-D [above -10 °C (14 °F)], Diesel fuel No. 1 [below -10 °C (14 °F)]	
Capacities	Fuel tank	21 L (5.5 U.S.gals, 4.6 Imp.gals.)	
	Engine crankcase (with filter)	1.9 L (2.01 U.S.qts., 1.67 Imp.qts.)	2.5 L (2.64 U.S.qts., 2.20 Imp.qts.)
	Engine coolant (with recovery tank)	2.9 L (3.06 U.S.qts., 2.55 Imp.qts.)	3.5 L (3.70 U.S.qts., 3.08 Imp.qts.)
	Transmission case	10.1 L (2.7 U.S.gals, 2.2 Imp.gals.)	
	Front axle case	4.7 L (4.97 U.S.qts., 4.14 Imp.qts.)	
Dimensions	Overall length (without 3P)	2025 mm (79.7 in.)	
	Overall width	1145 mm (45.1 in.)	
	Overall height (with ROPS)	1800 mm (70.9 in.)	
	Overall height (top of steering wheel)	1200 mm (47.2 in.)	
	Wheel base	1400 mm (55.1 in.)	
	Minimum ground clearance (bottom of hitch bracket)	170 mm (6.7 in.)	
	Tread	Front	910 mm (35.8 in.)
	Rear	820 mm (32.2 in.)	
Weight		570 kg (1257 lbs)	590 kg (1301 lbs)
Travelling system	Tires	Front	18 × 8.50 – 8 (Turf)
		Rear	26 × 12.00 – 12 (Turf)
	Steering	Hydrostatic power steering	
	Transmission	Main-hydrostatic transmission, Range gear shift (2 forward and 2 reverse)	
	Brake	Wet disc type	
	Min. turning radius (without brake)	2.3 m (7.5 feet)	
	Differential	Bevel gear	
Hydraulic system	Hydraulic control system	Directional control, auto-return lever system	
	Pump capacity	21.0 L/min. (5.5 U.S.gals./min., 4.6 Imp.gals./min.)	
	Three point hitch	SAE Category I	
	Max. lift force (24 in. behind lift points)	3040 N (310 kg, 684 lbs)	
PTO system	Clutch	Wet type, multiple discs	
	Mid	PTO shaft	USA No. 5 (KUBOTA 10-tooth) involute spline
		Revolution	41.7 r/s [2500 min ⁻¹ (rpm)] / engine 52.1 r/s [3125 min ⁻¹ (rpm)]
	Rear	PTO shaft	SAE 1-3/8, 6 splines
Revolution		9.0 r/s [540 min ⁻¹ (rpm)] / engine 51.1 r/s [3068 min ⁻¹ (rpm)]	

NOTE: * Manufacture's estimate
The company reserves the right to change the specifications without notice.

W1028103

TRAVELLING SPEEDS

Model		BX1800, BX2200	
Tire size (Rear)		26 × 12.00 – 12	
	Range gear shift lever	km/h	mile/h
Forward	Low	0 to 5.9	0 to 3.7
	High	0 to 13.0	0 to 8.1
Reverse	Low	0 to 4.5	0 to 2.8
	High	0 to 10.0	0 to 6.2

The company reserves the right to change the specifications without notice.

W1035065

DIMENSIONS

Unit : mm (in.)

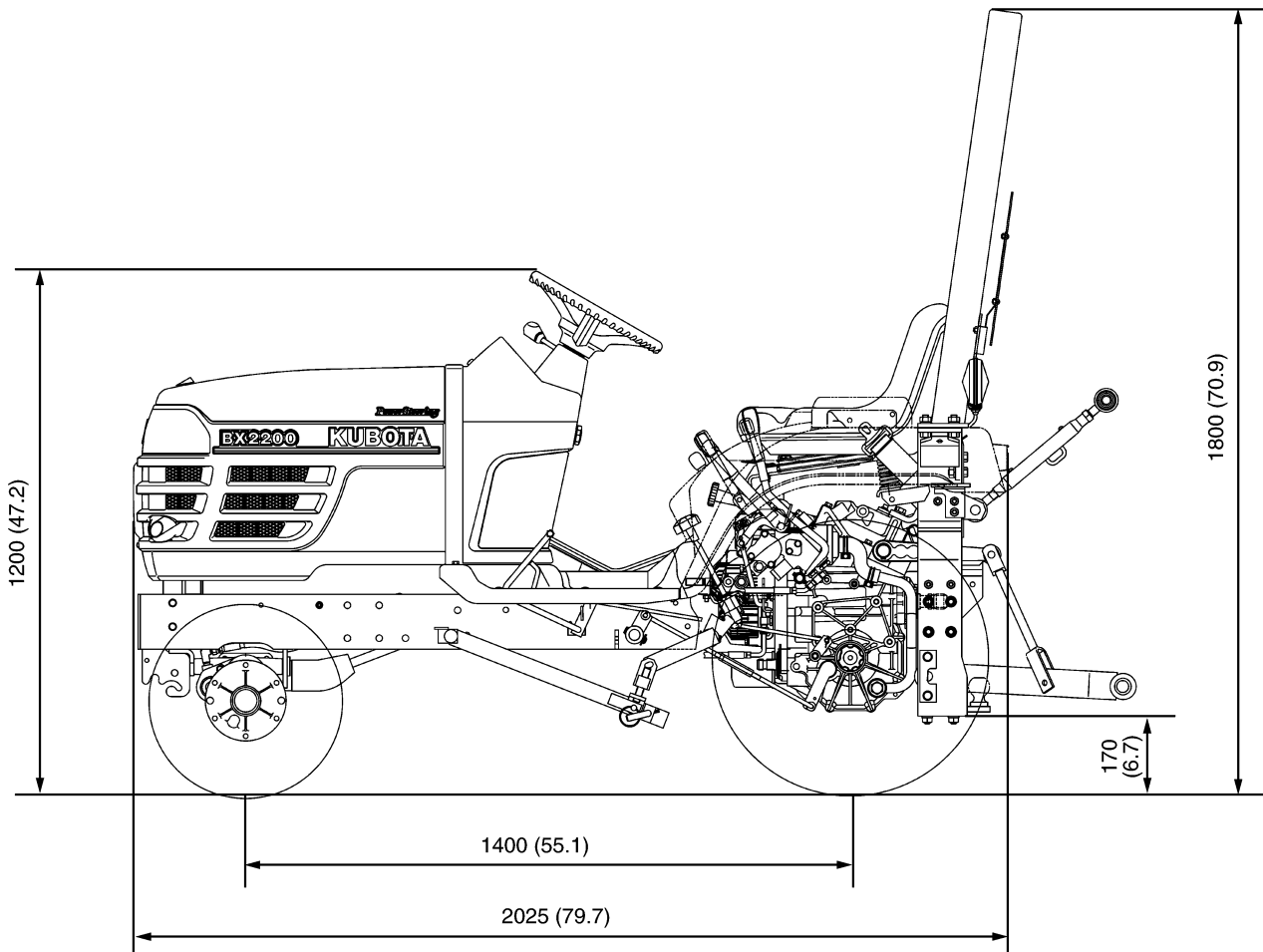
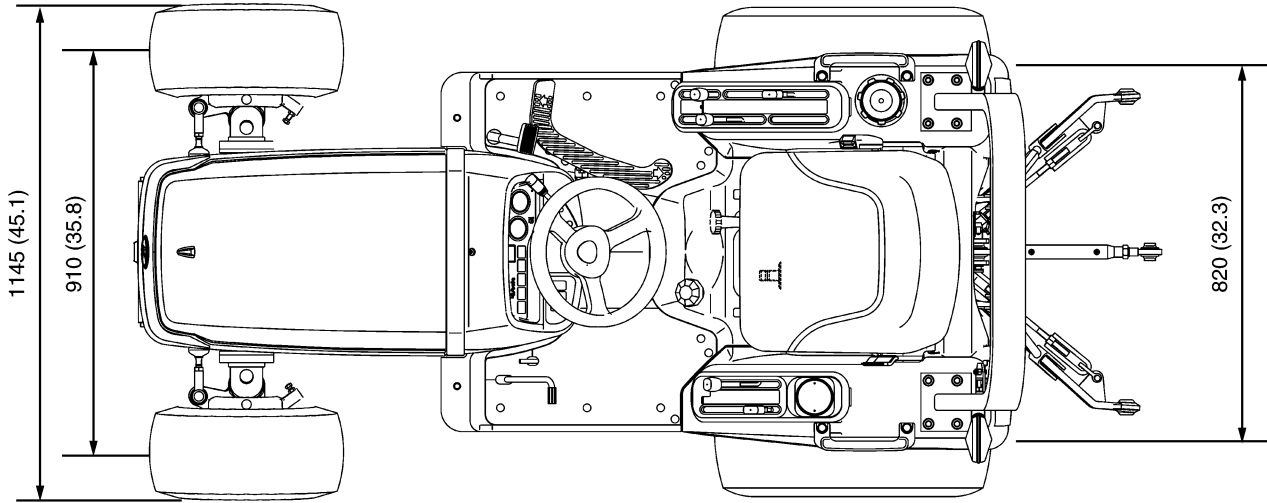

3TAAAABFP001A

G GENERAL

GENERAL

CONTENTS

1. TRACTOR IDENTIFICATION	G-1
2. GENERAL PRECAUTIONS	G-2
3. HANDLING PRECAUTIONS FOR ELECTRICAL PARTS AND WIRING ..	G-3
[1] WIRING	G-3
[2] BATTERY	G-5
[3] FUSE	G-5
[4] CONNECTOR	G-5
[5] HANDLING OF CIRCUIT TESTER	G-6
4. LUBRICANTS, FUEL AND COOLANT	G-7
5. TIGHTENING TORQUES	G-8
[1] GENERAL USE SCREWS, BOLTS AND NUTS	G-8
[2] STUD BOLTS	G-8
[3] AMERICAN STANDARD SCREWS, BOLTS AND NUTS WITH UNC OR UNF THREADS	G-9
6. MAINTENANCE CHECK LIST	G-10
7. CHECK AND MAINTENANCE	G-11
[1] DAILY CHECK	G-11
[2] CHECK POINTS OF INITIAL 50 HOURS	G-12
[3] CHECK POINTS OF EVERY 50 HOURS	G-14
[4] CHECK POINTS OF EVERY 100 HOURS	G-15
[5] CHECK POINTS OF EVERY 200 HOURS	G-20
[6] CHECK POINTS OF EVERY 300 HOURS	G-21
[7] CHECK POINTS OF EVERY 400 HOURS	G-22
[8] CHECK POINTS OF EVERY 500 HOURS	G-23
[9] CHECK POINTS OF EVERY 800 HOURS	G-23
[10] CHECK POINTS OF EVERY 1500 HOURS	G-23
[11] CHECK POINTS OF EVERY 3000 HOURS	G-23
[12] CHECK POINTS OF EVERY 1 YEAR	G-23
[13] CHECK POINTS OF EVERY 2 YEARS	G-24
[14] OTHERS	G-25
8. SPECIAL TOOLS	G-27
[1] SPECIAL TOOLS FOR ENGINE	G-27
[2] SPECIAL TOOLS FOR TRACTOR	G-34
9. TIRES	G-35
[1] TIRE PRESSURE	G-35
[2] TREAD	G-35
[3] TIRE LIQUID INJECTION	G-36
10. IMPLEMENT LIMITATIONS	G-38

1. TRACTOR IDENTIFICATION

When contacting your local KUBOTA distributor, always specify engine serial number, tractor serial number and hour meter reading.

- (1) Tractor Identification Plate
- (2) Tractor Serial Number
- (3) Engine Serial Number
- (4) Hour Meter

W1010590

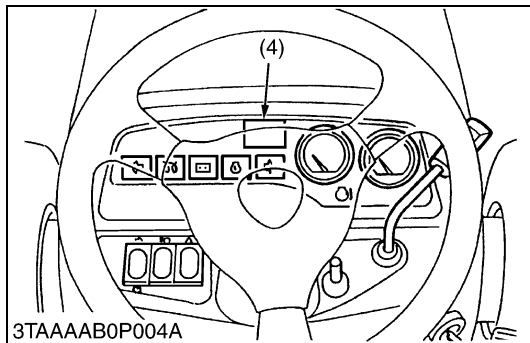
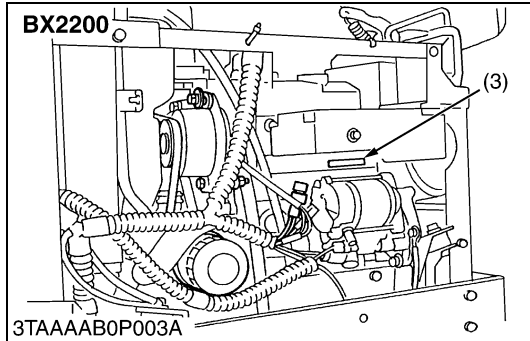
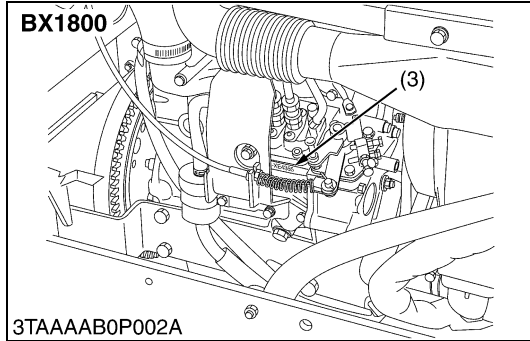
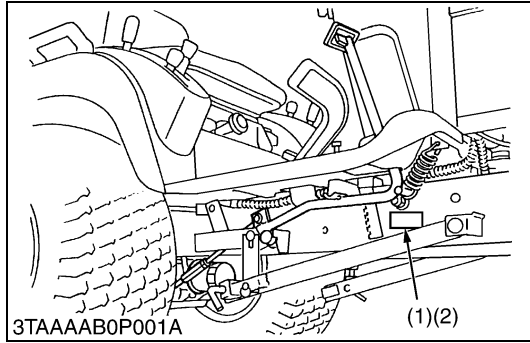

2. GENERAL PRECAUTIONS

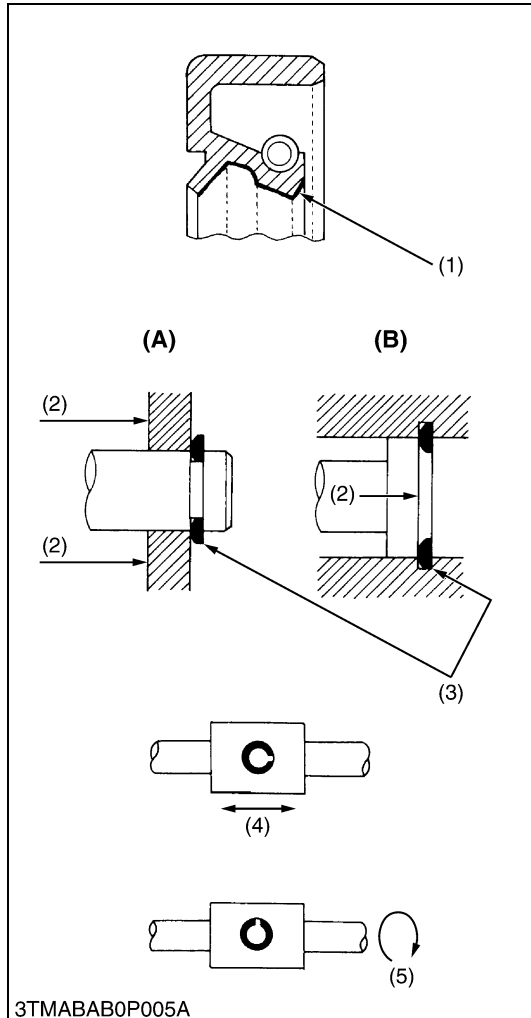

- During disassembly, carefully arrange removed parts in a clean area to prevent confusion later. Bolts and nuts should be installed in their original position to prevent reassembly errors.
- When special tools are required, use KUBOTA genuine special tools. Special tools which are not frequently used should be made according to the drawings provided.
- Before disassembling or servicing electrical wires, always disconnect the ground cable from the battery first.
- Remove oil and dirt from parts before measuring.
- Use only KUBOTA genuine parts for parts replacement to maintain tractor performance and to assure safety.
- Gaskets and O-rings must be replaced during reassembly. Apply grease to new O-rings or oil seals before assembling. See the figure left side.
- When reassembling external snap rings or internal snap rings, they must be positioned so that sharp edge faces against the direction from which a force is applied. See the figure left side.
- When inserting spring pins, their splits must face the direction from which a force is applied. See the figure left side.
- To prevent damage to the hydraulic system, use only specified fluid or equivalent.

- (1) Grease
- (2) Force
- (3) Sharp Edge
- (4) Axial Force
- (5) Rotating Movement

- (A) External Snap Ring
- (B) Internal Snap Ring

W10109040

3. HANDLING PRECAUTIONS FOR ELECTRICAL PARTS AND WIRING

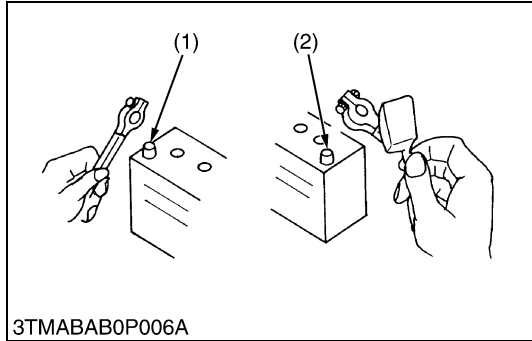

To ensure safety and prevent damage to the machine and surrounding equipment, heed the following precautions in handling electrical parts and wiring.

■ IMPORTANT

- Check electrical wiring for damage and loosened connection every year. To this end, educate the customer to do his or her own check and at the same time recommend the dealer to perform periodic check for a fee.
- Do not attempt to modify or remodel any electrical parts and wiring.
- When removing the battery cables, disconnect the negative cable first. When installing the battery cables, connect the positive cable first.

(1) Negative Terminal (2) Positive Terminal

W10111140

[1] WIRING

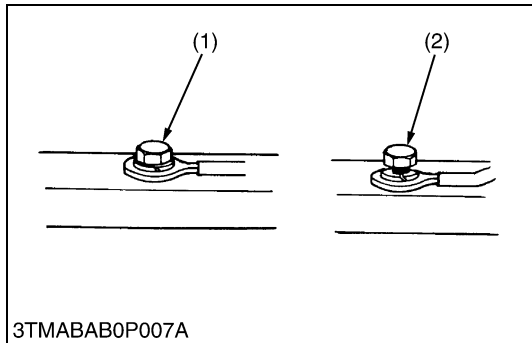

- Securely tighten wiring terminals.

(1) Correct (Securely Tighten) (2) Incorrect (Loosening Leads to Faulty Contact)

W10112160

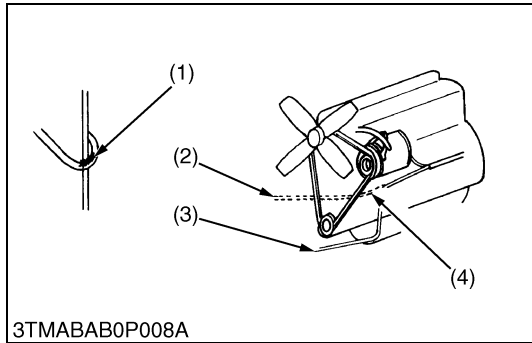

- Do not let wiring contact dangerous part.

(1) Dangerous Part (2) Wiring (Incorrect) (3) Wiring (Correct) (4) Dangerous Part

W10113130

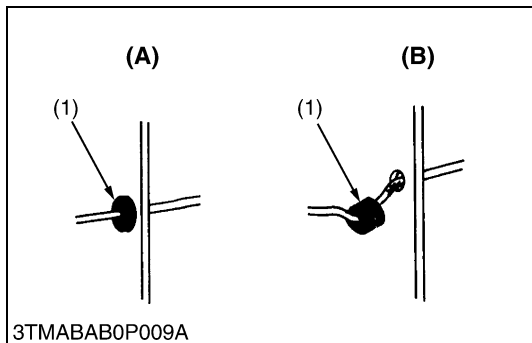

- Securely insert grommet.

(1) Grommet (A) Correct (B) Incorrect

W10113880

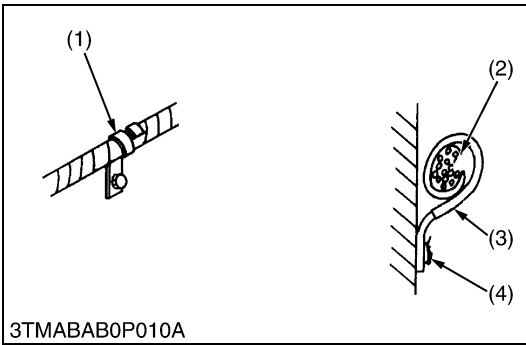

- Securely clamp, being careful not to damage wiring.

- (1) Clamp
- Wind Clamp Spirally
- (2) Wire Harness
- (3) Clamp
- (4) Welding Dent

W10114580

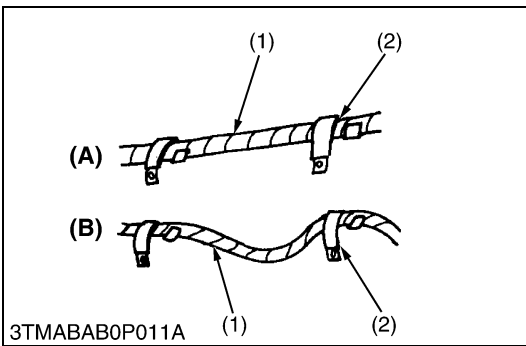

- Clamp wiring so that there is no twist, unnecessary sag, or excessive tension, except for movable part, where sag be required.

- (1) Wiring
- (2) Clamp
- (A) Correct
- (B) Incorrect

W10115870

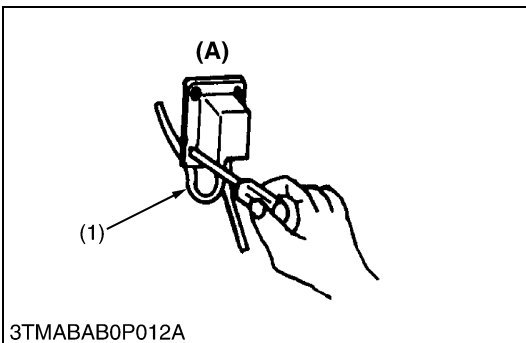

- In installing a part, take care not to get wiring caught by it.

- (1) Wiring
- (A) Incorrect

W10116700

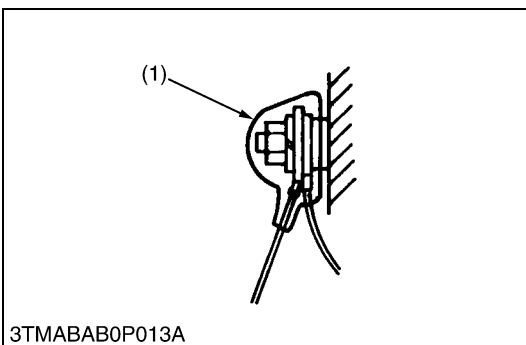

- After installing wiring, check protection of terminals and clamped condition of wiring, only connect battery.

- (1) Cover
- Securely Install Cover

W10117350

[2] BATTERY

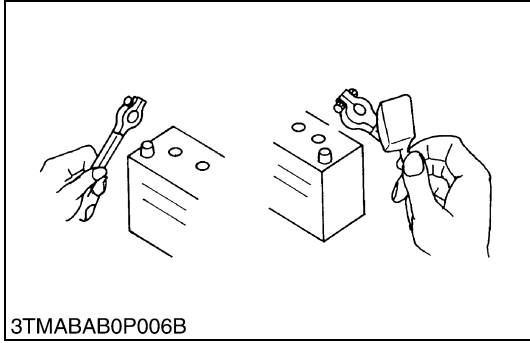

- Take care not to confuse positive and negative terminal posts.
- When removing battery cables, disconnect negative cable first. When installing battery cables, check for polarity and connect positive cable first.
- Do not install any battery with capacity other than is specified (Ah).
- After connecting cables to battery terminal posts, apply high temperature grease to them and securely install terminal covers on them.
- Do not allow dirt and dust to collect on battery.

CAUTION

- Take care not to let battery liquid spill on your skin and clothes. If contaminated, wash it off with water immediately.
- Before recharging the battery, remove it from the machine.
- Before recharging, remove cell caps.
- Do recharging in a well-ventilated place where there is no open flame nearby, as hydrogen gas and oxygen are formed.

W10118160

[3] FUSE

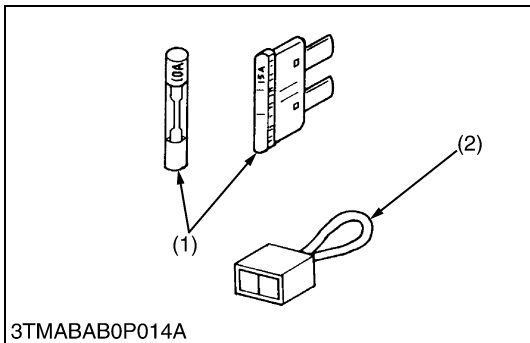

- Use fuses with specified capacity. Neither too large or small capacity fuse is acceptable.
- Never use steel or copper wire in place of fuse.
- Do not install working light, radio set, etc. on machine which is not provided with reserve power supply.
- Do not install accessories if fuse capacity of reserve power supply is exceeded.

(1) Fuse

(2) Fusible Link

W10120920

[4] CONNECTOR

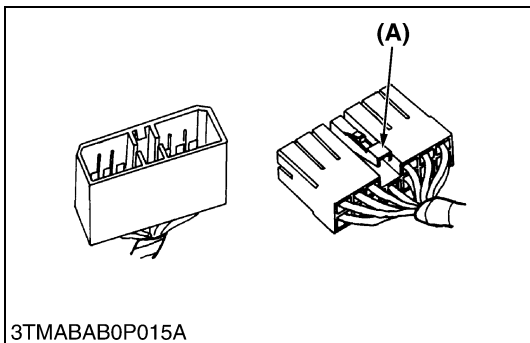

- For connector with lock, push lock to separate.

(A) Push

W10122110

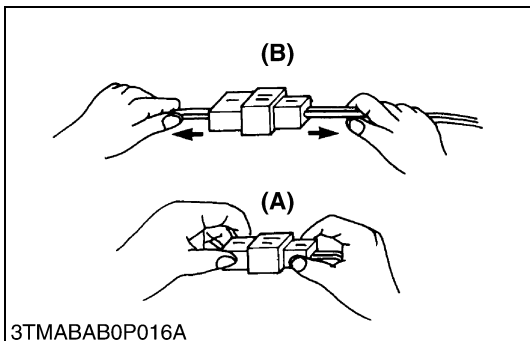

- In separating connectors, do not pull wire harnesses.
- Hold connector bodies to separate.

(A) Correct

(B) Incorrect

W10122720

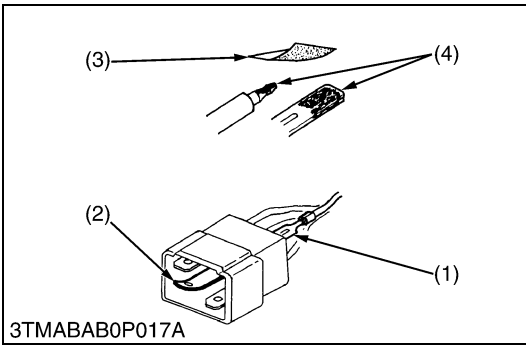

- Use sandpaper to remove rust from terminals.
- Repair deformed terminal. Make certain there is no terminal being exposed or displaced.

- (1) Exposed Terminal
- (2) Bend Terminal
- (3) Sandpaper
- (4) Rust

W10123460

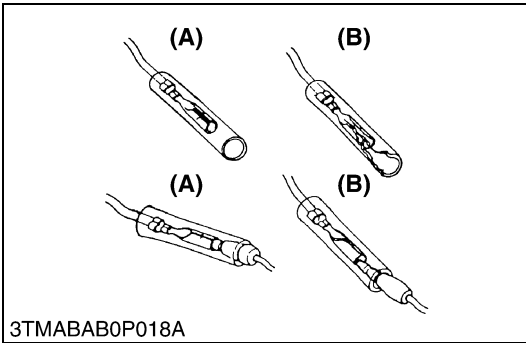

- Make certain that there is no female connector being too open.

- (A) Correct
- (B) Incorrect

W10124300

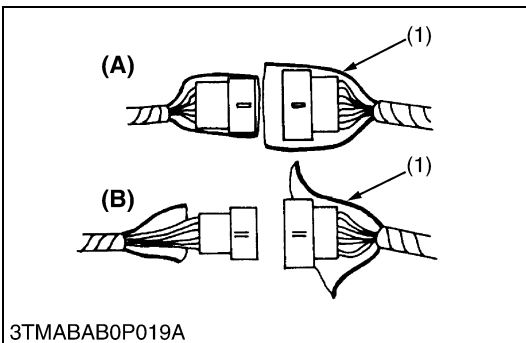

- Make certain plastic cover is large enough to cover whole connector.

- (1) Cover
- (A) Correct
- (B) Incorrect

W10125190

[5] HANDLING OF CIRCUIT TESTER

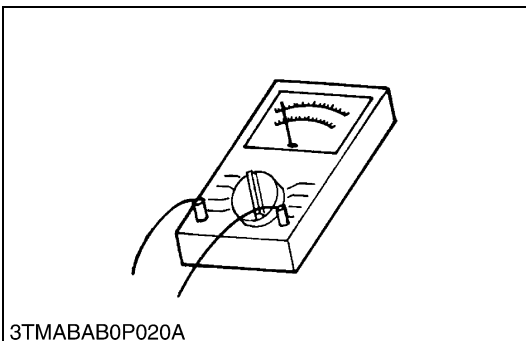

- Use tester correctly following manual provided with tester.
- Check for polarity and range.

W10126840

4. LUBRICANTS, FUEL AND COOLANT

No.	Place	Capacity		Lubricants, fuel and coolant	
		BX1800	BX2200		
1	Fuel tank	21.0 L 5.5 U.S.gals. 4.6 Imp.gals.		No. 2-D diesel fuel No. 1-D diesel fuel if temperature is below -10 °C (14 °F)	
2	Cooling system with recovery tank	2.9 L 3.06 U.S.qts. 2.55 Imp.qts.	3.5 L 3.70 U.S.qts. 3.08 Imp.qts.	Fresh clean water with anti-freeze	
3	Engine crankcase	1.9 L 2.01 U.S.qts. 1.67 Imp.qts.	2.5 L 2.64 U.S.qts. 2.20 Imp.qts.	Engine oil : API Service CC or CD Below 0 °C (32 °F) : SAE10W, 10W-30 or 10W-40 0 to 25 °C (32 to 77 °F): SAE20, 10W-30 or 10W-40 Above 25 °C (77 °F): SAE30, 10W-30 or 10W-40	
4	Transmission case	10.1 L 2.7 U.S.gals. 2.2 Imp.gals.		KUBOTA SUPER UDT fluid*	
5	Front axle case	4.7 L 4.97 U.S.qts. 4.14 Imp.qts.		KUBOTA SUPER UDT fluid* or SAE80, 90 gear oil	
Greasing					
No.	Place	No. of greasing point		Capacity	Type of grease
6	Battery terminal	2		Moderate amount	Multipurpose type grease

* KUBOTA original transmission hydraulic fluid.

5. TIGHTENING TORQUES

[1] GENERAL USE SCREWS, BOLTS AND NUTS

Screws, bolts and nuts whose tightening torques are not specified in this Workshop Manual should be tightened according to the table below.

Indication on top of bolt	4 No-grade or 4T						7 7T						9 9T		
Material of bolt	SS400, S20C						S43C, S48C						SCr435, SCM435		
Material of opponent part	Ordinariness			Aluminum			Ordinariness			Aluminum			Ordinariness		
Unit															
Diameter	N-m	kgf-m	ft-lbs	N-m	kgf-m	ft-lbs	N-m	kgf-m	ft-lbs	N-m	kgf-m	ft-lbs	N-m	kgf-m	ft-lbs
M6 (6 mm, 0.24 in.)	7.85 to 9.31	0.80 to 0.95	5.79 to 6.87	7.85 to 8.82	0.80 to 0.90	5.79 to 6.50	9.81 to 11.2	1.00 to 1.15	7.24 to 8.31	7.85 to 8.82	0.80 to 0.90	5.79 to 6.50	12.3 to 14.2	1.25 to 1.45	9.05 to 10.4
M8 (8 mm, 0.31 in.)	17.7 to 20.5	1.8 to 2.1	13.1 to 15.1	16.7 to 19.6	1.7 to 2.0	12.3 to 14.4	23.6 to 27.4	2.4 to 2.8	17.4 to 20.2	17.7 to 20.5	1.8 to 2.1	13.1 to 15.1	29.5 to 34.3	3.0 to 3.5	21.7 to 25.3
M10 (10 mm, 0.39 in.)	39.3 to 45.1	4.0 to 4.6	29.0 to 33.2	31.4 to 34.3	3.2 to 3.5	23.2 to 25.3	48.1 to 55.8	4.9 to 5.7	35.5 to 41.2	39.3 to 44.1	4.0 to 4.5	29.0 to 32.5	60.9 to 70.6	6.2 to 7.2	44.9 to 52.0
M12 (12 mm, 0.47 in.)	62.8 to 72.5	6.4 to 7.4	46.3 to 53.5	-	-	-	77.5 to 90.2	7.9 to 9.2	57.2 to 66.5	62.8 to 72.5	6.4 to 7.4	46.3 to 53.5	103 to 117	10.5 to 12.0	76.0 to 86.7
M14 (14 mm, 0.55 in.)	108 to 125	11.0 to 12.8	79.6 to 92.5	-	-	-	124 to 147	12.6 to 15.0	91.2 to 108	-	-	-	167 to 196	17.0 to 20.0	123 to 144
M16 (16 mm, 0.63 in.)	167 to 191	17.0 to 19.5	123 to 141	-	-	-	197 to 225	20.0 to 23.0	145 to 166	-	-	-	260 to 304	26.5 to 31.0	192 to 224
M18 (18 mm, 0.71 in.)	246 to 284	25.0 to 29.0	181 to 209	-	-	-	275 to 318	28.0 to 32.5	203 to 235	-	-	-	344 to 402	35.0 to 41.0	254 to 296
M20 (20 mm, 0.79 in.)	334 to 392	34.0 to 40.0	246 to 289	-	-	-	368 to 431	37.5 to 44.0	272 to 318	-	-	-	491 to 568	50.0 to 58.0	362 to 419



W1034542

[2] STUD BOLTS

Material of opponent part	Ordinariness			Aluminum		
Unit						
Diameter	N-m	kgf-m	ft-lbs	N-m	kgf-m	ft-lbs
M8 (8 mm, 0.31 in.)	11.8 to 15.6	1.2 to 1.6	8.68 to 11.5	8.82 to 11.8	0.90 to 1.2	6.51 to 8.67
M10 (10 mm, 0.39 in.)	24.6 to 31.3	2.5 to 3.2	18.1 to 23.1	19.7 to 25.4	2.0 to 2.6	14.5 to 18.8
M12 (12 mm, 0.47 in.)	29.5 to 49.0	3.0 to 5.0	21.7 to 36.1	31.4	3.2	23.1

W10481390

[3] AMERICAN STANDARD SCREWS, BOLTS AND NUTS WITH UNC OR UNF THREADS

Grade Unit Nominal Diameter	SAE GR.5 			SAE GR.8 		
	N-m	kgf-m	ft-lbs	N-m	kgf-m	ft-lbs
5/16	23.1 to 27.8	2.35 to 2.84	17.0 to 20.5	32.5 to 39.3	3.31 to 4.01	24.0 to 29.0
3/8	47.5 to 57.0	4.84 to 5.82	35.0 to 42.0	61.0 to 73.2	6.22 to 7.47	45.0 to 54.0
1/2	108.5 to 130.2	11.07 to 13.29	80.0 to 96.0	149.2 to 179.0	15.22 to 18.27	110.0 to 132.0
9/16	149.2 to 179.0	15.22 to 18.27	110.0 to 132.0	217.0 to 260.4	22.14 to 26.57	160.0 to 192.0
5/8	203.4 to 244.1	20.75 to 24.91	150.0 to 180.0	298.3 to 358.0	30.44 to 36.53	220.0 to 264.0

W1022485

7. CHECK AND MAINTENANCE



CAUTION

- **Be sure to check and service the tractor on a flat place with engine shut off, the parking brake on and chock the wheels.**

[1] DAILY CHECK

To prevent trouble from occurring, it is important to know the condition of the tractor. Check the following items before starting.

Checking

- Check areas where previous trouble was experienced.
- Walk around the tractor.
 1. Check the tire pressure, and check for wear and damage.
 2. Check for oil and water leaks.
 3. Check the engine oil level.
 4. Check the transmission fluid level.
 5. Check the coolant level.
 6. Check the condition of seat belt and ROPS attaching hardware.
 7. Check and clean the radiator screen and grill.
 8. Check the bolts and nuts of tires are tight.
 9. Check the number plate or SMV emblem for damage and cleaner replace as necessary if equipped.
 10. Care of danger, warning and caution labels.
 11. Clean around the exhaust manifold and the muffler of the engine.
- While sitting in the operator's seat.
 1. Check the HST pedal and brake pedals.
 2. Check the parking brake.
 3. Check the steering wheel.
- Turning the key switch.
 1. Check the performance of the easy checker lights.
 2. Check head lights, tail lights and hazard lights. Clean if necessary.
 3. Check the performance of the meters and gauges.
- Starting the engine.
 1. Check to see that the lights on the Easy Checker go off.
 2. Check the color of the exhaust gas.
 3. Check the brakes for proper operation.

[2] CHECK POINTS OF INITIAL 50 HOURS

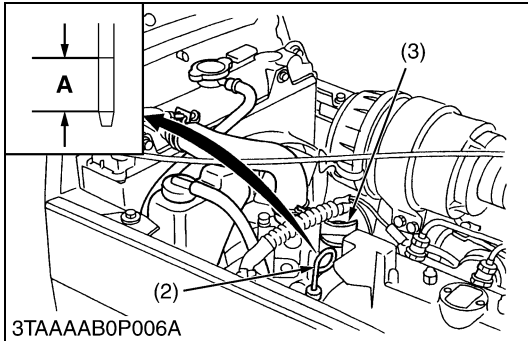
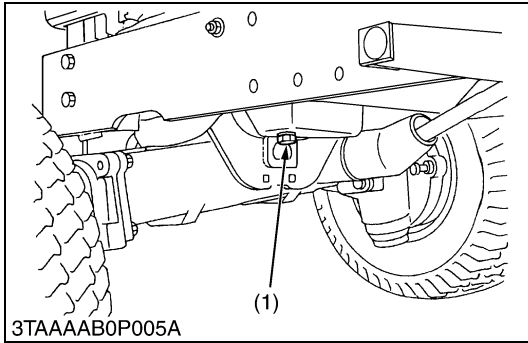

Changing Engine Oil

⚠ CAUTION

- **Be sure to stop the engine before changing engine oil.**
- 1. Start and warm up the engine for approx. 5 minutes.
- 2. Place an oil pan underneath the engine.
- 3. To drain the used oil, remove the drain plug (1) at the bottom of the engine and drain the oil completely.
- 4. Screw in the drain plug (1).
- 5. Fill new oil up to upper line on the dipstick (2).

■ IMPORTANT

- **When using an oil of different manufacture or viscosity from the previous one, remove all of the old oil.**
- **Never mix two different types of oil.**
- **Use the proper SAE Engine Oil according to ambient temperatures.**
- **Refer to "LUBRICANTS, FUEL AND COOLANT". (See page G-7.)**

Engine oil capacity	BX1800	1.9 L 2.01 U.S.qts. 1.67 Imp.qts.
	BX2200	2.5 L 2.64 U.S.qts. 2.20 Imp.qts.

- (1) Drain Plug
- (2) Dipstick
- (3) Oil Inlet

A : Oil level is acceptable within this range.

W1014065

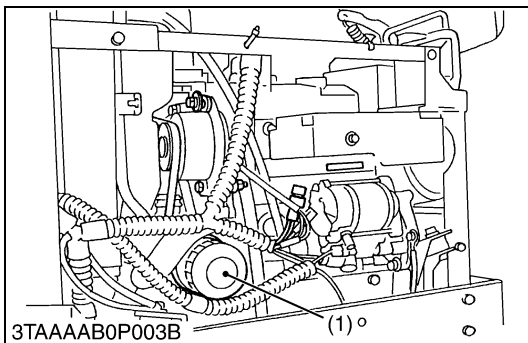

Replacing Engine Oil Filter Cartridge

⚠ CAUTION

- **Be sure to stop the engine before changing oil filter cartridge.**
- 1. Remove the oil filter cartridge with the filter wrench.
- 2. Apply a slight coat of oil onto the cartridge gasket.
- 3. To install the new cartridge, screw it in by hand. Over tightening may cause deformation of rubber gasket.
- 4. After the new cartridge has been replaced, the engine oil normally decrease a little. Thus see that the engine oil does not leak through the seal and be sure to read the oil level on the dipstick. Then, replenish the engine oil up to the specified level.

■ IMPORTANT

- **To prevent serious damage to the engine, replacement element must be highly efficient. Use only a KUBOTA genuine filter or its equivalent.**

- (1) Engine Oil Filter Cartridge

W1014316

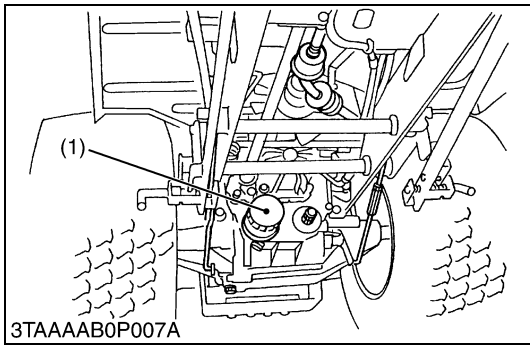

Replacing Transmission Oil Filter Cartridge

CAUTION

- **Be sure to stop the engine before changing the oil filters.**
- 1. Remove the oil filter cartridge by using a filter wrench.
- 2. Apply a slight coat of oil onto the cartridge gasket.
- 3. To install the new cartridge, screw it in by hand. Over tightening may cause deformation of rubber gasket.
- 4. After the new cartridge has been replaced, the transmission fluid level will normally decrease slightly. Make sure that the transmission fluid does not leak through the seal. Check the fluid level.

IMPORTANT

- **To prevent serious damage to the hydraulic system. Use only a genuine KUBOTA filter or its equivalents.**

(1) Transmission Oil Filter Cartridge

W1014458

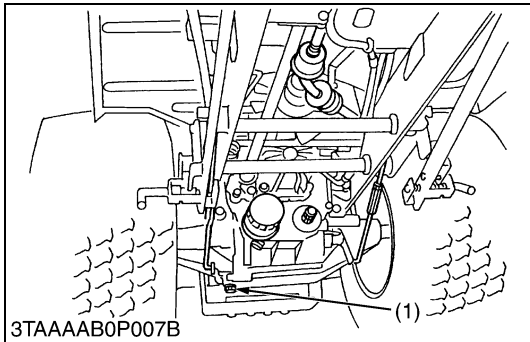

Changing Transmission Fluid

CAUTION

- **Be sure to stop the engine before changing the transmission fluid.**
- 1. Place an oil pan under the tractor.
- 2. Remove the drain plugs (1) at the bottom of the transmission case and drain the oil completely.
- 3. After draining, screw in the drain plug.
- 4. Fill new oil from filling port after removing the filling plug (2) up to the upper notch on the dipstick.
- 5. After running the engine for a few minutes, stop it and check the oil level again, if low, add oil to prescribed level.

IMPORTANT

- **Use only multi-grade transmission oil. Use of other oils may damage the transmission or hydraulic system. Refer to “LUBRICANTS, FUEL AND COOLANT”. (See page G-7.)**
- **Never work the tractor immediately after changing the transmission oil. Keeping the engine at medium speed for a few minutes to prevents damage to the transmission.**
- **Do not mix different brands oil together.**

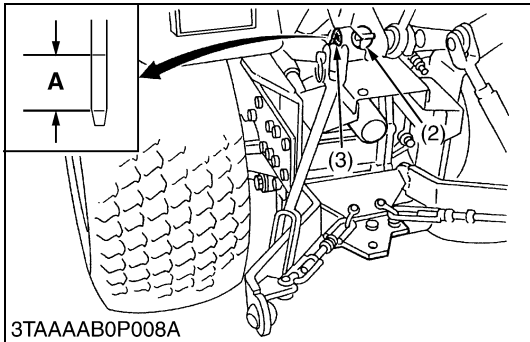

Transmission fluid capacity	10.1 L 2.7 U.S.gals. 2.2 Imp.gals.
-----------------------------	--

- (1) Drain Plug
- (2) Filling Plug
- (3) Dipstick

A : Oil level is acceptable within this range.

W1014665

[3] CHECK POINTS OF EVERY 50 HOURS

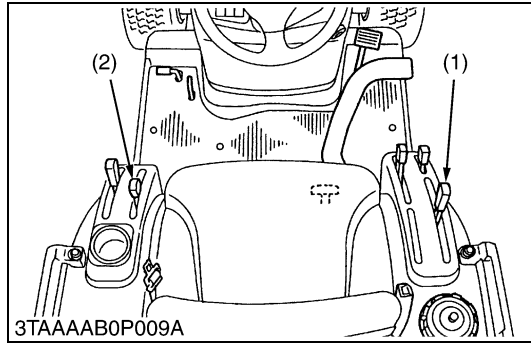

Checking Engine Start System

⚠ CAUTION

- Do not allow anyone near the tractor while testing.
- If the tractor does not pass the test do not operate the tractor.

■ Preparation before testing.

1. Sit on operator's seat.
2. Set the parking brake and stop the engine.
3. Shift the range gear shift lever in "NEUTRAL" position.
4. Shift the PTO clutch lever to "OFF" position.

■ Test 1 : Safety switch on the range gear shift linkage

1. Shift the range gear shift lever to "LOW" or "HIGH" position.
2. Turn the key to "START" position.
3. The engine must not crank.

■ Test 2 : Safety switch on the PTO clutch lever

1. Shift the range gear shift lever to "NEUTRAL" position.
2. Shift the PTO clutch lever to "ON" position.
3. Turn the key to "START" position.
4. The engine must not crank.

(1) Range Gear Shift Lever

(2) PTO Clutch Lever

W1014904

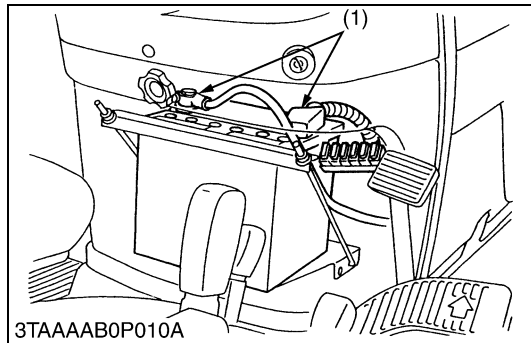

Greasing

1. Apply a small amount of grease to the battery terminals (1).

(1) Battery Terminal

W1015242

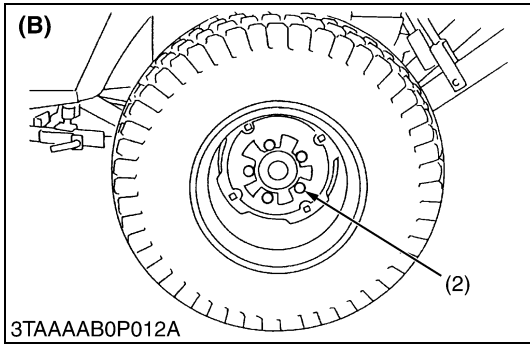
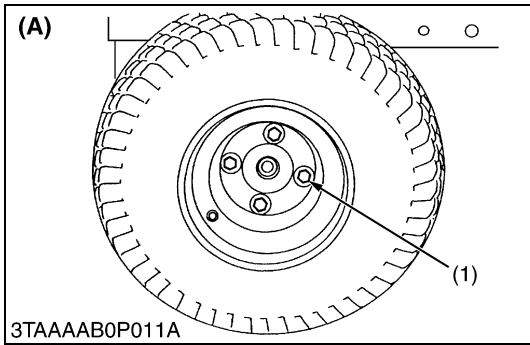

Checking Wheel Mounting Screws Tightening Torque

CAUTION

- Never operate tractor with a loose rim, wheel, or axle.
 - Any time screws are loosened, retighten to specified torque.
 - Check all screws frequently and keep them tight.
1. Check wheel screws regularly especially when new. If there are loosened, tighten as follows.

Tightening torque	Front wheel mounting screws	149.2 to 179.0 N·m 15.3 to 18.2 kgf·m 110 to 132 ft-lbs
	Rear wheel mounting screws	108.5 to 130.2 N·m 11.1 to 13.2 kgf·m 80 to 96 ft-lbs

- (1) Front Wheel Mounting Screw (A) Front
(2) Rear Wheel Mounting Screw (B) Rear

W1015311

[4] CHECK POINTS OF EVERY 100 HOURS

Changing Engine Oil

1. See page G-12.

W1015501

Checking Battery Condition

DANGER

- To avoid the possibility of battery explosion:
For the refillable type battery, follow the instructions below.
- Do not use or charge the refillable type battery if the fluid level is below the LOWER (lower limit level) mark. Otherwise, the battery component parts may prematurely deteriorate, which may shorten the battery's service life or cause an explosion. Check the fluid level regularly and add distilled water as required so that the fluid level is between the UPPER and LOWER levels.

CAUTION

- Never remove the vent plugs while the engine is running.
 - Keep electrolyte away from eyes, hands and clothes. If you are splattered with it, wash it away completely with water immediately and get medical attention.
 - Wear eye protection and rubber gloves when working around battery.
1. Mishandling the battery shortens the service life and adds to maintenance costs.
2. The original battery is maintenance free type battery, but need some servicing.
If the battery is weak, the engine is difficult to start and the lights become dim. It is important to check the battery periodically.

- (1) Battery (2) Vent Plug

W1015551

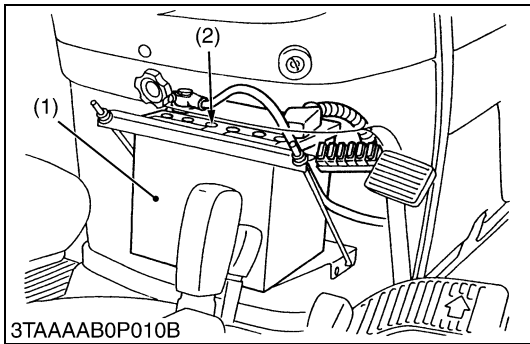

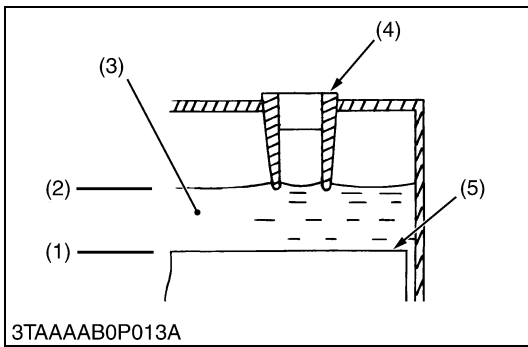

■ Battery Charging

⚠ CAUTION

- When the battery is being activated, hydrogen and oxygen gases in the battery are extremely explosive. Keep open sparks and flames away from the battery at all times, especially when charging the battery.
- When charging the battery, ensure the vent caps are securely in place (if equipped).
- When disconnecting the cable from the battery, start with the negative terminal first.
When connecting the cable to the battery, start with the positive terminal first.
- Never check battery charge by placing a metal object across the posts.
Use a voltmeter or hydrometer.

1. Make sure each electrolyte level is to the bottom of vent wells, if necessary add distilled water in a well-ventilated area.
2. The water in the electrolyte evaporates during recharging. Liquid shortage damages the battery. Excessive liquid spills over and damages the tractor body.
3. To slow charge the battery, connect the battery positive terminal to the charger positive terminal and the negative to the negative, then recharge in the standard fashion.
4. A boost charge is only for emergencies. It will partially charges the battery at a high rate and in a short time.
When using a boost-charged battery, it is necessary to recharge the battery as early as possible.
Failure to do this will shorten the battery's service life.
5. When the specific gravity of electrolyte become between 1.27 and 1.29 charge has completed.
6. When exchanging an old battery into new one, use battery of equal specification shown in table 1.

Table 1

Tractor Type	Battery Type	Volts (V)	Reserve Capacity (min.)	Cold Cranking Amps
BX1800	26/26R	12	62	435
BX2200	526RA	12	80	535

■ Direction for Storage

1. When storing the tractor for long periods of time, remove the battery from tractor, adjust the electrolyte to the proper level and store in a dry place out of direct sunlight.
2. The battery self-discharges while it is stored.
Recharge it once every three months in hot seasons and once every six months in cold seasons.

- (1) Lowest Level
- (2) Highest Level
- (2) Electrolyte
- (4) Vent Well
- (5) Separator

W1019057

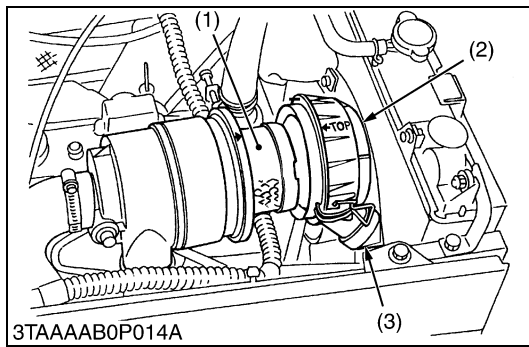

Cleaning Air Cleaner Element

1. Remove the air cleaner cover (2) and element (1).
2. Clean the element if:
 - When dry dust adheres to the element, blow compressed air from the inside, turning the element. Pressure of compressed air must be under 205 kPa (2.1 kgf/cm², 30 psi).
 - When carbon or oil adheres to the element, soak the element in detergent for 15 minutes then wash it several times in water, rinse with clean water and dry it naturally. After element is fully dried, inspect inside of the element with a light and check if it is damaged or not.
3. Replace the element (1) once a year or after every six times of cleaning, whichever comes first.

■ IMPORTANT

- **The air cleaner uses a dry element, never apply oil.**
- **Do not run the engine with filter element removed.**
- **Be sure to refit the dust cup with the arrow ↑ upright. If the dust cup is improperly fitted, evacuator valve will not function and dust will adhere to the element.**

■ Evacuator Valve

Open the evacuator valve once a week under ordinary conditions or daily when used in a dusty place to get rid of large particles of dust and dirt.

(1) Element
(2) Cover

(3) Evacuator Valve

W1017166

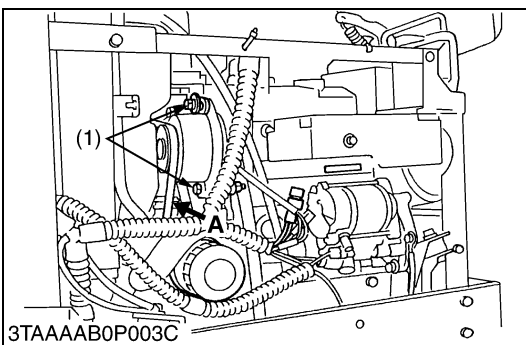
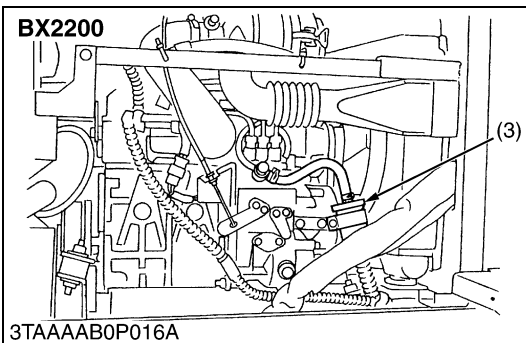
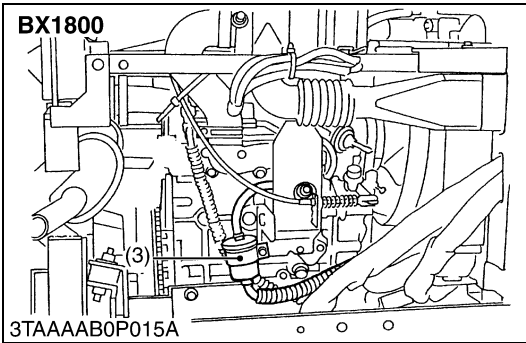
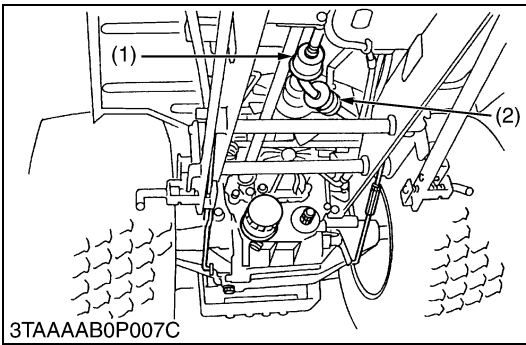

Checking Fuel Lines and Fuel Filter

1. The fuel line is made of rubber and ages regardless of service period.
2. After inspection, if the fuel line and clamps are found damaged or deteriorated, replace them.
3. Check fuel filter, if it is clogged by debris or contaminated by water, replace it.

■ **IMPORTANT**

- When the fuel line is disconnected for maintenance or repair, plug both ends of the fuel line with a clean plug of suitable size to prevent dust and dirt from entering. Particular care must be taken not to admit dust and dirt into the fuel system. Entrance of dust and dirt causes malfunction of the fuel pump.

■ **NOTE**

- If the fuel line is removed, be sure to properly bleed the fuel system (see page G-25).

- (1) Fuel Pump (3) Fuel Filter
(2) Fuel Filter

W1017546

Checking Fan Belt Tension

⚠ CAUTION

- Be sure to stop engine before checking belt tension.

1. Stop the engine and remove the key.
2. Apply moderate thumb pressure to belt between pulleys.
3. If tension is incorrect, loosen the alternator mounting bolts and using a lever placed between the alternator and the engine block, pull the alternator out until the deflection of the belt falls within acceptable limits.
4. Replace fan belt if it is damaged.

Fan belt tension	Factory spec.	A deflection of between 7 to 9 mm (0.28 to 0.34 in.) when the belt is pressed in the middle of the span.
------------------	---------------	--

(1) Mounting Bolt

A : Check the belt tension

W1017708

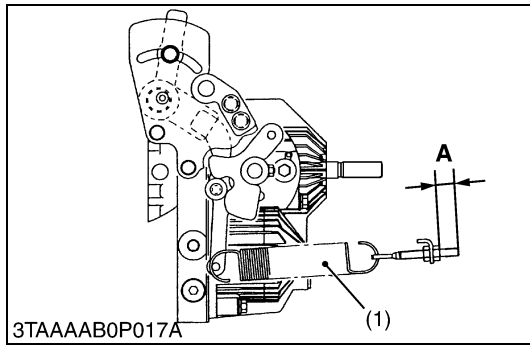

3TAAAB0P017A

Adjusting HST Neutral Spring (Speed Control Pedal)

⚠ CAUTION

- To avoid personal injury:
Do not operate if tractor moves on level ground with foot off speed control pedal.

1. Start the engine and set at low idle (approx. 1500 min⁻¹ (rpm)).
2. Shift the range gear shift lever to **HIGH** position.
3. Move the speed control pedal from forward or reverse position to neutral position to check the tractor movement. The tractor should come to a complete stop.
4. If the speed control pedal is too slow in returning to neutral position, adjust the HST neutral spring setting.

■ IMPORTANT

- Do not set the length A more than 40 mm (1.57 in.)

Length A	Factory spec.	5 to 40 mm 0.20 to 1.57 in.
----------	---------------	--------------------------------

(1) HST Neutral Spring

W1017963

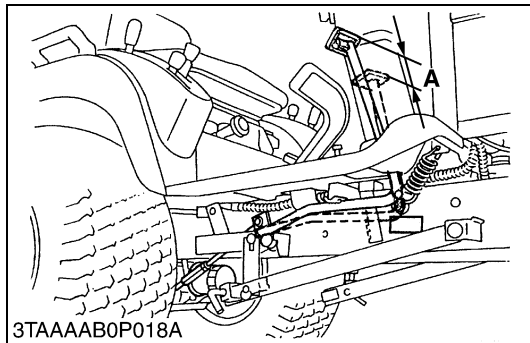

3TAAAB0P018A

Adjusting Brake Pedal Free Travel

⚠ CAUTION

- Stop the engine, remove the key, lower the implement to the ground, and chock the wheels before checking brake pedal.
- Even if the brake pedal free travel is within the limitation, adjust the brake pedal following the procedure below.

1. Release the parking brake.
2. Loosen the RH lock nut and extend the RH turnbuckle to the end of the thread.
3. Loosen the LH lock nut and turn the LH turnbuckle to adjust the LH rod length so that the brake pedal free travel is 20 mm (0.79 in.).
4. Retighten the LH lock nut.
5. Adjust the RH rod length so that the brake pedal free travel is 10 mm (0.39 in.).
6. Extend the RH turnbuckle one additional turn.
7. Retighten the RH lock nut.
8. Depress the brake pedal several times and make sure the brake pedal free travel is from 20 to 30 mm (0.79 to 1.18 in.).

Brake pedal free travel	Factory spec.	20 to 30 mm 0.79 to 1.18 in.
-------------------------	---------------	---------------------------------

(1) Lock Nut
(2) Turnbuckle

A : Free Travel

W1018144

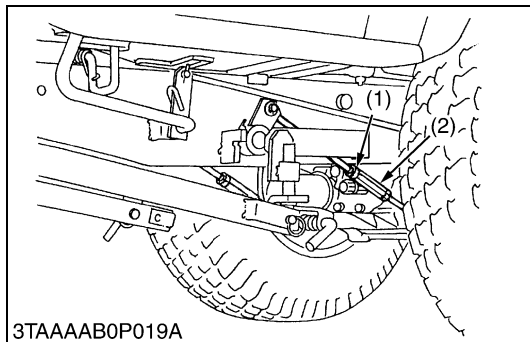

3TAAAB0P019A

[5] CHECK POINTS OF EVERY 200 HOURS

Replacing Engine Oil Filter Cartridge

1. See page G-12.

W1018516

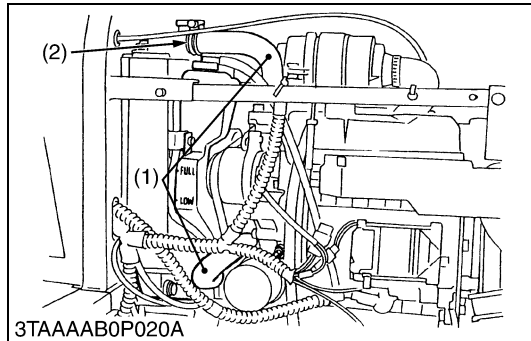

Checking Radiator Hose and Hose Clamp

Check to see if radiator hoses are properly fixed every 200 hours of operation or six months, whichever comes first.

1. If hose clamps are loose or water leaks, tighten bands securely.
2. Replace hoses and tighten hose clamps securely, if radiator hoses are swollen, hardened or cracked.

Replace hoses and hose clamps every 2 years or earlier if checked and found that hoses are swollen, hardened or cracked.

■ Precaution at Overheating

Take the following actions in the event the coolant temperature be nearly or more than the boiling point, what is called “Overheating”.

1. Stop the machine operation in a safe place and keep the engine unloaded idling.
2. Don't stop the engine suddenly, but stop it after about 5 minutes of unloaded idling.
3. Keep yourself well away from the machine for further 10 minutes or while the steam blown out.
4. Checking that there gets no danger such as burn, get rid of the causes of overheating according to the manual, see “**Troubleshooting**” section, and then, start again the engine.

(1) Radiator Hose

(2) Clamp

W1018562

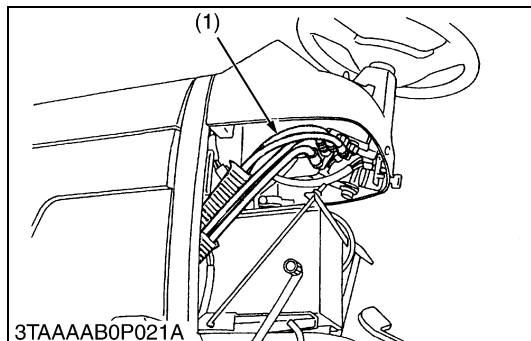

Checking Power Steering Line

1. Check to see that all lines are tight and not damaged.
2. If hoses are found to be worn or damaged, replace or repair them at once.

(1) Power Steering Hose

W1018751

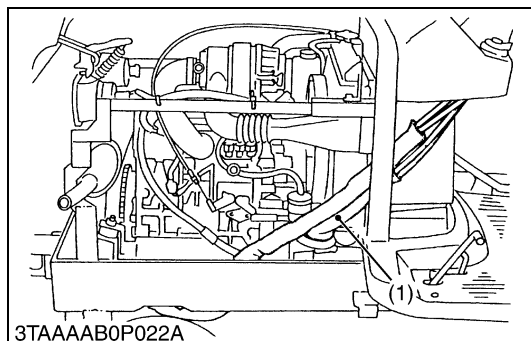

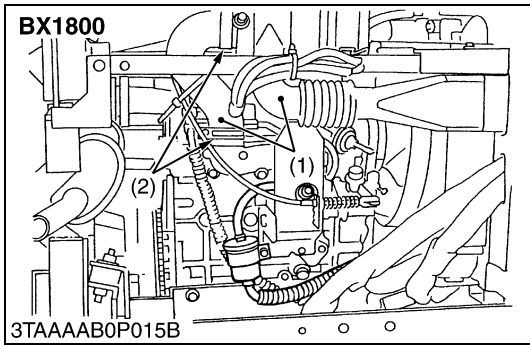

Checking Intake Air Line

1. Check to see that hoses and hose clamps are tight and not damaged.
2. If hoses and clamps are found to be worn or damaged, replace or repair them at once.

(1) Hose (2) Hose Clamp

W1018915

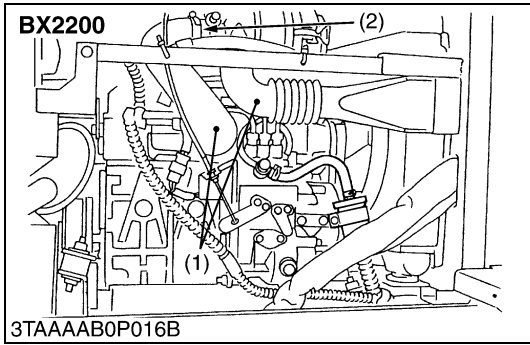

Adjusting Toe-in

1. Park the tractor on the flat place.
2. Inflate the tires to the specified pressure.
3. Turn steering wheel so front wheels are in the straight ahead position.
4. Lower the implement, lock the parking brake and stop the engine.
5. Measure distance between tire beads at front of tire, hub height.
6. Measure distance between tire beads at rear of tire, hub height.
7. Front distance should be 1 to 10 mm (0.039 to 0.39 in.) less than rear distance.
8. If the measurement is not within the factory specifications, adjust by changing the steering tie-rod length.

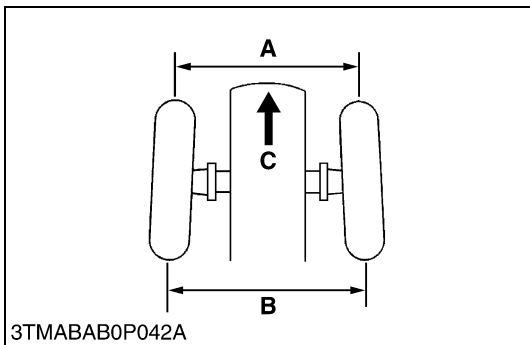

Toe-in (B - A)	Factory spec.	1 to 10 mm 0.039 to 0.39 in.
----------------	---------------	---------------------------------

Adjusting

1. Loosen the lock nuts and turn the steering tie-rod to adjust the rod length until the proper toe-in measurement is obtained.
2. Retighten the lock nuts.

(1) Lock Nut
(2) Steering Tie-rod

(A) Wheel to Wheel Distance at Front
(B) Wheel to Wheel Distance at Rear
(C) Front

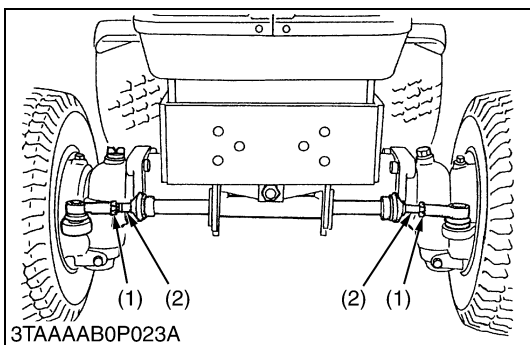

W1019009

[6] CHECK POINTS OF EVERY 300 HOURS

Replacing Transmission Oil Filter Cartridge

1. See page G-13.

W1019345

Changing Transmission Fluid

1. See page G-13.

W1019295

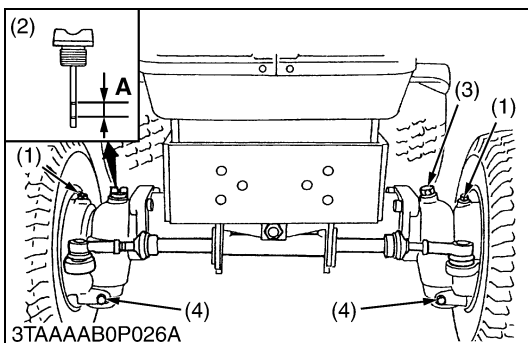
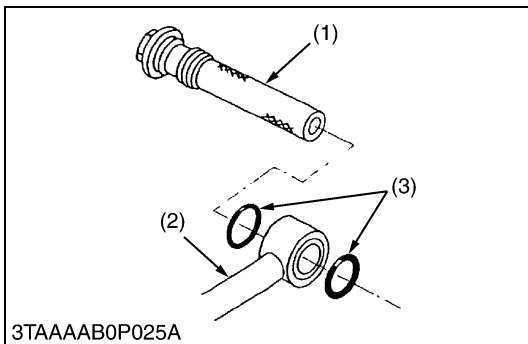
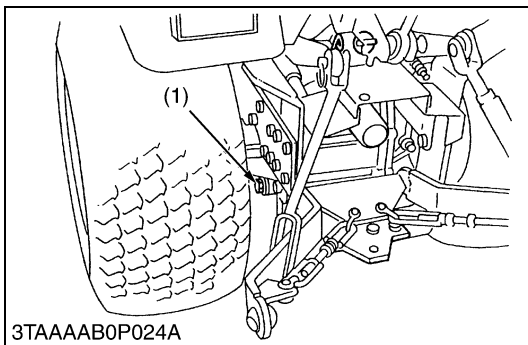

Cleaning Transmission Oil Strainer

1. Remove the strainer and clean with nonflammable solvent.

■ **NOTE**

- When reassembling be careful not to damage the parts.
- Since the fine fillings in the oil can damage the precision component parts of the hydraulic system precision built to withstand high pressure, the end of the suction line is provided with an oil strainer.

- (1) Strainer (3) O-ring
 (2) Suction Line

W1019390

Changing Front Axle Case Oil

1. Park the machine on a firm, flat and level surface.
2. To drain the used oil, remove the right and left drain plugs and filling plug at the front axle case and drain the oil completely into the oil pan.
3. After draining reinstall the drain plugs.
4. Remove the right and left breather plugs.
5. Fill with new oil up to the upper notch on the dipstick.
6. After filling, reinstall the filling plug and breather plug.

■ **IMPORTANT**

- After ten minutes, check the oil level again; add oil to prescribed level.

Front axle case oil capacity	4.7 L 4.97 U.S.qts. 4.14 Imp.qts.
------------------------------	---

- (1) Breather Pipe
 (2) Filling Plug with Dipstick
 (3) Filling Plug
 (4) Drain Plug

A : Oil level is acceptable within this range.

W1019508

[7] CHECK POINTS OF EVERY 400 HOURS

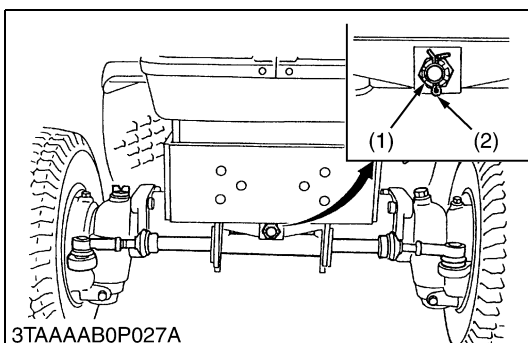

Adjusting Front Axle Pivot

1. Remove the cotter pin (2) and tighten the adjusting nut (1) to the specified torque.
2. Make sure one of the nut slots aligns with the cotter pin hole, tighten the nut slightly if necessary to align.
3. Install the new cotter pin.

Tightening torque	Factory spec.	19.6 N·m 2.0 kgf·m 14.5 ft-lbs
-------------------	---------------	--------------------------------------

- (1) Adjusting Nut (2) Cotter Pin

W1019713

[8] CHECK POINTS OF EVERY 500 HOURS

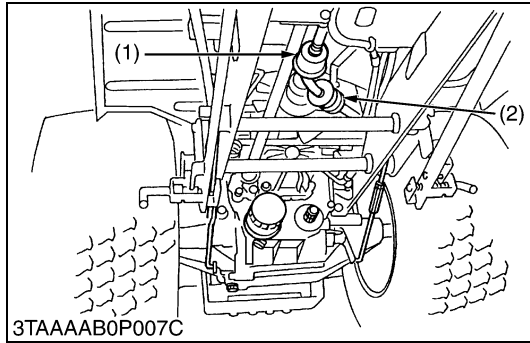

Replacing Fuel Filter

1. Disconnect the fuel hoses and replace the fuel filter (2).
2. Disconnect the fuel hoses and loosen the filter band to replace the fuel filter (3).

■ NOTE

- If the fuel line is removed, be sure to properly bleed the fuel system (see page G-25).

- (1) Fuel Pump
(2) Fuel Filter

- (3) Fuel Filter

W1019858

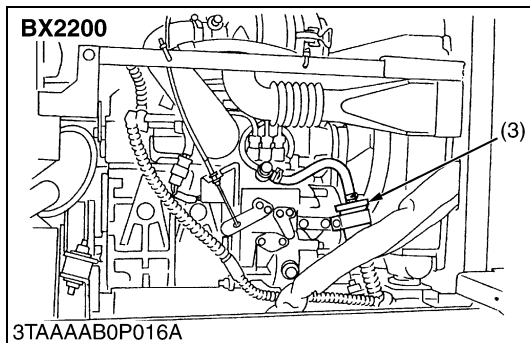
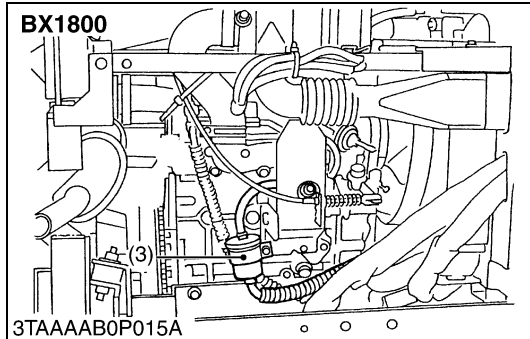

[9] CHECK POINTS OF EVERY 800 HOURS

Adjusting Engine Valve Clearance

1. See page 1-S22.

W1019995

[10] CHECK POINTS OF EVERY 1500 HOURS

Checking Fuel Injection Nozzle Injection Pressure

1. See page 1-S68.

W1020203

[11] CHECK POINTS OF EVERY 3000 HOURS

Checking Injection Pump

1. See page 1-S66.

W1020260

[12] CHECK POINTS OF EVERY 1 YEAR

Replacing Air Cleaner Element

1. See page G-17.

W1020343

[13] CHECK POINTS OF EVERY 2 YEARS

Replacing Radiator Hose (Water Pipes)

1. Replace the hoses and clamps.
Refer to “Checking Radiator Hose and Hose Clamp”.
(See page G-20.)

W1020468

Replacing Power Steering Hose

1. Replace the hoses.
Refer to “Checking Power Steering Line”.
(See page G-20.)

W1020513

Replacing Fuel Hose

1. Replace the hoses and clamps.
Refer to “Checking Fuel Lines and Fuel Filter”.
(See page G-18.)

W1020558

Replacing Intake Air Line

1. Refer to “Checking Intake Air Line”.
(See page G-21.)

W1020422

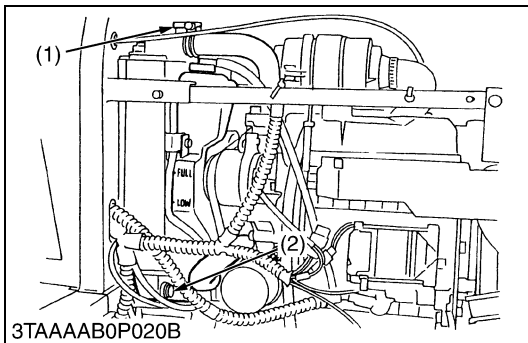

Flush Cooling System and Changing Coolant

⚠ CAUTION

- **Do not remove the radiator cap when the engine is hot. Then loosen cap slightly to the stop to relieve any excess pressure before removing cap completely.**
1. Stop the engine and let cool down.
 2. To drain the coolant, open the radiator drain cock, and remove radiator cap. The radiator cap must be removed to completely drain the coolant.
 3. After all coolant is drained, close the drain plug.
 4. Fill with clean water and cooling system cleaner.
 5. Follow directions of the cleaner instruction.
 6. After flushing, fill with clean water and anti-freeze until the coolant level is just below the port.
Install the radiator cap securely.
 7. Fill with coolant up to “**FULL**” mark on the recovery tank.
 8. Start and operate the engine for few minutes.
 9. Stop the engine, remove the key and let cool.
 10. Check coolant level of recovery tank and add coolant if necessary.

■ IMPORTANT

- **Do not start engine without coolant.**
- **Use clean, fresh water and anti-freeze to fill the radiator.**
- **When the anti-freeze is mixed with water, the anti-freeze mixing ratio must be less than 50 %.**
- **Securely tighten radiator cap. If the cap is loose or improperly fitted, water may leak out and the engine could overheat.**

Coolant capacity (with recovery tank)	BX1800	2.9 L 3.06 U.S.qts. 2.55 Imp.qts.
	BX2200	3.5 L 3.70 U.S.qts. 3.08 Imp.qts.

(1) Radiator Cap

(2) Drain Plug

W1021307

KiSC issued 07, 2006 A

Flash Cooling System and Changing Coolant (Continued)

■ Anti-Freeze

If coolant freezes, it can damage the cylinders and radiator. It is necessary, if the ambient temperature falls below 0 °C (32 °F), to remove coolant after operating or to add anti-freeze to it.

1. There are two types of anti-freeze available; use the permanent type (PT) for this engine.
2. Before adding anti-freeze for the first time, clean the radiator interior by pouring fresh water and draining it a few times.
3. The procedure for mixing of water and anti-freeze differs according to the make of the anti-freeze and the ambient temperature, basically it should be referred to SAE J1034 standard, more specifically also to SAE J814c.
4. Mix the anti-freeze with water, and then fill in to the radiator.

Vol % Anti-freeze	Freezing Point		Boiling Point*	
	°C	°F	°C	°F
40	-24	-12	106	222
50	-37	-34	108	226

* At 760 mmHg pressure (atmospheric). A higher boiling point is obtained by using a radiator pressure cap which permits the development of pressure within the cooling system.

■ NOTE

- The above data represent industry standards that necessitate a minimum glycol content in the concentrated anti-freeze.
- When the coolant level drops due to evaporation, add water only. In case of leakage, add anti-freeze and water in the specified mixing ratio.
- Anti-freeze absorbs moisture. Keep unused anti-freeze in a tightly sealed container.
- Do not use radiator cleaning agents when anti-freeze has been added to the coolant. (Anti-freeze contains an anti-corrosive agent, which will react with the radiator cleaning agent forming sludge which will affect the engine parts.)

W1022492

[14] OTHERS

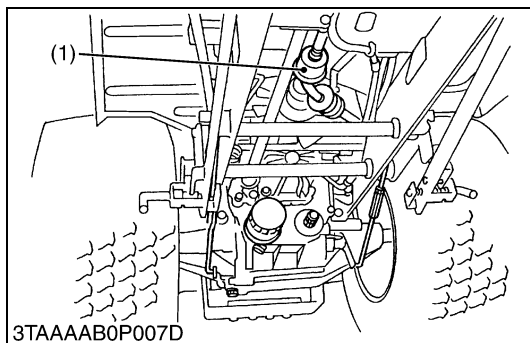

Bleeding Fuel System

Air must be removed:

1. When the fuel filter or lines are removed.
2. When tank is completely empty.
3. After the tractor has not been used for a long period of time.

Bleeding procedure is as follows:

1. Fill the fuel tank with fuel.
2. Turn the key switch to “ON” position for about 30 seconds. Doing so allows fuel pump work and pump air out of the fuel system.
3. Start the engine and run for about 30 seconds, and then stop the engine.

(1) Fuel Pump

W1021149

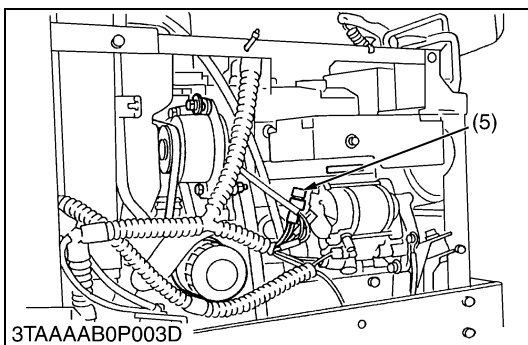
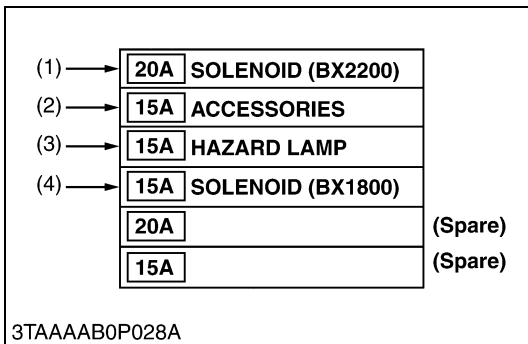
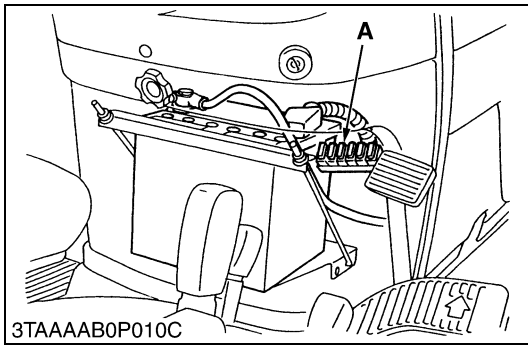

Replacing Fuse

1. The tractor electrical system is protected from potential damage by fuses.

A blown fuse indicates that there is an overload or short somewhere in the electrical system.

2. If any of the fuses should blow, replace with a new one of the same capacity.

■ IMPORTANT

- Before replacing a blown fuse, determine why the fuse blew and make any necessary repairs. Failure to follow this procedure may result in serious damage to the tractor electrical system.

■ Protected Circuit

Fuse No.	Capacity (A)	Protected circuit
1	20	Key stop (BX2200)
2	15	Head lights
3	15	Hazard lights
4	15	Key stop (BX1800)
5	Slow blow fuse	Check circuit against wrong battery connection

A : Fuse Box

W1023430

Replacing Light Bulb

1. Head lights:

Take the bulb out of the light body and replace with a new one.

2. Other lights:

Detach the lens and replace the bulb.

Light	Capacity
Head lights	24 W
Tail light	3 W
Hazard light	20 W
Additional turn signal lamp	20 W

W1023802

8. SPECIAL TOOLS

[1] SPECIAL TOOLS FOR ENGINE

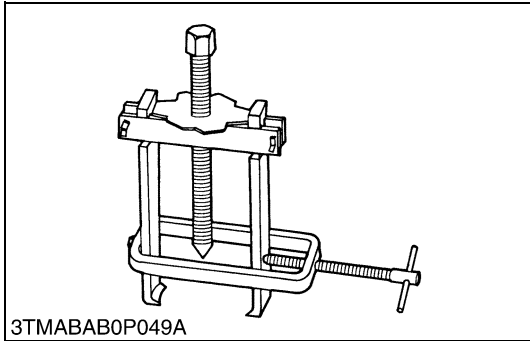

3TMABAB0P049A

Special Use Puller Set

Code No: 07916-09032

Application: Use exclusively for pulling out bearing, gears and other parts with ease.

W1024050

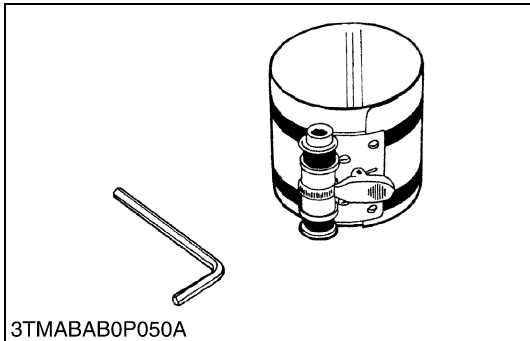

3TMABAB0P050A

Piston Ring Compressor

Code No: 07909-32111

Application: Use exclusively for pushing in the piston with piston rings into the cylinder.

W1024100

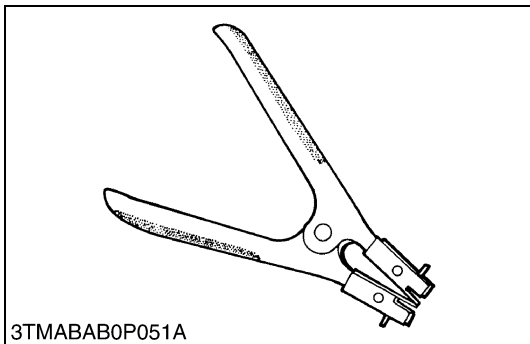

3TMABAB0P051A

Piston Ring Tool

Code No: 07909-32121

Application: Use exclusively for removing or installing the piston ring with ease.

W1024150

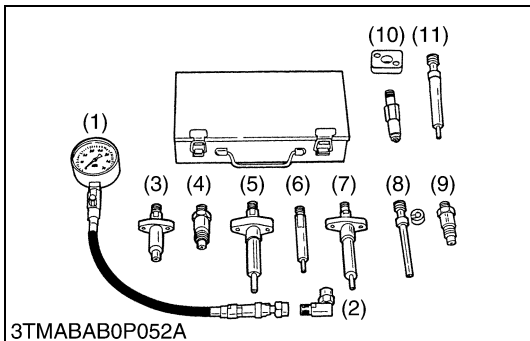

3TMABAB0P052A

Diesel Engine Compression Tester

Code No: 07909-30208 (Assembly) 07909-31251 (G)

07909-30934 (A to F) 07909-31271 (I)

07909-31211 (E and F) 07909-31281 (J)

07909-31231 (H)

Application: Use to measure diesel engine compression and diagnostics of need for major overhaul.

- | | |
|---------------|----------------|
| (1) Gauge | (7) Adaptor F |
| (2) L Joint | (8) Adaptor G |
| (3) Adaptor A | (9) Adaptor H |
| (4) Adaptor B | (10) Adaptor I |
| (5) Adaptor C | (11) Adaptor J |
| (6) Adaptor E | |

W1024200

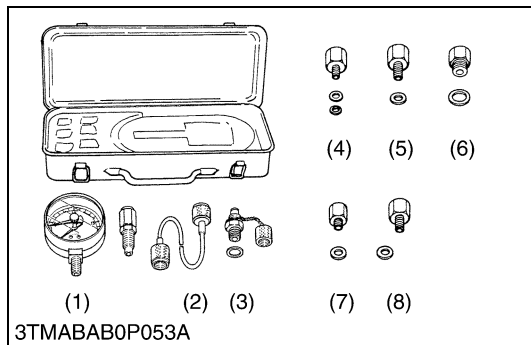

Oil Pressure Tester

Code No: 07916-32032

Application: Use to measure lubricating oil pressure.

- | | |
|--------------------|---------------|
| (1) Gauge | (5) Adaptor 2 |
| (2) Cable | (6) Adaptor 3 |
| (3) Threaded Joint | (7) Adaptor 4 |
| (4) Adaptor 1 | (8) Adaptor 5 |

W1024318

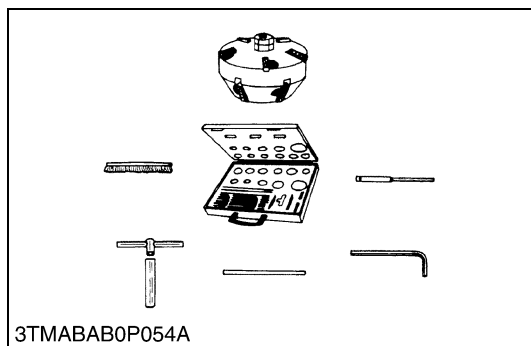

Valve Seat Cutter

Code No: 07909-33102

Application: Use to reseal valves.

Angle: 0.785 rad. (45°)

0.262 rad. (15°)

Diameter: 28.6 mm (1.126 in.) 38.0 mm (1.496 in.)

31.6 mm (1.244 in.) 41.3 mm (1.626 in.)

35.0 mm (1.378 in.) 50.8 mm (2.000 in.)

W1024458

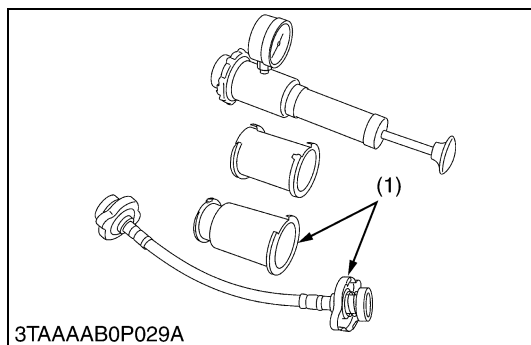

Radiator Tester

Code No: 07909-31551

Application: Use to check of radiator cap pressure, and leaks from cooling system.

Remarks: Adaptor (1) BANZAI Code No. RCT-2A-30S

W1024532

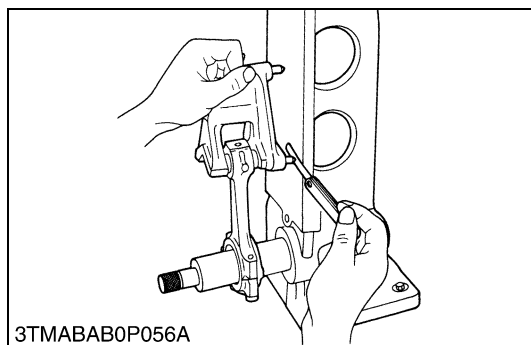

Connecting Rod Alignment Tool

Code No: 07909-31661

Application: Use to check the connecting rod alignment.

Applicable: Connecting rod big end I.D.

range 30 to 75 mm (1.18 to 2.95 in.) dia.

Connecting rod length

65 to 300 mm (2.56 to 11.81 in.)

W1024583

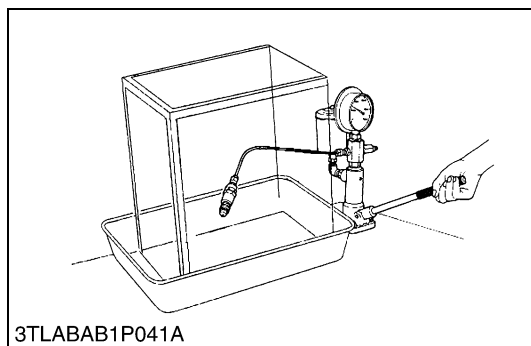

Nozzle Tester

Code No: 07909-31361

Application: Use to check the fuel injection pressure and spray pattern of nozzle.

Measuring: 0 to 50 MPa

range (0 to 500 kgf/cm², 0 to 7000 psi)

W1024653

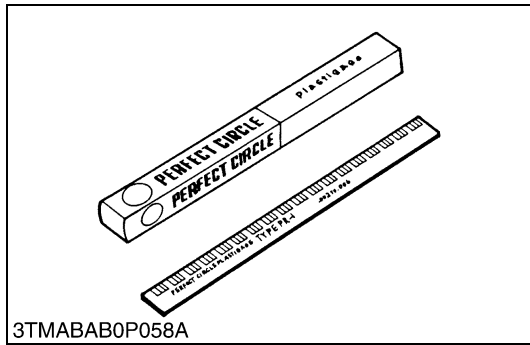

3TMABAB0P058A

Plastigage

Code No: 07909-30241

Application: Use to check the oil clearance between crankshaft and bearing, etc.

Measuring: Green 0.025 to 0.076 mm (0.001 to 0.003 in.)
 range Red 0.051 to 0.152 mm (0.002 to 0.006 in.)
 Blue 0.102 to 0.229 mm (0.004 to 0.009 in.)

W1024719

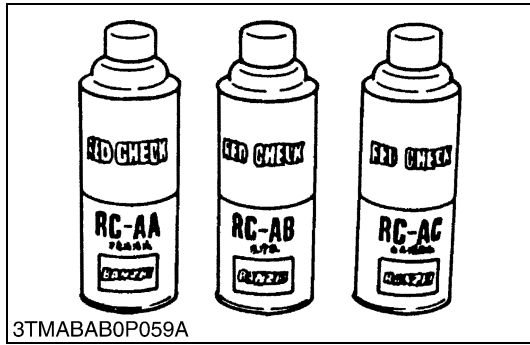

3TMABAB0P059A

Red Check

Code No: 07909-31371

Application: Use to check cracks on cylinder head, cylinder block, etc.

W1024909

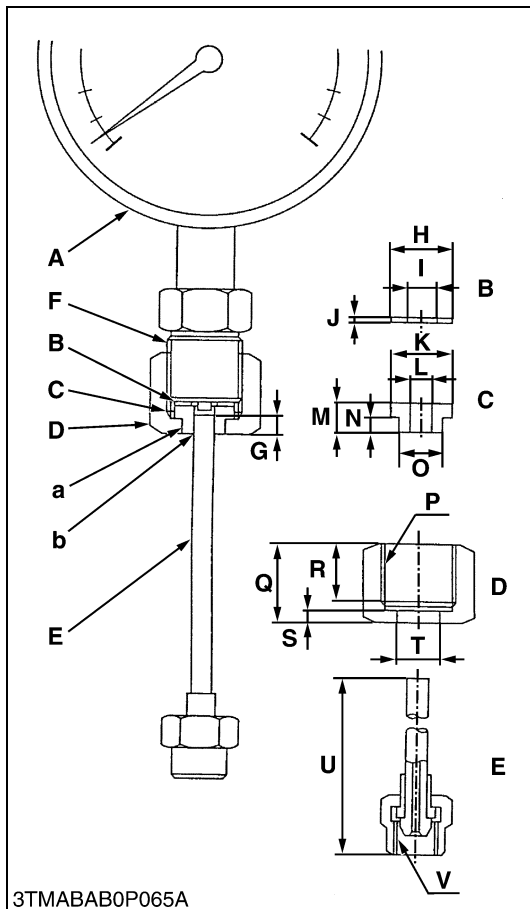

3TMABAB0P065A

Injection Pump Pressure Tester

Application: Use to check fuel tightness of injection pumps.

A	Pressure gauge full scale : More than 29.4 MPa (300 kgf/cm ² , 4267 psi)
B	Copper gasket
C	Flange (Material : Steel)
D	Hex. nut 27 mm (1.06 in.) across the plat
E	Injection pipe
F	PF 1/2
G	5 mm (0.20 in.)
H	17 mm dia. (0.67 in. dia.)
I	8 mm dia. (0.31 in. dia.)
J	1.0 mm (0.039 in.)
K	17 mm dia. (0.67 in. dia.)
L	6.10 to 6.20 mm dia. (0.2402 to 0.2441 in. dia.)
M	8 mm (0.31 in.)
N	4 mm (0.16 in.)
O	11.97 to 11.99 mm dia. (0.4713 to 0.4721 in. dia.)
P	PF 1/2
Q	23 mm (0.91 in.)
R	17 mm (0.67 in.)
S	4 mm (0.16 in.)
T	12.00 to 12.02 mm dia. (0.4724 to 0.4732 in. dia.)
U	100 mm (3.94 in.)
V	M12 x P1.5
a	Adhesive application
b	Fillet welding on the enter circumference

W1025240

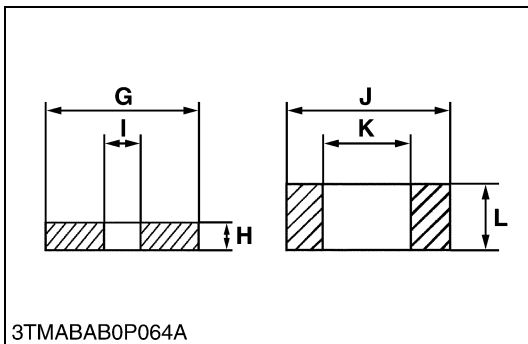
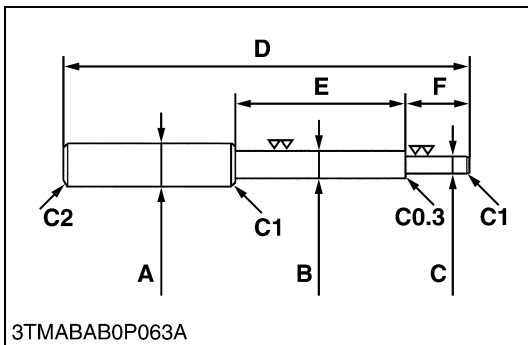

Valve Guide Replacing Tool

Application: Use to press out and press fit the valve guide.

■ **D722-E-BX**

A	20 mm dia. (0.79 in. dia.)
B	9.96 to 9.98 mm dia. (0.3921 to 0.3929 in. dia.)
C	5.5 to 5.7 mm dia. (0.2165 to 0.2244 in. dia.)
D	200 mm (7.87 in.)
E	80 mm (3.15 in.)
F	40 mm (1.58 in.)
G	15 mm (0.59 in.)
H	5 mm (0.197 in.)
I	6.0 to 6.1 mm dia. (0.263 to 0.240 in. dia.)
J	18 mm dia. (0.71 in. dia.)
K	10.6 to 10.7 mm dia. (0.417 to 0.421 in. dia.)
L	7 mm (0.276 in.)
C1	Chamfer 1.0 mm (0.039 in.)
C2	Chamfer 2.0 mm (0.079 in.)
C0.3	Chamfer 0.3 mm (0.012 in.)

■ **D905-E-BX**

A	20 mm dia. (0.79 in. dia.)
B	11.7 to 11.9 mm dia. (0.460 to 0.468 in. dia.)
C	6.5 to 6.6 mm dia. (0.256 to 0.259 in. dia.)
D	225 mm (8.86 in.)
E	70 mm (2.76 in.)
F	45 mm (1.77 in.)
G	25 mm (0.98 in.)
H	5 mm (0.197 in.)
I	6.7 to 7.0 mm dia. (0.263 to 0.275 in. dia.)
J	20 mm dia. (0.787 in. dia.)
K	12.5 to 12.8 mm dia. (0.492 to 0.504 in. dia.)
L	8.9 to 9.1 mm (0.350 to 0.358 in.)
C1	Chamfer 1.0 mm (0.039 in.)
C2	Chamfer 2.0 mm (0.079 in.)
C0.3	Chamfer 0.3 mm (0.012 in.)

W1025017

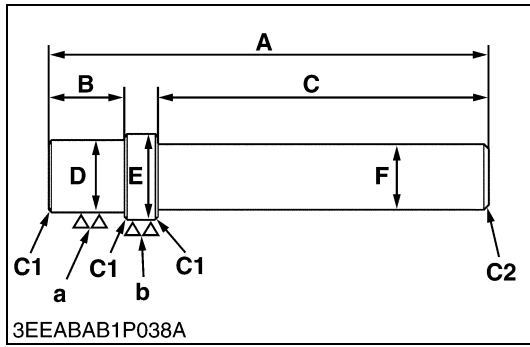

Bushing Replacing Tool

Application: Use to press out and to press fit the bushing.

■ **D722-E-BX**

1. For small end bushing

A	145 mm (5.71 in.)
B	20 mm (0.79 in.)
C	100 mm (3.94 in.)
D	19.90 to 19.95 mm (0.7835 to 0.7854 in.)
E	21.90 to 21.95 mm dia. (0.8622 to 0.8642 in. dia.)
F	25 mm (0.98 in.)
a	6.3 μm (250 μin.)
b	6.3 μm (250 μin.)

2. For idle gear bushing

A	150 mm (5.91 in.)
B	20 mm (0.79 in.)
C	100 mm (3.94 in.)
D	19.90 to 19.95 mm (0.7835 to 0.7854 in.)
E	21.90 to 21.95 mm dia. (0.8622 to 0.8642 in. dia.)
F	25 mm (0.98 in.)
a	6.3 μm (250 μin.)
b	6.3 μm (250 μin.)

■ **D905-E-BX**

1. For small end bushing

A	157 mm (6.1811 in.)
B	24 mm (0.9449 in.)
C	120 mm (4.7244 in.)
D	21.8 to 21.9 mm (0.8583 to 0.8622 in.)
E	24.8 to 24.9 mm dia. (0.9764 to 0.9803 in. dia.)
F	20 mm (0.7874 in.)
a	6.3 μm (250 μin.)
b	6.3 μm (250 μin.)

2. For idle gear bushing

A	196 mm (7.7165 in.)
B	26 mm (1.0236 in.)
C	150 mm (5.9055 in.)
D	25.8 to 25.9 mm (1.0157 to 1.0197 in.)
E	28.8 to 28.9 mm dia. (1.1339 to 1.1378 in. dia.)
F	20 mm (0.7874 in.)
a	6.3 μm (250 μin.)
b	6.3 μm (250 μin.)

W1025500

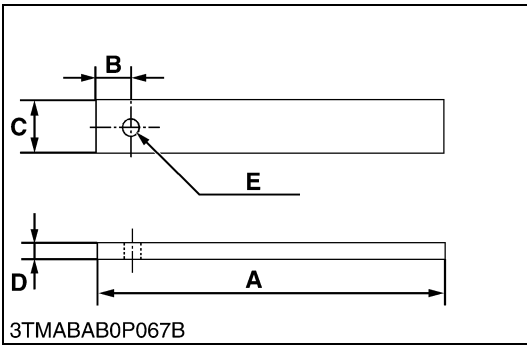

Flywheel Stopper

Application: Use to loosen and tighten the flywheel screw.

A	200 mm (7.87 in.)
B	20 mm (0.79 in.)
C	30 mm (1.18 in.)
D	8 mm (0.31 in.)
E	10 mm dia. (0.39 in. dia.)

W1025948

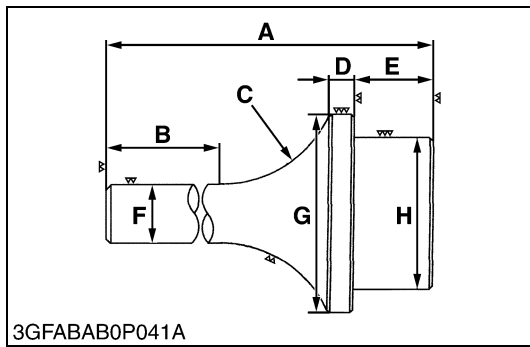

Crankshaft Bearing 1 Replacing Tool

Application: Use to press out and press fit the crankshaft bearing 1.

■ **D722-E-BX**

[Press Out]

A	135 mm (5.31 in.)
B	72 mm (2.83 in.)
C	1.57 rad. (40 °)
D	10 mm (0.39 in.)
E	22 mm (0.87 in.)
F	20 mm dia. (0.79 in. dia.)
G	48.90 to 48.95 mm dia. (1.9251 to 1.9271 in. dia.)
H	43.90 to 43.95 mm dia. (1.7283 to 1.7303 in. dia.)

[Press Fit]

A	130 mm (5.12 in.)
B	72 mm (2.83 in.)
C	1.57 rad. (40 °)
D	9 mm (0.35 in.)
E	24 mm (0.95 in.)
F	20 mm dia. (0.79 in. dia.)
G	68 mm dia. (2.68 in. dia.)
H	39.90 to 39.95 mm dia. (1.5709 to 1.5728 in. dia.)

■ **D905-E-BX**

[Press Out]

A	135 mm (5.31 in.)
B	72 mm (2.83 in.)
C	1.57 rad. (40 °)
D	10 mm (0.39 in.)
E	20 mm (0.79 in.)
F	20 mm dia. (0.79 in. dia.)
G	56.80 to 56.90 mm dia. (2.2362 to 2.2402 in. dia.)
H	51.80 to 51.90 mm dia. (2.0393 to 2.0433 in. dia.)

[Press Fit]

A	130 mm (5.12 in.)
B	72 mm (2.83 in.)
C	1.57 rad. (40 °)
D	9 mm (0.35 in.)
E	24 mm (0.95 in.)
F	20 mm dia. (0.79 in. dia.)
G	68 mm dia. (2.68 in. dia.)
H	47.38 to 47.48 mm dia. (1.865 to 1.869 in. dia.)

W1026139

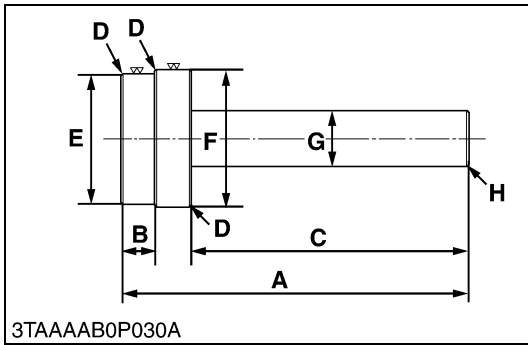

Governor Gear Holder Bushing Replacing Tool

Application: Use to press out and to press fit the governor gear holder bushing.

A	188 mm (7.4 in.)
B	18 mm (0.7 in.)
C	150 mm (5.9 in.)
D	C1 : Chamfer 1.0 mm (0.039 in.)
E	73.9 to 74.0 mm dia. (29.09 to 29.13 in. dia.)
F	69.8 to 69.9 mm (2.748 to 2.751 in. dia.)
G	30 mm dia. (1.181 in. dia.)
H	C2 : Chamfer 2.0 mm (0.079 in.)

W1023337

[2] SPECIAL TOOLS FOR TRACTOR

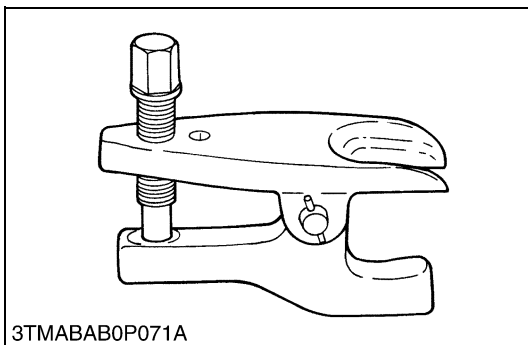

Tie-rod End Lifter

Code No: 07909-39051

Application: Use for removing the tie-rod end with ease.

W1026472

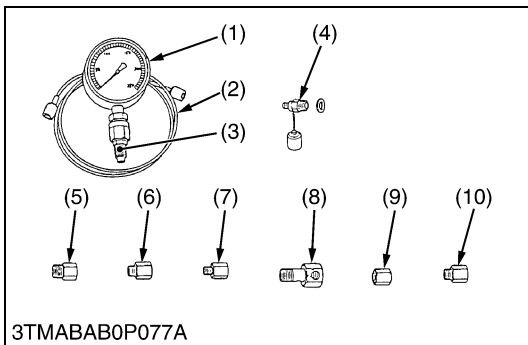

Relief Valve Pressure Tester

Code No: 07916-50045

Application: This allows easy measurement of relief set pressure.

- | | |
|--|---------------------------------------|
| (1) Gauge (07916-50322) | (6) Adaptor C (PS3/8) (07916-50371) |
| (2) Cable (07916-50331) | (7) Adaptor D (PT1/8) (07916-50381) |
| (3) Threaded Joint (07916-50401) | (8) Adaptor E (PS3/8) (07916-50392) |
| (4) Threaded Joint (07916-50341) | (9) Adaptor F (PF1/2) (07916-62601) |
| (5) Adaptor B (M18 x P1.5) (07916-50361) | (10) Adaptor 58 (PT1/4) (07916-52391) |

W1026741

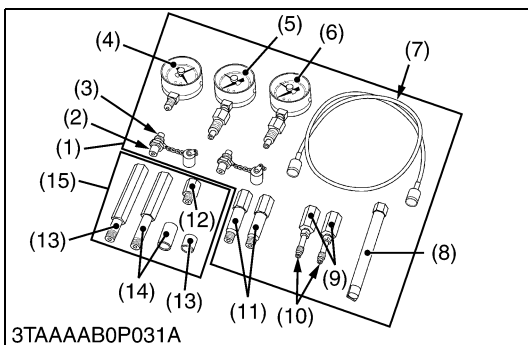

Hydrostatic Transmission Tester and HST Adaptor Set

Code No: 07916-52040 (Hydrostatic Transmission Tester)
07916-53072 (HST Adaptor Set)

Application: This allows easy measurement of hydrostatic transmission pressure.

- | | |
|--|--|
| (1) Hydrostatic Transmission Tester (07916-52040) | (8) Valve Seat Driver (07916-60841) |
| (2) Gasket (04714-00200) | (9) Connector 1 (07916-60811) |
| (3) Connector 3 (07916-51331) | (10) Connector 2 (07916-60821) |
| (4) Vacuum Gauge (07916-51331) | (11) Long Connector (07916-60831) |
| (5) Pressure Gauge (Low Pressure) (07916-51301) | (12) Adaptor 1 (07916-52621) |
| (6) Pressure Gauge (High Pressure) (in Relief Valve Set Pressure Tester) (07916-50321) | (13) Adaptor 2 with Collar (07916-52632) |
| (7) HN Tube (in Relief Valve Set Pressure Tester) (07916-50331) | (14) Adaptor 3 with Collar (07916-52642) |
| | (15) HST Adaptor Set (07916-53072) |

W1023682

9. TIRES

[1] TIRE PRESSURE



CAUTION

- Do not attempt mount a tire. This should be done by a qualified person with the proper equipment.
- Always maintain the correct tire pressure.
Do not inflate tires above the recommended pressure as shown below.

IMPORTANT

- Do not use tires larger than specified.
- When you intend to mount different size of tires from equipped ones, consult your distributor about front drive gear ratio for details.
Excessive wear of tires may occur due to improper gear ratio.

	Tire sizes	Inflation pressure
Front	18 × 8.50 – 8 Turf	150 kPa (1.5 kgf/cm ² , 22 psi)
	18 × 8.50 – 8 Bar	150 kPa (1.5 kgf/cm ² , 22 psi)
Rear	26 × 12.00 – 12 Turf	140 kPa (1.4 kgf/cm ² , 20 psi)
	26 × 12.00 – 12 Bar	140 kPa (1.4 kgf/cm ² , 20 psi)

Though the tire pressure is factory-set to the prescribed level, it naturally drops slowly in the course of time. Thus, check it everyday and inflate as necessary.

NOTE

- Maintain the maximum pressure in front tires, if using a front loader or when equipped with a full load of front weights.

[2] TREAD

The tread can not be adjusted.

IMPORTANT

- Do not turn discs to obtain wider tread.
- Always attach tires as shown in the drawing.
- If not attached as illustrated, transmission parts may be damaged.

NOTE

- Use the tapered bolts for wheels with beveled or tapered holes.

Front	Rear
18 × 8.50 – 8 Turf, Bar	26 × 12.00 – 12 Turf, Bar
<p>3TAAAA0P032A</p>	<p>3TAAAA0P033A</p>

A : 910 mm (35.8 in.)

B : 820 mm (32.2 in.)

[3] TIRE LIQUID INJECTION

Auxiliary weights can be used to increase traction force for plowing in fields or clayey grounds.

Another way is to inject water or another liquid, such as a calcium chloride solution in the tires. Water must not be used in winter since it freezes at 0 °C (32 °F). The calcium chloride solution will not freeze and moreover, affords higher effect than water since its specific gravity is higher than that of water by about 20 %. Below is an explanation of calcium chloride solution injection.

■ IMPORTANT

- Do not fill the front tires with liquid.

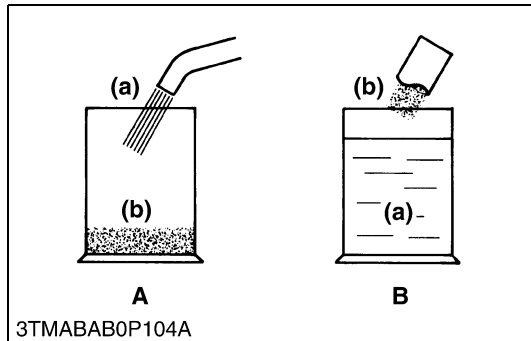

Preparation of Calcium Chloride Solution

⚠ CAUTION

- When making a calcium chloride solution, do not pour water over calcium chloride since this results in chemical reaction which will cause high temperature. Instead add a small amount of calcium chloride to the water at a time until the desired solution is achieved.

Freezing temp.	Weight of CaCl ₂ to be dissolved in 100 L (26.5 U.S.gals., 22.0 Imp.gals.) of water
-5 °C (23 °F)	12 kg (26.4 lbs)
-10 °C (14 °F)	21 kg (46.3 lbs)
-15 °C (5 °F)	28 kg (61.7 lbs)
-20 °C (-4 °F)	34 kg (75.0 lbs)
-25 °C (-13 °F)	40 kg (88.2 lbs)
-33 °C (-22 °F)	44 kg (97.0 lbs)
-35 °C (-31 °F)	49 kg (108 lbs)
-40 °C (-40 °F)	52 kg (114.6 lbs)
-45 °C (-49 °F)	56 kg (123.5 lbs)
-50 °C (-58 °F)	61 kg (134.5 lbs)

(a) Water

(b) CaCl₂ (Calcium Chloride)

W1033083

Attaching Injector

1. Lift the rear tires off the ground.
2. Turn the tire so that the air valve is at the top.
3. Remove the air valve, and attach the injector. (Code No. 07916-52511)

(1) Injector

(2) Hose

W1033331

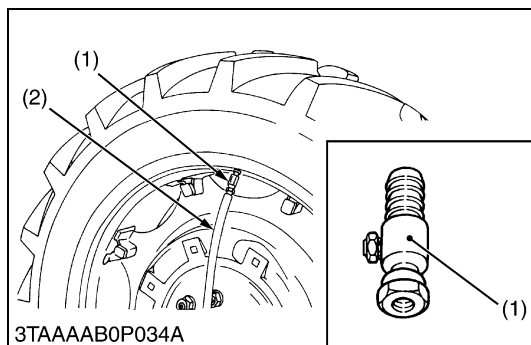

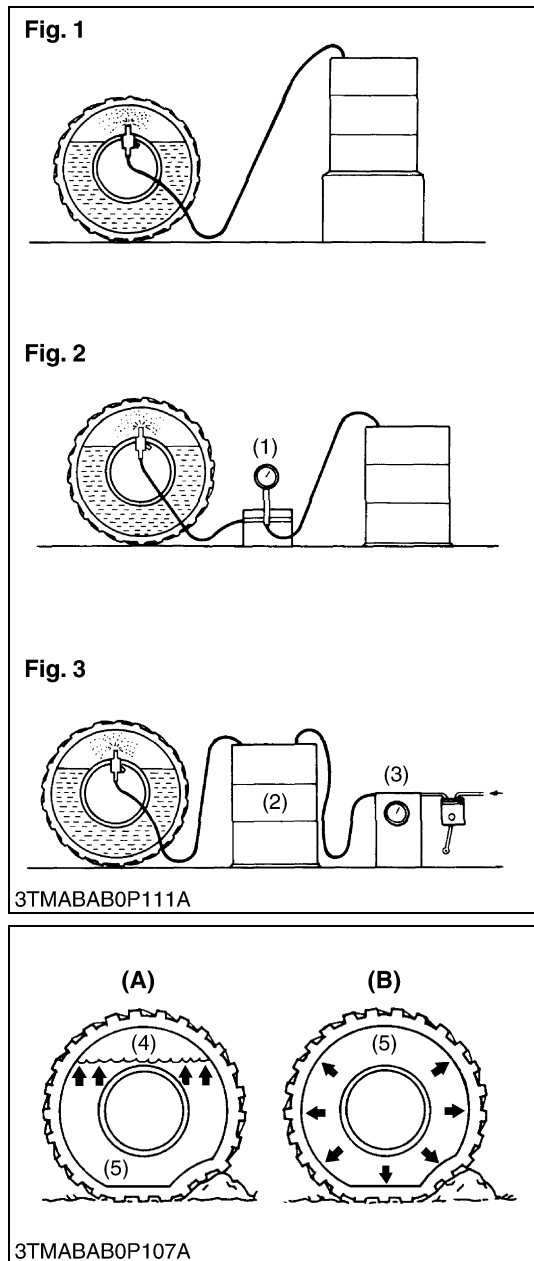

Injection

⚠ CAUTION

- When a calcium chloride solution is used, cool it before pouring it into the tire.
- Do not fill tires with water or solution more than 75 % of full capacity (to the valve stem level).
- To avoid damage of transmission, do not use rear wheel weights and liquid ballast at the same time.

The following four ways can be used to inject water or a calcium chloride solution into tires.

1. Gravity injection (Fig. 1)
2. Pump injection (Fig. 2)
3. Pressure tank injection (Fig. 3)
4. Injection directly from tap (only when water is being used).

■ NOTE

- Once injection is completed, reset the air valve, and pump air into the tire to the specified pressure.

Weight of Calcium Chloride Solution Filling 75 % of Full Capacity of a Tire

Tire sizes	26 × 12.00 – 12
Slush free at –10 °C (14 °F) Solid at –30 °C (–22 °F) [Approx. 1 kg (2 lbs.) CaCl ₂ per 4 L (1 gal.) of water]	45 kg (99 lbs)
Slush free at –24 °C (–11 °F) Solid at –47 °C (–53 °F) [Approx. 1.5 kg (3.5 lbs.) CaCl ₂ per 4 L (1 gal.) of water]	50 kg (110 lbs)
Slush free at –47 °C (–53 °F) Solid at –52 °C (–62 °F) [Approx. 2.25 kg (5 lbs.) CaCl ₂ per 4 L (1 gal.) of water]	56 kg (123 lbs)

- (1) Pump
- (2) Pressure Tank
- (3) Compressor
- (4) Air
- (5) Water

- (A) Correct : 75 %
Air Compresses Like A Cushion**
- (B) Incorrect : 100 % Full
Water Can Not Be Compressed**

W1033435

10. IMPLEMENT LIMITATIONS

The KUBOTA Tractor has been thoroughly tested for proper performance with implements sold or approved by KUBOTA. Use with implements which are not sold or approved by KUBOTA and which exceed the maximum specifications listed below, or which are otherwise unfit for use with the KUBOTA Tractor may result in malfunctions or failures of the tractor, damage to other property and injury to the operator or others. [Any malfunctions or failures of the tractor resulting from use with improper implements are not covered by the warranty.]

	Tread (max. width) with farm tires		Lower link end max. loading weight W_0
	Front	Rear	
BX1800	910 mm (35.8 in.)	820 mm (32.2 in.)	550 kg (1213 lbs.)
BX2200			

	Actual figures		
	Implement weight W_1 and / or size	Max. Drawbar Load W_2	Trailer loading weight W_3 Max. capacity
BX1800	As in the following list (Shown on the next page)	250 kg (551 lbs)	800 kg (1764 lbs)
BX2200			

Lower link end max. loading weightThe max. allowable load which can be put on the lower link end : W_0
 Implement weight.....The implement's weight which can be put on the lower link : W_1
 Max. drawbar load W_2
 Trailer loading weightThe max. loading weight for trailer (without trailer's weight) : W_3

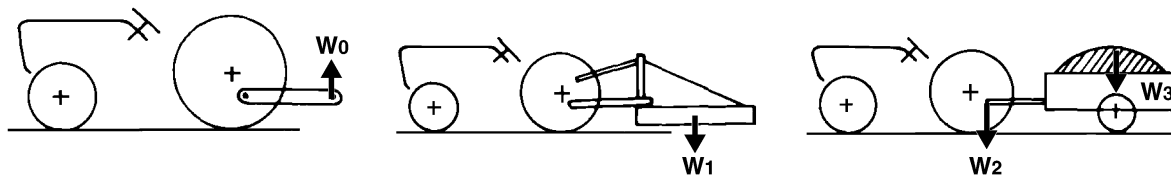

3TMABAB0P109A

NOTE

- Implement size may vary depending on soil operating conditions.

Implement		Remarks	BX1800	BX2200
Mower	Mid-Mount	Max. Cutting Width	1524 mm (60 in.)	
		Max. Weight	140 kg (309 lbs)	
	Rotary-Cutter (1 Blade)	Max. Cutting Width	1067 mm (42 in.)	
		Max. Weight	140 kg (309 lbs)	
	Rear-Mount (2 or 3 Blade)	Max. Cutting Width	1524 mm (60 in.)	
		Max. Weight	140 kg (309 lbs)	
Flail Mower	Max. Cutting Width	1067 mm (42 in.)		
Sickle Bar	Max. Cutting Width	1219 mm (48 in.)		
Rotary Tiller		Max. Tilling Width	1067 mm (42 in.)	
		Max. Weight	170 kg (375 lbs)	
Bottom Plow		Max. Size	305 mm (12 in.) × 1	356 mm (14 in.) × 1
Disc Plow		Max. Size	559 mm (22 in.) × 1	
Cultivator		Max. Size	1219 mm (48 in.) 1 Row	
Disc Harrow		Max. Harrowing Width	1219 mm (48 in.)	1372 mm (54 in.)
		Max. Weight	120 kg (265 lbs)	140 kg (309 lbs)
Sprayer		Max. Tank Capacity	150 L (40 U.S.gals.)	
Front Blade		Max. Cutting Width	1372 mm (54 in.)	1524 mm (60 in.)
		Sub Frame	Necessary	Necessary
Rear Blade		Max. Cutting Width	1524 mm (60 in.)	
		Max. Weight	160 kg (353 lbs)	
Front Loader		Max. Lifting Capacity	210 kg (463 lbs)	
		Max. Width	1219 mm (48 in.)	
		Sub Frame	Necessary	
Box Blade		Max. Cutting Width	1067 mm (42 in.)	
		Max. Weight	170 kg (375 lbs)	
Snow Blower (Front)		Max. Working Width	1270 mm (50 in.)	
		Max. Weight	160 kg (353 lbs)	
		Sub Frame	Necessary	
Post Hole Digger		Digging Depth	1143 mm (45 in.)	
Rotary Broom		Cleaning Width	1194 mm (47 in.)	
Trailer		Max. Load Capacity	800 kg (1764 lbs)	

NOTE

- Implement size may vary depending on soil operating conditions.

W1012736

1 ENGINE

MECHANISM

CONTENTS

1. ENGINE BODY	1-M1
[1] CYLINDER BLOCK.....	1-M1
[2] CYLINDER HEAD.....	1-M2
[3] CRANKSHAFT.....	1-M3
[4] PISTON AND PISTON RINGS	1-M3
[5] CONNECTING ROD.....	1-M4
[6] CAMSHAFT	1-M4
[7] FUEL CAMSHAFT	1-M5
[8] ROCKER ARM.....	1-M5
[9] INTAKE AND EXHAUST VALVE	1-M6
[10] VALVE TIMING.....	1-M6
[11] FLYWHEEL.....	1-M6
[12] AIR CLEANER	1-M7
[13] MUFFLER	1-M7
2. LUBRICATING SYSTEM	1-M8
[1] OIL PUMP.....	1-M9
[2] RELIEF VALVE.....	1-M10
[3] OIL FILTER CARTRIDGE.....	1-M10
[4] OIL PRESSURE SWITCH	1-M11
3. COOLING SYSTEM.....	1-M12
[1] WATER PUMP.....	1-M12
[2] THERMOSTAT	1-M13
[3] RADIATOR.....	1-M13
[4] RADIATOR CAP	1-M14
4. FUEL SYSTEM	1-M15
[1] FUEL LINE.....	1-M15
[2] FUEL FILTER.....	1-M15
[3] FUEL PUMP.....	1-M16
[4] INJECTION PUMP.....	1-M16
[5] INJECTION NOZZLE.....	1-M19
[6] GOVERNOR	1-M20
(1) D722-E-BX.....	1-M20
(2) D905-E-BX.....	1-M21

1. ENGINE BODY

[1] CYLINDER BLOCK

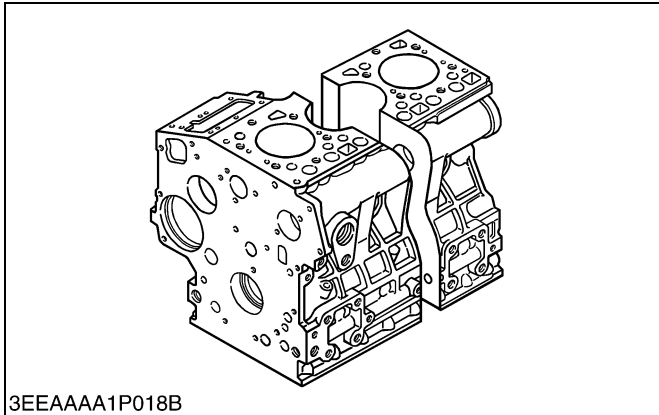

3EEAAA1P018B

The engine has a high durability tunnel-type cylinder block in which the crank bearing component is a constructed body.

Furthermore, liner less type, allow effective cooling, less distortion, and greater wear-resistance.

The noise level is reduced to a minimum because each cylinder has its own chamber.

W1012651

[2] CYLINDER HEAD

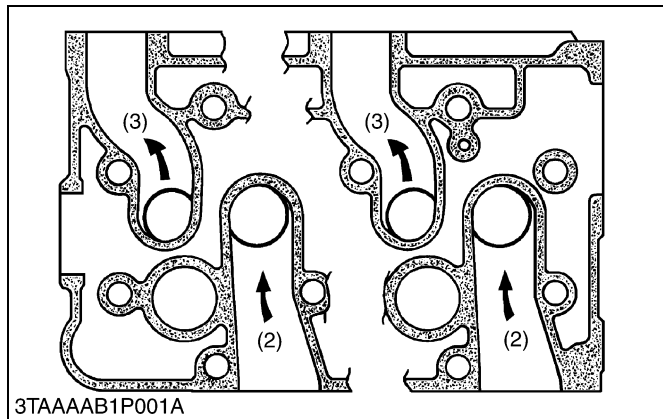

The cross-flow type intake / exhaust ports in this engine have their openings at both sides of the cylinder head. Because overlaps of intake / exhaust ports are smaller than in ports of other types which have openings on one side, the suction air can be protected from being heated and expanded by heated exhaust air. The cool, high density suction air has high volume efficiency and raises the power of the engine. Furthermore, distortion of the cylinder head by heated exhaust gas is reduced because intake ports are arranged alternately.

The combustion chamber is of KUBOTA's exclusive E-TVCS combustion chamber type. Suction air is shirled to be mixed effectively with fuel, prompting combustion and reducing fuel consumption.

In the combustion chamber are installed throttle type injection nozzle and rapid heating sheathed type glow plug. This glow plug assures easier than ever engine starts even at -15°C (5°F).

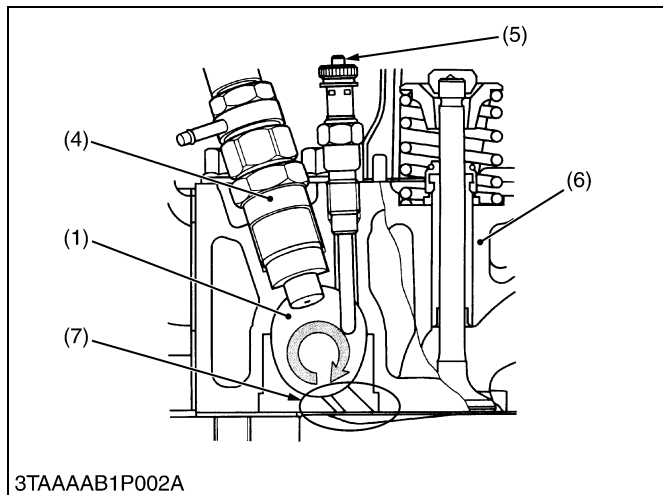

- (1) Combustion Chamber
- (2) Intake Port
- (3) Exhaust Port
- (4) Nozzle Assembly
- (5) Glow Plug
- (6) Cylinder Head
- (7) Depression
- (8) Compressed Air

(A) Connect to Combustion Chamber

W1012704

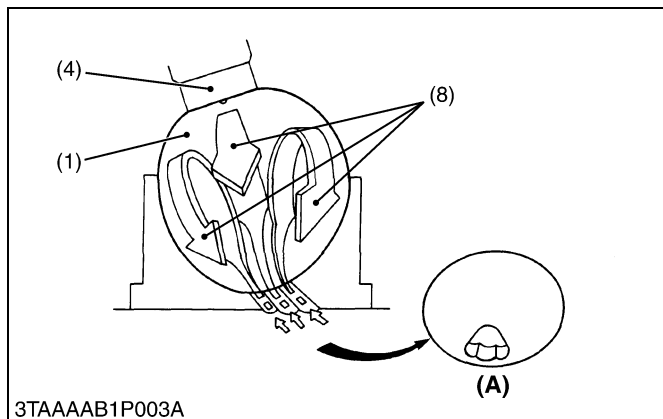

[3] CRANKSHAFT

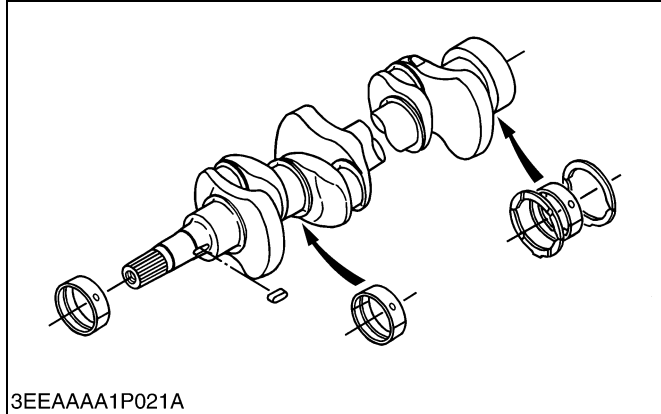

The crankshaft with the connecting rod converts the reciprocating motion of the piston into the rotating motion.

The crankshaft is made of tough special alloy steel, and the journals, pins and oil seal sliding portions are induction hardened to increase the hardness for higher wear resistance.

The front journal is supported by a solid type bearing, the intermediate journal by a split type, and the rear journal by a split type with thrust bearings.

The crankshaft is provided with an oil gallery, through which engine oil is fed to the crankpin portion, and lubricate it.

W1012847

[4] PISTON AND PISTON RINGS

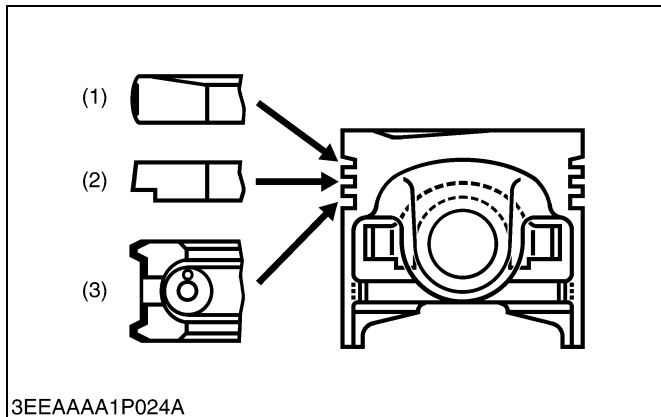

The piston has a slightly oval shape when cold (in consideration of thermal expansion) and a concave head.

Three rings are installed in grooves in the piston.

The top ring (1) is a keystone type, which can stand against heavy loads, and the barrel face on the ring fits well to the cylinder wall.

The second ring (2) is an undercut type, which effectively prevents the oil from being carried up.

The oil ring (3) has chamfered contact faces and an expander ring, which increase the pressure of the oil ring against the cylinder wall.

Several grooves are cut on the top land to help heat dissipate and to prevent scuffing.

- (1) Top Ring
- (2) Second Ring
- (3) Oil Ring
- (4) Depression
- (5) Valve Recess

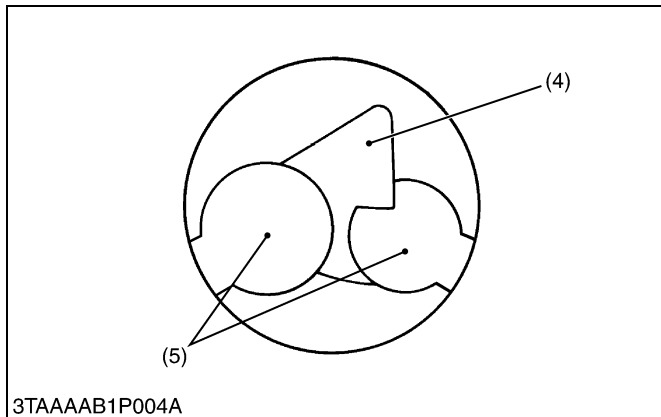

W1013119

[5] CONNECTING ROD

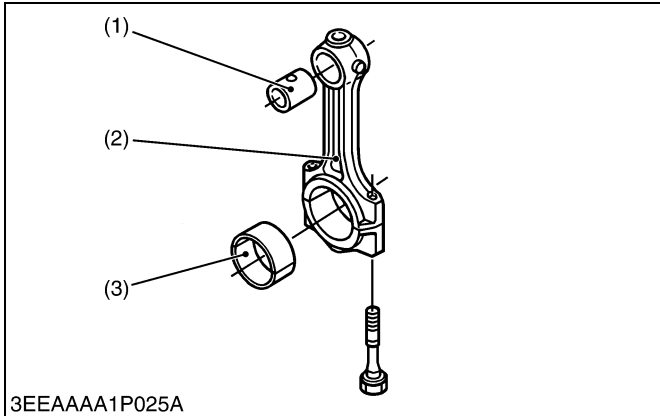

The connecting rod (2) is used to connect the piston with the crankshaft.

The big end of the connecting rod has a crankpin bearing (3) (split type) and the small end has a small end bushing (1) (solid type).

- | | |
|-----------------------|----------------------|
| (1) Small End Bushing | (3) Crankpin Bearing |
| (2) Connecting Rod | |

W1013316

[6] CAMSHAFT

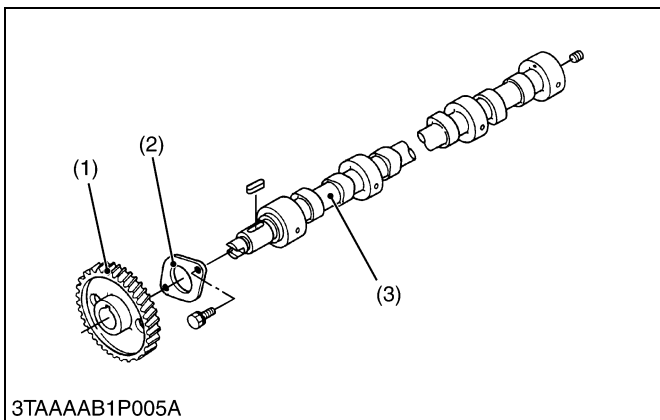

The camshaft (3) is made of special cast iron, and the journal and cam sections are chilled to resist wear.

The journal sections are force-lubricated.

- | | |
|----------------------|--------------|
| (1) Cam Gear | (3) Camshaft |
| (2) Camshaft Stopper | |

W1013582

[7] FUEL CAMSHAFT

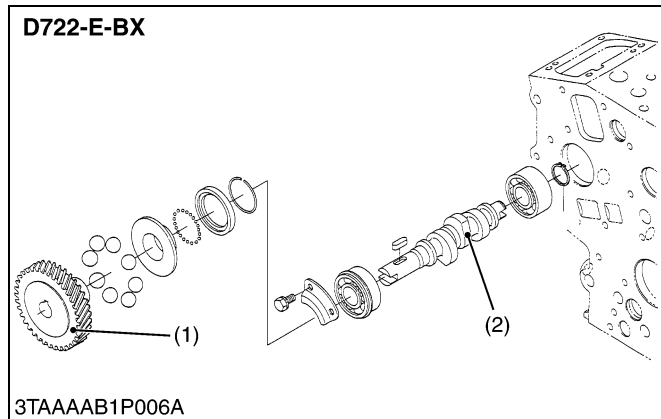

The fuel camshaft (2) controls the reciprocating movement of the injection pump.

The fuel camshaft is made of carbon steel and the cam sections are quenched and tempered to provide greater wear resistance.

- (1) Injection Pump gear
- (2) Fuel Camshaft

W1013666

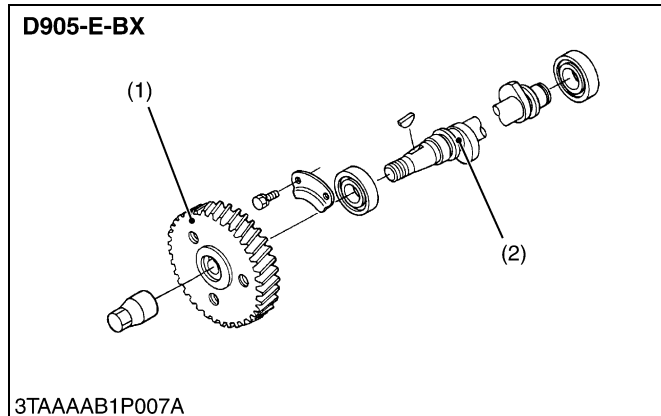

[8] ROCKER ARM

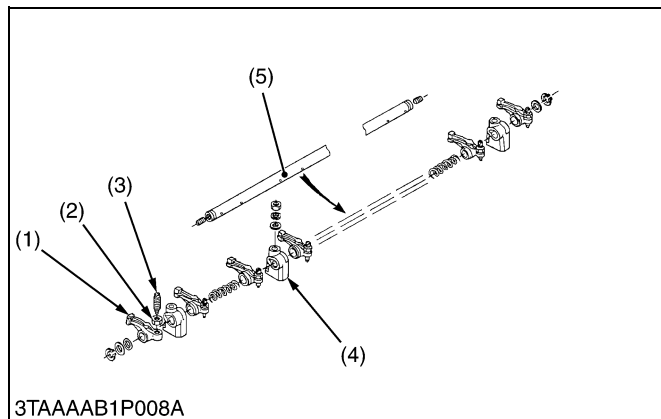

The rocker arm assembly includes the rocker arms (1), rocker arm brackets (4) and rocker arm shaft (5), and converts the reciprocating movement of the push rods to an open / close movement of the intake and exhaust valves.

Lubricating oil pressurized through the bracket to the rocker arm shaft, which serves as a fulcrum so that the rocker arm and the entire system are lubricated sufficiently.

- (1) Rocker Arm
- (2) Lock Nut
- (3) Adjusting Screw
- (4) Rocker Arm Bracket
- (5) Rocker Arm Shaft

W1013940

[9] INTAKE AND EXHAUST VALVE

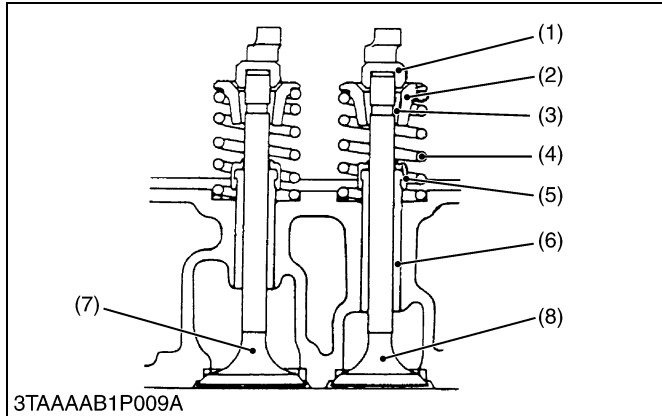

The intake and exhaust valves (7), (8) and their guides (6) are different from each other. Other parts, such as valve springs (4), valve spring retainers (2), valve spring collets (3), valve stem seals (5) and valve caps (1) are the same for both the inlet and exhaust valves. All contact or sliding parts are quenched and tempered to resist wear.

- (1) Valve Cap
- (2) Valve Spring Retainer
- (3) Valve Spring Collet
- (4) Valve Spring
- (5) Valve Stem Seal
- (6) Valve Guide
- (7) Intake Valve
- (8) Exhaust Valve

W1014029

[10] VALVE TIMING

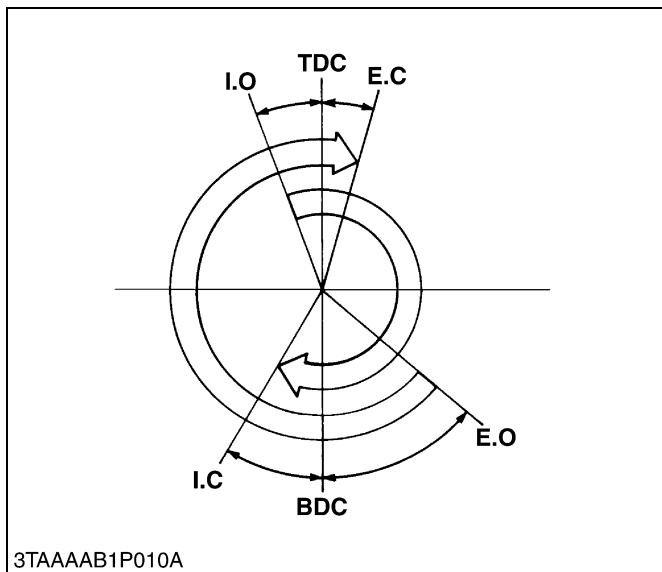

The valve opening and closing timing is extremely important for effectively intaking air into the cylinder and sufficiently exhaust gas. An appropriate timing can be obtained by aligning the alignment marks on the crank gear and cam gear.

[D722-E-BX]

Inlet valve open (I.O.)	0.35 rad. (20 °) before T.D.C.
Inlet valve close (I.C.)	0.79 rad. (45 °) after B.D.C.
Exhaust valve open (E.O.)	0.89 rad. (50 °) before B.D.C.
Exhaust valve close (E.C.)	0.26 rad. (15 °) after T.D.C.

[D905-E-BX]

Inlet valve open (I.O.)	0.24 rad. (14 °) before T.D.C.
Inlet valve close (I.C.)	0.52 rad. (30 °) after B.D.C.
Exhaust valve open (E.O.)	0.96 rad. (55 °) before B.D.C.
Exhaust valve close (E.C.)	0.24 rad. (14 °) after T.D.C.

W1014364

[11] FLYWHEEL

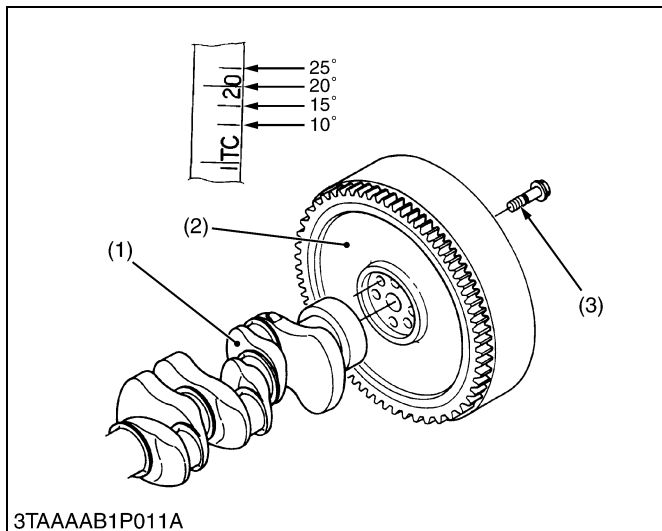

The flywheel is installed on the rear end of the crankshaft. Its inertia keeps the flywheel turning at a constant speed, while the crankshaft tends to speed up during the power stroke and to slow down during other strokes.

The flywheel has a ring gear, which mesh with the drive pinion of the starter.

The flywheel has also marks **TC** and fuel injection timing lines on its outer rim. The lines of fuel injection timing shows the fuel injection timing and the mark **TC** shows the piston's top dead center, when they are aligned with the alignment mark on the rear end plate.

On the circumference of the flywheel are stamped the top dead center (1TC) mark for the 1st cylinder and four lines indicating every 0.087 rad. (5 °) of crank angle from 0.175 rad. (10 °) to 0.436 rad. (25 °) before mark 1TC.

- (1) Crankshaft
- (2) Flywheel
- (3) Flywheel Screw

W1014555

[12] AIR CLEANER

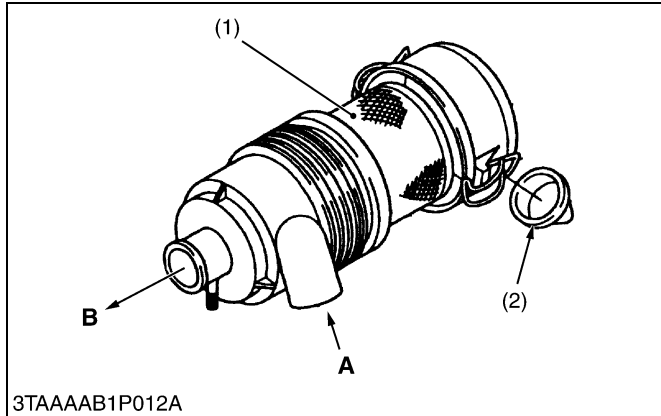

The air cleaner is of a dry type with evacuator valve (2) for easy maintenance. The dust, while circulating in the air flow, is absorbed by the element (1) and thus prevented from entering the engine.

- (1) Air Cleaner Element
 - (2) Evacuator Valve
- A : From Air Inlet**
B : Into Cylinder

W1014694

[13] MUFFLER

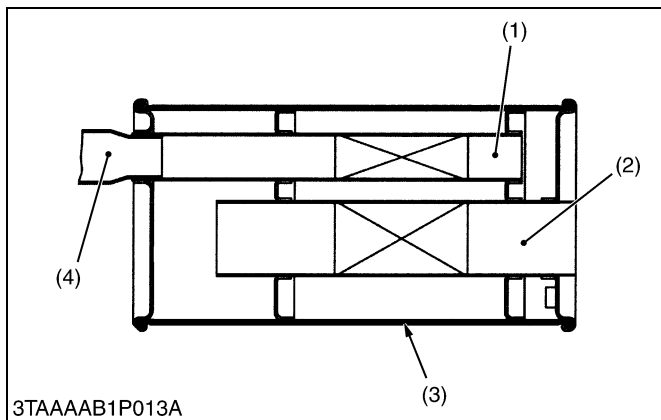

The muffler consists of an inner pipe 1 (1) and 2 (2) with a series of holes and outer tube (3).

The exhaust noises are absorbed and dumped, while the gas pass through the series of holes on the inner pipe (1), (2).

- (1) Inner Pipe 1
- (2) Inner Pipe 2
- (3) Outer Tube
- (4) Exhaust Pipe

W1014904

2. LUBRICATING SYSTEM

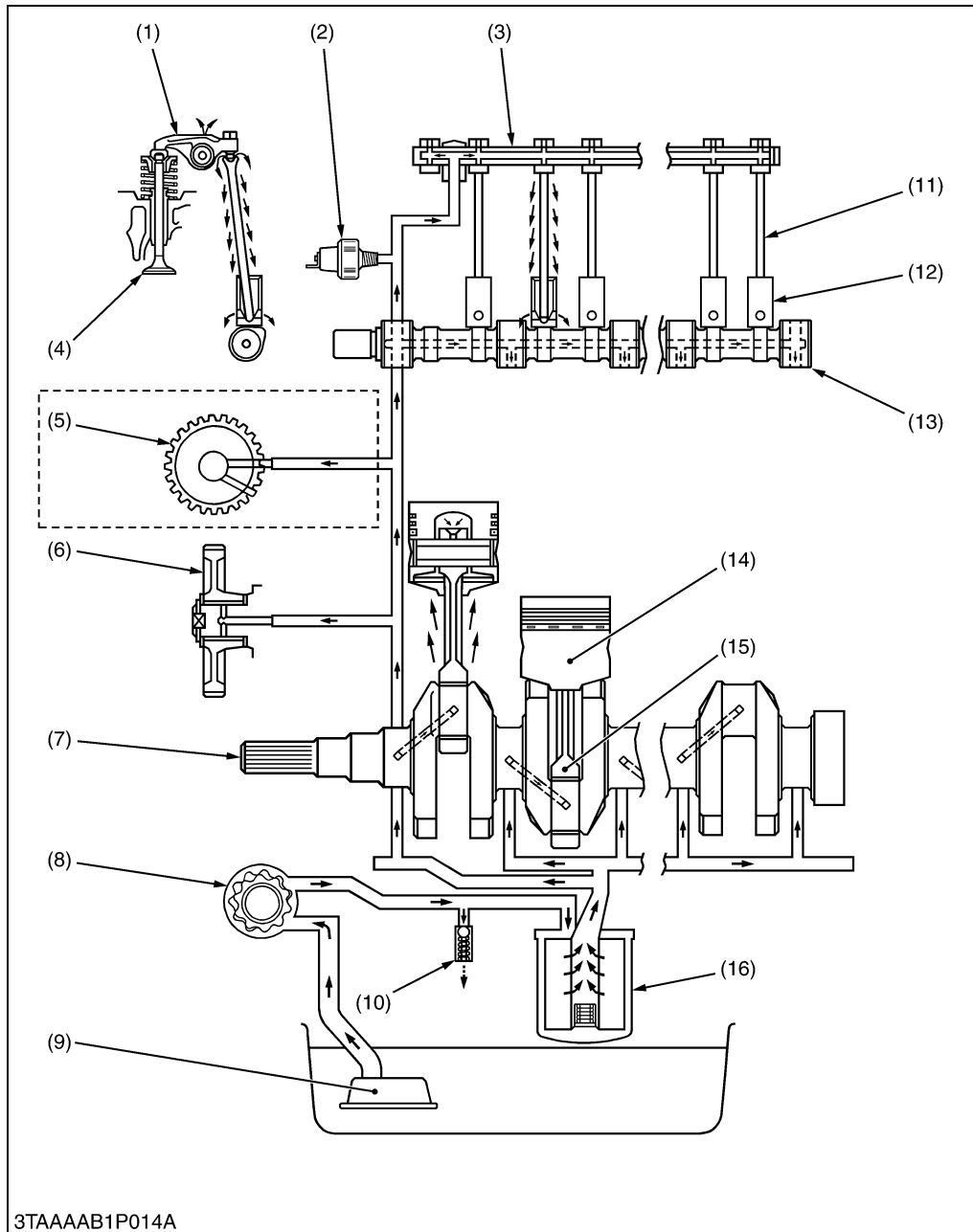

- (1) Rocker Arm
- (2) Oil Pressure Switch
- (3) Rocker Arm Shaft
- (4) Valve
- (5) Governor Shaft Gear (D905 Only)
- (6) Idle Gear
- (7) Crankshaft
- (8) Oil Pump
- (9) Oil Strainer
- (10) Relief Valve
- (11) Push Rod
- (12) Tappet
- (13) Camshaft
- (14) Piston
- (15) Connecting Rod
- (16) Oil Filter Cartridge

W1015010

3TAAAAB1P014A

This engine's lubricating system consists of oil strainer (9), oil pump (8), relief valve (10), oil filter cartridge (16) and oil pressure switch (2).

The oil pump sucks lubricating oil from the oil pan through the oil strainer and the oil flows down to the filter cartridge, where it is further filtered. Then the oil is forced to crankshaft (7), connecting rods (15), idle gear (6), governor shaft gear (5), camshaft (13) and rocker arm shaft (3) to lubricate each part.

Some part of oil, splashed by the crankshaft or leaking and dropping from gaps of each part, lubricates these parts: pistons (14), cylinders, small ends of connecting rods, tappets (12), push rods (11), inlet and exhaust valves (4) and timing gears.

[1] OIL PUMP

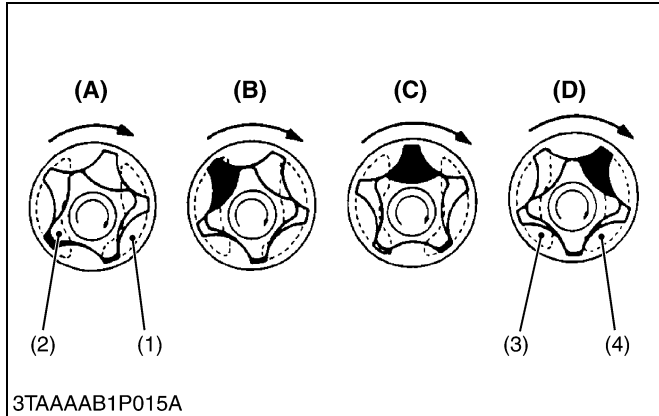

■ D722-E-BX

The oil pump is a trochoid pump.

Inside the pump body, the 4 lobe inner rotor (2) is eccentrically engaged with the 5 lobe outer rotor (1). The inner rotor is driven by the crankshaft, which in turn rotate the outer rotor.

When the inner rotor rotates, the outer rotor also rotates in the same direction. The two rotors have differences in lobe number and center, which generates space between lobes as shown in the figure.

At position (A), there is little space between lobes in the inlet port. As the rotor rotates towards position (B), the space between the lobes becomes larger, creating a negative pressure which sucks in oil.

Outside the inlet port, as shown in position (C), the space between the lobes becomes gradually smaller, and oil pressure increases. At position (D), oil is discharged from the outlet port.

- | | |
|-----------------|-----------------|
| (1) Outer Rotor | (3) Inlet Port |
| (2) Inner Rotor | (4) Outlet Port |

W1015262

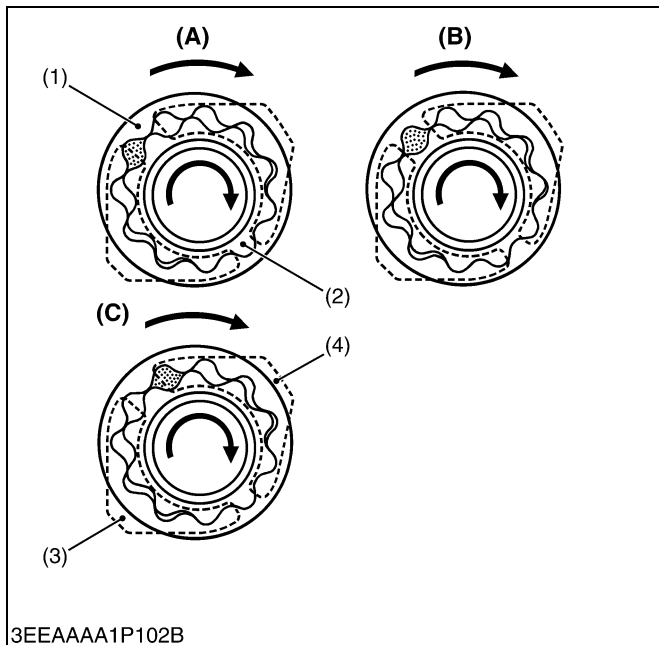

■ D905-E-BX

The oil pump is a trochoid pump.

Inside the pump body, the 10 lobe inner rotor (2) is eccentrically engaged with the 11 lobe outer rotor (1). The inner rotor is driven by the crankshaft, which in turn rotate the outer rotor.

When the inner rotor rotates, the outer rotor also rotates in the same direction. The two rotors have differences in lobe number and center, which generates space between lobes as shown in the figure.

At position (A), there is little space between lobes in the inlet port (3). As the rotors rotate, the space between the lobes becomes larger, creating a negative pressure which sucks in oil.

When the rotors rotate to position (B), the port to which the space leads is changed from inlet to outlet.

At position (C), the space decreases and sucked oil is discharged from the outlet port (4).

- | | |
|-----------------|-----------------|
| (1) Outer Rotor | (3) Inlet Port |
| (2) Inner Rotor | (4) Outlet Port |

W1015536

[2] RELIEF VALVE

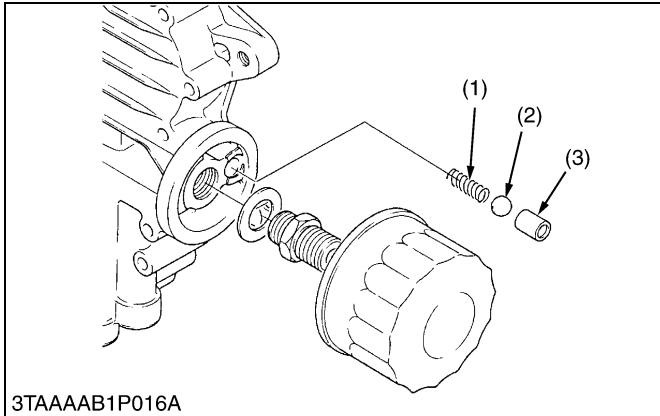

The relief valve prevents the damage of the lubricating system due to high oil pressure. This relief valve is a ball type direct acting relief valve, and is best suited for low pressures.

When oil pressure exceeds the upper limit, the ball (2) is pushed back by the oil pressure and the oil escapes.

- (1) Spring
- (2) Ball
- (3) Valve Seat

W1015673

[3] OIL FILTER CARTRIDGE

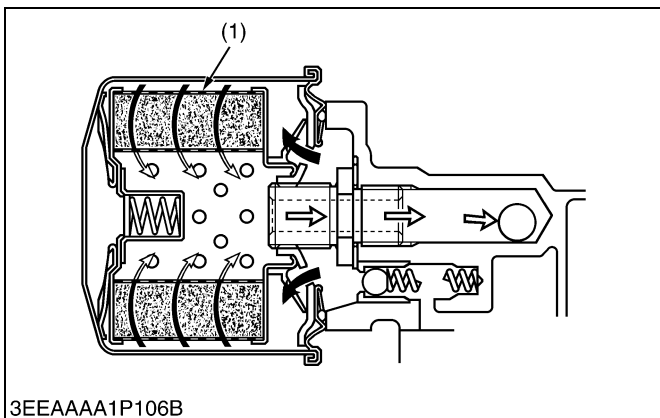

Impurities in engine oil can cause to wear and seize components as well as impairing the physical and chemical properties of the oil itself. Impurities contained in force-fed engine oil are absorbed on the filter paper for removal as they pass through the filter element (1).

When the filter element is clogged and the oil pressure in inlet line builds up by 98 kPa (1.0 kgf/cm², 14 psi) more than the outlet line, the bypass valve (2) opens and the oil flows from inlet to outlet bypassing the filter element.

- (1) Filter Element
- (2) Bypass Valve

W1015892

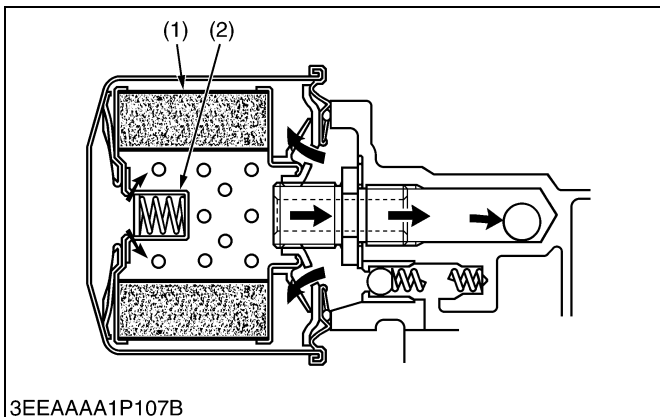

3EEAAA1P107B

[4] OIL PRESSURE SWITCH

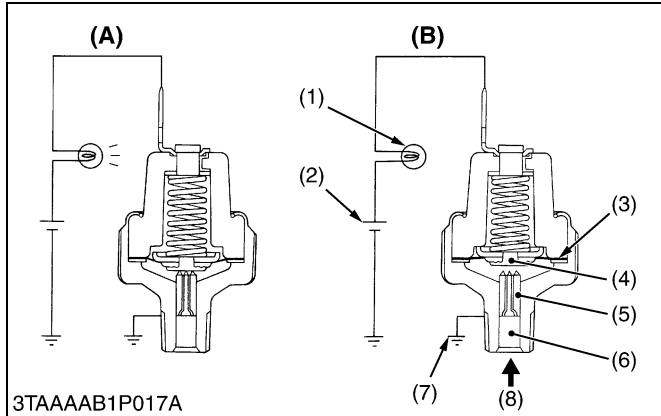

The oil pressure switch is mounted on the cylinder block, to warn the operator that the lubricating oil pressure is poor.

If the oil pressure falls below the specified value, the oil warning lamp will light up, warning the operator. In this case, stop the engine immediately and check the cause of pressure drop.

- (1) Warning Lamp
- (2) Battery
- (3) Rubber Gasket
- (4) Contact Rivet
- (5) Contact
- (6) Oil Passage
- (7) Cylinder Block
- (8) Oil

(A) At Lower Oil Pressure
(49 kPa, 0.5 kgf/cm², 7 psi
or less)

(B) At Proper Oil Pressure

W1015964

3. COOLING SYSTEM

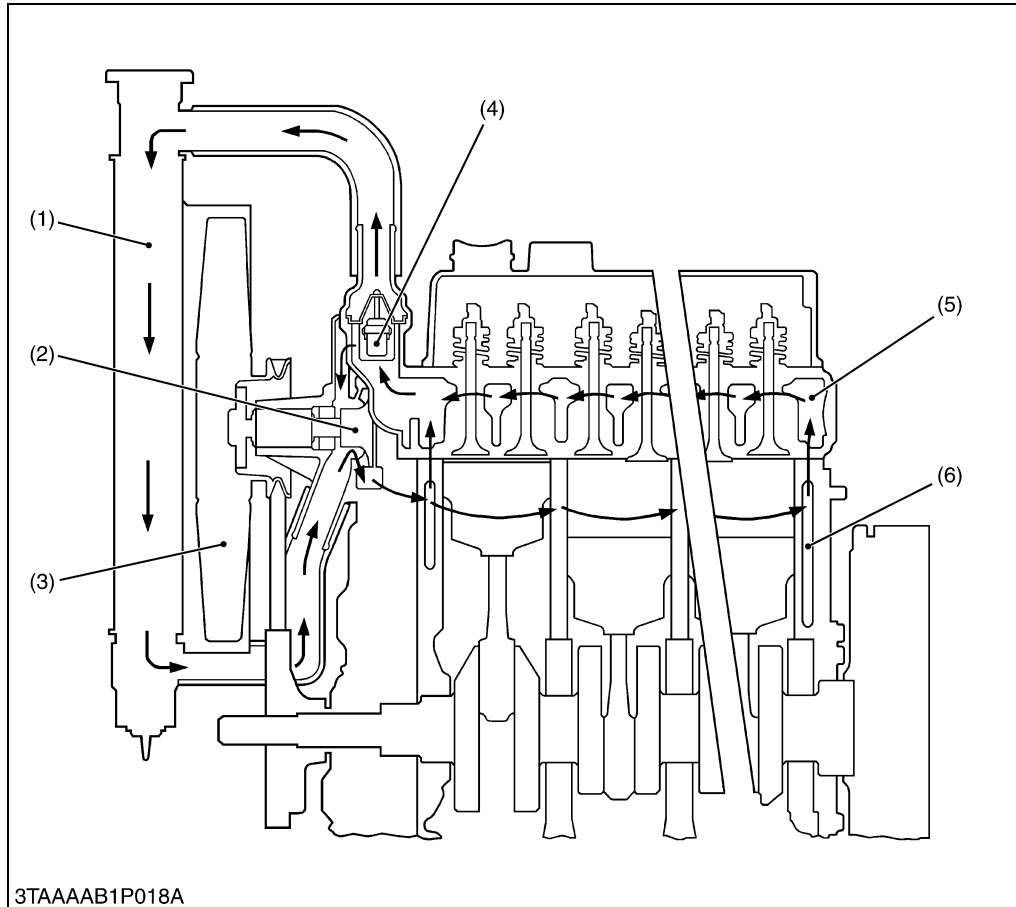

- (1) Radiator
- (2) Water Pump
- (3) Cooling Fan
- (4) Thermostat
- (5) Cylinder Head Water Jacket
- (6) Cylinder Block Water Jacket

W1016367

3TAAAB1P018A

The cooling system consists of a radiator (1), a centrifugal water pump (2), a cooling fan (3) and a thermostat (4). The water is cooled as it flows through the radiator core, and the cooling air through the radiator core by cooling fan. The water pump receives water from the radiator or from the cylinder head and force it into the cylinder block. The thermostat opens or closes according to the water temperature. When the water temperature is high, the thermostat opens to allow the water to flow form the cylinder head to the radiator. When the water temperature is low, the thermostat close to flow the water only to the water pump. The opening temperature of the thermostat is approx. 82 °C (180 °F).

[1] WATER PUMP

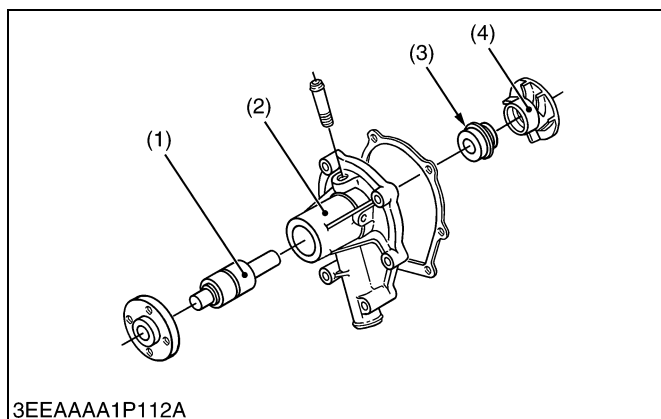

The water pump is driven with the fan drive pulley, which is on the water pump shaft and driven by the crankshaft with a belt.

The rotating impeller (4) in the water pump receives cool water from the bottom of the radiator and the water jacket of cylinder head, and sends it into the water jacket in the cylinder block.

The mechanical seal (3) prevents the water from entering the bearing (1).

- (1) Bearing Unit
- (2) Water Pump Body
- (3) Mechanical Seal
- (4) Water Pump Impeller

W1016526

3EEAAA1P112A

[2] THERMOSTAT

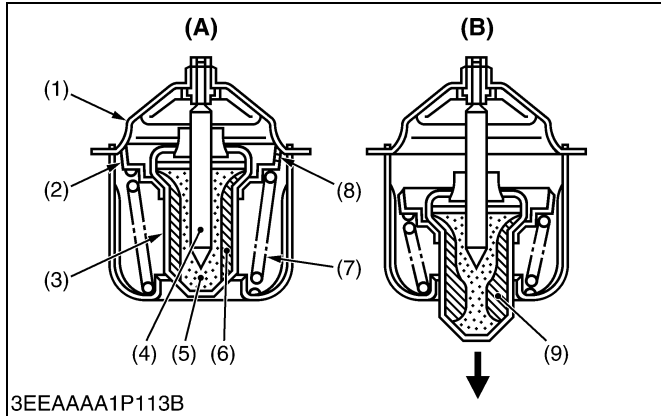

The thermostat maintains the coolant at correct temperature. KUBOTA's engine uses a wax pellet type thermostat. Wax is enclosed in the pellet. The wax is solid at low temperatures, but turns liquid at high temperatures, expands and opens the valve.

(A) At low temperature (lower than 82 °C, 180 °F)

As the thermostat is closed, coolant circulates in the engine through the water return pipe without running to the radiator.

Air in the water jacket escapes to the radiator side through leak hole (8) of the thermostat.

(B) At high temperature (higher than 82 °C, 180 °F)

When the temperature of coolant exceeds 82 °C (180 °F), wax in the pellet turns liquid and expands. Because the spindle (4) is fixed, the pellet (3) is lowered, the valve (2) is separated from the seat (1), and then coolant is sent to the radiator.

- | | |
|----------------------|------------------|
| (1) Seat | (6) Wax (Solid) |
| (2) Valve | (7) Spring |
| (3) Pellet | (8) Leak Hole |
| (4) Spindle | (9) Wax (Liquid) |
| (5) Synthetic Rubber | |

W1016639

[3] RADIATOR

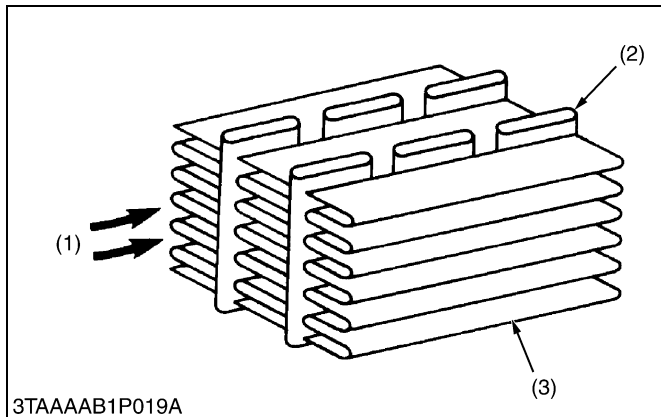

The radiator core consists of water carrying tubes (2) with fins (3) at a right angle to it.

The water in the radiator is cooled by the air flowing through between the tube wall and the fin.

The louverless corrugated fins are light in weight, high in heat exchange ratio and less in clogging by the dust.

- | | |
|-----------------|---------|
| (1) Cooling Air | (3) Fin |
| (2) Tube | |

W1017142

[4] RADIATOR CAP

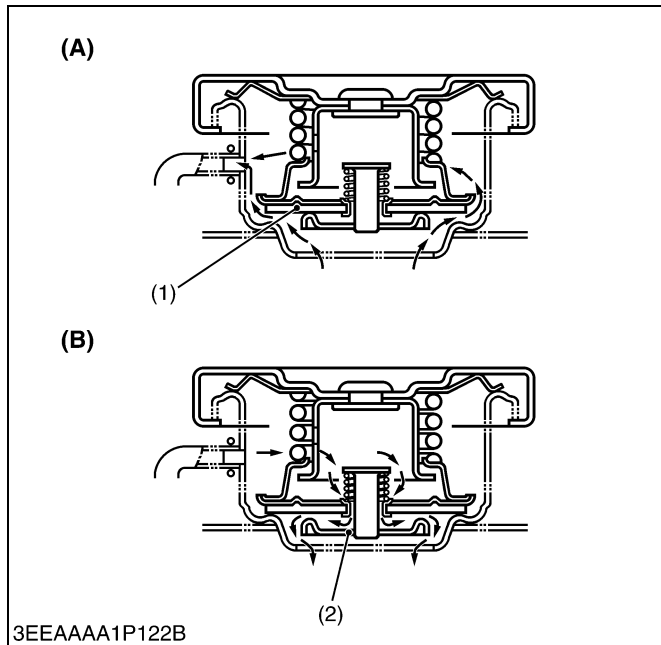

The pressure type cap is installed on the radiator, which prevents the pressure difference between the inside and the outside of the radiator from deforming the radiator.

(A) At high pressure
(higher than 88 kPa, 0.9 kgf/cm², 13 psi)

When the water temperature rises and the pressure in the radiator increase above the specified pressure, the pressure valve (1) opens to reduce the internal pressure.

(B) At negative pressure

When the water temperature falls and a vacuum is formed in the radiator, the vacuum valve (2) opens to allow the air to enter the radiator.

(1) Pressure Valve

(2) Vacuum Valve

W1017214

3EEAAAA1P122B

4. FUEL SYSTEM

[1] FUEL LINE

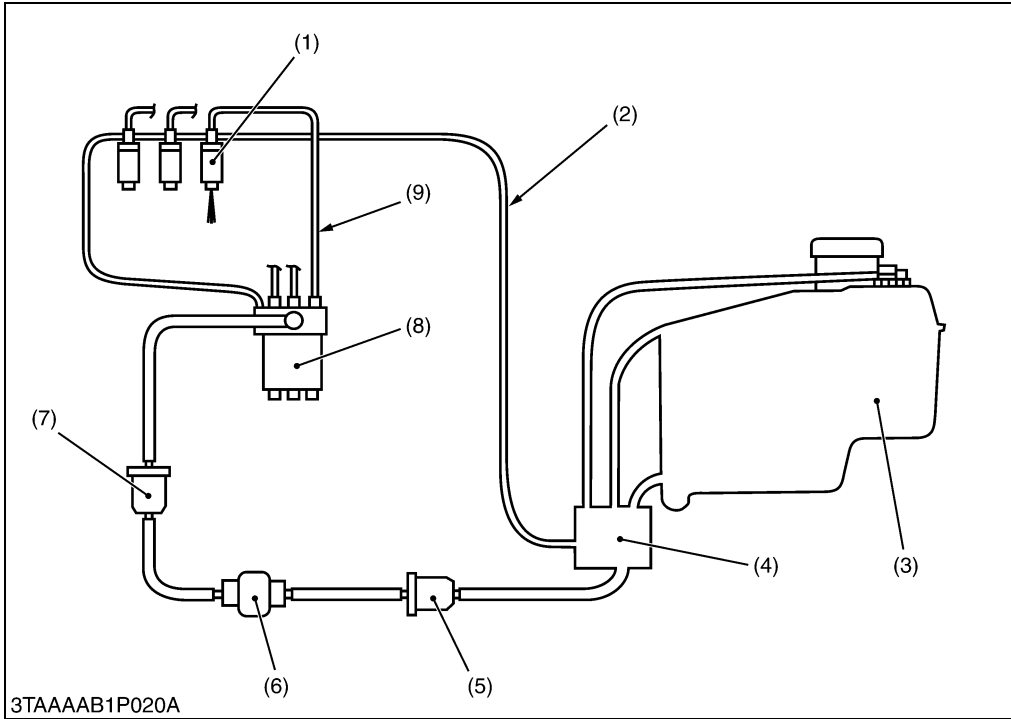

- (1) Injection Nozzle
- (2) Fuel Overflow Pipe
- (3) Fuel Tank
- (4) Fuel Tank 2
- (5) Fuel Filter
- (6) Fuel Feed Pump
- (7) Fuel Filter
- (8) Injection Pump
- (9) Injection Pipe

W1017669

Fuel from the fuel tank (3) passes through the fuel filter (5), and then enters the injection pump (8) after impurities such as dirt, water, etc. are removed.

The fuel pressurized by the injection pump to the opening pressure (13.73 to 14.71 MPa, 140 to 150 kgf/cm², 1991 to 2062 psi), of the injection nozzle (1) is injected into the combustion chamber.

Part of the fuel fed to the injection nozzle (1) lubricates the moving parts of the plunger inside the nozzle, then returns to the fuel tank through the fuel overflow pipe (2) from the upper part of the nozzle holder.

[2] FUEL FILTER

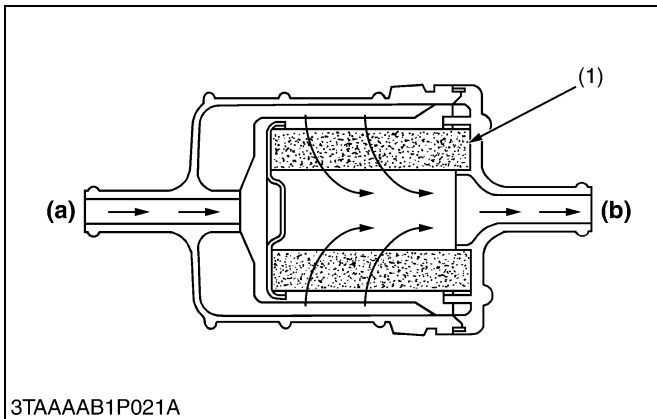

The fuel filter is installed in the fuel line between the fuel tank and injection pump.

As the fuel flows from the inlet (a) through the filter element (1), the dirt and impurities in the fuel are filtered, allowing only clean fuel to enter the inside of the filter element.

The cleaned fuel flows out from the outlet (b).

- (1) Filter Element
- (a) Inlet
- (b) Outlet

W1017778

[3] FUEL PUMP

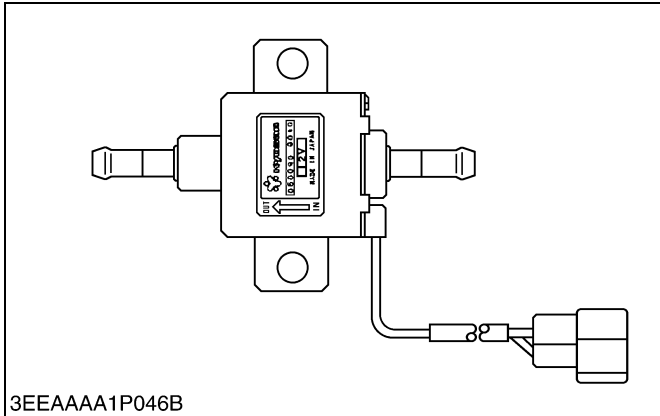

An electro magnetic fuel pump uses a transistor that causes the pump to start pumping fuel when the main switch is turned to the “ON” position.

Therefore, fuel is supplied to the injection pump regardless of engine speed. This pump is driven by the battery. It can therefore be operated even with the engine being stopped.

W1017900

[4] INJECTION PUMP

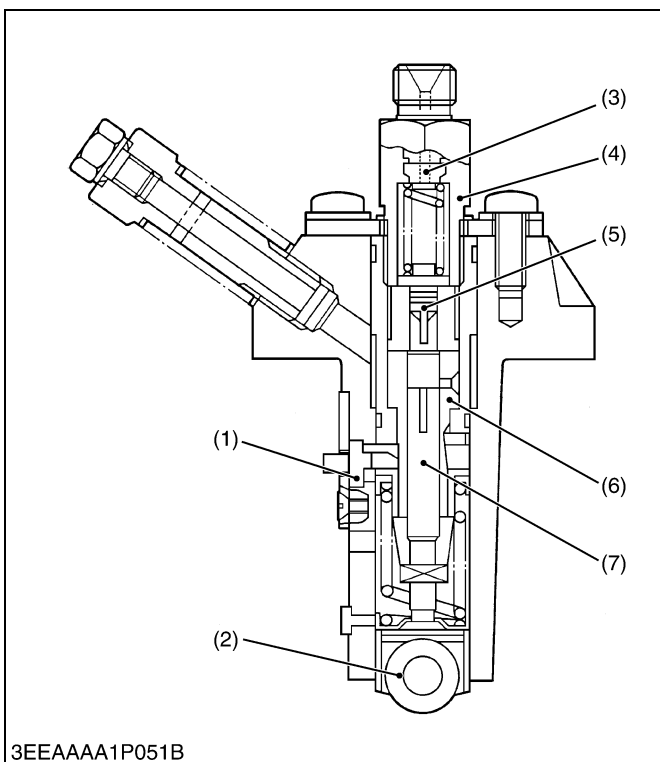

A Bosch MD type mini pump is used for the injection pump. It is small, lightweight and easy to handle.

The plunger (7) with a left-hand lead reciprocates via the tappet roller (2) by means of the fuel camshaft, causing the fuel to be delivered into the injection nozzle.

- | | |
|---------------------------|--------------------|
| (1) Control Rack | (5) Delivery Valve |
| (2) Tappet Roller | (6) Cylinder |
| (3) Dumping Valve | (7) Plunger |
| (4) Delivery Valve Holder | |

W1018110

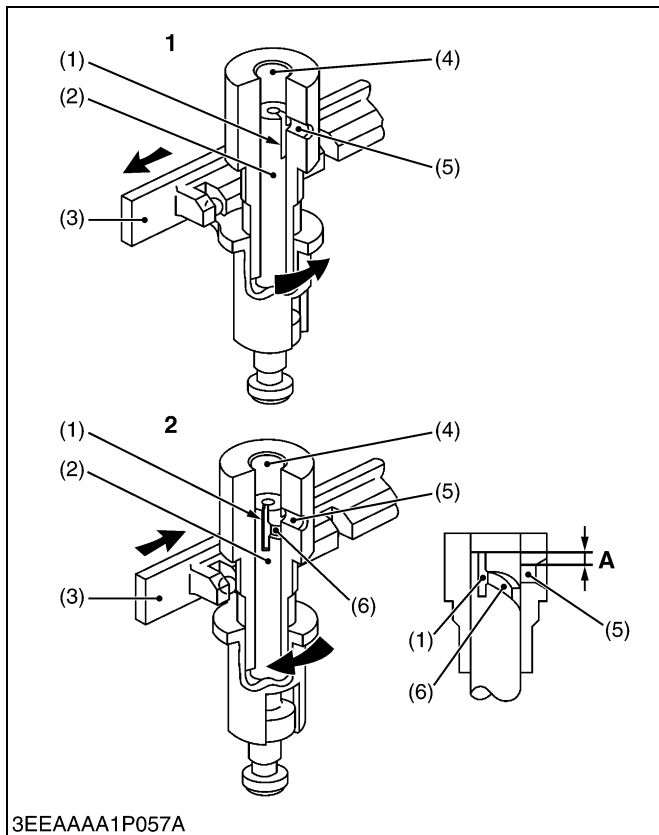

3EEAAA1P057A

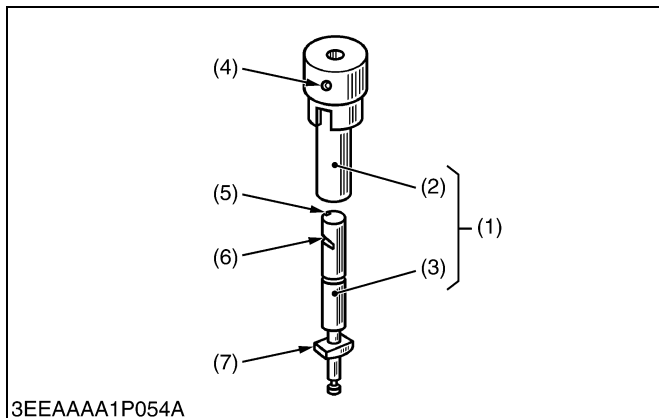

3EEAAA1P054A

■ Injection Control

1. No fuel delivery (Engine stop)

At the engine stop position of the control rack (3), the lengthwise slot (1) on the plunger (2) aligns with the feed hole (5). And the delivery chamber (4) is led to the feed hole during the entire stroke of the plunger.

The pressure in the delivery chamber does not build up and no fuel can be forced to the injection nozzle.

2. Fuel delivery

The plunger (2) is rotated (see figure) by the control rack (3).

When the plunger is pushed up, the feed hole (5) is closed. The pressure in the delivery chamber (4) builds up and forcefeeds the fuel to the injection nozzle until the control groove (6) meets the feed hole (5).

The amount of the fuel corresponds to the distance "A".

- | | |
|------------------|----------------------|
| (1) Slot | (4) Delivery Chamber |
| (2) Plunger | (5) Feed Hole |
| (3) Control Rack | (6) Control Groove |

W1018200

■ Pump Element

The pump element (1) is consist of the plunger (3) and cylinder (2).

The sliding surfaces are super-precision machined to maintain injection pressure at engine low speeds. Since the driving face (7) fits in the control sleeve, the plunger (3) is rotated by the movement of the control rack to increase or decrease of fuel delivery.

As described above, the plunger (3) is machined to have the slot (5) and the control groove (6).

- | | |
|------------------|--------------------|
| (1) Pump Element | (5) Slot |
| (2) Cylinder | (6) Control Groove |
| (3) Plunger | (7) Driving Face |
| (4) Feed Hole | |

W1018481

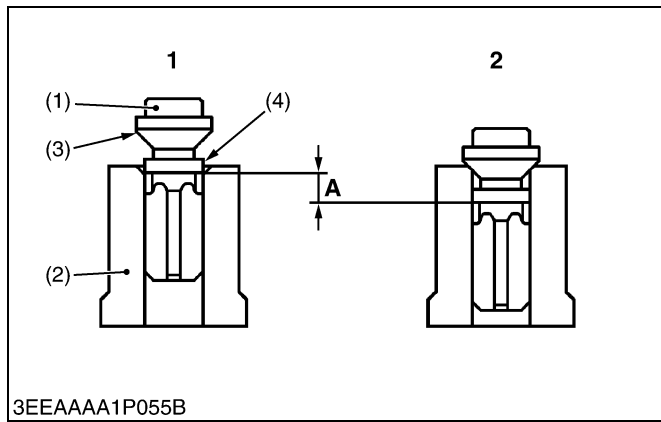

■ **Delivery Valve**

The delivery valve consists of the delivery valve (1) and delivery valve seat (2).

The delivery valve performs the following functions.

1. Reverse flow preventing function

If the fuel flow reverse from the injection nozzle side when the plunger lowers, the time lag between the next delivery start and the nozzle injection start increases. To avoid this, the delivery chamber to injection pipe interruption by delivery valve (1) prevents this reverse flow, thus keeping fuel always filled in the nozzle and pipe.

2. Suck-back function

After completing the fuel delivery, the delivery valve lowers, and the relief plunger (4) end contacts the delivery valve seat (2). The valve further lowers until its seat surface (3) seats firmly the delivery valve seat. During this time, the amount of fuel corresponding to (A) is sucked back from inside the injection pipe, the pressure inside the pipe is reduced, thus leading to an improved injection shut off and preventing after leakage dribbling.

- | | |
|-------------------------|--------------------|
| (1) Delivery Valve | (3) Seat Surface |
| (2) Delivery Valve Seat | (4) Relief Plunger |

W1018594

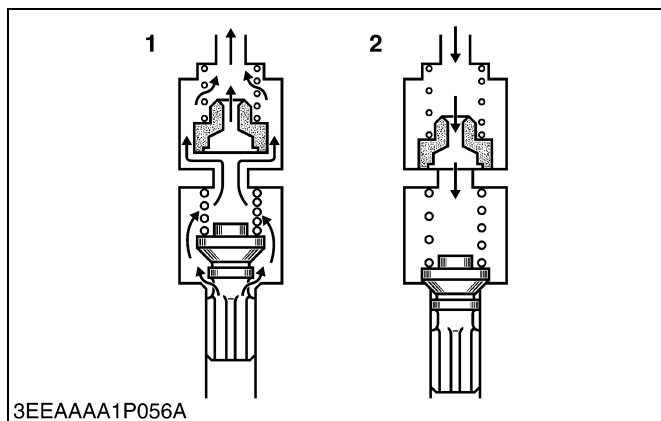

■ **Dumping Valve**

1. At fuel injection

Since dumping valve is pushed up to press the spring, fuel is pressure-fed to injection nozzle the same as without dumping valve.

2. At suck-back

At suck-back by delivery valve after fuel injection fuel returns through dumping valve orifice. Generally second injection is apt to occur by reflex pressure due to reaction of sudden pressure drop when changing into suck-back by delivery valve from high injection pressure.

As a result of preventing this second injection perfectly by dumping valve and dissolving nozzle clogging, durability of injection nozzle is improved.

W1018873

[5] INJECTION NOZZLE

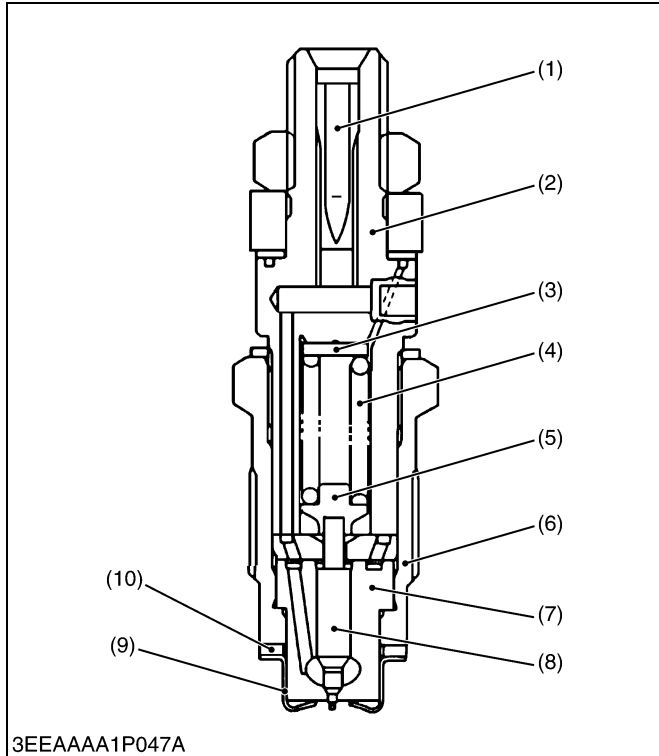

This nozzle is of a flat cut provided double throttle type. This type of nozzle is designed to control the injection quantity when the lift rate is low at start of the injection, and to cut down on the knocking sound caused by excessive fuel injection by giving the needle valve section more taper than before to prevent the rapid increase in the injection quantity when the initial injection turns into the full-force injection.

Also, employed to prevent the injection quantity loss in the throttle section caused by carbon, the flat cut provided at the needle valve section helps the throttle withstand long use and reduce as much knocking sound as when it was new.

The heat seal is employed to improve the durability and reliability of the nozzle.

The injection pressure is 13.73 to 14.71 MPa (140 to 150 kgf/cm², 1991 to 2133 psi), and is adjusted with adjusting washers (3).

- | | |
|------------------------|-------------------|
| (1) Bar Filter | (6) Retaining Nut |
| (2) Nozzle Holder Body | (7) Nozzle Body |
| (3) Adjusting Washer | (8) Needle Valve |
| (4) Nozzle Spring | (9) Heat Seal |
| (5) Push Rod | (10) Gasket |

W1018961

[6] GOVERNOR

(1) D722-E-BX

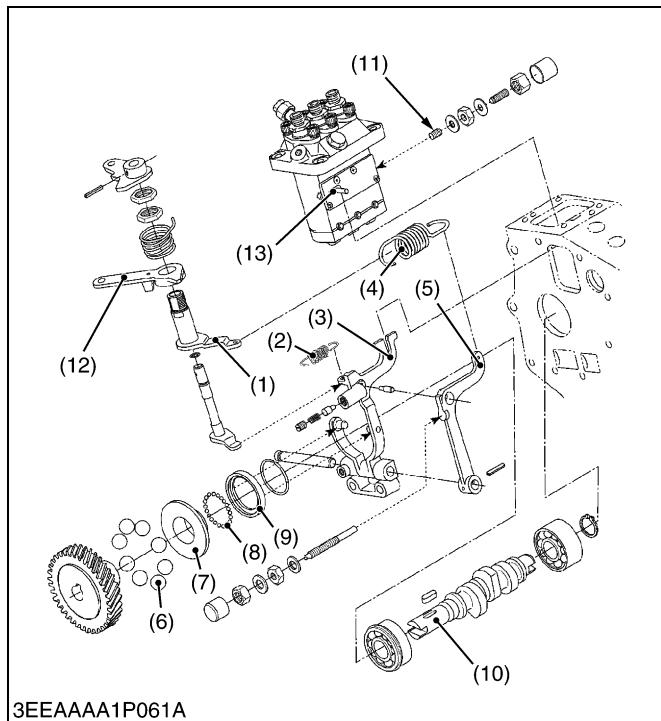

3EEAAA1P061A

The governor controls the amount of the fuel to be fed in the entire speed range to prevent the engine from changing its speed according to the load.

The fork lever 1 (3) is held where two forces on it are balanced. One is the force that fork lever 2 pushes, which is caused by the tension of the governor spring (4) between the governor lever (1) and fork lever 2 (5). Another is the component of the centrifugal force produced by the steel balls (6) which are rotated by the fuel camshaft (10).

■ At start

The steel ball (6) has no centrifugal force.

Fork lever 1 (3) is pulled by the start spring (2) and the control rod (13) moves to the maximum injection position for easy starting.

■ At idling

When the speed control lever (12) is set at the idling position, the governor spring (4) is pulled slightly.

As the camshaft rotates, the steel ball (6) increase their centrifugal force and push the governor sleeve (7). Fork lever 1 (3) pushed by the governor sleeve, pushes the control rod (13) and the control rod compresses the idling adjust spring (11).

The control rod is kept at a position where the centrifugal force is balanced with the spring tensions on the control rod, providing stable idling.

- | | |
|---------------------|------------------------------|
| (1) Governor Lever | (8) Steel Ball |
| (2) Start Spring | (9) Governor Ball Case |
| (3) Fork Lever 1 | (10) Fuel Camshaft |
| (4) Governor Spring | (11) Idling Adjusting Spring |
| (5) Fork Lever 2 | (12) Speed Control Lever |
| (6) Steel Ball | (13) Control Rod |
| (7) Governor Sleeve | |

W1019390

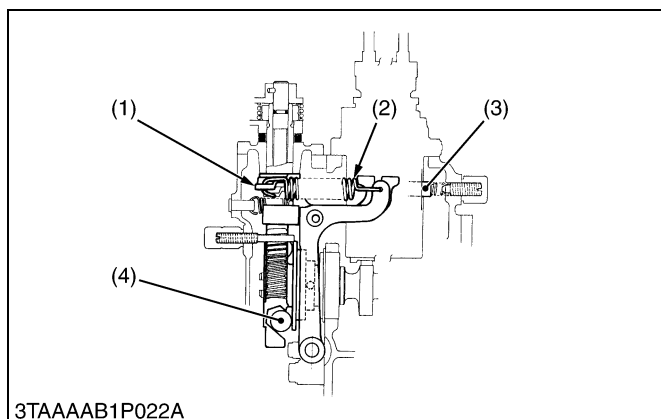

3TAAAAB1P022A

■ At medium or high speed running

When the speed control lever (1) is turned further, the governor spring (2) increases the tension and the control rod (3) is pulled to increase the engine speed.

The steel ball (4) increase their centrifugal force and the control rod is pushed, decreasing the engine speed, until the centrifugal force and the spring tension are balanced.

When the engine speed is dropped with the increase of the load, the centrifugal force of the steel ball decreases and the control rod is pulled. The amount of the fuel to the injection nozzle is increased to produce a higher engine torque required for the load.

- | | |
|-------------------------|-----------------|
| (1) Speed Control Lever | (3) Control Rod |
| (2) Governor Spring | (4) Steel Ball |

W1019615

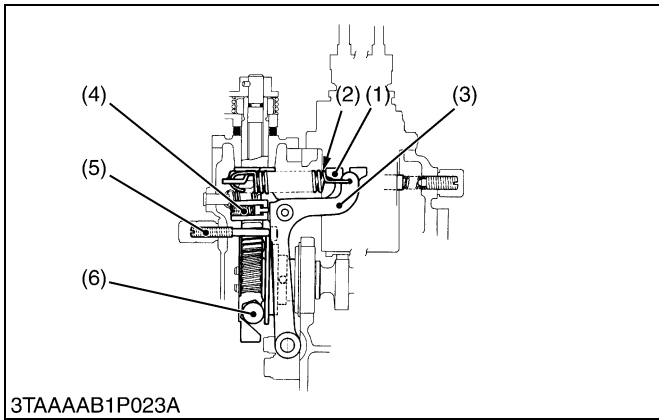

■ **At maximum speed running with an overload**

When the engine is overloaded at the high speeds and the engine speed drops, the centrifugal force of the steel ball (6) decreases and the governor spring (2) pulls fork lever 1 (1) and 2 (3).

When fork lever 2 contacts the adjusting screw (5), the spring (4) which is built in fork lever 1 begins to push the fork lever 1 to pull the control rod.

The fuel to the injection nozzle is increased to run the engine at high speed and torque.

- | | |
|---------------------|---------------------|
| (1) Fork Lever 1 | (4) Spring |
| (2) Governor Spring | (5) Adjusting Screw |
| (3) Fork Lever 2 | (6) Steel Ball |

W1019702

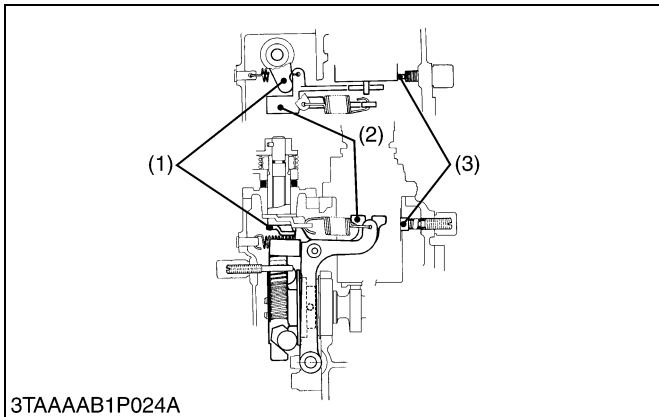

■ **To stop the engine**

When the stop lever (1) is moved to the stop position, fork lever 1 (2) is pushed and the control rod (3) is moved to stop the fuel injection.

- | | |
|------------------|-----------------|
| (1) Stop Lever | (3) Control Rod |
| (2) Fork Lever 1 | |

W1019914

(2) D905-E-BX

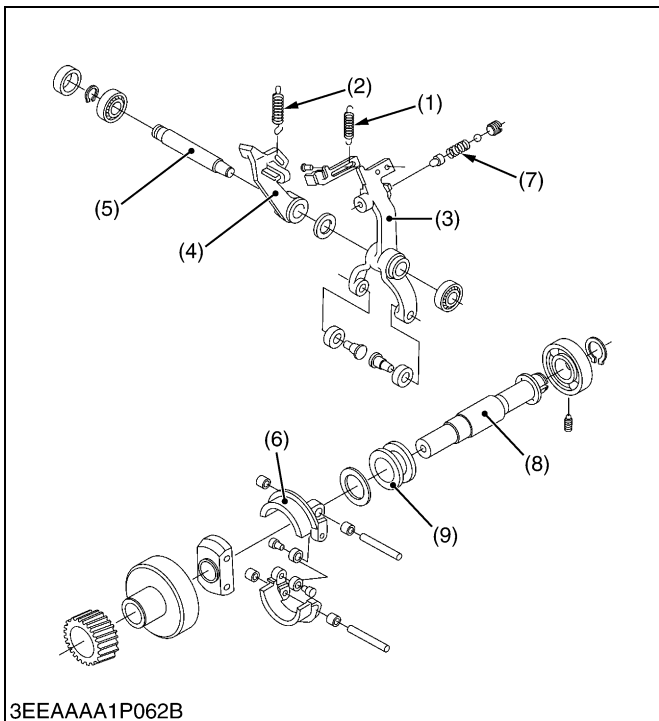

This mechanism maintains engine speed at a constant level even under fluctuating loads, provides stable idling and regulates maximum engine speed by controlling the fuel injection rate.

This engine uses a mechanical governor that controls the fuel injection rate at all speed ranges (from idling to maximum speed) by utilizing the balance between the flyweight's centrifugal force and spring tension.

A governor shaft for monitoring engine speed is independent of the injection pump shaft and rotates at twice the speed of conventional types, providing better response to load fluctuation and delivering greater engine output.

- | | |
|-----------------------|---------------------|
| (1) Start Spring | (6) Flyweight |
| (2) Governor Spring 1 | (7) Torque Spring |
| (3) Fork Lever 1 | (8) Governor Shaft |
| (4) Fork Lever 2 | (9) Governor Sleeve |
| (5) Fork Lever Shaft | |

W1019989

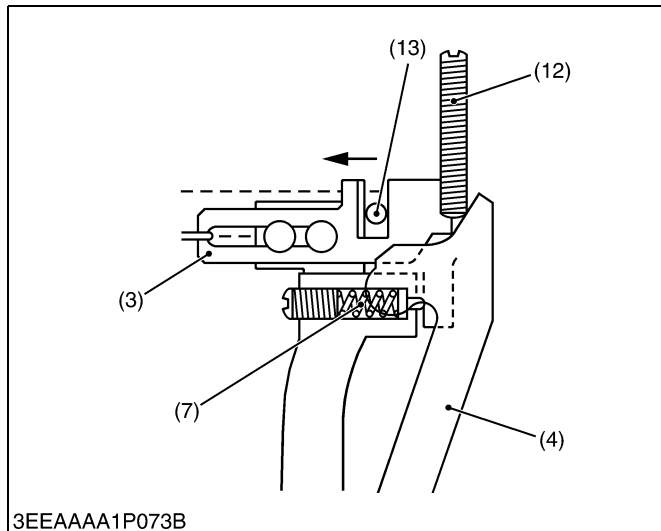
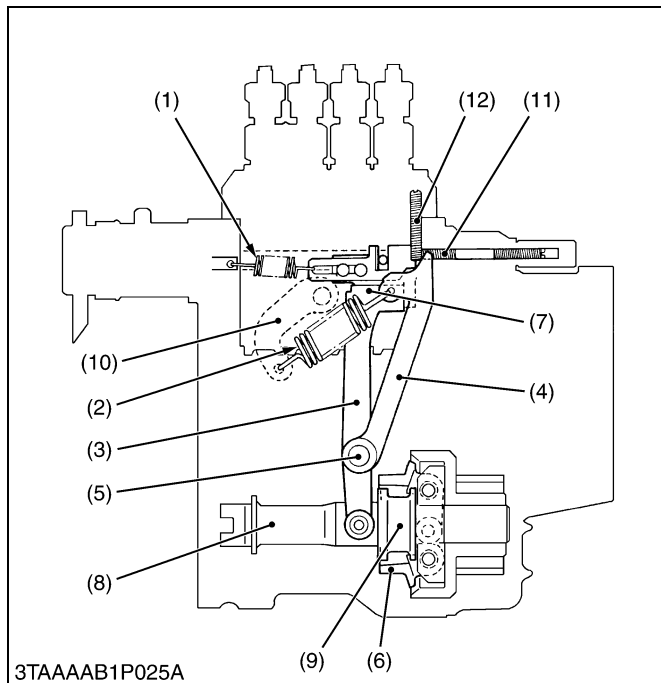

■ **At Start**

As no centrifugal force is applied to flyweight (6), low tension of start spring (1) permits control rack to move to the starting position, supplying the amount of fuel required to start the engine.

■ **At Idling**

Setting speed control lever (10) to the idling position during engine rotation permits the low tension of governor spring 1 (2), start spring (1) and idle limit spring (11) to balance the centrifugal force of flyweight (6) without activating high tension governor spring 1 (2). In this way, the fuel injection rate can be controlled to ensure stable idling.

■ **At High Speed Running with Overload**

Governor spring 1 (2) control the fuel injection rate. To maintain the required engine speed, fuel is supplied according to the speed control lever setting and load by balancing the tension of governor springs 1 and 2 with the centrifugal force of flyweight (6).

In addition, idle limit spring (11) provides stable engine rotation.

■ **During Overload**

At load increases, the engine speed decreases, reducing the flyweight's centrifugal force. Governor springs 1 (2), therefore, pull fork levers 1 (3) and 2 (4), increasing the fuel injection rate and maintaining engine speed.

If engine speed decreases due to a further increase in load, fork lever 2 (4) will come in contact with the fuel limit bolt, stopping a further increase in the fuel injection rate.

Torque spring (7) incorporated in fork lever 1 (3) moves the lever in the direction of fuel injection rate increase, thereby boosting torque and providing greater engine output.

- | | |
|-----------------------|-----------------------------|
| (1) Start Spring | (8) Governor Shaft |
| (2) Governor Spring 1 | (9) Governor Sleeve |
| (3) Fork Lever 1 | (10) Speed Control Lever |
| (4) Fork Lever 2 | (11) Idle Limit Spring |
| (5) Fork Lever Shaft | (12) Fuel Limit Adjust Bolt |
| (6) Flyweight | (13) Control Rack Pin |
| (7) Torque Spring | |

W1020096

SERVICING

CONTENTS

1. TROUBLESHOOTING	1-S1
2. SERVICING SPECIFICATIONS	1-S4
[1] D722-E-BX	1-S4
[2] D905-E-BX	1-S9
3. TIGHTENING TORQUES	1-S15
4. CHECKING, DISASSEMBLING AND SERVICING.....	1-S17
[1] SEPARATING ENGINE	1-S17
(1) Draining Coolant and Engine Oil.....	1-S17
[2] ENGINE BODY	1-S20
(1) Checking and Adjusting	1-S20
(2) Disassembling and Assembling	1-S23
(3) Servicing	1-S37
[3] LUBRICATING SYSTEM	1-S62
(1) Checking	1-S62
(2) Servicing	1-S62
[4] COOLING SYSTEM.....	1-S63
(1) Checking and Adjusting	1-S63
(2) Disassembling and Assembling	1-S65
[5] FUEL SYSTEM	1-S66
(1) Checking and Adjusting	1-S66
(2) Disassembling and Assembling	1-S69

1. TROUBLESHOOTING

Symptom	Probable Cause	Solution	Reference Page
Engine Does Not Start	<ul style="list-style-type: none"> No fuel Air in the fuel system Water in the fuel system 	Replenish fuel Bleed Change fuel and repair or replace fuel system	G-7 G-25 G-18
	<ul style="list-style-type: none"> Fuel pipe clogged Fuel filter clogged Excessively high viscosity of fuel or engine oil at low temperature Fuel with low cetane number Fuel leak due to loose injection pipe retaining nut Incorrect injection timing Fuel camshaft worn Injection nozzle clogged Injection pump malfunctioning Seizure of crankshaft, camshaft, piston, cylinder or bearing Compression leak from cylinder 	Clean Change Use specified fuel or engine oil Use specified fuel Tighten retaining nut Adjust Replace Clean Repair or replace Repair or replace Replace head gasket, tighten cylinder head screw, glow plug and nozzle holder	G-18 G-18 G-7 G-7 1-S24 1-S66 – 1-S69 – – 1-S20
(Starter Does Not Run)	<ul style="list-style-type: none"> Battery discharged Starter malfunctioning Main switch malfunctioning Safety switches malfunctioning Wiring disconnected 	Charge Repair or replace Repair or replace Adjust or replace Connect	G-16 G-14, 6-S9 – 6-S10 –
Engine Revolution Is Not Smooth	<ul style="list-style-type: none"> Fuel filter clogged or dirty Air cleaner clogged Fuel leak due to loose injection pipe retaining nut Injection pump malfunctioning Incorrect nozzle injection pressure Injection nozzle stuck or clogged Governor malfunctioning 	Change Clean or replace Tighten retaining nut Repair or replace Adjust Repair or replace Repair	G-18 G-18 1-S24 – 1-S69 1-S69 –
Either White or Blue Exhaust Gas Is Observed	<ul style="list-style-type: none"> Excessive engine oil Piston ring and cylinder worn or stuck Incorrect injection timing Deficient compression 	Reduce to specified level Repair or replace Adjust Adjust top clearance	G-12 1-S50 1-S66 1-S20

W10143220

Symptom	Probable Cause	Solution	Reference Page
Either Black or Dark Gray Exhaust Gas Is Observed	<ul style="list-style-type: none"> • Overload • Low grade fuel used • Fuel filter clogged • Air cleaner clogged • Deficient nozzle injection 	Loosen load Use specified fuel Replace Clean or replace Repair or replace nozzle	– G-7 G-18 G-18 1-S67
Deficient Output	<ul style="list-style-type: none"> • Incorrect injection timing • Engine's moving parts seem to be seizing • Uneven fuel injection • Deficient nozzle injection • Compression leak 	Adjust Repair or replace Repair or replace injection pump Repair or replace nozzle Replace head gasket, tighten cylinder head screw, glow plug and nozzle holder	1-S66 – – 1-S69 1-S20
Excessive Lubricant Oil Consumption	<ul style="list-style-type: none"> • Piston ring's gap facing the same direction • Oil ring worn or stuck • Piston ring groove worn • Valve stem and valve guide worn • Oil leaking due to defective seals or packing 	Shift ring gap direction Replace Replace piston Replace Replace	1-S50 1-S50 1-S50 1-S39 –
Fuel Mixed into Lubricant Oil	<ul style="list-style-type: none"> • Injection pump's plunger worn • Deficient nozzle injection • Injection pump broken 	Replace pump element or injection pump Repair or replace nozzle Replace	– 1-S69 1-S26, S30
Water Mixed into Lubricant Oil	<ul style="list-style-type: none"> • Head gasket defective • Cylinder block or cylinder head flawed 	Replace Replace	– 1-S38
Low Oil Pressure	<ul style="list-style-type: none"> • Engine oil insufficient • Oil strainer clogged • Oil filter clogged • Relief valve stuck with dirt • Relief valve spring weaken or broken • Excessive oil clearance of crankshaft bearing • Excessive oil clearance of crankpin bearing • Excessive oil clearance of rocker arm • Oil passage clogged • Different type of oil • Oil pump defective 	Replenish Clean Replace Clean Replace Replace Replace Replace Clean Use specified type of oil Repair or replace	– – G-12 – – 1-S55, S56 1-S53, S54 1-S42 – G-7 1-S62
High Oil Pressure	<ul style="list-style-type: none"> • Different type of oil • Relief valve defective 	Use specified type of oil Replace	G-7 –

W10143220

Symptom	Probable Cause	Solution	Reference Page
Engine Overheated	<ul style="list-style-type: none"> • Engine oil insufficient • Fan belt broken or tensioned improperly • Coolant insufficient • Radiator net and radiator fin clogged with dust • Inside of radiator corroded • Coolant flow route corroded • Radiator cap defective • Radiator hose damaged • Overload running • Head gasket defective • Incorrect injection timing • Unsuitable fuel used 	<ul style="list-style-type: none"> Replenish Replace or adjust Replenish Clean Clean or replace Clean or replace Replace Replace Loosen load Replace Adjust Use specified fuel 	<ul style="list-style-type: none"> G-7 G-18 G-7 – G-24 G-20 1-S64 G-20 – – 1-S66 G-7

W10143220

2. SERVICING SPECIFICATIONS

[1] D722-E-BX

ENGINE BODY

Item		Factory Specification	Allowable Limit
Cylinder Head Surface	Flatness	–	0.05 mm 0.0020 in.
Top Clearance		0.50 to 0.70 mm 0.0197 to 0.0276 in.	–
Compression Pressure		2.84 to 3.24 MPa 29.0 to 33.0 kgf/cm ² 412 to 469 psi	2.26 MPa 23.0 kgf/cm ² 327 psi
Variance Among Cylinders		–	10 % or less
Valve Clearance (Cold)		0.145 to 0.185 mm 0.00571 to 0.00728 in.	–
Valve Seat	Width	2.12 mm 0.0835 in.	–
Valve Seat	Angle	0.79 rad. 45 °	–
Valve Face	Angle	0.79 rad. 45 °	–
Valve Recessing		–0.10 to 0.10 mm –0.0039 to 0.0039 in.	0.30 mm 0.0118 in.
Valve Stem to Valve Guide	Clearance	0.030 to 0.057 mm 0.00118 to 0.00224 in.	0.10 mm 0.0039 in.
Valve Stem	O.D.	5.968 to 5.980 mm 0.23496 to 0.23543 in.	–
Valve Guide	I.D.	6.010 to 6.025 mm 0.23661 to 0.23720 in.	–
Valve Timing (Intake Valve)	Open	0.35 rad. (20 °) before T.D.C.	–
	Close	0.79 rad. (45 °) after B.D.C.	–
Valve Timing (Exhaust Valve)	Open	0.89 rad. (50 °) before B.D.C.	–
	Close	0.26 rad. (15 °) after T.D.C.	–

W10138740

ENGINE BODY (Continued)

Item		Factory Specification	Allowable Limit
Valve Spring	Free Length	31.3 to 31.8 mm 1.232 to 1.252 in.	28.4 mm 1.118 in.
	Setting Load	64.7 N 6.6 kgf 14.6 lbs	54.9 N 5.6 kgf 12.3 lbs
	Setting Length	27 mm 1.063 in.	—
	Tilt	—	1.2 mm 0.047 in.
Rocker Arm Shaft to Rocker Arm	Clearance	0.016 to 0.045 mm 0.00063 to 0.00177 in.	0.15 mm 0.0059 in.
Rocker Arm Shaft	O.D.	10.473 to 10.484 mm 0.41232 to 0.41276 in.	—
Rocker Arm	I.D.	10.500 to 10.518 mm 0.41339 to 0.41410 in.	—
Push Rod	Alignment	—	0.25 mm 0.0098 in.
Tappet to Tappet Guide	Clearance	0.016 to 0.052 mm 0.00063 to 0.00205 in.	0.10 mm 0.0039 in.
Tappet	O.D.	17.966 to 17.984 mm 0.70732 to 0.70803 in.	—
Tappet Guide	I.D.	18.000 to 18.018 mm 0.70866 to 0.70937 in.	—
Camshaft	Side Clearance	0.15 to 0.31 mm 0.0059 to 0.0122 in.	0.5 mm 0.02 in.
Camshaft	Alignment	—	0.02 mm 0.0008 in.
Cam Height	Intake	26.88 mm 1.0583 in.	26.83 mm 1.0563 in.
	Exhaust	26.88 mm 1.0583 in.	26.83 mm 1.0563 in.
Camshaft Journal to Cylinder Block Bore	Oil Clearance	0.050 to 0.091 mm 0.00197 to 0.00358 in.	0.15 mm 0.0059 in.
Camshaft Journal	O.D.	32.934 to 32.950 mm 1.29661 to 1.29724 in.	—
Cylinder Block Bore	I.D.	33.000 to 33.025 mm 1.29921 to 1.30020 in.	—

W10138740

ENGINE BODY (Continued)

Item		Factory Specification	Allowable Limit	
Timing Gear Crank Gear to Idle Gear	Backlash	0.043 to 0.124 mm 0.00169 to 0.00488 in.	0.15 mm 0.0059 in.	
	Idle Gear to Cam Gear	0.047 to 0.123 mm 0.00185 to 0.00484 in.	0.15 mm 0.0059 in.	
	Idle Gear to Injection Pump Gear	0.046 to 0.124 mm 0.00181 to 0.00488 in.	0.15 mm 0.0059 in.	
	Crank Gear to Oil Pump Drive Gear	0.041 to 0.123 mm 0.00161 to 0.00484 in.	0.15 mm 0.0059 in.	
Idle Gear	Side Clearance	0.13 to 0.49 mm 0.0051 to 0.0199 in.	0.60 mm 0.0236 in.	
Piston Pin Bore	I.D.	20.000 to 20.013 mm 0.78740 to 0.78791 in.	20.05 mm 0.7894 in.	
Piston Ring Clearance	Second Ring	0.090 to 0.120 mm 0.00354 to 0.00472 in.	0.15 mm 0.0059 in.	
	Oil Ring	0.04 to 0.08 mm 0.0016 to 0.0031 in.	0.15 mm 0.0059 in.	
Ring Gap	Top Ring and Second Ring	0.25 to 0.40 mm 0.0098 to 0.0157 in.	1.25 mm 0.0492 in.	
	Oil Ring	0.15 to 0.30 mm 0.0059 to 0.0118 in.	1.25 mm 0.0492 in.	
Connecting Rod	Alignment	—	0.05 mm 0.0020 in.	
Piston Pin to Small End Bushing	Clearance	0.014 to 0.038 mm 0.00055 to 0.00150 in.	0.10 mm 0.0039 in.	
	Piston Pin	O.D.	20.002 to 20.011 mm 0.78748 to 0.78783 in.	—
	Small End Bushing	I.D.	20.025 to 20.040 mm 0.78839 to 0.78897 in.	—
Crankshaft	Alignment	—	0.02 mm 0.0008 in.	
Crankshaft Journal to Crankshaft Bearing 1	Oil Clearance	0.034 to 0.106 mm 0.00134 to 0.00417 in.	0.20 mm 0.0079 in.	
	Crankshaft Journal	O.D.	39.934 to 39.950 mm 1.57221 to 1.57284 in.	—
	Crankshaft Bearing 1	I.D.	39.984 to 40.040 mm 1.57417 to 1.57638 in.	—

W10138740

ENGINE BODY (Continued)

Item		Factory Specification	Allowable Limit
Crankshaft Journal to Crankshaft Bearing 2 (Flywheel Side)	Oil Clearance	0.028 to 0.059 mm 0.00110 to 0.00232 in.	0.20 mm 0.0079 in.
	Crankshaft Journal O.D.	43.978 to 43.993 mm 1.73142 to 1.73201 in.	–
	Crankshaft Bearing 2 I.D.	43.984 to 44.026 mm 1.73165 to 1.73331 in.	–
Crankshaft Journal to Crankshaft Bearing 3 (Intermediate)	Oil Clearance	0.028 to 0.059 mm 0.00110 to 0.00232 in.	0.20 mm 0.0079 in.
	Crankshaft Journal O.D.	39.934 to 39.950 mm 1.57221 to 1.57284 in.	–
	Crankshaft Bearing 3 I.D.	39.978 to 39.993 mm 1.57394 to 1.57453 in.	–
Crankpin to Crankpin Bearing	Oil Clearance	0.020 to 0.051 mm 0.0008 to 0.00201 in.	0.15 mm 0.0059 in.
	Crankpin O.D.	33.959 to 33.975 mm 1.33697 to 1.33760 in.	–
	Crankpin Bearing I.D.	33.995 to 34.010 mm 1.33839 to 1.33898 in.	–
Crankshaft	Side Clearance	0.15 to 0.31 mm 0.0059 to 0.0122 in.	0.50 mm 0.0197 in.
Cylinder Liner [Standard]	I.D.	67.000 to 67.019 mm 2.63779 to 2.63854 in.	+ 0.15 mm 0.0059 in.
Cylinder Liner [Oversize : 0.25 mm (0.0098 in.)]	I.D.	67.250 to 67.269 mm 2.64764 to 2.64839 in.	+ 0.15 mm 0.0059 in.

W10138740

LUBRICATING SYSTEM

Engine Oil Pressure	At Idle Speed	More than 49 kPa 0.5 kgf/cm ² 7 psi	–
	At Rated Speed	196 to 441 kPa 2.0 to 4.5 kgf/cm ² 36 to 64 psi	147 kPa 1.5 kgf/cm ² 27 psi
Inner Rotor to Outer Rotor	Clearance	0.03 to 0.14 mm 0.0012 to 0.0055 in.	–
Outer Rotor to Pump Body	Clearance	0.07 to 0.15 mm 0.0028 to 0.0059 in.	–
Inner Rotor to Cover	End Clearance	0.075 to 0.135 mm 0.00295 to 0.00531 in.	–

W10139730

COOLING SYSTEM

Item		Factory Specification	Allowable Limit
Thermostat	Valve Opening Temperature (At Beginning)	80.5 to 83.5 °C 176.9 to 182.3 °F	–
	Valve Opening Temperature (Opened Completely)	95 °C 203 °F	–
Radiator	Water Leakage Test Pressure	No leaks at specified pressure 147 kPa 1.5 kgf/cm ² 21 psi	–
Radiator Cap	Pressure Falling Time	10 seconds or more 88 → 59 kPa 0.9 → 0.6 kgf/cm ² 13 → 9 psi	–
Fan Belt	Tension	7 to 9 mm / 98 N 0.28 to 0.35 in. / 98 N (10 kgf, 22 lbs)	–

W10135990

FUEL SYSTEM

Injection Pump	Injection Timing	0.31 to 0.34 rad. (17.5 to 19.5 °) before T.D.C.	–
Pump Element	Fuel Tightness	–	14.7 MPa 150 kgf/cm ² 2130 psi
Delivery Valve	Fuel Tightness	–	5 seconds 14.7 → 13.7 MPa 150 → 140 kgf/cm ² 2130 → 1990 psi
Fuel Injection Nozzle	Injection Pressure	13.7 to 14.7 MPa 140 to 150 kgf/cm ² 1990 to 2130 psi	–
Fuel Injection Nozzle Valve Seat	Fuel Tightness	When the pressure is 12.75 MPa (130 kgf/cm ² , 1849 psi), the valve seat must be fuel tightness	–

W10139730

[2] D905-E-BX

ENGINE BODY

Item		Factory Specification	Allowable Limit
Cylinder Head Surface	Flatness	–	0.05 mm 0.0020 in.
Top Clearance		0.55 to 0.70 mm 0.0217 to 0.0276 in.	–
Compression Pressure (When Cranking with Starting Motor)		2.84 to 3.24 MPa 29 to 33 kgf/cm ² 412 to 469 psi	2.26 MPa 23 kgf/cm ² 327 psi
Variance among Cylinders		–	10 % or less
Valve Clearance (Cold)		0.145 to 0.185 mm 0.0057 to 0.0072 in.	–
Valve Seat	Width	2.12 mm 0.0835 in.	–
Valve Seat	Angle (Intake)	1.047 rad. 60 °	–
	Angle (Exhaust)	0.785 rad. 45 °	–
Valve Face	Angle (Intake)	1.047 rad. 60 °	–
	Angle (Exhaust)	0.785 rad. 45 °	–
Valve Recessing		–0.05 to 0.15 mm –0.0020 to 0.0059 in.	0.40 mm 0.0157 in.
Valve Stem to Valve Guide	Clearance	0.035 to 0.065 mm 0.0014 to 0.0026 in.	0.10 mm 0.0039 in.
Valve Stem	O.D.	6.960 to 6.975 mm 0.2740 to 0.2746 in.	–
Valve Guide	I.D.	7.010 to 7.025 mm 0.2760 to 0.2766 in.	–
Valve Timing (Intake Valve)	Open	0.24 rad. (14 °) before T.D.C.	–
	Close	0.52 rad. (30 °) after B.D.C.	–
Valve Timing (Exhaust Valve)	Open	0.96 rad. (55 °) before B.D.C.	–
	Close	0.24 rad. (14 °) after T.D.C.	–

W10138740

ENGINE BODY (Continued)

Item		Factory Specification	Allowable Limit
Valve Spring	Free Length	37.0 to 37.5 mm 1.457 to 1.476 in.	36.5 mm 1.437 in.
	Setting Load	117.6 N 12.0 kgf 26.4 lbs	100.0 N 10.2 kgf 22.5 lbs
	Setting Length	31.0 mm 1.220 in.	–
	Tilt	–	1.0 mm 0.039 in.
Rocker Arm Shaft to Rocker Arm	Clearance	0.016 to 0.045 mm 0.0006 to 0.0018 in.	0.10 mm 0.0039 in.
Rocker Arm Shaft	O.D.	11.973 to 11.984 mm 0.4714 to 0.4718 in.	–
Rocker Arm	I.D.	12.000 to 12.018 mm 0.4724 to 0.4732 in.	–
Push Rod	Alignment	–	0.25 mm 0.0098 in.
Tappet to Tappet Guide	Clearance	0.020 to 0.062 mm 0.00079 to 0.00244 in.	0.07 mm 0.0028 in.
Tappet	O.D.	19.959 to 19.980 mm 0.78579 to 0.78661 in.	–
Tappet Guide	I.D.	20.000 to 20.021 mm 0.78740 to 0.78823 in.	–
Camshaft	Side Clearance	0.07 to 0.22 mm 0.0028 to 0.0087 in.	0.30 mm 0.0118 in.
Camshaft	Alignment	–	0.01 mm 0.0004 in.
Cam Height	Intake	28.80 mm 1.1339 in.	28.75 mm 1.1319 in.
	Exhaust	29.00 mm 1.1417 in.	28.95 mm 1.1398 in.
Camshaft Journal to Cylinder Block Bore	Oil Clearance	0.050 to 0.091 mm 0.00197 to 0.00358 in.	0.15 mm 0.0059 in.
Camshaft Journal	O.D.	35.934 to 35.950 mm 1.41472 to 1.41535 in.	–
Cylinder Block Bore	I.D.	36.000 to 36.025 mm 1.41732 to 1.41831 in.	–

W10138740

ENGINE BODY (Continued)

Item		Factory Specification	Allowable Limit	
Timing Gear Crank Gear to Idle Gear	Backlash	0.032 to 0.115 mm 0.00126 to 0.00453 in.	0.15 mm 0.0059 in.	
	Idle Gear to Cam Gear	0.036 to 0.114 mm 0.00142 to 0.00449 in.	0.15 mm 0.0059 in.	
	Idle Gear to Injection Pump Gear	0.034 to 0.116 mm 0.00134 to 0.00457 in.	0.15 mm 0.0059 in.	
	Injection Pump Gear to Governor Gear	0.030 to 0.118 mm 0.0018 to 0.0046 in.	0.15 mm 0.0059 in.	
Idle Gear	Side Clearance	0.20 to 0.51 mm 0.0079 to 0.0200 in.	0.8 mm 0.0315 in.	
Idle Gear Shaft to Idle Gear Bushing	Clearance	0.020 to 0.054 mm 0.00079 to 0.00213 in.	0.10 mm 0.0039 in.	
	Idle Gear Shaft	O.D.	25.967 to 25.980 mm 1.02232 to 1.02283 in.	–
	Idle Gear Bushing	I.D.	26.000 to 26.021 mm 1.02362 to 1.02445 in.	–
Piston Pin Bore	I.D.	22.000 to 22.013 mm 0.86614 to 0.86675 in.	22.05 mm 0.8681 in.	
Piston Ring Clearance	Second Ring	0.085 to 0.112 mm 0.0033 to 0.0044 in.	0.20 mm 0.0079 in.	
	Oil Ring	0.020 to 0.055 mm 0.00079 to 0.00217 in.	0.15 mm 0.0059 in.	
Piston Ring Gap	Top Ring and Second Ring	0.25 to 0.40 mm 0.0098 to 0.0157 in.	1.25 mm 0.0492 in.	
	Oil Ring	0.25 to 0.45 mm 0.0098 to 0.0177 in.	1.25 mm 0.0492 in.	
Connecting Rod	Alignment	–	0.05 mm 0.0020 in.	
Piston Pin to Small End Bushing	Clearance	0.014 to 0.038 mm 0.00055 to 0.00150 in.	0.15 mm 0.0059 in.	
	Piston Pin	O.D.	22.002 to 22.011 mm 0.86622 to 0.86657 in.	–
	Small End Bushing	I.D.	22.025 to 22.040 mm 0.86713 to 0.86771 in.	–
Crankshaft	Alignment	–	0.02 mm 0.0008 in.	

W10138740

ENGINE BODY (Continued)

Item		Factory Specification	Allowable Limit
Crankshaft Journal to Crankshaft Bearing 1	Oil Clearance	0.034 to 0.114 mm 0.00134 to 0.00449 in.	0.20 mm 0.0079 in.
	Crankshaft Journal O.D.	47.934 to 47.950 mm 1.88717 to 1.88779 in.	–
	Crankshaft Bearing 1 I.D.	47.984 to 48.048 mm 1.88913 to 1.89165 in.	–
Crankshaft Journal to Crankshaft Bearing 2	Oil Clearance	0.034 to 0.095 mm 0.00134 to 0.00374 in.	0.20 mm 0.0079 in.
	Crankshaft Journal O.D.	47.934 to 47.950 mm 1.88716 to 1.88779 in.	–
	Crankshaft Bearing 2 I.D.	47.984 to 48.029 mm 1.88913 to 1.89091 in.	–
Crankpin to Crankpin Bearing	Oil Clearance	0.029 to 0.091 mm 0.00114 to 0.00358 in.	0.20 mm 0.0079 in.
	Crankpin O.D.	39.959 to 39.975 mm 1.57319 to 1.57382 in.	–
	Crankpin Bearing I.D.	40.004 to 40.050 mm 1.57496 to 1.57677 in.	–
Crankshaft Journal to Crankshaft Bearing 3	Oil Clearance	0.034 to 0.098 mm 0.00134 to 0.00386 in.	0.20 mm 0.0079 in.
	Crankshaft Journal O.D.	51.921 to 51.940 mm 2.04413 to 2.04488 in.	–
	Crankshaft Bearing 3 I.D.	51.974 to 52.019 mm 2.04622 to 2.04799 in.	–
Crankshaft	Side Clearance	0.15 to 0.31 mm 0.0059 to 0.0122 in.	0.50 mm 0.0197 in.
Cylinder [Standard]	I.D.	72.000 to 72.019 mm 2.8346 to 2.8353 in.	72.169 mm 2.8413 in.
Cylinder [Oversize : 0.5 mm (0.0197 in.)]	I.D.	72.500 to 72.519 mm 2.8543 to 2.8551 in.	72.669 mm 2.8610 in.

W10138740

LUBRICATING SYSTEM

Item		Factory Specification	Allowable Limit
Engine Oil Pressure	At Idle Speed	More than 49 kPa 0.5 kgf/cm ² 7 psi	—
	At Rated Speed	196 to 441 kPa 2.0 to 4.5 kgf/cm ² 36 to 64 psi	147 kPa 1.5 kgf/cm ² 27 psi
Inner Rotor to Outer Rotor	Clearance	0.06 to 0.18 mm 0.0024 to 0.0071 in.	—
Outer Rotor to Pump Body	Clearance	0.100 to 0.180 mm 0.0039 to 0.0071 in.	—
Rotor to Cover	Clearance	0.030 to 0.085 mm 0.0012 to 0.0033 in.	—

W10139730

COOLING SYSTEM

Thermostat	Valve Opening Temperature (At Beginning)	80.5 to 83.5 °C 176.9 to 182.3 °F	—
	Valve Opening Temperature (Opened Completely)	95 °C 203 °F	—
Radiator	Water Leakage Test Pressure	No leaks at 137 kPa 1.4 kgf/cm ² 20 psi	—
Radiator Cap	Pressure Falling Time	10 seconds or more for pressure falling from 88 to 59 kPa from 0.9 to 0.6 kgf/cm ² from 13 to 9 psi	—
Fan Belt	Tension	7 to 9 mm (0.28 to 0.35 in.) deflection at 98 N (10 kgf, 22 lbs) of force	—

W10135990

FUEL SYSTEM

Item		Factory Specification	Allowable Limit
Injection Pump	Injection Timing	0.35 to 0.38 rad. 20 to 22 ° before T.D.C.	–
Pump Element	Fuel Tightness	–	14.7 MPa 150 kgf/cm ² 2133 psi
Delivery Valve	Fuel Tightness	10 seconds or more for pressure falling from 14.7 to 13.7 MPa from 150 to 140 kgf/cm ² from 2133 to 1990 psi	5 seconds for pressure falling from 14.7 to 13.7 MPa from 150 to 140 kgf/cm ² from 2133 to 1990 psi
Fuel Injection Nozzle	Injection Pressure	13.71 to 14.71 MPa 140 to 150 kgf/cm ² 1990 to 2130 psi	–
Fuel Injection Nozzle Valve Seat	Valve Seat Tightness	When the pressure is 12.75 MPa (130 kgf/cm ² , 1849 psi), the valve seat must be fuel tightness.	–

W10139730

3. TIGHTENING TORQUES

Tightening torques of screws, bolts and nuts on the table below are especially specified.
 (For general use screws, bolts and nuts : See page G-8.)

Item	N-m	kgf-m	ft-lbs
Cushion mounting nut	48.1	4.9	35.4
Engine mounting nut	48.1	4.9	35.4
Engine support screw	48.1 to 55.9	4.9 to 5.7	35.4 to 41.2
Front coupling mounting screw	23.5 to 27.4	2.4 to 2.8	17.3 to 20.2
Under cover mounting bolt and nut	7.8 to 8.8	0.8 to 0.9	5.8 to 6.5

W10127360

[D722-E-BX]

Item	Size × Pitch	N-m	kgf-m	ft-lbs
Air cleaner stay screw	M6 × 1.0	9.8 to 11.3	1.00 to 1.15	7.23 to 8.32
	M8 × 1.25	23.5 to 27.5	2.4 to 2.8	17.4 to 20.3
* Connecting rod screw	M7 × 0.75	26.5 to 30.4	2.7 to 3.1	19.5 to 22.4
* Cylinder head cover cap nut	M6 × 1.0	3.9 to 5.9	0.4 to 0.6	2.9 to 4.3
* Cylinder head screw	M8 × 1.25	37.2 to 42.1	3.8 to 4.3	28.0 to 31.7
* Fan drive pulley screw	M12 × 1.5	98.0 to 107.8	10.0 to 11.0	73.8 to 81.2
* Flywheel mounting screw	M10 × 1.25	53.9 to 58.8	5.5 to 6.0	39.8 to 43.4
Glow plug	M8 × 1.0	7.8 to 14.7	0.8 to 1.5	5.8 to 10.8
Idle gear shaft mounting nut	M6 × 1.0	9.8 to 11.3	1.00 to 1.15	7.2 to 8.3
Injection pipe retaining nut	M12 × 1.5	24.5 to 34.3	2.5 to 3.5	18.1 to 25.3
* Main bearing case screw 1	M8 × 1.25	23.6 to 27.4	2.4 to 2.8	17.4 to 20.2
* Main bearing case screw 2	M7 × 1.0	26.5 to 30.4	2.7 to 3.1	19.5 to 22.5
Nozzle holder		34.3 to 39.2	3.5 to 4.0	25.3 to 28.9
Nozzle holder assembly	M20 × 1.5	49.0 to 68.6	5.0 to 7.0	36.2 to 50.6
Oil pressure switch	PT 1/8	14.7 to 19.6	1.5 to 2.0	10.8 to 14.5
Overflow pipe assembly retaining nut	M12 × 1.5	19.6 to 24.5	2.0 to 2.5	14.5 to 18.1
* Rocker arm bracket nut	M6 × 1.0	9.8 to 11.3	1.00 to 1.15	7.2 to 8.3

W10165810

[D905-E-BX]

Item	Size × Pitch	N-m	kgf-m	ft-lbs
Air cleaner stay nut	M10 × 1.25	48.1 to 55.9	4.9 to 5.7	35.4 to 41.2
* Bearing case cover screw	M6 × 1.0	9.8 to 11.3	1.00 to 1.15	7.2 to 8.3
Connecting rod screw	M8 × 1.0	41.2 to 46.1	4.2 to 4.7	30.3 to 33.9
* Cylinder head cover cap nut	M7 × 1.0	6.9 to 8.8	0.7 to 0.9	5.1 to 6.5
* Cylinder head screw	M10 × 1.25	63.7 to 68.6	6.5 to 7.0	47.0 to 50.6
* Fan drive pulley screw	M14 × 1.5	235.4 to 245.2	24.0 to 25.0	173.6 to 180.8
* Flywheel	M10 × 1.25	53.9 to 58.8	5.5 to 6.0	39.8 to 43.4
Glow plug	M8 × 1.0	7.8 to 14.7	0.8 to 1.5	5.8 to 10.8
* Idle gear shaft mounting screw	M6 × 1.0	9.8 to 11.3	1.00 to 1.15	7.2 to 8.3
Injection pipe retaining nut	M12 × 1.5	24.5 to 34.3	2.5 to 3.5	18.1 to 25.3
* Main bearing case screw 1	M8 × 1.25	29.4 to 34.3	3.0 to 3.5	21.7 to 25.3
* Main bearing case screw 2	M9 × 1.25	49.0 to 53.9	5.0 to 5.5	36.2 to 39.8
Nozzle holder		34.3 to 39.2	3.5 to 4.0	25.3 to 28.9
Nozzle holder assembly	M20 × 1.5	49.0 to 68.6	5.0 to 7.0	36.2 to 50.6
* Oil pressure switch	PT 1/8	14.7 to 19.6	1.5 to 2.0	10.8 to 14.5
Overflow pipe assembly retaining nut	M12 × 1.5	19.6 to 24.5	2.0 to 2.5	14.5 to 18.1
* Rocker arm bracket nut	M7 × 1.0	21.6 to 26.5	2.2 to 2.7	15.9 to 19.5

NOTE

- In removing and applying the bolts and nuts marked with “*”, a pneumatic wrench or similar pneumatic tool, if employed, must be used with enough care not to get them seized.
- For * marked screws, bolts and nuts on the table, apply engine oil to their threads and seats before tightening.
- The letter “M” in Size × Pitch means that the screw, bolt or nut dimension stands for metric. The size is the nominal outside diameter in mm of the threads. The pitch is the nominal distance in mm between two threads.

W10132360

4. CHECKING, DISASSEMBLING AND SERVICING

[1] SEPARATING ENGINE

(1) Draining Coolant and Engine Oil

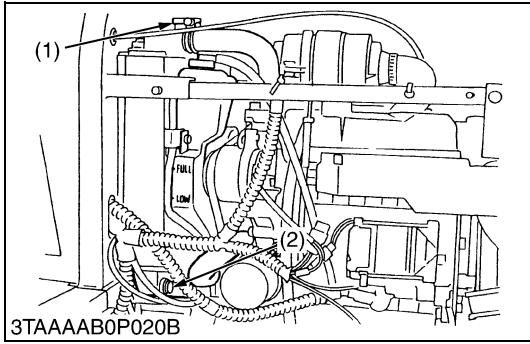

Draining Coolant

⚠ CAUTION

- Never open the radiator cap while operating or immediately after stopping. Otherwise, hot water will spout out from the radiator. Wait for more than ten minutes to cool the radiator, before opening the cap.

1. Open the radiator drain plug (2), and remove radiator cap (1) to completely drain the coolant.
2. After all coolant is drained, close the drain plug (2).

[D722]

Coolant	Capacity	Radiator	2.5 L 2.64 U.S.qts. 2.20 Imp.qts.
		Recovery tank	0.4 L 0.42 U.S.qts. 0.35 Imp.qts.

[D905]

Coolant	Capacity	Radiator	3.1 L 3.28 U.S.qts. 2.73 Imp.qts.
		Recovery tank	0.4 L 0.42 U.S.qts. 0.35 Imp.qts.

(1) Radiator Cap

(2) Drain Plug

W1013828

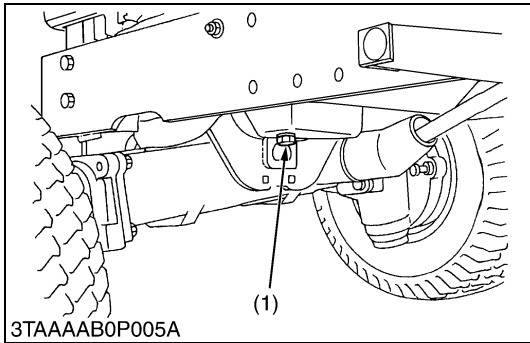

Draining Engine Oil

1. Start and warm up the engine for approx. 5 minutes.
2. Place an oil pan underneath the engine.
3. Remove the drain plug (1) to drain oil.
4. After draining, screw in the drain plug (1).

(When refilling)

- Fill the engine oil up to the upper line on the dipstick (3).

■ IMPORTANT

- Never mix two different type of oil.
- Use the proper SAE Engine Oil according to ambient temperature.

Refer to “LUBRICANTS, FUEL AND COOLANT”. (See page G-7.)

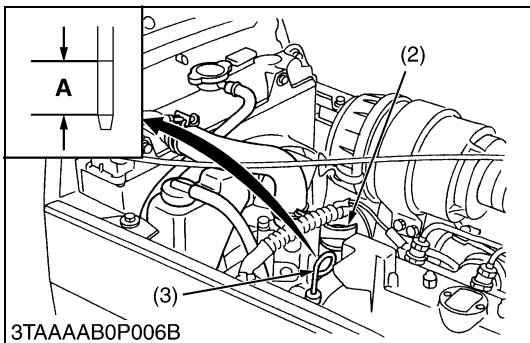

Engine oil	Capacity	D722	1.9 L 2.01 U.S.qts. 1.67 Imp.qts.
		D905	2.5 L 2.64 U.S.qts. 2.20 Imp.qts.

- (1) Drain Plug
- (2) Oil Inlet Plug
- (3) Dipstick

A : Oil level is acceptable within this range

W1014003

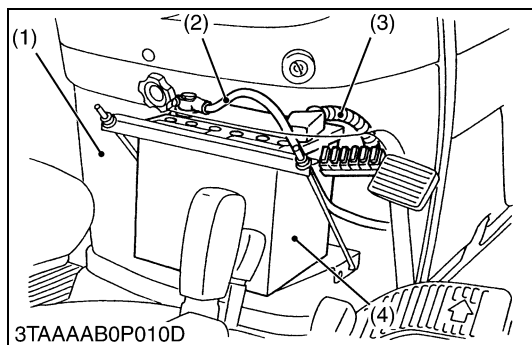

Battery

⚠ CAUTION

• When disconnecting the battery cables, disconnect the negative cable from the battery first. When connecting, connect the positive cable to the battery first.

1. Remove the under panel (1).
2. Disconnect the negative cable (2) from the battery.
3. Disconnect the positive cable (3) from the battery and remove the battery (4).

- (1) Under Panel (3) Positive Cable
 (2) Negative Cable (4) Battery

W1014211

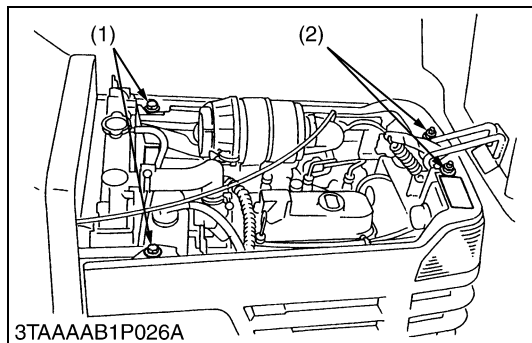

Under Cover

1. Remove the under cover mounting bolts (1), loosen the mounting nuts (2) and pull forward to remove the under cover (3).

(When reassembling)

Tightening torque	Under cover mounting bolt and nut	7.8 to 8.8 N·m 0.8 to 0.9 kgf·m 5.8 to 6.5 ft-lbs
-------------------	-----------------------------------	---

- (1) Under Cover Mounting Bolt (3) Under Cover
 (2) Under Cover Mounting Nut

W1014346

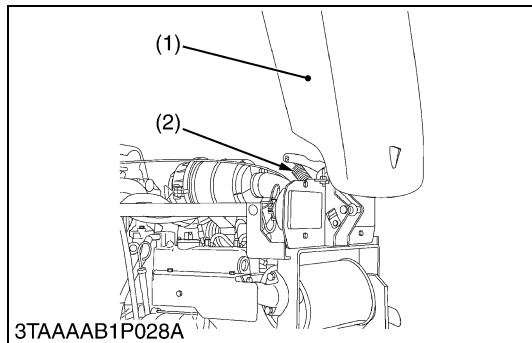
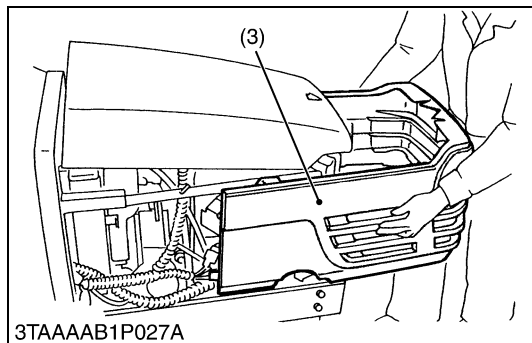

Bonnet

1. Remove the spring (2).
2. Remove the bonnet mounting bolt and nut, and remove the bonnet (1).

- (1) Bonnet (2) Spring

W1014501

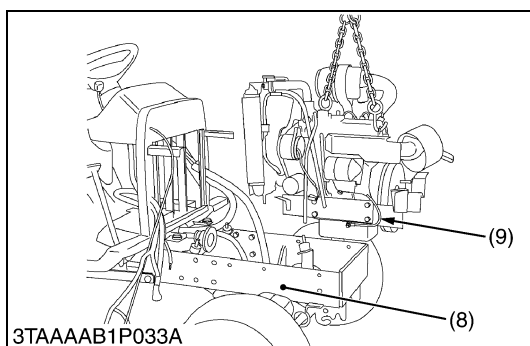
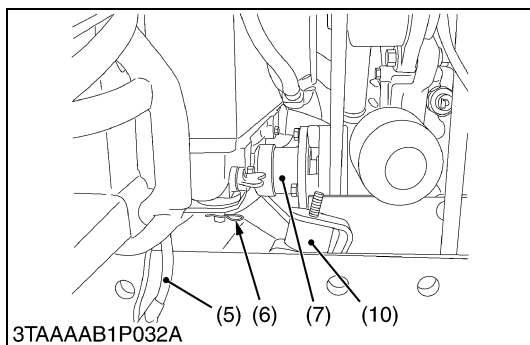
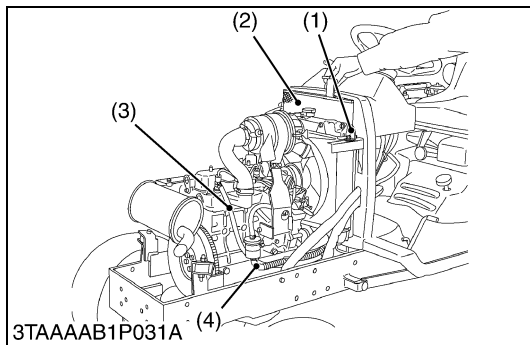
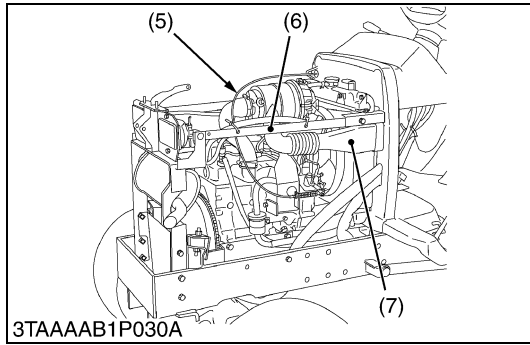
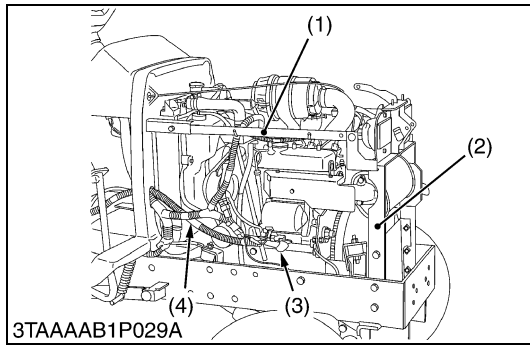

Bonnet Post, Support and Others

1. Disconnect the wire harness (4) and battery positive cable (3).
2. Disconnect the accelerator wire (5).
3. Remove the intake pipe (7).
4. Remove the supports (1), (6) and bonnet post (2).

- | | |
|--------------------|----------------------|
| (1) Support RH | (5) Accelerator Wire |
| (2) Bonnet Post | (6) Support LH |
| (3) Positive Cable | (7) Intake Pipe |
| (4) Wire Harness | |

W1014587

Engine Assembly

1. Disconnect the fuel hoses (3) and (4).
2. Remove the radiator net (2) and radiator stay (1).
3. Disconnect the battery negative cable (5), ground cable (9) and front coupling (7).
4. Remove the engine mounting nuts and radiator retaining snap pins (6).
5. Separate the engine assembly with radiator from the frame (8).

(When reassembling)

Tightening torque	Front coupling mounting screw	23.5 to 27.4 N·m 2.4 to 2.8 kgf·m 17.3 to 20.2 ft-lbs
	Engine mounting nut	48.1 N·m 4.9 kgf·m 35.4 ft-lbs
	Cushion mounting nut	48.1 N·m 4.9 kgf·m 35.4 ft-lbs

- | | |
|----------------------------|---------------------------------|
| (1) Radiator Stay | (6) Radiator Retaining Snap Pin |
| (2) Radiator Net | (7) Front Coupling |
| (3) Fuel Hose | (8) Frame |
| (4) Fuel Hose | (9) Ground Cable |
| (5) Battery Negative Cable | (10) Cushion |

W1014832

[2] ENGINE BODY

(1) Checking and Adjusting

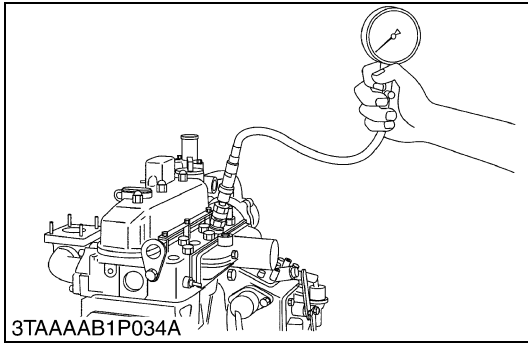

Compression Pressure

1. Run the engine until it is warmed up.
2. Stop the engine.
3. Disconnect the **2P** connector from the fuel pump.
4. Remove the air cleaner, the muffler and all injection nozzles.
5. Disconnect the accelerator wire.
6. Engage the parking brake.
7. Set a compression tester (Code No. 07909-30208) with the adaptor (Adaptor H, code No. 07909-31231) to the nozzle hole.
8. While cranking the engine with the starter, measure the compression pressure.
9. Repeat steps 7 and 8 for each cylinder.
10. If the measurement is below the allowable limit, apply a small amount of oil to the cylinder wall through the nozzle hole and measure the compression pressure again.
11. If the compression pressure is still less than the allowable limit, check the top clearance, valve clearance and cylinder head.
12. If the compression pressure increases after applying oil, check the cylinder wall and piston rings.

■ NOTE

- Check the compression pressure with the specified valve clearance.
- Always use a fully charged battery for performing this test.
- Variances in cylinder compression values should be under 10 %.

Compression pressure	Factory spec.	2.84 to 3.24 MPa 29.0 to 33.0 kgf/cm ² 412 to 469 psi
	Allowable limit	2.26 MPa 23.0 kgf/cm ² 327 psi

W10178940

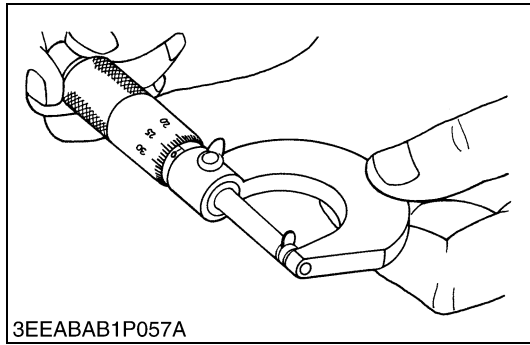
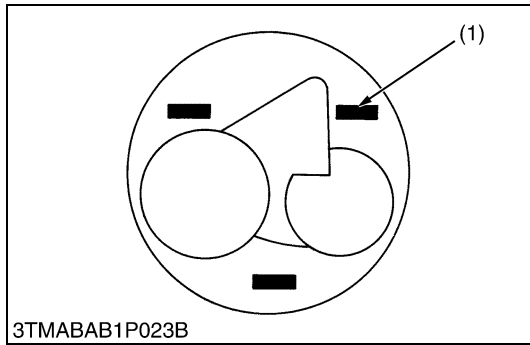

Top Clearance

1. Remove the cylinder head. (Do not attempt to remove the cylinder head gasket.)
2. Move the piston up, and stick a strip of fuse [1.5 mm dia. (0.059 in. dia.), 5 to 7 mm long (0.197 to 0.276 in. long)] on the piston head at three positions with grease so as to avoid the intake and exhaust valves and the combustion chamber ports.
3. Lower the piston, and install the cylinder head and tighten the cylinder head screws to the specified torque.
4. Turn the crankshaft until the piston exceeds its top dead center.
5. Remove the cylinder head, and measure the thickness of the squeezed fuses.
6. If the measurement is not within the factory specifications, check the oil clearance between the crankpin and crankpin bearing and between the piston pin and small end bushing.

■ **NOTE**

- **After checking the top clearance, be sure to assemble the cylinder head with a new cylinder head gasket.**

Top clearance	Factory spec.	D722	0.50 to 0.70 mm 0.0197 to 0.0276 in.
		D905	0.55 to 0.70 mm 0.0217 to 0.276 in.

Tightening torque	Cylinder head screw	D722	37.2 to 42.1 N·m 3.8 to 4.3 kgf·m 28.0 to 31.7 ft-lbs
		D905	63.7 to 68.6 N·m 6.5 to 7.0 kgf·m 47.0 to 50.6 ft-lbs

(1) Fuse

W1051877

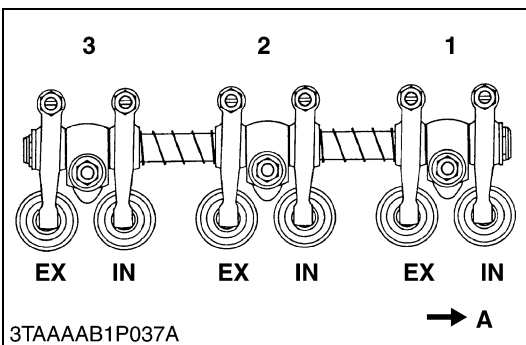
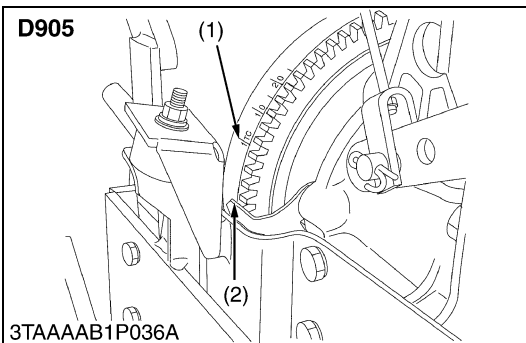
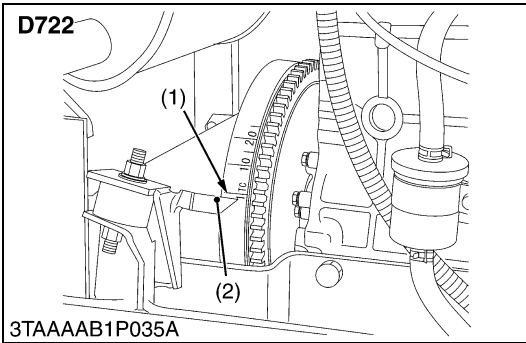
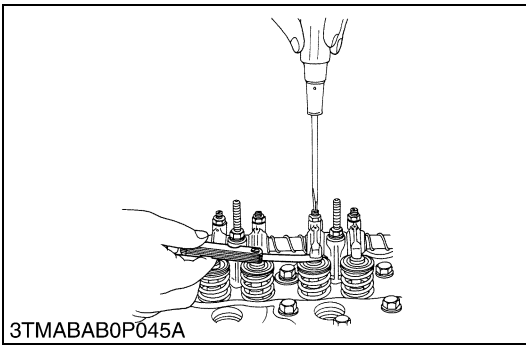

Valve Clearance

■ **IMPORTANT**

- The valve clearance must be checked and adjusted when engine is cold.

1. Remove the cylinder head cover and the glow plugs.
2. Align the “1TC” mark (1) on the flywheel and alignment mark (2) on the rear end plate so that the No. 1 piston comes to the compression top dead center.
3. Check the following valve clearance marked with “H” using a feeler gauge.

[When No. 1 piston is at the compression top dead center position]

Cylinder No.	No.1	No.2	No.3
Intake valve	H		H
Exhaust valve	H	H	

4. If the clearance is not within the factory specifications, adjust with the adjusting screw.
5. Then turn the flywheel 6.28 rad. (360 °), and align the “1TC” mark (1) on the flywheel and alignment mark (2) on the rear end plate so that the No.1 piston comes to the overlap position.
6. Check the following valve clearance marked with “I” using a feeler gauge.

[When No. 1 piston is at the overlap position]

Cylinder No.	No.1	No.2	No.3
Intake valve		I	
Exhaust valve			I

7. If the clearance is not within the factory specifications, adjust with the adjusting screw.

Intake and exhaust valve clearance (Cold)	Factory spec.	0.145 to 0.185 mm 0.00571 to 0.00728 in.
---	---------------	---

■ **NOTE**

- The sequence of cylinder numbers is given as No.1, No.2 and No.3 starting from the gear case side.
- After adjusting the valve clearance, secure the adjusting screw with the lock nut.

- (1) “1TC” Mark
(2) Alignment Mark

A : Gear Case Side

W10113200

(2) Disassembling and Assembling

(A) Cylinder Head and Valves

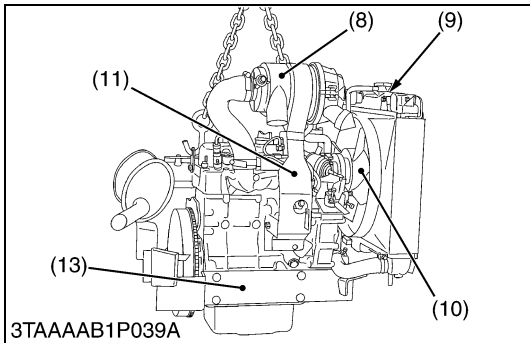
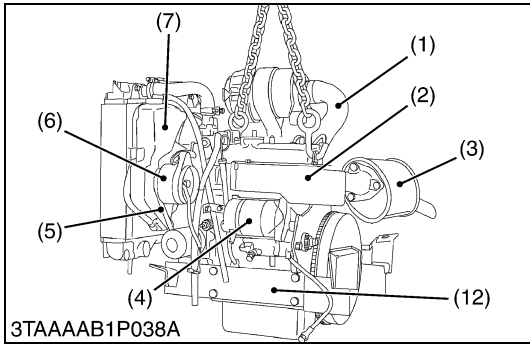

Alternator, Fan Belt and Muffler

1. Disconnect the radiator hoses and separate the radiator (9) with recovery tank (7) from engine assembly.
2. Remove the cooling fan (10) and fan pulley.
3. Remove the alternator (6) and fan belt (5).
4. Remove the muffler cover (2) and muffler (3).
5. Remove the starter (4).
6. Disconnect the inlet pipe (1), air cleaner (8) and air cleaner stay (11).
7. Remove the wire bracket.
8. Remove the engine support LH (12) and RH (13).

(When reassembling)

- Check to see that there are no cracks on the belt surface.

■ **IMPORTANT**

- **After reassembling the fan belt, be sure to adjust the fan belt tension.**

Tightening torque	Air cleaner stay nut	D722	23.5 to 27.5 N·m 2.4 to 2.8 kgf·m 17.4 to 20.3 ft-lbs
		D905	48.1 to 55.9 N·m 4.9 to 5.7 kgf·m 35.4 to 41.2 ft-lbs
	Engine support screw		48.1 to 55.9 N·m 4.9 to 5.7 kgf·m 35.4 to 41.2 ft-lbs

- | | |
|-------------------|------------------------|
| (1) Inlet Pipe | (8) Air Cleaner |
| (2) Muffler Cover | (9) Radiator |
| (3) Muffler | (10) Cooling Fan |
| (4) Starter | (11) Air Cleaner Stay |
| (5) Fan Belt | (12) Engine Support LH |
| (6) Alternator | (13) Engine Support RH |
| (7) Recovery Tank | |

W10192100

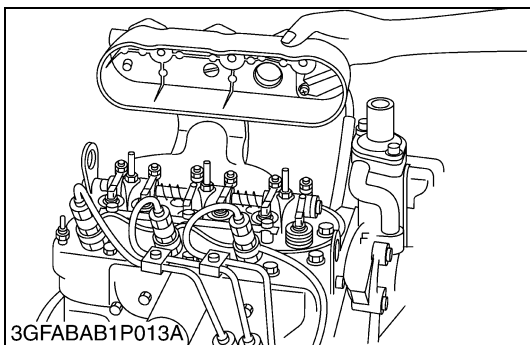

Cylinder Head Cover

1. Remove the head cover cap nuts.
2. Remove the cylinder head cover.

(When reassembling)

- Check to see if the cylinder head cover gasket is not defective.

Tightening torque	Cylinder head cover cap nut	D722	3.9 to 5.9 N·m 0.4 to 0.6 kgf·m 2.9 to 4.3 ft-lbs
		D905	6.9 to 8.8 N·m 0.7 to 0.9 kgf·m 5.1 to 6.5 ft-lbs

W1017302

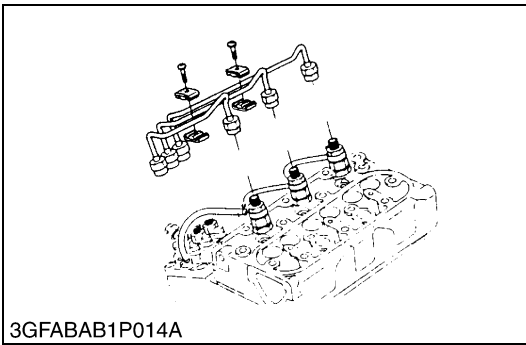

Injection Pipes

1. Loosen the screws on the pipe clamps.
2. Detach the injection pipes.

(When reassembling)

- Sent compressed air into the pipes to blow out dust. Then, reassemble the pipes in the reverse order.

Tightening torque	Injection pipe retaining nut	24.5 to 34.3 N·m
		2.5 to 3.5 kgf·m 18.1 to 25.3 ft-lbs

W1017424

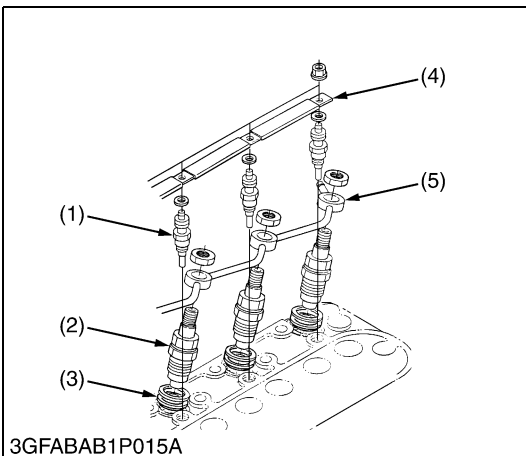

Nozzle Holder Assembly and Glow Plug

1. Remove the overflow pipe assembly (5).
2. Remove the nozzle holder assemblies (2).
3. Remove the copper gasket and heat seal (3).
4. Remove the lead (4) from the glow plugs.
5. Remove the glow plugs (1).

(When reassembling)

- Replace the copper gasket and heat seal with new one.

Tightening torque	Nozzle holder assembly	49.0 to 68.6 N·m 5.0 to 7.0 kgf·m 36.2 to 50.6 ft-lbs
	Overflow pipe assembly retaining nut	19.6 to 24.5 N·m 2.0 to 2.5 kgf·m 14.5 to 18.1 ft-lbs
	Glow plug	7.8 to 14.7 N·m 0.8 to 1.5 kgf·m 5.8 to 10.8 ft-lbs

- (1) Glow Plug (4) Lead
 (2) Nozzle Holder Assembly (5) Overflow Pipe Assembly
 (3) Heat Seal

W10198550

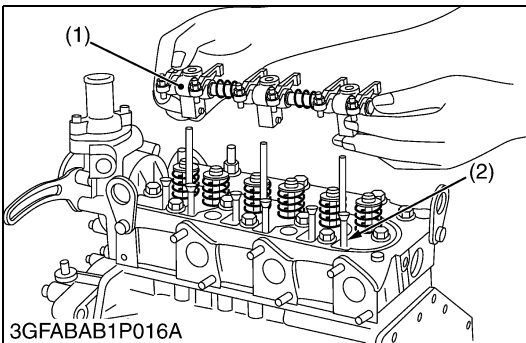

Rocker Arm and Push Rod

1. Remove the rocker arm bracket nuts.
2. Detach the rocker arm assembly (1).
3. Remove the push rods (2).

(When reassembling)

- When putting the push rods (2) onto the tappets (3), check to see if their ends are properly engaged with the grooves.

■ IMPORTANT

- **After installing the rocker arm, be sure to adjust the valve clearance.**

Tightening torque	Rocker arm bracket nut	D722	9.8 to 11.3 N·m 1.00 to 1.15 kgf·m 7.2 to 8.3 ft-lbs
		D905	21.6 to 26.5 N·m 2.2 to 2.7 kgf·m 15.9 to 19.5 ft-lbs

- (1) Rocker Arm Assembly (3) Tappet
 (2) Push Rod

W10203230

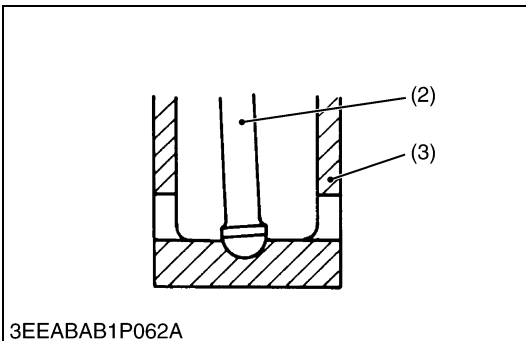

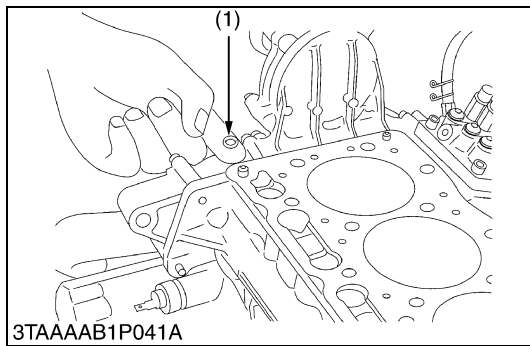
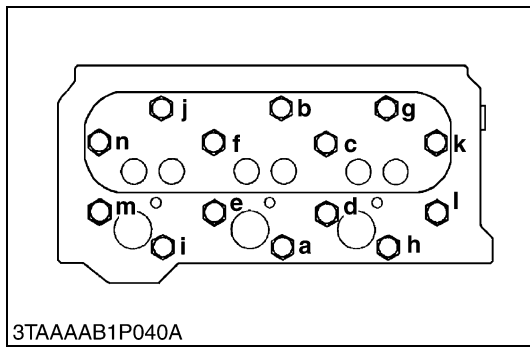

Cylinder Head

1. Loosen the pipe clamp, and remove the water return pipe.
2. Remove the cylinder head screw in the order of (n) to (a).
3. Lift up the cylinder head to detach.
4. Remove the cylinder head gasket and O-ring (1).

(When reassembling)

- Replace the cylinder head gasket with a new one.
- Securely fit the O-ring (1) to the pipe pin.
- Tighten the cylinder head screws after applying sufficient oil.
- Tighten the cylinder head screws diagonal sequence starting from the center.
- Tighten them uniformly, or the head may deform in the long run.
- Retighten the cylinder head screws after running the engine for 30 minutes.

Tightening torque	Cylinder head screw	D722	37.2 to 42.1 N·m 3.8 to 4.3 kgf·m 28.0 to 31.7 ft·lbs
		D905	63.7 to 68.6 N·m 6.5 to 7.0 kgf·m 47.0 to 50.6 ft·lbs

(n) to (a) : To Loosen
(a) to (n) : To Tighten

(1) O-ring

W10205250

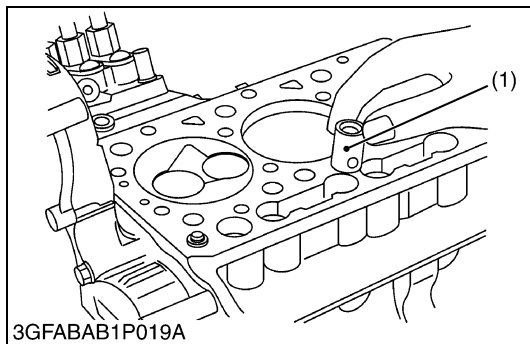

Tappets

1. Remove the tappets from the crankcase.

(When reassembling)

- Visually check the contact between tappets and cams for proper rotation. If defect is found, replace tappets.
- Before installing the tappets, apply engine oil thinly around them.

■ IMPORTANT

- **Do not change the combination of tappet and tappet guide.**

W10209700

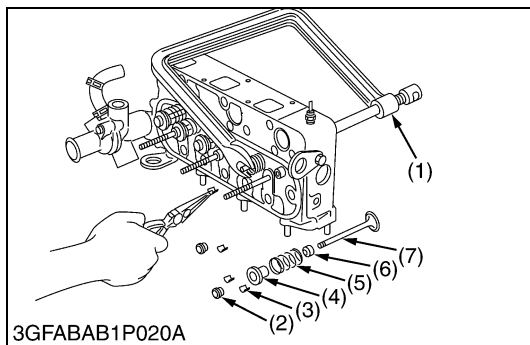

Valves

1. Remove the valve caps (2).
2. Remove the valve spring collet (3), pushing the valve spring retainer (4) by valve spring replacer (1).
3. Remove the valve spring retainer (4), valve spring (5) and valve stem seal (6).
4. Remove the valve (7).

(When reassembling)

- Wash the valve stem and valve guide hole, and apply engine oil sufficiently.
- After installing the valve spring collets, lightly tap the stem to assure proper fit with a plastic hammer.

■ IMPORTANT

- **Don't change the combination of valve and valve guide.**

- (1) Valve Spring Replacer
- (2) Valve Cap
- (3) Valve Spring Collet
- (4) Valve Spring Retainer

- (5) Valve Spring
- (6) Valve Stem Seal
- (7) Valve

W10211070

(B) Timing Gears, Camshaft and Fuel Camshaft [D722-E-BX]

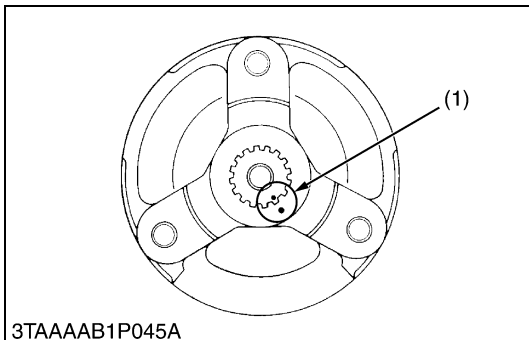
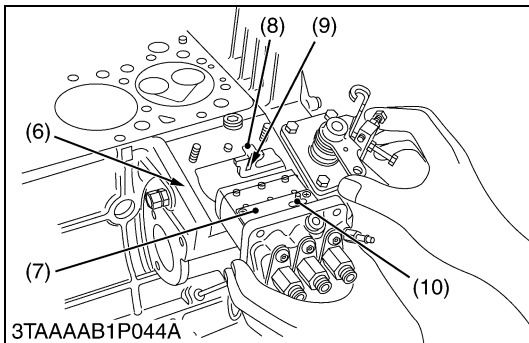
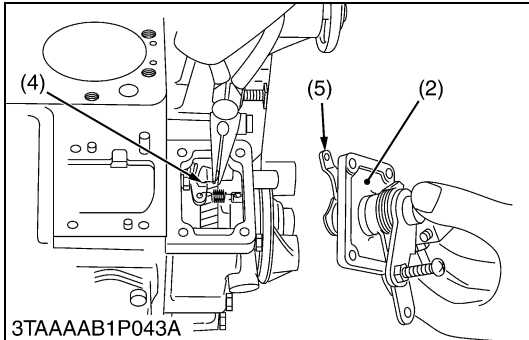
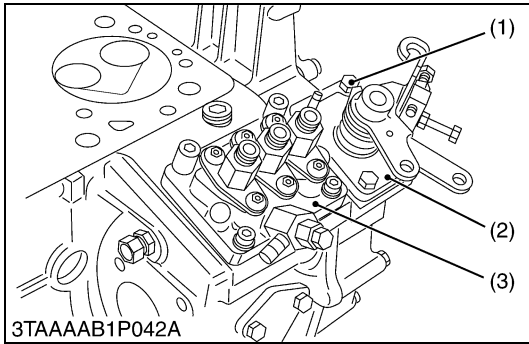

Injection Pump and Speed Control Plate

1. Remove the socket head screws and nuts, and remove the injection pump (3).
2. Remove the screws and separate the speed control plate (2), taking care not to damage the spring (4).
3. Disconnect the spring (4) and remove the speed control plate (2).

(When reassembling)

- Hook the spring (4) to the lever (5) first and install the speed control plate (2).
- Be sure to place the copper washers underneath two screws (1) (as shown in the figure).
- Position the slot (9) on the fork lever just under the slot (8) on the crankcase.
- Insert the injection pump (3) so that the control rod (7) should be pushed by the spring (6) at its end and the pin (10) on the rod engages with the slot (9) on the fork lever (as shown in the figure).

■ NOTE

- **The sealant is applied to both sides of the soft metal gasket shim. The liquid gasket is not required for assembling.**
- **Addition or reduction of shim (0.05 mm, 0.0020 in.) delays or advances the injection timing by approx. 0.0087 rad. (0.5 °).**
- **In disassembling and replacing, be sure to use the same number of new gasket shims with the same thickness.**

- | | |
|-------------------------------|----------------------------|
| (1) Screws and Copper Washers | (6) Spring |
| (2) Speed Control Plate | (7) Control Rod |
| (3) Injection Pump | (8) Slot (Crankcase Side) |
| (4) Spring | (9) Slot (Fork Lever Side) |
| (5) Lever | (10) Pin |

W1021176

Fan Drive Pulley

1. Set the stopper to the flywheel.
2. Remove the fan drive pulley screw.
3. Draw out the fan drive pulley with a puller.

(When reassembling)

- Install the pulley to the crankshaft, aligning the mark (1) on them.
- Apply engine oil to the fan drive pulley retaining screws. And tighten them.

Tightening torque	Fan drive pulley screw	117.6 to 127.4 N·m 12.0 to 13.0 kgf·m 86.8 to 94.0 ft-lbs
-------------------	------------------------	---

(1) Aligning Mark

W1022024

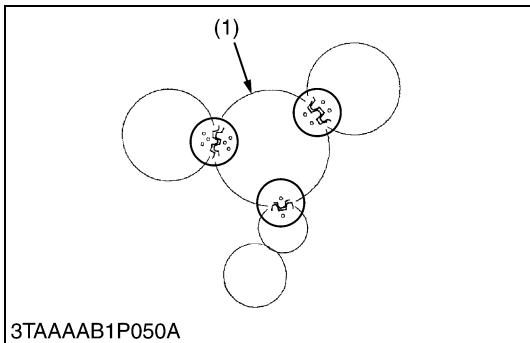
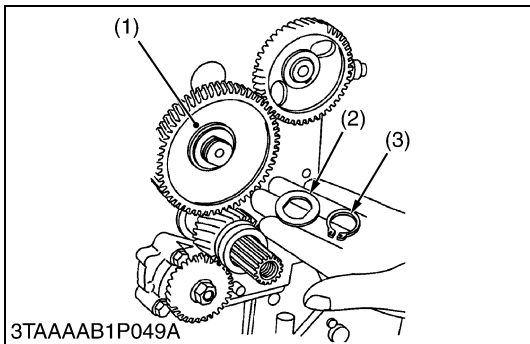
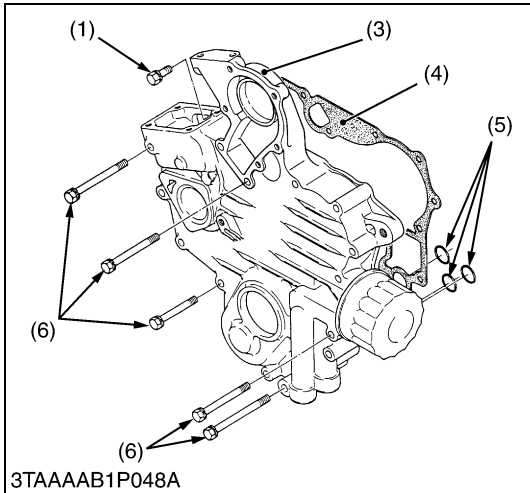
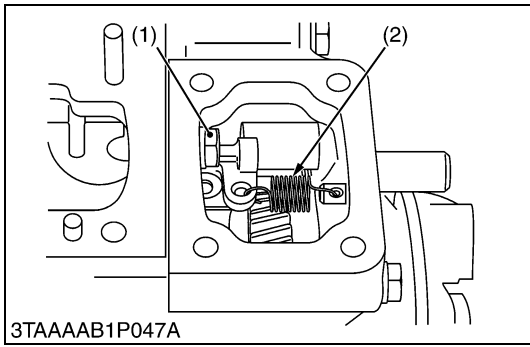

Gear Case

1. Remove the screw (1) of inside the gear case and outside screws.
2. Disconnect the start spring (2) in the speed control plate mounting hole.
3. Remove the gear case (3).

(When reassembling)

- Apply a liquid gasket (Three Bond 1215 or equivalent) to both sides of the gear case gasket (4).
- Be sure to set three O-rings (5) inside the gear case.

- | | |
|--------------------|----------------------|
| (1) Screw (Inside) | (4) Gear Case Gasket |
| (2) Start Spring | (5) O-ring |
| (3) Gear Case | (6) Screw |

W1023483

Idle Gear

1. Remove the external snap ring (3), the collar (2) and the idle gear (1).
2. Remove the idle gear shaft mounting screws.
3. Remove the idle gear shaft.

(When reassembling)

- Install the idle gear, aligning the mark on the gears referring to the figure.
- Apply engine oil to the idle gear shaft mounting screw. And tighten them.

Tightening torque	Idle gear shaft mounting screw	9.8 to 11.3 N·m 1.00 to 1.15 kgf·m 7.2 to 8.3 ft-lbs
-------------------	--------------------------------	--

- | | |
|----------------------|------------------------|
| (1) Idle Gear | (3) External Snap Ring |
| (2) Idle Gear Collar | |

W1023989

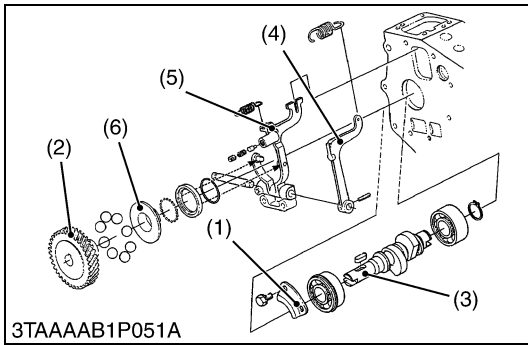

3TAAAAB1P051A

Fuel Camshaft

1. Remove the screws and draw out the camshaft with the gear on it.
2. Remove the retaining plate (1).
3. Remove the screws, then draw out the injection pump gear (2) and fuel camshaft (3) with the governor fork assembly.

(When reassembling)

- Hook the spring to the fork lever 2 (4) as shown in the figure before installing the fork lever assembly to the crankcase.

- | | |
|-------------------------|---------------------|
| (1) Retaining Plate | (4) Fork Lever 2 |
| (2) Injection Pump Gear | (5) Fork Lever 1 |
| (3) Fuel Camshaft | (6) Governor Sleeve |

W1024501

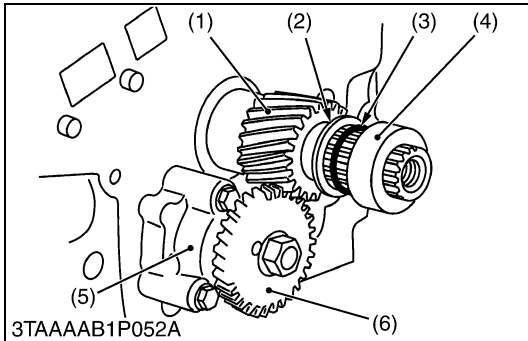

3TAAAAB1P052A

Oil Pump and Crankshaft Gear

1. Remove the oil pump gear (6).
2. Remove the oil pump (5).
3. Remove the collar (4), O-ring (3) and oil slinger (2).
4. Remove the crankshaft gear (1) with a puller.

(When reassembling)

- Install the collar after aligning the marks on the gears. (See the figure at "Idle Gear".)

- | | |
|----------------------------|-----------------------|
| (1) Crankshaft Gear | (4) Crankshaft Collar |
| (2) Crankshaft Oil Slinger | (5) Oil Pump |
| (3) O-ring | (6) Oil Pump Gear |

W1024761

(C) Timing Gears, Camshaft and Fuel Camshaft [D905-E-BX]

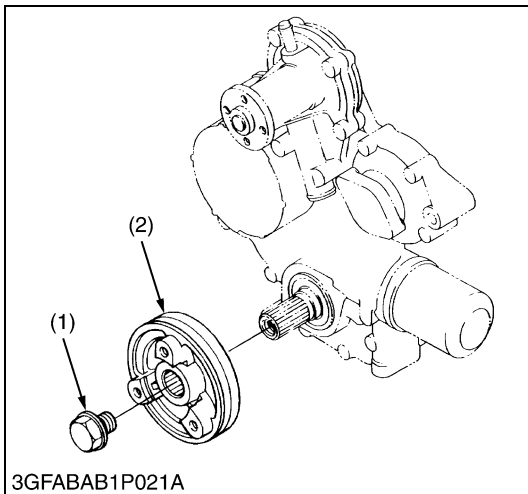

3GFABAB1P021A

Fan Drive Pulley

1. Set the stopper to the flywheel.
2. Remove the fan drive pulley screw (1).
3. Draw out the fan drive pulley (2) with a puller.

(When reassembling)

- Install the fan drive pulley to the crankshaft, aligning the marks (3) on them.

Tightening torque	Fan drive pulley screw	235.4 to 245.2 N·m 24.0 to 25.0 kgf·m 173.6 to 180.8 ft·lbs
-------------------	------------------------	---

- | | |
|----------------------------|-------------------|
| (1) Fan Drive Pulley Screw | (3) Aligning Mark |
| (2) Fan Drive Pulley | |

W10181950

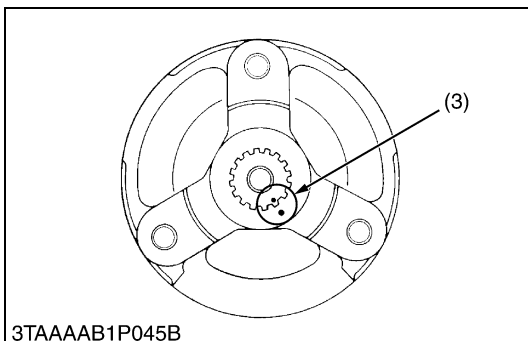

3TAAAAB1P045B

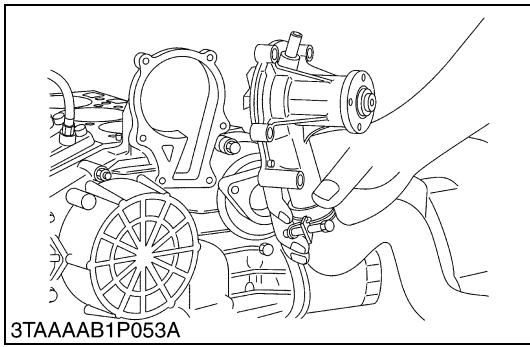

Water Pump

1. Remove the water pump flange.

(When reassembling)

- Before installing the water pump flange gasket, apply liquid gasket (Three Bond 1215 or equivalent) to the both side.

W1017530

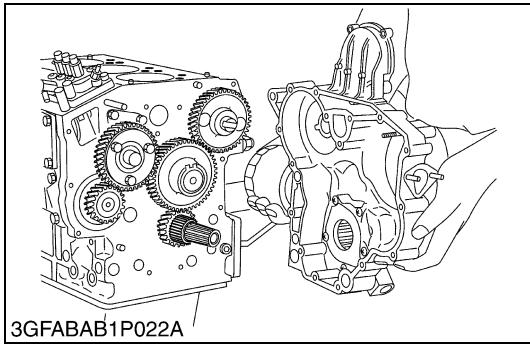

Gear Case

1. Remove the gear case.
2. Remove the crankshaft collar and O-rings.

(When reassembling)

- Replace the gear case gasket with a new one.
- Be sure to set four O-rings inside the gear case and the O-ring on the crankshaft.
- Apply a thin film of engine oil to the oil seal, and install it, noting the lip come off.
- Length of the gear case mounting screws. (Refer to the figure.)

A : 45 mm (1.77 in.)	E : 68 mm (2.68 in.)
B : 50 mm (1.97 in.)	F : 80 mm (3.15 in.)
C : 55 mm (2.17 in.)	G : Nut
D : 59 mm (2.32 in.)	

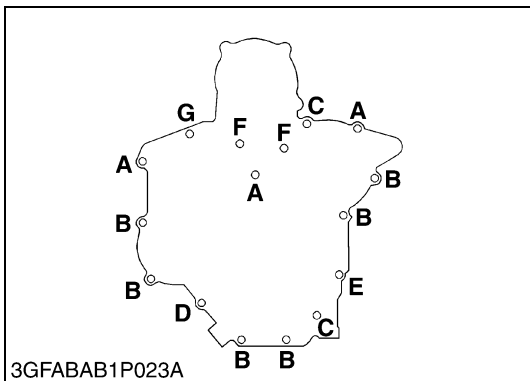

NOTE

- **Engine serial ranges : From 1U5494 (For all diesel engine 05 series)**
 - The four o-rings on the gear case of the engine have been removed, as the gear case gasket has been replaced with a metallic model.
 - **When you install a metallic gasket model,**
 1. Only use a new one.
 2. A liquid gasket is not necessary.

W10220030

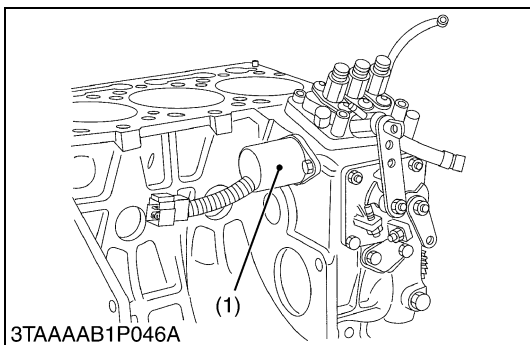

Engine Stop Solenoid

1. Remove the engine stop solenoid (1).

(When reassembling)

- Apply a thin coat of liquid-type gasket (Three bond 1215 or equivalent) to both surfaces of the solenoid's cover packing.
- Confirm the convex part of the flange of the engine stop solenoid has fitted into the hole, and then fasten the bolts.

(1) Engine Stop Solenoid

W1019085

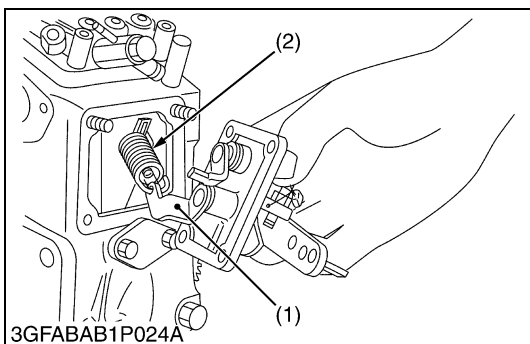

Speed Control Plate

1. Remove the speed control plate and governor lever (1) from the governor springs 1 (2).

(When reassembling)

- Securely catch the governor spring 1 and 2 on the governor lever as shown in the figure.
- Apply a liquid gasket (Three Bond 1215 or equivalent) to both sides of the speed control plate gasket.

(1) Governor Lever

(2) Governor Spring 1

W1018974

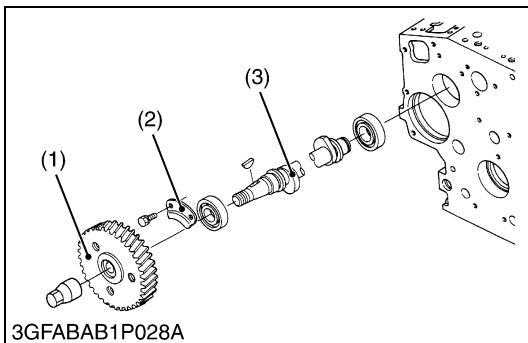
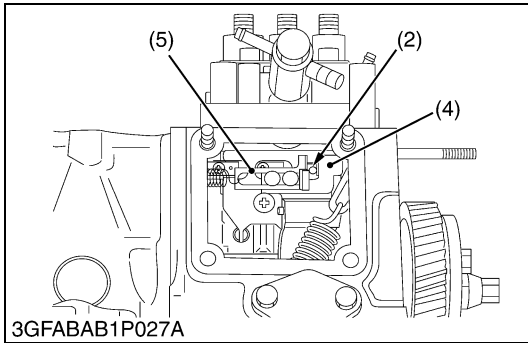
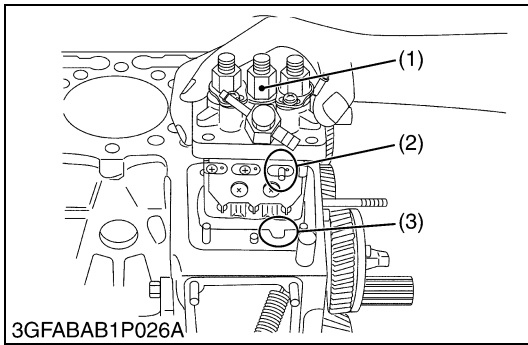

Injection Pump

1. Remove the injection pump mounting screws and nuts.
2. Align the control rack pin (2) with the notch (3) on the crankcase, then remove the injection pump (1).
3. Remove the injection pump timing shims.
4. In principle, the injection pump should not be disassembled.

(When reassembling)

- Securely fit the control rack pin (2) to the grooves of the fork lever 1 (4) and thrust lever (5).
- The sealant is applied to both sides of the shim (soft metal gasket shim). The liquid gasket is not required for assembling.
- Addition or reduction of shims (0.05 mm, 0.0020 in.) delays or advances the injection timing by approx. 0.0087 rad. (0.5 °).
- In disassembling and replacing, be sure to use the same number of new shims with the same thickness.

- | | |
|----------------------|------------------|
| (1) Injection Pump | (4) Fork Lever 1 |
| (2) Control Rack Pin | (5) Thrust Lever |
| (3) Notch | |

W10223180

Fuel Camshaft

1. Remove the fuel camshaft stopper (2).
2. Draw out the fuel camshaft (3) and injection pump gear (1).

(When reassembling)

- Apply engine oil thinly to the fuel camshaft before installation.

- | | |
|---------------------------|-------------------|
| (1) Injection Pump Gear | (3) Fuel Camshaft |
| (2) Fuel Camshaft Stopper | |

W1019366

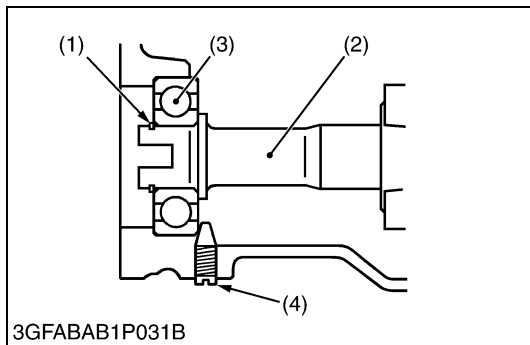
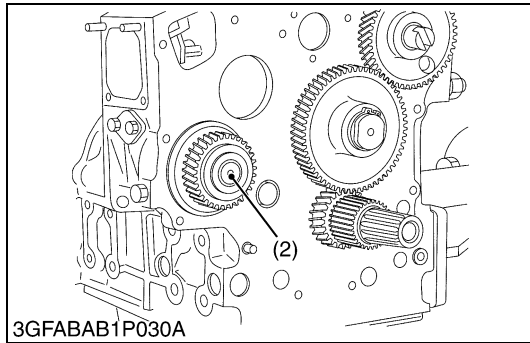
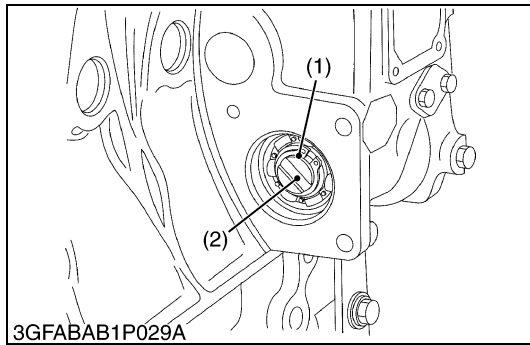

Governor Shaft

1. Remove the pump cover.
2. Remove the external snap ring (1) from the governor shaft (2).
3. Pull out the governor shaft (2).

(When reassembling)

- Make sure assembling the external snap ring of the governor shaft.
- Check the governor shaft for smooth rotation.

■ IMPORTANT

- **When replacing the ball bearing of governor shaft, securely fit the ball bearing (3) to the crankcase, apply an adhesive (Three Bond 1324B or equivalent) to the set screw (4), and fasten the screw until its tapered part contacts the circumferential end of the ball bearing.**

- | | |
|------------------------|------------------|
| (1) External Snap Ring | (3) Ball Bearing |
| (2) Governor Shaft | (4) Set Screw |

W10228020

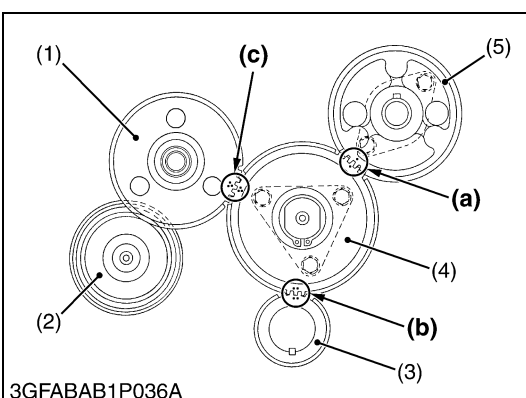
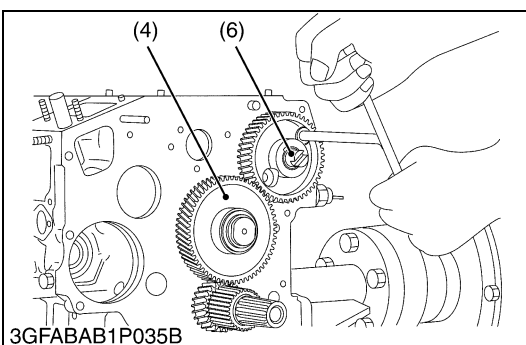
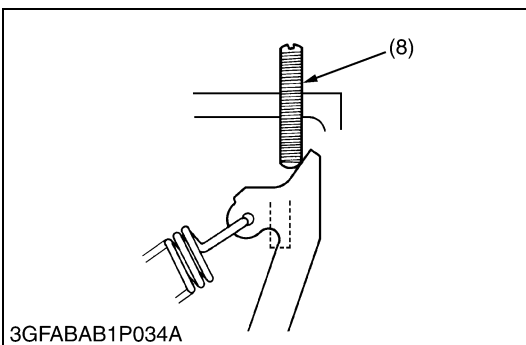
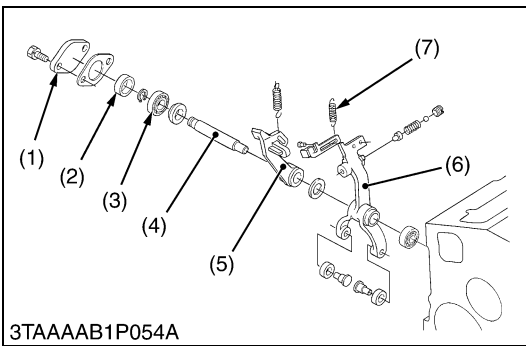
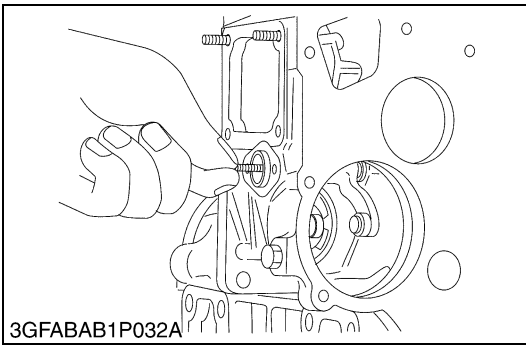

Fork Lever

1. Remove the start spring (7).
2. Remove the fork lever shaft cover (1).
3. Pull out the fork lever shaft (4), and remove the spacer (2), bearing (3), fork levers 1 (6) and 2 (5).

(When reassembling)

- Apply a liquid gasket (Three Bond 1215 or equivalent) to the both sides of the fork lever shaft cover, and fit the fork lever shaft cover with the “UP” mark facing upwards.
- Securely fit the start spring.

■ IMPORTANT

- **Install the fork lever 2 (5) to position it on the right side of the maximum output limit bolt (8) as shown in the figure.**

- | | |
|----------------------------|-------------------------------|
| (1) Fork Lever Shaft Cover | (5) Fork Lever 2 |
| (2) Spacer | (6) Fork Lever 1 |
| (3) Bearing | (7) Start Spring |
| (4) Fork Lever Shaft | (8) Maximum Output Limit Bolt |

W10230800

Camshaft and Idle Gear

1. Remove the external snap ring, and then remove the idle gear (4).
2. Remove the camshaft stopper mounting screw, and pull out the camshaft (6).

(When reassembling)

- When installing the idle gear, be sure to align the alignment marks (a), (b), (c) on the gears.
- Securely fit the external snap ring and stopper.

- | | |
|-------------------------|---|
| (1) Injection Pump Gear | (a) Alignment Mark
(Idle Gear and Cam Gear) |
| (2) Governor Gear | (b) Alignment Mark
(Idle Gear and Crank Gear) |
| (3) Crank Gear | (c) Alignment Mark
(Idle Gear and Injection Pump Gear) |
| (4) Idle Gear | |
| (5) Cam Gear | |
| (6) Crank Gear | |

W10234470

(D) Piston and Connecting Rod

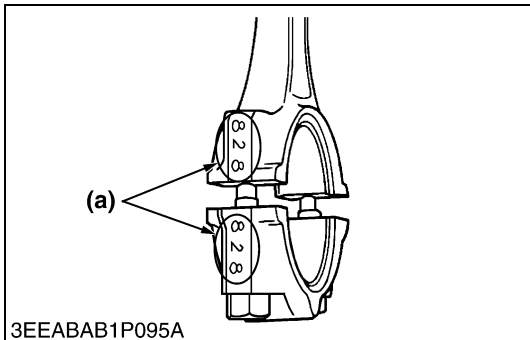
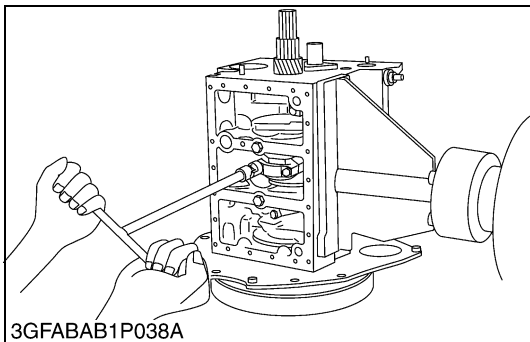
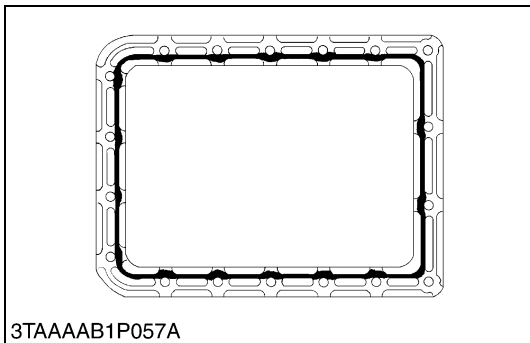
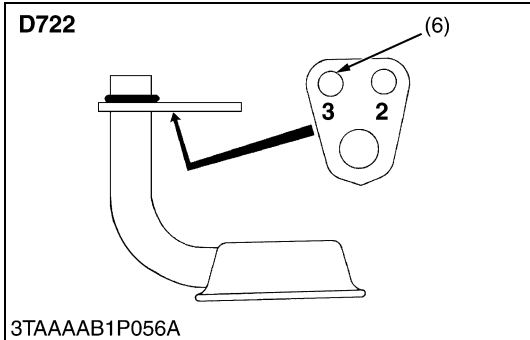
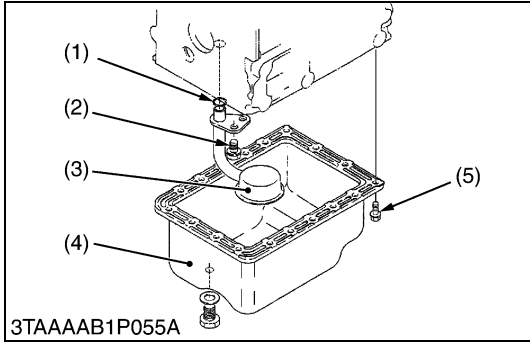

Oil Pan and Oil Strainer

1. Remove the oil pan mounting screws.
2. Remove the oil pan (4) by lightly tapping the rim of the pan with a wooden hammer.
3. Remove the oil strainer (3).

(When reassembling)

- After cleaning the oil strainer, check to see that the filter mesh is clean, and install it.
- Visually check the O-ring (1), apply engine oil, and install it.
- Securely fit the O-ring to the oil strainer.
- To avoid uneven tightening, tighten oil pan mounting screws in diagonal order from the center.
- Using the hole (6) numbered “3”, install the oil strainer by mounting screw. (D722 Only)

■ IMPORTANT

- **Scrape off the old adhesive completely. Wipe the sealing surface clean using waste cloth soaked with gasoline. Now apply new adhesive 3 to 5 mm (0.12 to 0.20 in.) thick all over the contact surface. Apply the adhesive also on the center of the flange as well as on the inner wall of each bolt hole.**
- **Cut the nozzle of the “liquid gasket” (Three Bond 1207D or equivalent) container at its second notch. Apply “liquid gasket” about 5 mm (0.20 in.) thick. Within 20 minutes after the application of fluid sealant, reassemble the components. Wait then for about 30 minutes, and pour oil in the crankcase.**

- | | |
|------------------|-----------------------------|
| (1) O-ring | (4) Oil Pan |
| (2) Screw | (5) Oil Pan Mounting Screws |
| (3) Oil Strainer | (6) Hole |

W10236610

Connecting Rod Cap

1. Remove the connecting rod caps.

(When reassembling)

- Align the marks (a) with each other. (Face the marks toward the injection pump.)
- Apply engine oil to the connecting rod screws and lightly screw it in by hand, then tighten it to the specified torque. If the connecting rod screw won't be screwed in smoothly, clean the threads. If the connecting rod screw is still hard to screw in, replace it.

Tightening torque	Connecting rod screw	D722	26.5 to 30.4 N·m 2.7 to 3.1 kgf·m 19.5 to 22.4 ft·lbs
		D905	41.2 to 46.1 N·m 4.2 to 4.7 kgf·m 30.3 to 33.9 ft·lbs

(a) Mark

W10242740

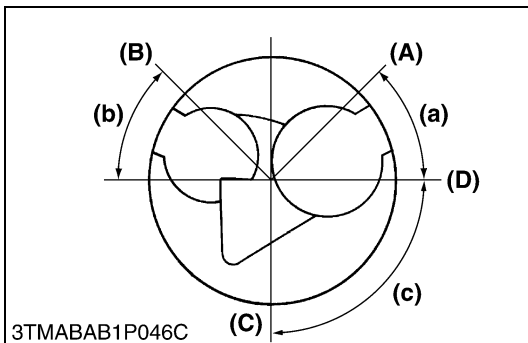
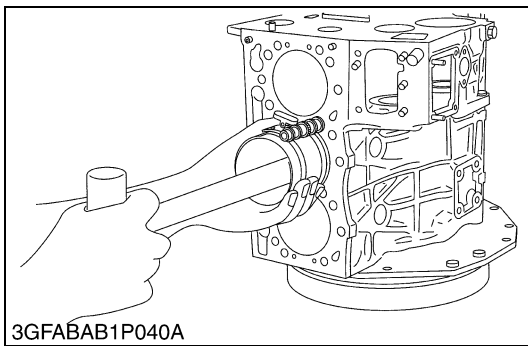
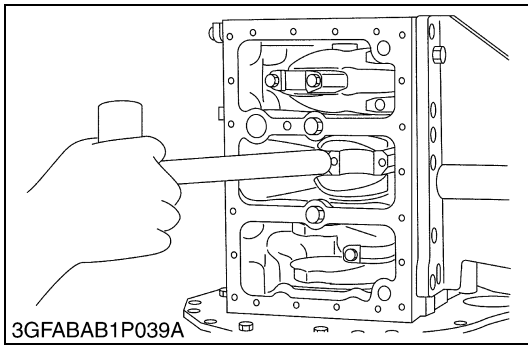

Pistons

1. Turn the flywheel and bring the piston to top dead center.
2. Draw out the piston upward by lightly tapping it from the bottom of the crankcase with the grip of a hammer.
3. Draw out the other piston in the same method as above.

(When reassembling)

- Before inserting the piston into the cylinder, apply enough engine oil to the piston.
- When inserting the piston into the cylinder, face the mark on the connecting rod to the injection pump.

■ IMPORTANT

- Do not change the combination of cylinder and piston. Make sure of the position of each piston by marking. For example, mark “1” on the No.1 piston.
- When installing the piston into the cylinder, place the gap of the compression ring 1 on the opposite side of the combustion chamber and stagger the gaps of the compression ring 2 and oil ring making a right angle from the gap of the compression ring 1.
- Carefully insert the pistons using a piston ring compressor. Otherwise, their chrome-plated section may be scratched, causing trouble inside the cylinder.

- | | |
|---------------------|---------------------|
| (A) Top Ring Gap | (a) 0.79 rad. (45°) |
| (B) Second Ring Gap | (b) 0.79 rad. (45°) |
| (C) Oil Ring Gap | (c) 1.57 rad. (90°) |
| (D) Piston Pin Hole | |

W10277450

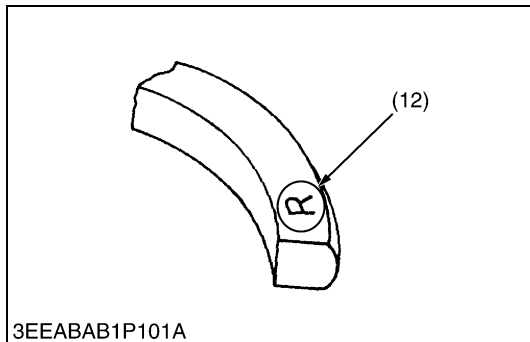
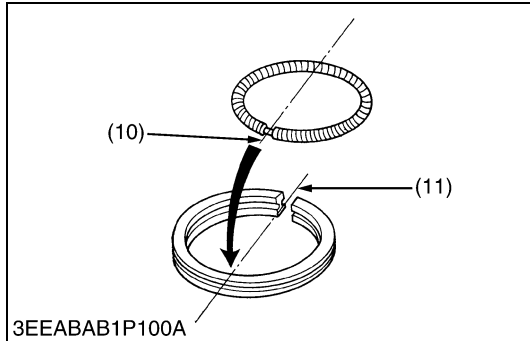
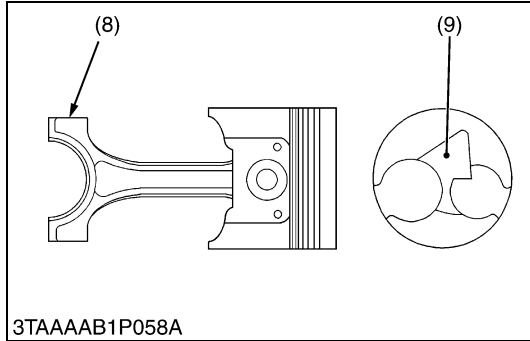
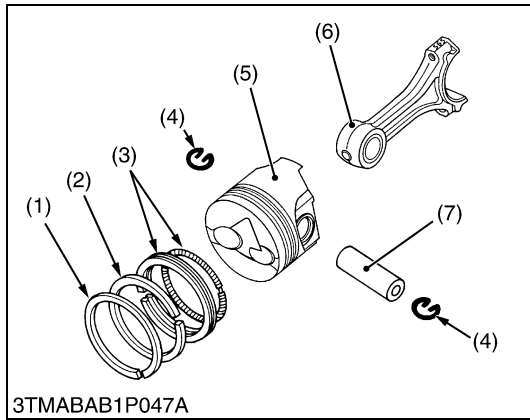

Piston Ring and Connecting Rod

1. Remove the piston rings using a piston ring tool (Code No. 07909-32121).
2. Remove the piston pin (7), and separate the connecting rod (6) from the piston (5).

(When reassembling)

- When installing the ring, assemble the rings so that the manufacturer's mark (12) near the gap faces the top of the piston.
- When installing the oil ring onto the piston, place the expander joint (10) on the opposite side of the oil ring gap (11).
- Apply engine oil to the piston pin.
- When installing the connecting rod to the piston, immerse the piston in 80 °C (176 °F) oil for 10 to 15 minutes and insert the piston pin to the piston.
- When installing the connecting rod to the piston, align the mark (8) on the connecting rod to the fan-shaped concave (9).

NOTE

- **Mark the same number on the connecting rod and the piston so as not to change the combination.**

- | | |
|--------------------------|---------------------------|
| (1) Top Ring | (7) Piston Pin |
| (2) Second Ring | (8) Alignment Number Mark |
| (3) Oil Ring | (9) Fan-Shaped Concave |
| (4) Piston Pin Snap Ring | (10) Expander Joint |
| (5) Piston | (11) Oil Ring Gap |
| (6) Connecting Rod | (12) Manufacturer's Mark |

W10281670

(E) Crankshaft

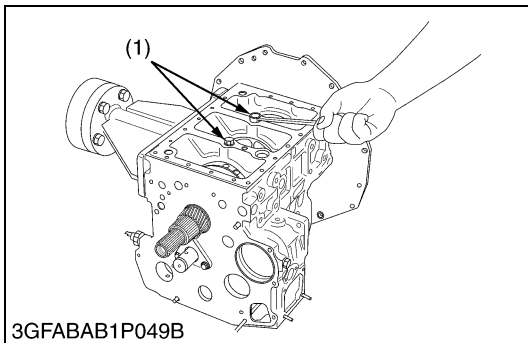
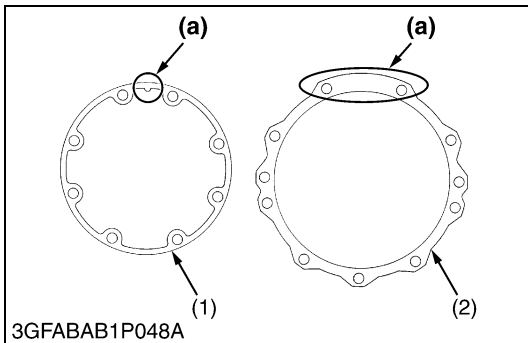
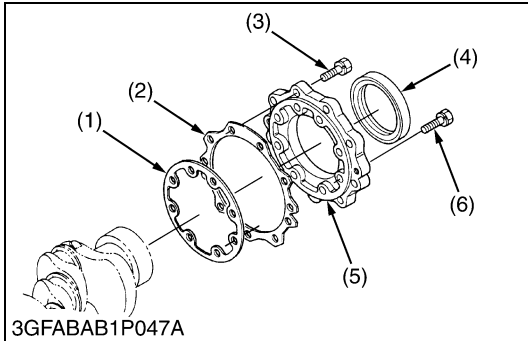
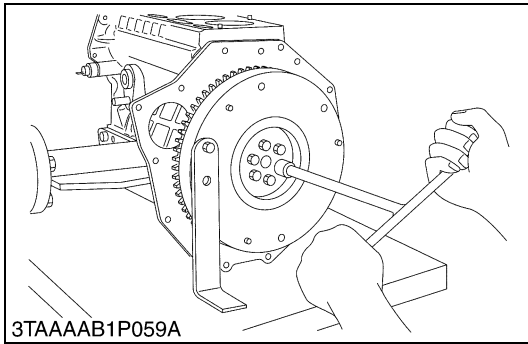

Flywheel

1. Fit the stopper to the flywheel.
2. Remove all flywheel screws and then remove the flywheel.

(When reassembling)

- Fit the flywheel giving care to the position of the knock pin.
- Apply engine oil to the threads and the undercut surface of the flywheel bolt and fit the bolt.

Tightening torque	Flywheel screw	53.9 to 58.8 N·m 5.5 to 6.0 kgf·m 39.8 to 43.4 ft-lbs
-------------------	----------------	---

W10290240

Bearing Case Cover

1. Remove the bearing case cover mounting screws. First, remove inside screws (6) and then outside screws (3).
2. Screw two removed screws into the screw hole of bearing case cover (5) to remove it.

(When reassembling)

- Fit the bearing case gasket (1) and the bearing case cover gasket (2) with correct directions.
- Install the bearing case cover to position the casting mark “UP” on it upward.
- Apply engine oil to the oil seal lip and take care that it is not rolled when installing.
- Tighten the bearing case cover mounting screws with even force on the diagonal line.

Tightening torque	Bearing case cover mounting screw	9.8 to 11.3 N·m 1.00 to 1.15 kgf·m 7.2 to 8.3 ft-lbs
-------------------	-----------------------------------	--

- (1) Bearing Case Gasket
- (2) Bearing Case Cover Gasket
- (3) Bearing Case Cover Mounting Screw
- (4) Oil Seal
- (5) Bearing Case Cover
- (6) Bearing Case Cover Mounting Screw
- (a) Upside

W10292140

Crankshaft Assembly

1. Remove the main bearing case screw 2 (1).
2. Pull out the crankshaft assembly.

■ IMPORTANT

- Take care to protect crankshaft bearing 1 from scratches, caused by the crank gear, etc.. (Wrap the gear in vinyl tape, etc.) (D905 only)

(When reassembling)

- Clean the oil passage of the crankshaft with compressed air.
- Apply oil to the main bearing case screw 2 (1).
- Install the crankshaft assembly, aligning the screw hole of main bearing case with the screw hole of crankcase.
- Clean the oil passage of the crankshaft with compressed air.

Tightening torque	Main bearing case screw 2	D722	26.5 to 30.4 N·m 2.7 to 3.1 kgf·m 19.5 to 22.4 ft-lbs
		D905	49.0 to 53.9 N·m 5.0 to 5.5 kgf·m 36.2 to 39.8 ft-lbs

- (1) Main Bearing Case Screw 2

W10295750

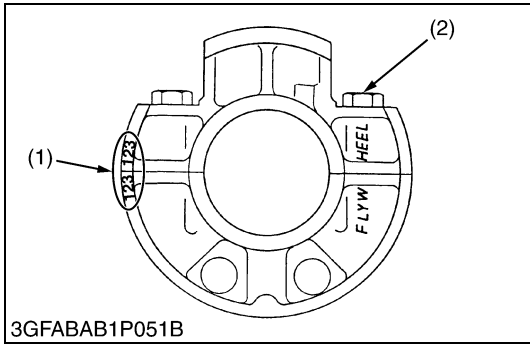
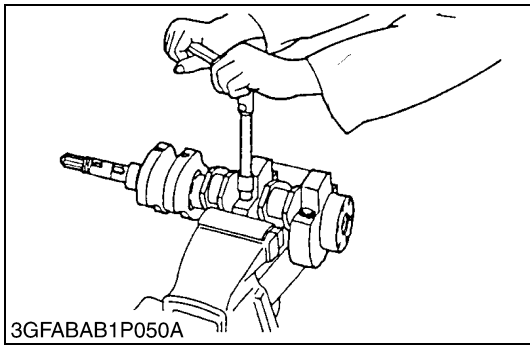

Main Bearing Case Assembly

1. Remove the two main bearing case screws 1, and remove the main bearing case assembly, being careful with thrust bearing and crankshaft bearing 2.
2. Remove the main bearing case assembly 1 and 2 as above.

(When reassembling)

- Clean the oil passage in the main bearing case.
- Apply clean engine oil on the bearings.
- Install the main bearing case assemblies in the original positions. Since diameters of main bearing cases vary, install them in order of markings **(A, B)** from the gear case side.
- Match the alignment numbers (1) on the main bearing case.
- When installing the main bearing case 1 and 2, face the mark **“FLYWHEEL”** to the flywheel.
- Install the thrust bearing with its oil groove facing outward.
- Confirm that the main bearing case moves smoothly after tightening the main bearing case screw 1 to the specified torque.

Tightening torque	Main bearing case screw 1	D722	23.6 to 27.4 N·m 2.4 to 2.8 kgf·m 17.4 to 20.2 ft·lbs
		D905	29.4 to 34.3 N·m 3.0 to 3.5 kgf·m 21.7 to 25.3 ft·lbs

(1) Alignment Number

(2) Main Bearing Case Screw 1

W1021927

(3) Servicing

(A) Cylinder Head and Valves

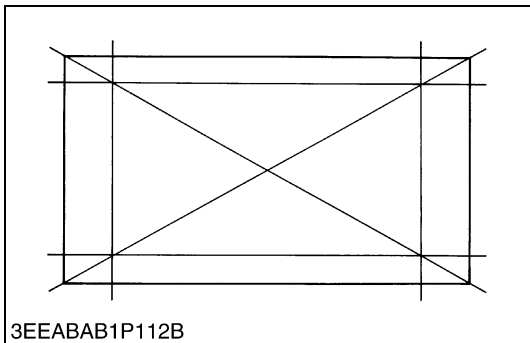
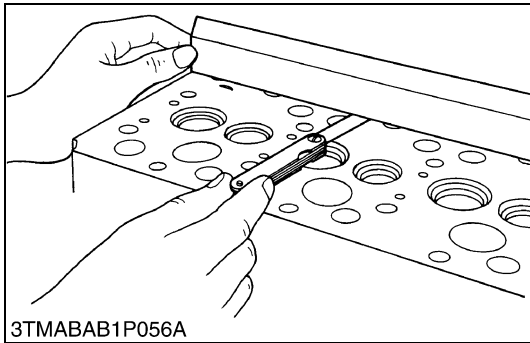

Cylinder Head Surface Flatness

1. Clean the cylinder head surface.
2. Place a straightedge on the cylinder head's four sides and two diagonal as shown in the figure.
3. Measure the clearance with a feeler gauge.
4. If the measurement exceeds the allowable limit, correct it with a surface grinder.

■ IMPORTANT

- **Do not place the straightedge on the combustion chamber.**
- **Be sure to check the valve recessing after correcting.**

Cylinder head surface flatness	Allowable limit	0.05 mm 0.0019 in.
--------------------------------	-----------------	-----------------------

W10277370

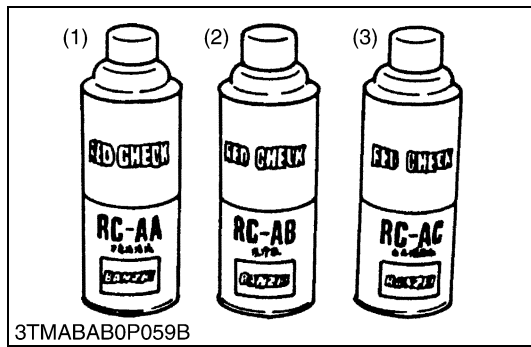

Cylinder Head Flaw

1. Prepare an air spray red check (Code No. 07909-31371).
2. Clean the surface of the cylinder head with detergent (2).
3. Spray the cylinder head surface with the read permeative liquid (1). Leave it five to ten minutes after spraying.
4. Wash away the read permeative liquid on the cylinder head surface with the detergent (2).
5. Spray the cylinder head surface with white developer (3).
6. If flawed, it can be identified as red marks.

- (1) Red Permeative Liquid (3) White Developer
(2) Detergent

W10765420

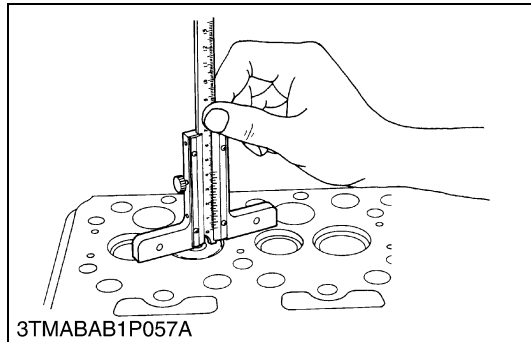

Valve Recessing

1. Clean the cylinder head surface, valve face and valve seat.
2. Insert the valve into the valve guide.
3. Measure the valve recessing with a depth gauge.
4. If the measurement exceeds the allowable limit, replace the valve.
5. If it still exceeds the allowable limit after replacing the valve, correct the valve seat face of the cylinder head with a valve seat cutter (Code No. 07909-33102) or valve seat grinder.
6. Then, correct the cylinder head surface with a surface grinder, or replace the cylinder head.

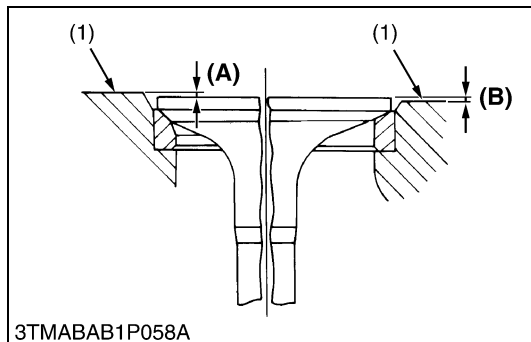

[D722]

Valve recessing	Factory spec.	0.10 (protrusion) to 0.10 (recessing) mm 0.0039 (protrusion) to 0.0039 (recessing) in.
	Allowable limit	0.30 (recessing) mm 0.0118 (recessing) in.

[D905]

Valve recessing	Factory spec.	0.05 (protrusion) to 0.15 (recessing) mm 0.0020 (protrusion) to 0.0059 (recessing) in.
	Allowable limit	0.40 (recessing) mm 0.0157 (recessing) in.

- (1) Cylinder Head Surface (A) Recessing
(B) Protrusion

W10768800

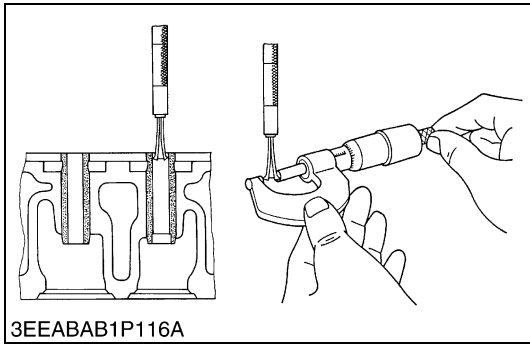
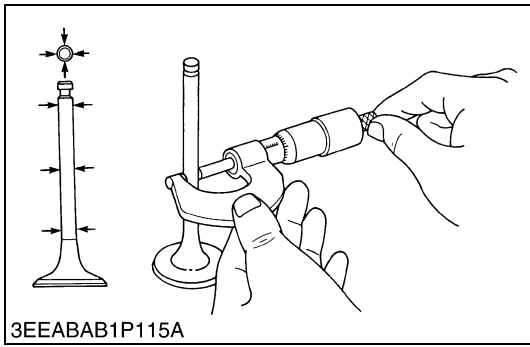

Clearance between Valve Stem and Valve Guide

1. Remove carbon from the valve guide section.
2. Measure the valve stem O.D. with an outside micrometer.
3. Measure the valve guide I.D. with a small hole gauge, and calculate the clearance.
4. If the clearance exceeds the allowable limit, replace the valves.
If it still exceeds the allowable limit, replace the valve guide.

[D722]

Clearance between valve stem and valve guide	Factory spec.	0.030 to 0.057 mm 0.00118 to 0.00224 in.
	Allowable limit	0.10 mm 0.0039 in.

Valve stem O.D.	Factory spec.	5.968 to 5.980 mm 0.23496 to 0.23543 in.
Valve guide I.D.	Factory spec.	6.010 to 6.025 mm 0.23661 to 0.23720 in.

[D905]

Clearance between valve stem and valve guide	Factory spec.	0.035 to 0.065 mm 0.00138 to 0.00256 in.
	Allowable limit	0.10 mm 0.0039 in.

Valve stem O.D.	Factory spec.	6.960 to 6.975 mm 0.27402 to 0.27461 in.
Valve guide I.D.	Factory spec.	7.010 to 7.025 mm 0.27599 to 0.27657 in.

W10774950

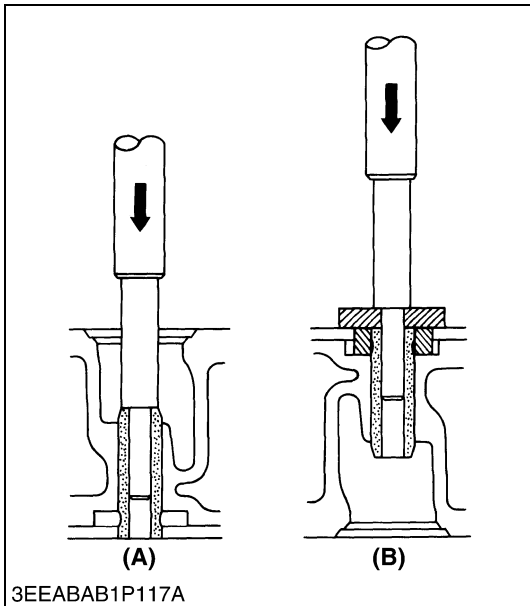

Replacing Valve Guide

(When removing)

1. Press out the used valve guide using a valve guide replacing tool.

(When installing)

1. Clean a new valve guide and valve guide bore, and apply engine oil to them.
2. Press in a new valve guide using a valve guide replacing tool.
3. Ream precisely the I.D. of the valve guide to the specified dimension.

Valve guide I.D. (Intake and exhaust)	Factory spec.	D722	6.010 to 6.025 mm 0.2366 to 0.2372 in.
		D905	7.010 to 7.025 mm 0.27598 to 0.27657 in.

■ IMPORTANT

- Do not hit the valve guide with a hammer during replacement.

(A) When Removing

(B) When Installing

W10278890

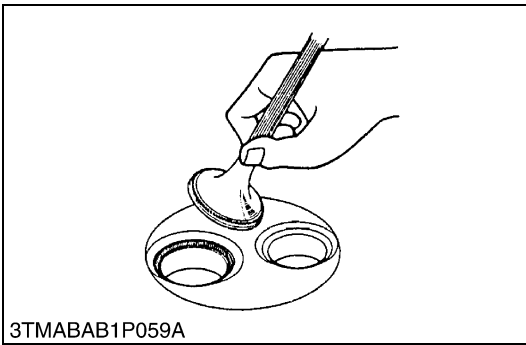

Valve Seating

1. Coat the valve face lightly with prussian blue and put the valve on its seat to check the contact.
2. If the valve does not seat all the way around the valve seat or the valve contact is less than 70 %, correct the valve seating as follows.
3. If the valve contact does not comply with the reference value, replace the valve or correct the contact of valve seating.

- (1) Correct (3) Incorrect
 (2) Incorrect

W10282190

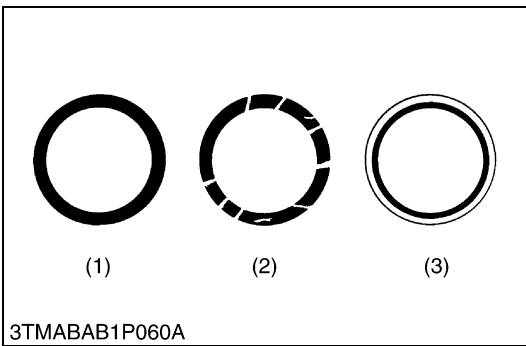

Correcting Valve and Valve Seat

■ **NOTE**

- Before correcting the valve and seat, check the valve stem and the I.D. of valve guide section, and repair them if necessary.
- After correcting the valve seat, be sure to check the valve recessing.

1) Correcting Valve

1. Correct the valve with a valve refacer.

2) Correcting Valve Seat

1. Slightly correct the seat surface with seat cutter (Code No. 07909-33102).

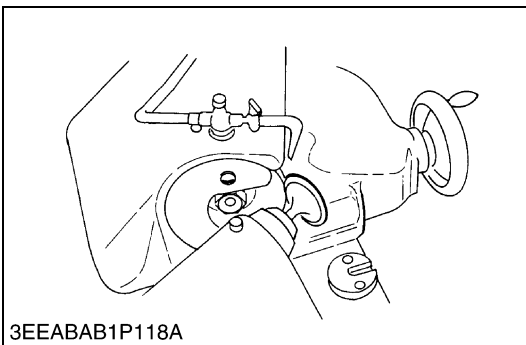

	D722	D905
Intake Valve	0.785 rad. 45 °	1.047 rad. 60 °
Exhaust Valve	0.785 rad. 45 °	0.785 rad. 45 °

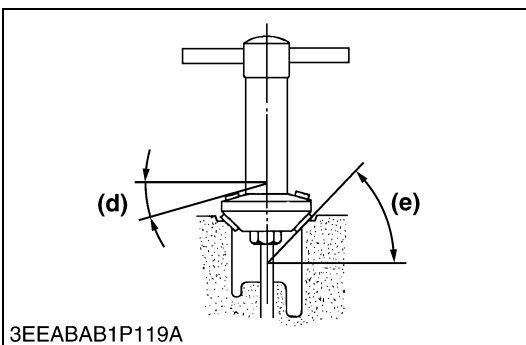

2. Resurface the seat surface with a 0.523 rad. (30 °) valve seat cutter to intake valve seat and with a 0.262 rad. (15 °) valve seat cutter to exhaust valve seat so that the width is close to specified valve seat width (2.12 mm, 0.0835 in.)

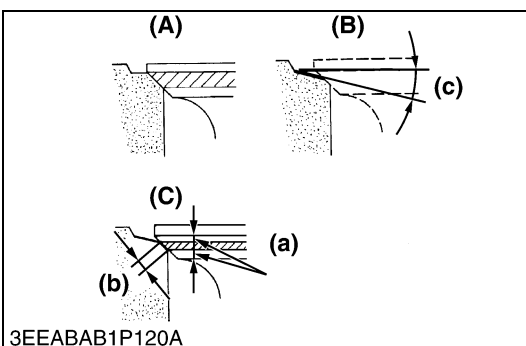

3. After resurfacing the seat, inspect for even valve seating, apply a thin film of compound between the valve face and valve seat, and fit them with valve lapping tool.
4. Check the valve seating with prussian blue. The valve seating surface should show good contact all the way around.

- (a) Identical Dimensions (A) Check Correct
 (b) Valve Seat Width (B) Correct Seat Width
 (c) 0.523 rad. (30 °) or 0.262 rad. (15 °) (C) Check Contact
 (d) 0.262 rad. (15 °) or 0.523 rad. (30 °)
 (e) 0.785 rad. (45 °) or 1.047 rad. (60 °)

W10283500

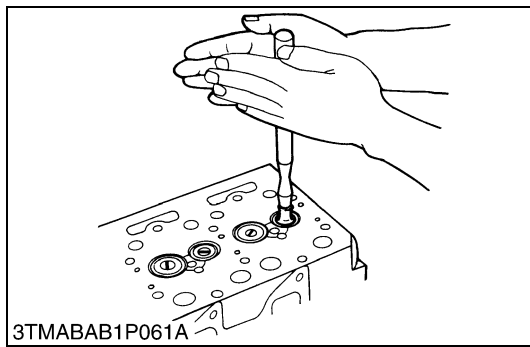

Valve Lapping

1. Apply compound evenly to the valve lapping surface.
2. Insert the valve into the valve guide. Lap the valve onto its seat with a valve flapper or screwdriver.
3. After lapping the valve, wash the compound away and apply oil, then repeat valve lapping with oil.
4. Apply prussian blue to the contact surface to check the seated rate. If it is less than 70 %, repeat valve lapping again.

■ IMPORTANT

- **When valve lapping is performed, be sure to check the valve recessing and adjust the valve clearance after assembling the valve.**

W10288140

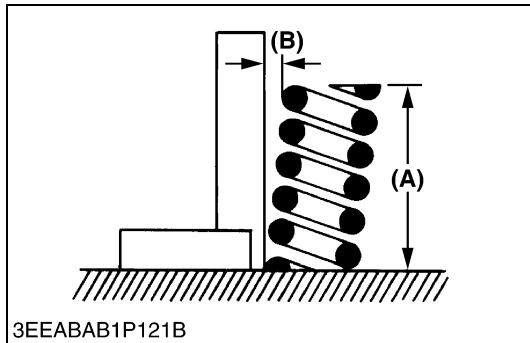

Free Length and Tilt of Valve Spring

1. Measure the free length **(A)** of valve spring with vernier calipers. If the measurement is less than the allowable limit, replace it.
2. Put the valve spring on a surface plate, place a square on the side of the valve spring.
3. Check to see if the entire side is in contact with the square. Rotate the valve spring and measure the maximum tilt **(B)**. Check the entire surface of the valve spring for scratches. If there is any defect, replace it.

[D722]

Free length (A)	Factory spec.	31.3 to 31.8 mm 1.232 to 1.252 in.
	Allowable limit	28.4 mm 1.118 in.
Tilt (B)	Allowable limit	1.2 mm 0.047 in.

[D905]

Free length (A)	Factory spec.	37.0 to 37.5 mm 1.457 to 1.476 in.
	Allowable limit	36.5 mm 1.437 in.
Tilt (B)	Allowable limit	1.0 mm 0.039 in.

W10289350

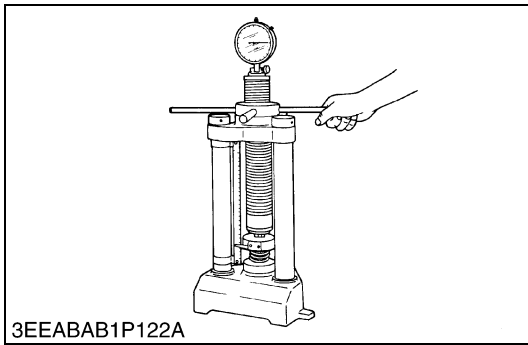

3EEABAB1P122A

Valve Spring Setting Load

1. Place the valve spring on a tester and compress it to the same length it is actually compressed in the engine.
2. Read the compression load on the gauge.
3. If the measurement is less than the allowable limit, replace it.

[D722]

Setting load / Setting length	Factory spec.	64.7 N / 27.0 mm 6.6 kgf / 27.0 mm 14.6 lbs / 1.063 in.
	Allowable limit	54.9 N / 27.0 mm 5.6 kgf / 27.0 mm 12.3 lbs / 1.063 in.

[D905]

Setting load / Setting length	Factory spec.	117.6 N / 31.0 mm 12.0 kgf / 31.0 mm 26.4 lbs / 1.220 in.
	Allowable limit	100.0 N / 31.0 mm 10.2 kgf / 31.0 mm 22.5 lbs / 1.220 in.

W10784360

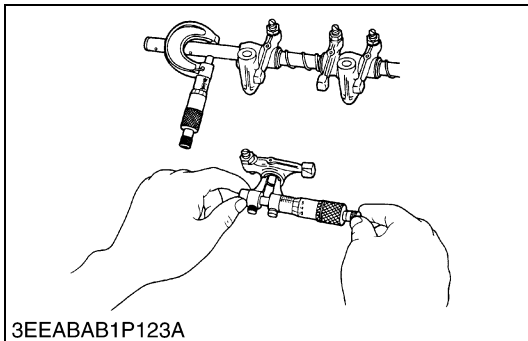

3EEABAB1P123A

Oil Clearance between Rocker Arm and Rocker Arm Shaft

1. Measure the rocker arm shaft O.D. with an outside micrometer.
2. Measure the rocker arm I.D. with an inside micrometer, and then calculate the oil clearance.
3. If the oil clearance exceeds the allowable limit, replace the rocker arm and measure the oil clearance again. If it still exceeds the allowable limit, replace also the rocker arm shaft.

[D722]

Oil clearance between rocker arm and rocker arm shaft	Factory spec.	0.016 to 0.045 mm 0.00063 to 0.00177 in.
	Allowable limit	0.15 mm 0.0059 in.

Rocker arm shaft O.D.	Factory spec.	10.473 to 10.484 mm 0.41232 to 0.41276 in.
Rocker arm I.D.	Factory spec.	10.500 to 10.518 mm 0.41339 to 0.41410 in.

[D905]

Oil clearance between rocker arm and rocker arm shaft	Factory spec.	0.016 to 0.045 mm 0.00063 to 0.00177 in.
	Allowable limit	0.10 mm 0.0039 in.

Rocker arm shaft O.D.	Factory spec.	11.973 to 11.984 mm 0.47138 to 0.47181 in.
Rocker arm I.D.	Factory spec.	12.000 to 12.018 mm 0.47244 to 0.47315 in.

W10291500

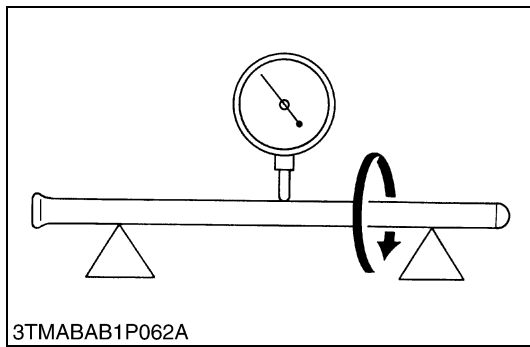

Push Rod Alignment

1. Place the push rod on V blocks.
2. Measure the push rod alignment.
3. If the measurement exceeds the allowable limit, replace the push rod.

Push rod alignment	Allowable limit	0.25 mm 0.0098 in.
--------------------	-----------------	-----------------------

W10292900

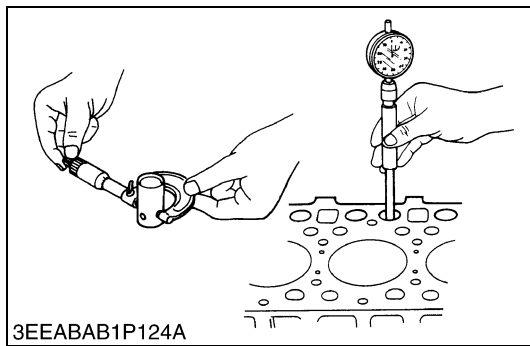

Oil Clearance between Tappet and Tappet Guide Bore

1. Measure the tappet O.D. with an outside micrometer.
2. Measure the I.D. of the tappet guide bore with a cylinder gauge, and calculate the oil clearance.
3. If the oil clearance exceeds the allowable limit or the tappet is damaged, replace the tappet.

[D722]

Oil Clearance between tappet and tappet guide bore	Factory spec.	0.016 to 0.052 mm 0.00063 to 0.00205 in.
	Allowable limit	0.10 mm 0.0039 in.

Tappet O.D.	Factory spec.	17.966 to 17.984 mm 0.70732 to 0.70803 in.
-------------	---------------	---

Tappet guide bore I.D.	Factory spec.	18.000 to 18.018 mm 0.70866 to 0.70937 in.
------------------------	---------------	---

[D905]

Oil Clearance between tappet and tappet guide bore	Factory spec.	0.020 to 0.062 mm 0.00079 to 0.00244 in.
	Allowable limit	0.07 mm 0.0028 in.

Tappet O.D.	Factory spec.	19.959 to 19.980 mm 0.78579 to 0.78661 in.
-------------	---------------	---

Tappet guide bore I.D.	Factory spec.	20.000 to 20.021 mm 0.78740 to 0.78823 in.
------------------------	---------------	---

W10293660

(B) Timing Gears, Camshaft and Fuel Camshaft

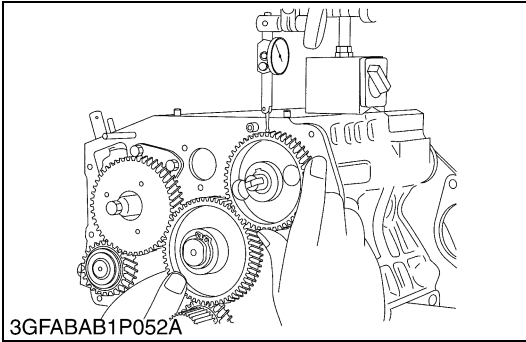

Timing Gear Backlash

1. Set a dial indicator (lever type) with its tip on the gear tooth.
2. Move the gear to measure the backlash, holding its mating gear.
3. If the backlash exceeds the allowable limit, check the oil clearance of the shafts and the gear.
4. If the oil clearance is proper, replace the gear.

[D722]

Backlash between idle gear and crank gear	Factory spec.	0.043 to 0.124 mm 0.00169 to 0.00488 in.
	Allowable limit	0.15 mm 0.0059 in.

Backlash between idle gear and cam gear	Factory spec.	0.047 to 0.123 mm 0.00185 to 0.00484 in.
	Allowable limit	0.15 mm 0.0059 in.

Backlash between idle gear and injection pump gear	Factory spec.	0.046 to 0.124 mm 0.00185 to 0.00488 in.
	Allowable limit	0.15 mm 0.0059 in.

Backlash between oil pump drive gear and crank gear	Factory spec.	0.041 to 0.123 mm 0.00161 to 0.00484 in.
	Allowable limit	0.15 mm 0.0059 in.

[D905]

Backlash between idle gear and crank gear	Factory spec.	0.032 to 0.115 mm 0.00120 to 0.00453 in.
	Allowable limit	0.15 mm 0.0059 in.

Backlash between idle gear and cam gear	Factory spec.	0.036 to 0.114 mm 0.00142 to 0.00449 in.
	Allowable limit	0.15 mm 0.0059 in.

Backlash between idle gear and injection pump gear	Factory spec.	0.034 to 0.116 mm 0.00134 to 0.00457 in.
	Allowable limit	0.15 mm 0.0059 in.

Backlash between injection pump gear and governor gear	Factory spec.	0.030 to 0.117 mm 0.00118 to 0.00461 in.
	Allowable limit	0.15 mm 0.0059 in.

W10280630

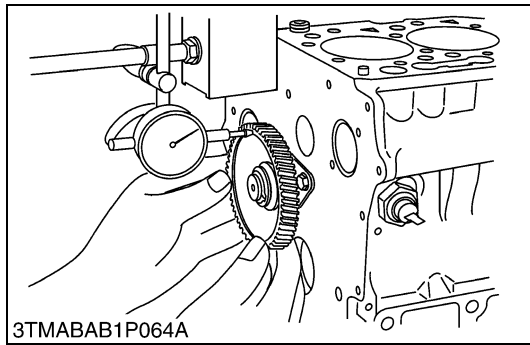

Idle Gear Side Clearance

1. Set a dial indicator with its tip on the idle gear.
2. Measure the side clearance by moving the idle gear to the front and rear.
3. If the measurement exceeds the allowable limit, replace the idle gear collar.

[D722]

Idle gear side clearance	Factory spec.	0.13 to 0.49 mm 0.0051 to 0.0199 in.
	Allowable limit	0.60 mm 0.0236 in.

[D905]

Idle gear side clearance	Factory spec.	0.20 to 0.51 mm 0.0079 to 0.0201 in.
	Allowable limit	0.80 mm 0.0315 in.

W10285590

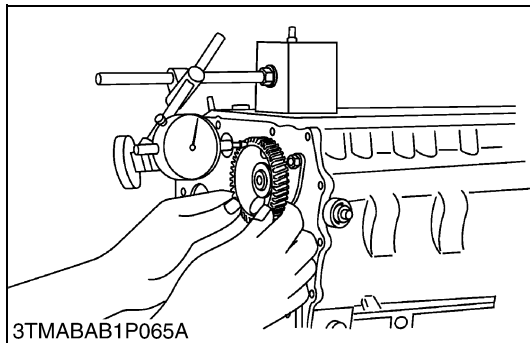

Camshaft Side Clearance

1. Set a dial indicator with its tip on the camshaft.
2. Measure the side clearance by moving the cam gear to the front to rear.
3. If the measurement exceeds the allowable limit, replace the camshaft stopper.

[D722]

Camshaft side clearance	Factory spec.	0.15 to 0.31 mm 0.0059 to 0.0122 in.
	Allowable limit	0.50 mm 0.0197 in.

[D905]

Camshaft side clearance	Factory spec.	0.07 to 0.22 mm 0.0028 to 0.0087 in.
	Allowable limit	0.30 mm 0.0118 in.

W10295630

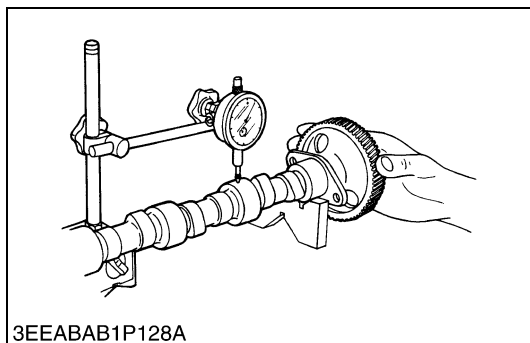

Camshaft Alignment

1. Support the camshaft with V blocks on the surface plate at both end journals.
2. Set a dial indicator with its tip on the intermediate journal.
3. Measure the camshaft alignment.
4. If the measurement exceeds the allowable limit, replace the camshaft.

Camshaft alignment	Allowable limit	0.01 mm 0.0004 in.
--------------------	-----------------	-----------------------

W10296710

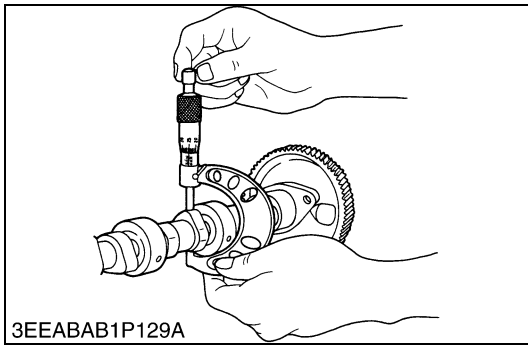

Cam Height

1. Measure the height of the cam at its highest point with an outside micrometer.
2. If the measurement is less than the allowable limit, replace the camshaft.

[D722]

Cam height of intake and exhaust	Factory spec.	26.88 mm 1.0583 in.
	Allowable limit	26.83 mm 1.0563 in.

[D905]

Cam height of intake	Factory spec.	28.80 mm 1.1339 in.
	Allowable limit	28.75 mm 1.1319 in.

Cam height of exhaust	Factory spec.	29.00 mm 1.1417 in.
	Allowable limit	28.95 mm 1.1398 in.

W10297880

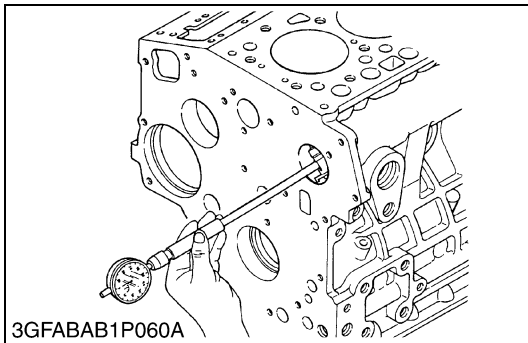

Oil Clearance of Camshaft Journal

1. Measure the camshaft journal O.D. with an outside micrometer.
2. Measure the cylinder block bore I.D. for camshaft with a cylinder gauge, and calculate the oil clearance.
3. If the oil clearance exceeds the allowable limit, replace the camshaft.

[D722]

Oil clearance of camshaft journal	Factory spec.	0.050 to 0.091 mm 0.00197 to 0.00358 in.
	Allowable limit	0.15 mm 0.0059 in.

Camshaft journal O.D.	Factory spec.	32.934 to 32.950 mm 1.29661 to 1.29724 in.
-----------------------	---------------	---

Camshaft Bearing I.D. (Cylinder block bore I.D.)	Factory spec.	33.000 to 33.025 mm 1.29921 to 1.30020 in.
---	---------------	---

[D905]

Oil clearance of camshaft journal	Factory spec.	0.050 to 0.091 mm 0.00197 to 0.00358 in.
	Allowable limit	0.15 mm 0.0059 in.

Camshaft journal O.D.	Factory spec.	35.934 to 35.950 mm 1.41472 to 1.41535 in.
-----------------------	---------------	---

Cylinder block bore I.D.	Factory spec.	36.000 to 36.025 mm 1.41732 to 1.41831 in.
--------------------------	---------------	---

W10299330

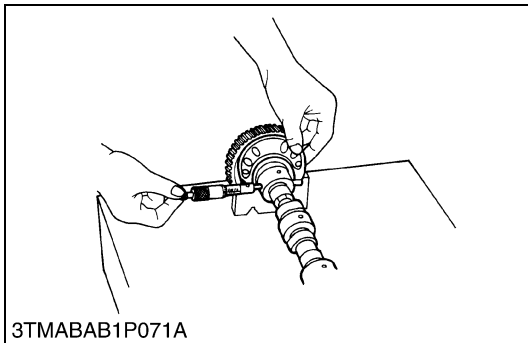

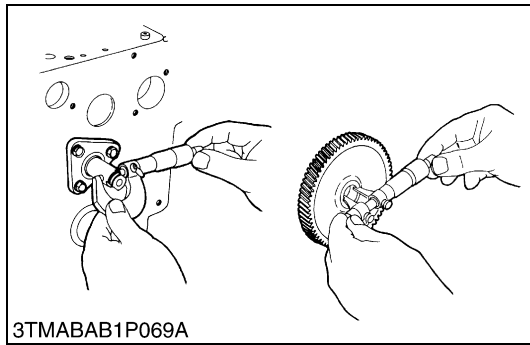

Oil Clearance between Idle Gear Shaft and Idle Gear Bushing

1. Measure the idle gear shaft O.D. with an outside micrometer.
2. Measure the idle gear bushing I.D. with an inside micrometer, and calculate the oil clearance.
3. If the oil clearance exceeds the allowable limit, replace the bushing.

If it still exceeds the allowable limit, replace the idle gear shaft.

[D722]

Oil clearance between idle gear shaft and idle gear bushing	Factory spec.	0.020 to 0.084 mm 0.00079 to 0.00331 in.
	Allowable limit	0.10 mm 0.0039 in.

Idle gear shaft O.D.	Factory spec.	19.967 to 19.980 mm 0.78610 to 0.78661 in.
Idle gear bushing I.D.	Factory spec.	20.000 to 20.051 mm 0.78740 to 0.78941 in.

[D905]

Oil clearance between idle gear shaft and idle gear bushing	Factory spec.	0.020 to 0.054 mm 0.00079 to 0.00213 in.
	Allowable limit	0.10 mm 0.0039 in.

Idle gear shaft O.D.	Factory spec.	25.967 to 25.980 mm 1.02232 to 1.02283 in.
Idle gear bushing I.D.	Factory spec.	26.000 to 26.021 mm 1.02362 to 1.02445 in.

W10301050

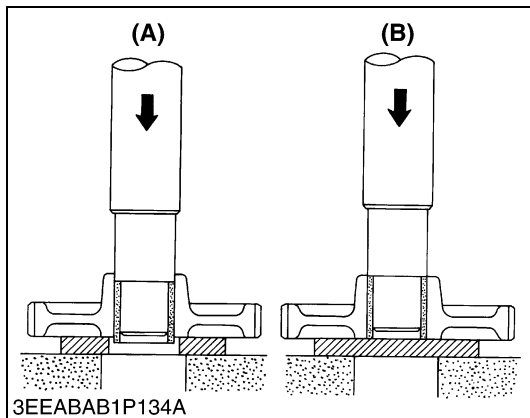

Replacing Idle Gear Bushing

(When removing)

1. Press out the used idle gear bushing using an idle gear bushing replacing tool.

(When installing)

1. Clean a new idle gear bushing and idle gear bore, and apply engine oil to them.
2. Press in a new bushing using an idle gear bushing replacing tool, until it is flush with the end of the idle gear.

(A) When Removing

(B) When Installing

W10302410

(C) Piston and Connecting Rod

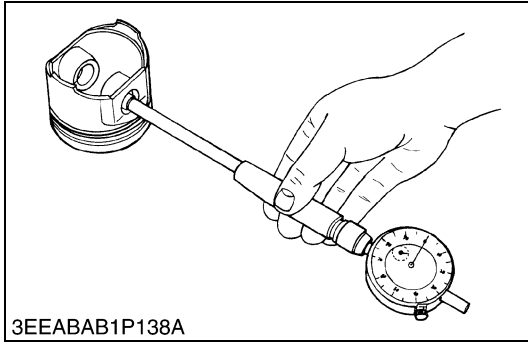

Piston Pin Bore I.D.

1. Measure the piston pin bore I.D. in both the horizontal and vertical directions with a cylinder gauge.
2. If the measurement exceeds the allowable limit, replace the piston.

[D722]

Piston pin bore I.D.	Factory spec.	20.000 to 20.013 mm 0.78740 to 0.78791 in.
	Allowable limit	20.05 mm 0.7894 in.

[D905]

Piston pin bore I.D.	Factory spec.	22.000 to 22.013 mm 0.86614 to 0.86665 in.
	Allowable limit	22.05 mm 0.8681 in.

W10304770

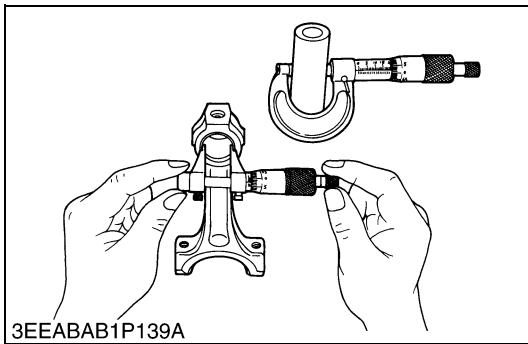

Oil Clearance between Piston Pin and Small End Bushing

1. Measure the piston pin O.D. where it contacts the bushing with an outside micrometer.
2. Measure the small end bushing I.D. with an inside micrometer, and calculate the oil clearance.
3. If the oil clearance exceeds the allowable limit, replace the bushing. If it still exceeds the allowable limit, replace the piston pin.

[D722]

Oil clearance between piston pin and small end bushing	Factory spec.	0.014 to 0.038 mm 0.00055 to 0.00150 in.
	Allowable limit	0.10 mm 0.0039 in.

Piston pin O.D.	Factory spec.	20.002 to 20.011 mm 0.78748 to 0.78783 in.
-----------------	---------------	---

Small end bushing I.D.	Factory spec.	20.025 to 20.040 mm 0.78839 to 0.78897 in.
------------------------	---------------	---

[D905]

Oil clearance between piston pin and small end bushing	Factory spec.	0.014 to 0.038 mm 0.00055 to 0.00150 in.
	Allowable limit	0.15 mm 0.0059 in.

Piston pin O.D.	Factory spec.	22.002 to 22.011 mm 0.86622 to 0.86657 in.
-----------------	---------------	---

Small end bushing I.D.	Factory spec.	22.025 to 22.040 mm 0.86713 to 0.86771 in.
------------------------	---------------	---

W10305740

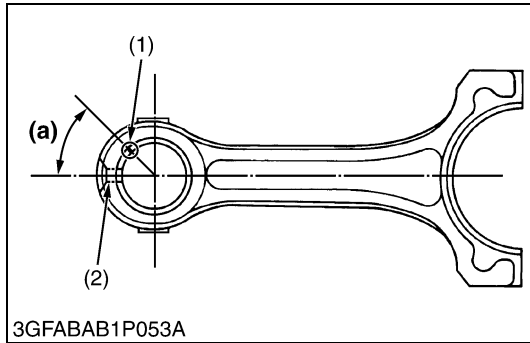
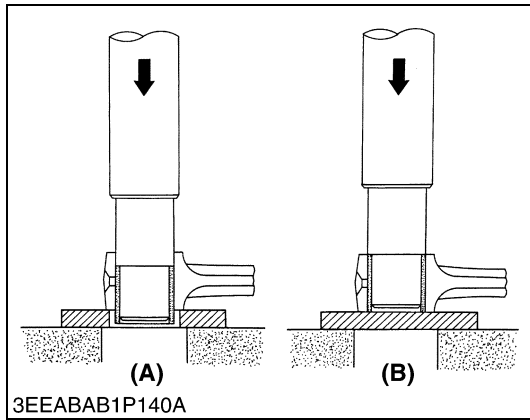

Replacing Small End Bushing

(When removing)

1. Press out the used bushing using a small end bushing replacing tool.

(When installing)

1. Clean a new small end bushing and bore, and apply engine oil to them.
2. Insert a new bushing onto the tool and press-fit it with a press so that the seam (1) of bushing positions as shown in the figure, until it is flush with the connecting rod.
3. Drill a hole to the bushing with aligning the oil hole (2) of connecting rod using 4.0 mm dia. (0.157 in. dia.) drill (D905 only).

NOTE

- Be sure to chamfer the oil hole circumference with an oil stone.

[D722]

Oil clearance between piston pin and small end bushing (Spare parts)	Factory spec.	0.015 to 0.075 mm 0.00059 to 0.00295 in.
	Allowable limit	0.15 mm 0.0059 in.

Small end bushing I.D. (Spare parts)	Factory spec.	20.026 to 20.077 mm 0.78842 to 0.79043 in.
--------------------------------------	---------------	---

[D905]

Oil clearance between piston pin and small end bushing (Spare parts)	Factory spec.	0.015 to 0.075 mm 0.00059 to 0.00295 in.
	Allowable limit	0.15 mm 0.0059 in.

Small end bushing I.D. (Spare parts)	Factory spec.	22.026 to 22.077 mm 0.86716 to 0.86917 in.
--------------------------------------	---------------	---

- (1) Seam
- (2) Oil Hole

- (A) When Removing**
- (B) When Installing**
- (a) 0.79 rad. (45 °)**

W10307120

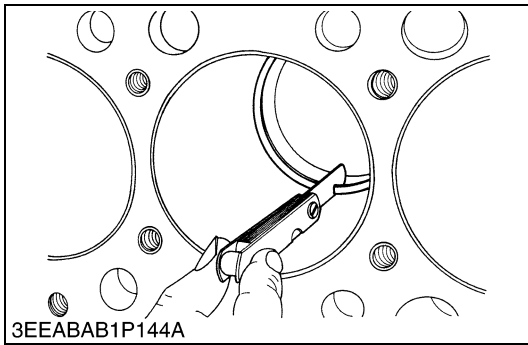

Piston Ring Gap

1. Insert the piston ring into the lower part of the cylinder (the least worn out part) with a piston ring compressor and piston.
2. Measure the ring gap with a feeler gauge.
3. If the measurement exceeds the allowable limit, replace the piston ring.

[D722]

Piston ring gap	Top ring Second ring	Factory spec.	0.25 to 0.40 mm 0.0098 to 0.0157 in.
		Allowable limit	1.25 mm 0.0492 in.
	Oil ring	Factory spec.	0.15 to 0.30 mm 0.0059 to 0.0118 in.
		Allowable limit	1.25 mm 0.0492 in.

[D905]

Piston ring gap	Top ring Second ring	Factory spec.	0.25 to 0.40 mm 0.0098 to 0.0157 in.
		Allowable limit	1.25 mm 0.0492 in.
	Oil ring	Factory spec.	0.25 to 0.45 mm 0.0098 to 0.0177 in.
		Allowable limit	1.25 mm 0.0492 in.

W10310120

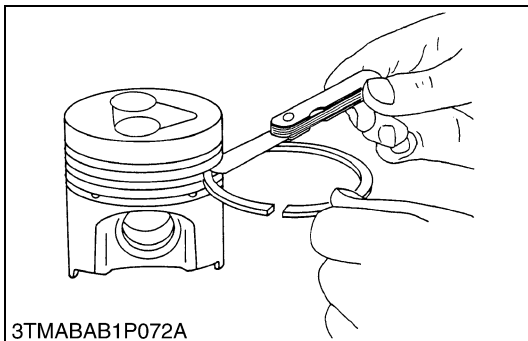

Clearance between Piston Ring and Piston Ring Groove

1. Clean the rings and the ring grooves, and install each ring in its groove.
2. Measure the clearance between the ring and the groove with a feeler gauge.
3. If the clearance exceeds the allowable limit, replace the piston ring.
4. If the clearance still exceeds the allowable limit with new ring, replace the piston.

[D722]

Clearance between piston ring and piston ring groove	Second ring	Factory spec.	0.090 to 0.120 mm 0.00354 to 0.00472 in.
		Allowable limit	0.15 mm 0.0059 in.
	Oil ring	Factory spec.	0.04 to 0.08 mm 0.0016 to 0.0031 in.
		Allowable limit	0.15 mm 0.0059 in.

[D905]

Clearance between piston ring and piston ring groove	Second ring	Factory spec.	0.085 to 0.112 mm 0.00335 to 0.00441 in.
		Allowable limit	0.20 mm 0.0079 in.
	Oil ring	Factory spec.	0.020 to 0.055 mm 0.00079 to 0.00217 in.
		Allowable limit	0.15 mm 0.0059 in.

W10312390

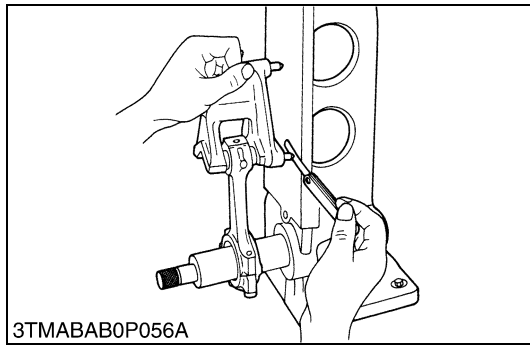

Connecting Rod Alignment

1. Remove the crankpin bearing, and install the connecting rod cap.
2. Install the piston pin in the connecting rod.
3. Install the connecting rod on the connecting rod alignment tool (Code No. 07909-31661).
4. Put a gauge over the piston pin, and move it against the face plate.
5. If the gauge does not fit squarely against the face plate, measure the space between the pin of the gauge and the face plate.
6. If the measurement exceeds the allowable limit, replace the connecting rod.

Space between gauge pin and face plate	Allowable limit	0.05 mm 0.0020 in.
--	-----------------	-----------------------

W10314620

(D) Crankshaft

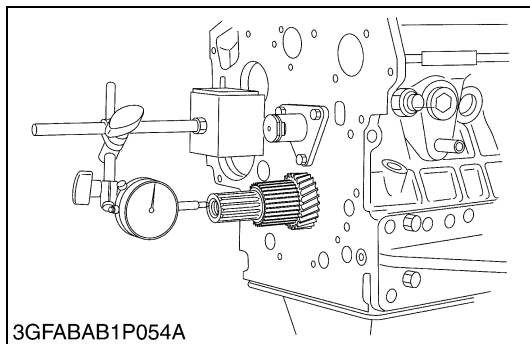

Crankshaft Side Clearance

1. Set a dial indicator with its tip on the end of the crankshaft.
2. Measure the side clearance by moving the crankshaft to the front and rear.
3. If the measurement exceeds the allowable limit, replace the thrust bearings.
4. If the same size bearing is useless because of the crankshaft journal wear, replace it with an oversize one referring to the table and figure.

Crankshaft side clearance	Factory spec.	0.15 to 0.31 mm 0.0059 to 0.0122 in.
	Allowable limit	0.50 mm 0.0197 in.

(Reference)

- Oversize thrust bearing

[D722]

Oversize	Bearing	Code Number	Marking
0.2 mm 0.008 in.	Thrust bearing 1 02	15261-23950	020 OS
	Thrust bearing 2 02	15261-23970	020 OS
0.4 mm 0.016 in.	Thrust bearing 1 04	15261-23960	040 OS
	Thrust bearing 2 04	15261-23980	040 OS

[D905]

Oversize	Bearing	Code Number	Marking
0.2 mm 0.008 in.	Thrust bearing 1 02	15521-23950	020 OS
	Thrust bearing 2 02	19202-23970	020 OS
0.4 mm 0.016 in.	Thrust bearing 1 04	15521-23960	040 OS
	Thrust bearing 2 04	19202-23980	040 OS

W10317070

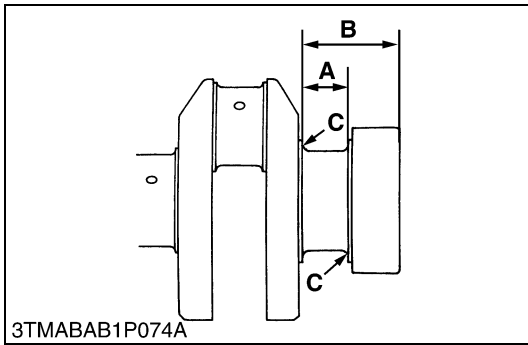

Crankshaft Side Clearance (Continued)

- Oversize dimensions of crankshaft journal
[D722]

Oversize	0.2 mm 0.008 in.	0.4 mm 0.016 in.
Dimension A	23.40 to 23.45 mm 0.9134 to 0.9154 in.	23.80 to 23.85 mm 0.9213 to 0.9232 in.
Dimension B	46.1 to 46.3 mm 1.815 to 1.823 in.	46.3 to 46.5 mm 1.823 to 1.831 in.
Dimension C	1.8 to 2.2 mm radius 0.071 to 0.087 in. radius	1.8 to 2.2 mm radius 0.071 to 0.087 in. radius

(0.8-S)

The crankshaft journal must be fine-finished to higher than ∇∇∇∇

[D905]

Oversize	0.2 mm 0.008 in.	0.4 mm 0.016 in.
Dimension A	28.20 to 28.25 mm 1.1102 to 1.1122 in.	28.40 to 28.45 mm 1.1181 to 1.1201 in.
Dimension B	51.5 to 51.7 mm 2.028 to 2.035 in.	51.6 to 51.8 mm 2.031 to 2.039 in.
Dimension C	2.3 to 2.7 mm radius 0.091 to 0.106 in. radius	2.3 to 2.7 mm radius 0.091 to 0.106 in. radius

(0.8-S)

The crankshaft journal must be fine-finished to higher than ∇∇∇∇

W1039207

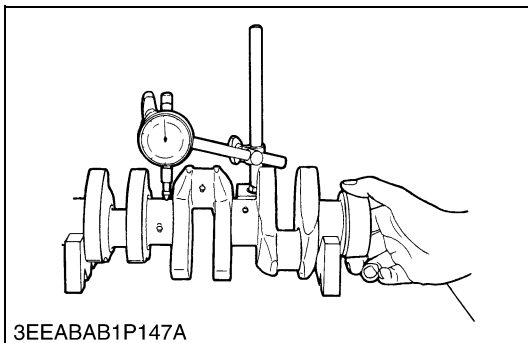

Crankshaft Alignment

1. Support the crankshaft with V blocks on the surface plate at both end journals.
2. Set a dial indicator with its tip on the intermediate journal.
3. Measure the crankshaft alignment.
4. If the measurement exceeds the allowable limit, replace the crankshaft.

Crankshaft alignment	Allowable limit	0.02 mm 0.0008 in.
----------------------	-----------------	-----------------------

W10330010

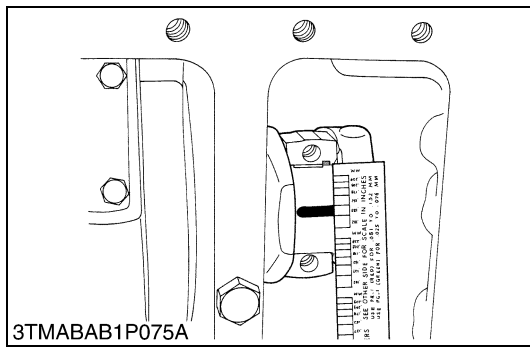

Oil Clearance between Crankpin and Crankpin Bearing

1. Clean the crankpin and crankpin bearing.
2. Put a strip of plastigage (Code No.: 07909-30241) on the center of the crankpin.
3. Install the connecting rod cap and tighten the connecting rod screws to the specified torque, and remove the cap again.
4. Measure the amount of the flattening with the scale, and get the oil clearance.
5. If the oil clearance exceeds the allowable limit, replace the crankpin bearing.
6. If the same size bearing is useless because of the crankpin wear, replace it with an undersize one referring to the table and figure.

NOTE

- **Never insert the plastigage into the crankpin oil hole.**
- **Be sure not to move the crankshaft while the connecting rod screws are tightened.**

[D722]

Oil clearance between crankpin and crankpin bearing	Factory spec.	0.020 to 0.051 mm 0.00079 to 0.00201 in.
	Allowable limit	0.15 mm 0.0059 in.
Crankpin O.D.	Factory spec.	33.959 to 33.975 mm 1.33697 to 1.33760 in.
Crankpin bearing I.D.	Factory spec.	33.995 to 34.010 mm 1.33839 to 1.33898 in.

[D905]

Oil clearance between crankpin and crankpin bearing	Factory spec.	0.029 to 0.091 mm 0.00114 to 0.00358 in.
	Allowable limit	0.20 mm 0.0079 in.
Crankpin O.D.	Factory spec.	39.959 to 39.975 mm 1.57319 to 1.57382 in.
Crankpin bearing I.D.	Factory spec.	40.004 to 40.050 mm 1.57496 to 1.57677 in.

W10331060

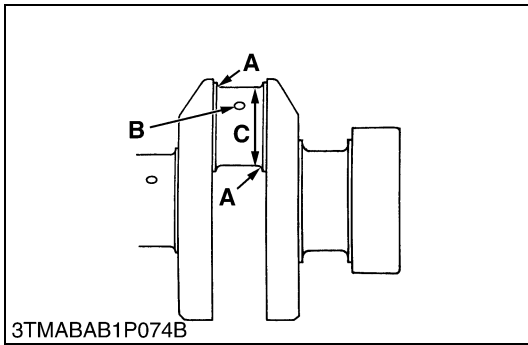

Oil Clearance between Crankpin and Crankpin Bearing (Continued)

(Reference)

- Undersize crankpin bearing

[D722]

Undersize	Bearing	Code Number	Marking
0.2 mm 0.008 in.	Crankpin bearing 02	15861-22970	020 US
0.4 mm 0.016 in.	Crankpin bearing 04	15861-22980	040 US

[D905]

Undersize	Bearing	Code Number	Marking
0.2 mm 0.008 in.	Crankpin bearing 02	16241-22970	020 US
0.4 mm 0.016 in.	Crankpin bearing 04	16241-22980	040 US

- Undersize dimensions of crankpin

[D722]

Undersize Dimension	0.2 mm 0.008 in.	0.4 mm 0.016 in.
	A	2.3 to 2.7 mm radius 0.091 to 0.106 in. radius
B	4 mm radius 0.16 in. radius	4 mm radius 0.16 in. radius
C	33.759 to 33.775 mm 1.32910 to 1.32973 in.	33.559 to 33.575 mm 1.32122 to 1.32185 in.
(0.8-S)		
The crankpin must be fine-finished to higher than ∇∇∇∇		

[D905]

Undersize Dimension	0.2 mm 0.008 in.	0.4 mm 0.016 in.
	A	2.8 to 3.2 mm radius 0.1102 to 0.1260 in. radius
B	1.0 to 1.5 mm radius 0.0394 to 0.0591 in. radius	1.0 to 1.5 mm radius 0.0394 to 0.0591 in. radius
C	39.759 to 39.775 mm 1.56531 to 1.56594 in.	39.559 to 39.575 mm 1.55744 to 1.55807 in.
(0.8-S)		
The crankpin must be fine-finished to higher than ∇∇∇∇		

W1039928

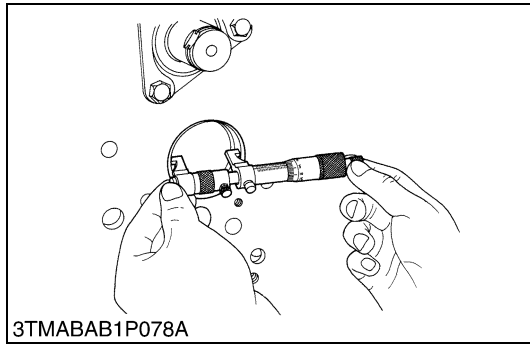
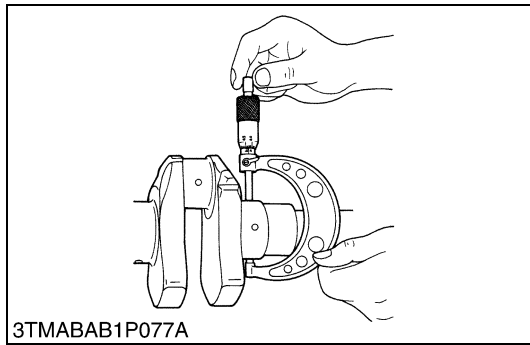

Oil Clearance between Crankshaft Journal and Crankshaft Bearing 1

1. Measure the O.D. of the crankshaft front journal with an outside micrometer.
2. Measure the I.D. of the crankshaft bearing 1 with an inside micrometer, and calculate the oil clearance.
3. If the oil clearance exceeds the allowable limit, replace the crankshaft bearing 1.
4. If the same size bearing is useless because of the crankshaft journal wear, replace it with an undersize one referring to the table and figure.

[D722]

Oil clearance between crankshaft journal and crankshaft bearing 1	Factory spec.	0.034 to 0.106 mm 0.00134 to 0.00417 in.
	Allowable limit	0.20 mm 0.0079 in.

Crankshaft journal O.D.	Factory spec.	39.934 to 39.950 mm 1.57221 to 1.57284 in.
Crankshaft bearing 1 I.D.	Factory spec.	39.984 to 40.040 mm 1.57417 to 1.57638 in.

[D905]

Oil clearance between crankshaft journal and crankshaft bearing 1	Factory spec.	0.034 to 0.114 mm 0.00134 to 0.00449 in.
	Allowable limit	0.20 mm 0.0079 in.

Crankshaft journal O.D.	Factory spec.	47.934 to 47.950 mm 1.88716 to 1.88779 in.
Crankshaft bearing 1 I.D.	Factory spec.	47.984 to 48.048 mm 1.88913 to 1.89165 in.

W10337170

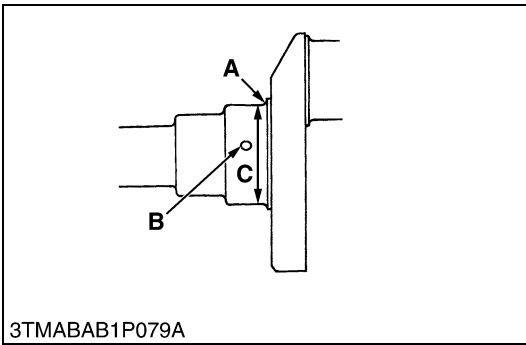

Oil Clearance between Crankshaft Journal and Crankshaft Bearing 1 (Continued)

(Reference)

- Undersize crankshaft bearing 1

[D722]

Undersize	Bearing	Code Number	Marking
0.2 mm 0.008 in.	Crankshaft bearing 1 02	15861-23910	020 US
0.4 mm 0.016 in.	Crankshaft bearing 1 04	15861-23920	040 US

[D905]

Undersize	Bearing	Code Number	Marking
0.2 mm 0.008 in.	Crankshaft bearing 1 02	16241-23910	020 US
0.4 mm 0.016 in.	Crankshaft bearing 1 04	16241-23920	040 US

- Undersize dimensions of crankshaft journal

[D722]

Undersize Dimension	0.2 mm 0.008 in.	0.4 mm 0.016 in.
	A	1.8 to 2.2 mm radius 0.071 to 0.087 in. radius
B	5 mm dia. 0.20 in. dia.	5 mm dia. 0.20 in. dia.
C	39.734 to 39.750 mm 1.56433 to 1.56496 in.	39.534 to 39.550 mm 1.55646 to 1.55709 in.
(0.8-S) The crankshaft journal must be fine-finished to higher than ∇∇∇∇		

[D905]

Undersize Dimension	0.2 mm 0.008 in.	0.4 mm 0.016 in.
	A	2.3 to 2.7 mm radius 0.0906 to 0.1063 in. radius
B	1.0 to 1.5 mm radius 0.0394 to 0.0591 in. radius	1.0 to 1.5 mm radius 0.0394 to 0.0591 in. radius
C	47.734 to 47.750 mm 1.87929 to 1.87992 in.	47.534 to 47.550 mm 1.87142 to 1.87204 in.
(0.8-S) The crankshaft journal must be fine-finished to higher than ∇∇∇∇		

W1041068

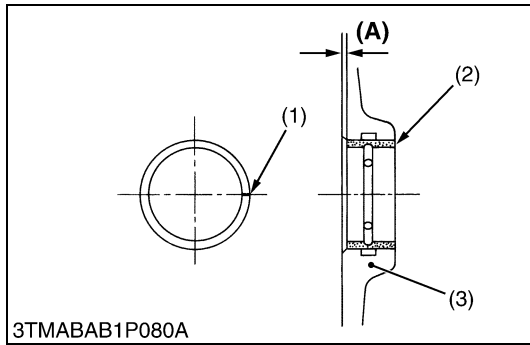

Replacing Crankshaft Bearing 1

(When removing)

1. Press out the used crankshaft bearing 1 using a crankshaft bearing 1 replacing tool.

(When installing)

1. Clean a new crankshaft bearing 1 and crankshaft journal bore, and apply engine oil to them.
2. Using a crankshaft bearing 1 replacing tool, press in a new bearing 1 (2) so that its seam (1) directs toward the exhaust manifold side. (See figure.)

Dimension (A)	Factory spec.	0 to 0.3 mm 0 to 0.0118 in.
---------------	---------------	--------------------------------

(1) Seam

(2) Crankshaft Bearing 1

(3) Cylinder Block

W10339460

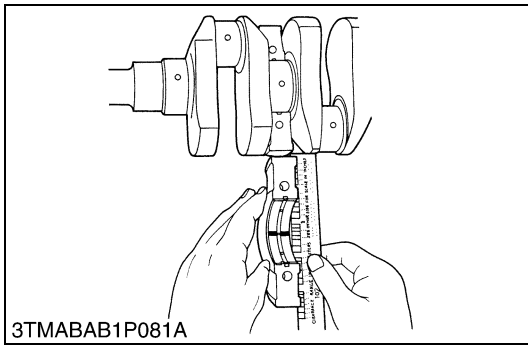

Oil Clearance between Crankshaft Journal and Crankshaft Bearing 2 and Crankshaft Bearing 3

1. Put a strip of plastigage (Code No. 07909-30241) on the center of the journal.
2. Install the bearing case and tighten the bearing case screws 1 to the specified torque, and remove the bearing case again.
3. Measure the amount of the flattening with the scale, and get the oil clearance.
4. If the oil clearance exceeds the allowable limit, replace the crankshaft bearing 2 (crankshaft bearing 3).
5. If the same size bearing is useless because of the crankshaft journal wear, replace it with an undersize one referring to the table and figure.

NOTE

- **Be sure not to move the crankshaft while the bearing case screws are tightened.**

[D722]

Oil clearance between crankshaft journal and crankshaft bearing 2 and crankshaft bearing 3	Factory spec.	0.028 to 0.059 mm 0.00110 to 0.00232 in.
	Allowable limit	0.20 mm 0.0079 in.
Crankshaft journal O.D. (Intermediate)	Factory spec.	39.934 to 39.950 mm 1.57221 to 1.57284 in.
Crankshaft bearing 3 I.D.	Factory spec.	39.978 to 39.993 mm 1.57394 to 1.57453 in.
Crankshaft journal O.D. (Flywheel side)	Factory spec.	43.978 to 43.993 mm 1.73142 to 1.73201 in.
Crankshaft bearing 2 I.D.	Factory spec.	43.984 to 44.026 mm 1.73165 to 1.73331 in.

[D905]

Oil clearance between crankshaft journal and crankshaft bearing 2	Factory spec.	0.034 to 0.095 mm 0.00134 to 0.00374 in.
	Allowable limit	0.20 mm 0.0079 in.
Crankshaft journal O.D. (Intermediate)	Factory spec.	47.934 to 47.950 mm 1.88716 to 1.88779 in.
Crankshaft bearing 2 I.D.	Factory spec.	47.984 to 48.029 mm 1.88913 to 1.89091 in.
Oil clearance between crankshaft journal and crankshaft bearing 3	Factory spec.	0.034 to 0.098 mm 0.00134 to 0.00386 in.
	Allowable limit	0.20 mm 0.0079 in.
Crankshaft journal O.D. (Flywheel side)	Factory spec.	51.921 to 51.940 mm 2.04413 to 2.04488 in.
Crankshaft bearing 3 I.D.	Factory spec.	51.974 to 52.019 mm 2.04622 to 2.04799 in.

W10340750

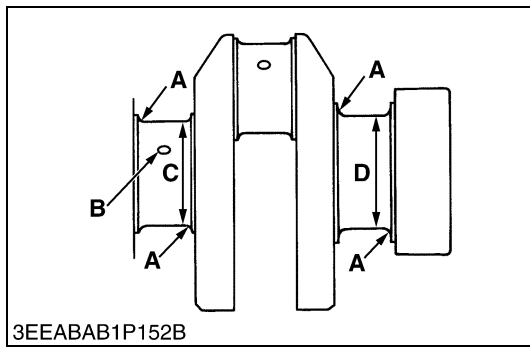

Oil Clearance between Crankshaft Journal and Crankshaft Bearing 2 and Crankshaft Bearing 3 (Continued)

(Reference)

- Undersize crankshaft bearing 2 and 3

[D722]

Undersize	Bearing	Code Number	Marking
0.2 mm 0.008 in.	Crankshaft bearing 2 02	15694-23930	020 US
	Crankshaft bearing 3 02	15861-23860	020 US
0.4 mm 0.016 in.	Crankshaft bearing 2 04	15694-23940	040 US
	Crankshaft bearing 3 04	15861-23870	040 US

[D905]

Undersize	Bearing	Code Number	Marking
0.2 mm 0.008 in.	Crankshaft bearing 2 02	16241-23930	020 US
	Crankshaft bearing 3 02	16241-23860	020 US
0.4 mm 0.016 in.	Crankshaft bearing 2 04	16241-23940	040 US
	Crankshaft bearing 3 04	16241-23870	040 US

- Undersize dimensions of crankshaft journal

[D722]

Undersize Dimension	0.2 mm 0.008 in.	0.4 mm 0.016 in.
	A	1.8 to 2.2 mm radius 0.071 to 0.087 in. radius
B	3 mm dia. 0.12 in. dia.	3 mm dia. 0.12 in. dia.
C	39.734 to 39.750 mm 1.56433 to 1.56496 in.	39.534 to 39.550 mm 1.55646 to 1.55709 in.
D	43.734 to 43.750 mm 1.72181 to 1.72244 in.	43.534 to 43.550 mm 1.71394 to 1.71457 in.
(0.8-S) The crankshaft journal must be fine-finished to higher than ∇∇∇∇		

[D905]

Undersize Dimension	0.2 mm 0.008 in.	0.4 mm 0.016 in.
	A	2.3 to 2.7 mm radius 0.0906 to 0.1063 in. radius
B	1.0 to 1.5 mm radius 0.0394 to 0.0591 in. radius	1.0 to 1.5 mm radius 0.0394 to 0.0591 in. radius
C	47.734 to 47.750 mm 1.87929 to 1.87992 in.	47.534 to 47.550 mm 1.87141 to 1.87204 in.
D	51.721 to 51.740 mm 2.03626 to 2.03700 in.	51.521 to 51.540 mm 2.02838 to 2.02913 in.
(0.8-S) The crankshaft journal must be fine-finished to higher than ∇∇∇∇		

W1042542

(E) Cylinder

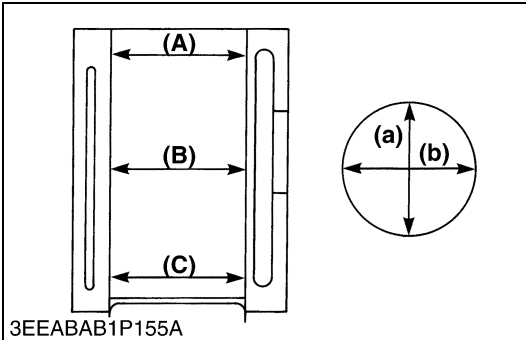
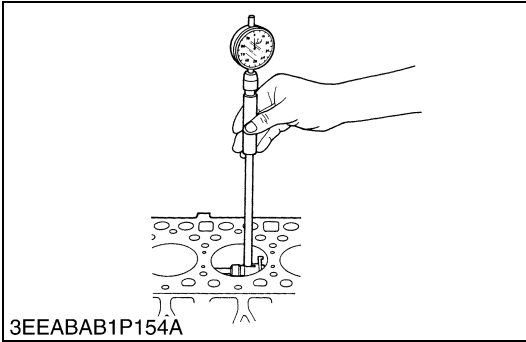

Cylinder Wear

1. Measure the I.D. of the cylinder at the six positions (see figure) with a cylinder gauge to find the maximum and minimum I.D.'s.
2. Get the difference (Maximum wear) between the maximum and the minimum I.D.'s.
3. If the wear exceeds the allowable limit, bore and hone to the oversize dimension. (Refer to “**Correcting Cylinder**”.)
4. Visually check the cylinder wall for scratches. If deep scratches are found, the cylinder should be bored. (Refer to “**Correcting Cylinder**”.)

[D722]

Cylinder liner I.D.	Factory spec.	67.000 to 67.019 mm 2.63779 to 2.63854 in.
	Allowable limit	67.169 mm 2.64444 in.

[D905]

Cylinder liner I.D.	Factory spec.	72.000 to 72.019 mm 2.83464 to 2.83539 in.
	Allowable limit	72.169 mm 2.84129 in.

- (A) Top
- (B) Middle
- (C) Bottom (Skirt)

- (a) Right-angled to Piston Pin
- (b) Piston Pin Direction

W10343890

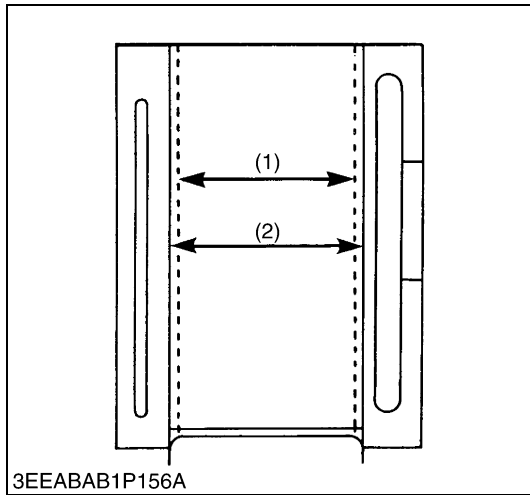

Correcting Cylinder

1. When the cylinder is worn beyond the allowable limit, bore and hone it to the specified dimension.

[D722]

Oversized cylinder liner I.D.	Factory spec.	67.250 to 67.269 mm 2.64764 to 2.64839 in.
	Allowable limit	67.419 mm 2.65429 in.
Finishing	Hone to 1.2 to 2.0 mm μR max. ▽▽▽ (0.000047 to 0.0079 in. μR max.)	

[D905]

Oversized cylinder liner I.D.	Factory spec.	72.500 to 72.519 mm 2.85433 to 2.85507 in.
	Allowable limit	72.669 mm 2.86098 in.
Finishing	Hone to 1.2 to 2.0 mm μR max. ▽▽▽ (0.000047 to 0.0079 in. μR max.)	

2. Replace the piston and piston rings with oversize ones.

[D722]

Oversize	Part Name	Code Number	Marking
0.25 mm 0.0098 in.	Piston	16851-21900	0.25 OS
	Piston ring assembly	16851-21090	0.25 OS

[D905]

Oversize	Part Name	Code Number	Marking
0.5 mm 0.0197 in.	Piston 05	16224-21910	05 OS
	Piston ring 05 assembly	15901-21090	05 OS

■ NOTE

- When the oversize cylinder is worn beyond the allowable limit, replace the cylinder block with a new one.

(1) Cylinder I.D. (Before Correction) (2) Oversized Cylinder I.D.

W10344480

[3] LUBRICATING SYSTEM

(1) Checking

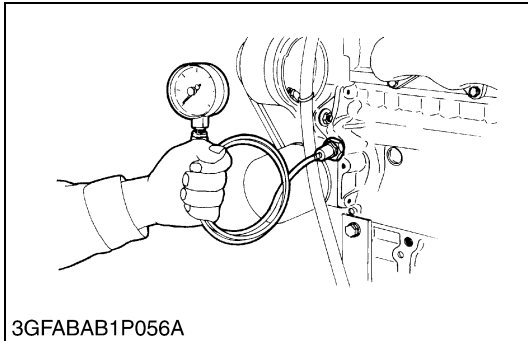

Engine Oil Pressure

1. Remove the engine oil pressure switch, and set a oil pressure tester (Code No.: 07916-32032).
2. Start the engine. After warming up, measure the oil pressure of both idling and rated speeds.
3. If the oil pressure is less than the allowable limit, check the following.
 - Engine oil insufficient.
 - Oil pump defective
 - Oil strainer clogged
 - Oil filter cartridge clogged
 - Oil gallery clogged
 - Excessive oil clearance
 - Foreign matter in the relief valve

Engine oil pressure	At idle speed	Factory spec.	More than 49 kPa 0.5 kgf/cm ² 7 psi
	At rated speed	Factory spec.	196 to 441 kPa 2.0 to 4.5 kgf/cm ² 36 to 64 psi
		Allowable limit	147 kPa 1.5 kgf/cm ² 27 psi

(When reassembling)

- After checking the engine oil pressure, tighten the engine oil pressure switch to the specified torque.

W10349520

(2) Servicing

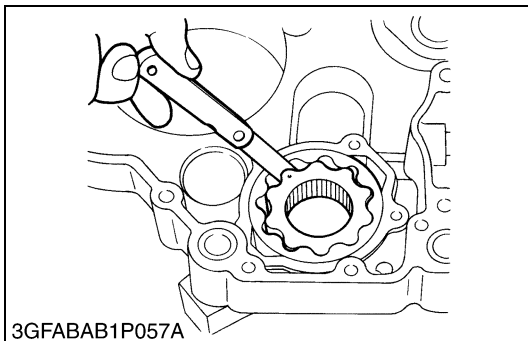

Rotor Lobe Clearance

1. Measure the clearance between lobes of the inner rotor and the outer rotor with a feeler gauge.
2. If the clearance exceeds the factory specifications, replace the oil pump rotor assembly.

Rotor lobe clearance	Factory spec.	D722	0.03 to 0.14 mm 0.0012 to 0.0055 in.
		D905	0.06 to 0.18 mm 0.0024 to 0.0071 in.

W10355630

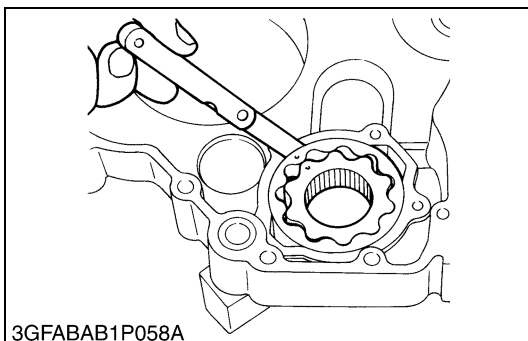

Clearance between Outer Rotor and Pump Body

1. Measure the clearance between the outer rotor and the pump body with a feeler gauge.
2. If the clearance exceeds the factory specifications, replace the oil pump rotor assembly.

Clearance between outer rotor and pump body	Factory spec.	D722	0.07 to 0.15 mm 0.0028 to 0.0059 in.
		D905	0.10 to 0.18 mm 0.0039 to 0.0071 in.

W10356560

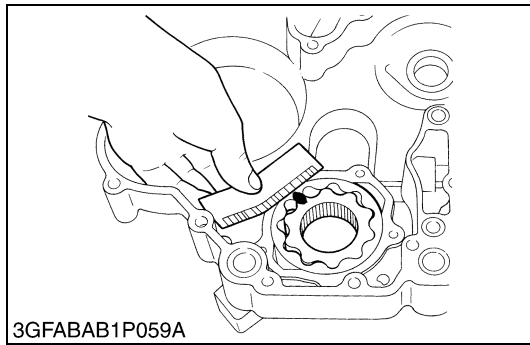

Clearance between Rotor and Cover

1. Put a strip of plastigage (Code No. 07909-30241) onto the rotor face with grease.
2. Install the cover and tighten the screws.
3. Remove the cover carefully, and measure the amount of the flattening with the scale and get the clearance.
4. If the clearance exceeds the factory specifications, replace the oil pump rotor assembly.

Clearance between rotor and cover	Factory spec.	D722	0.075 to 0.135 mm 0.00295 to 0.00531 in.
		D905	0.030 to 0.085 mm 0.0012 to 0.0033 in.

W10357320

[4] COOLING SYSTEM

(1) Checking and Adjusting

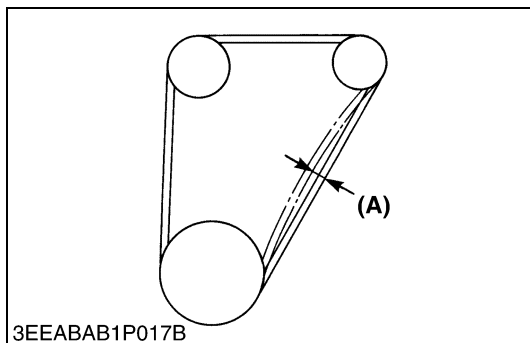

Fan Belt Tension

1. Measure the deflection (A), depressing the belt halfway between the fan drive pulley and alternator pulley at specified force (98 N, 10 kgf, 22 lbs).
2. If the measurement is not within the factory specifications, loosen the alternator mounting screws and relocate the alternator to adjust.

Deflection (A)	Factory spec.	7 to 9 mm 0.28 to 0.35 in.
----------------	---------------	-------------------------------

W10356670

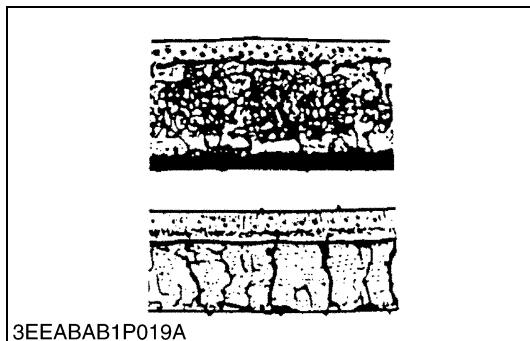

Fan Belt Damage and Wear

1. Check the fan belt for damage.
2. If the fan belt is damaged, replace it.
3. Check if the fan belt is worn and sunk in the pulley groove.
4. If the fan belt is nearly worn out and deeply sunk in the pulley groove, replace it.

(A) Good

(B) Bad

W10357580

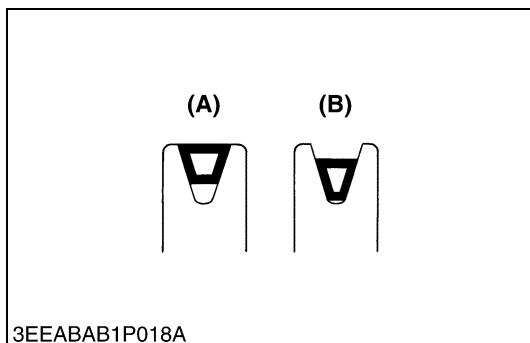

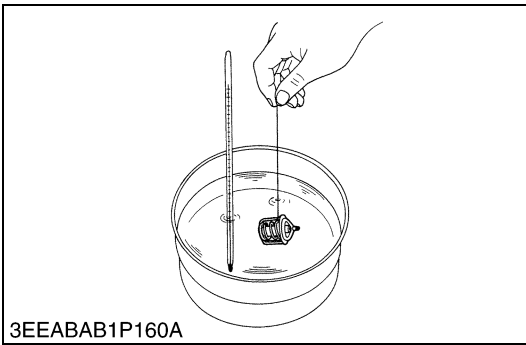

3EEABAB1P160A

Thermostat Valve Opening Temperature

1. Suspend the thermostat in the water by a string with its end inserted between the valve and seat.
2. Heating the water gradually, read the temperature when the valve opens and leaves the string.
3. Continue heating and read the temperature when the valve opens approx. 6 mm (0.236 in.).
4. If the measurement is not within the factory specifications, replace the thermostat.

Thermostat's valve opening temperature	Factory spec.	80.5 to 83.5 °C 176.9 to 182.3 °F
Temperature at which thermostat completely opens	Factory spec.	95 °C 203 °F

W10358490

CAUTION

- When removing the radiator cap, wait at least ten minutes after the engine has stopped and cooled down. Otherwise, hot water may gush out, scalding nearby people.

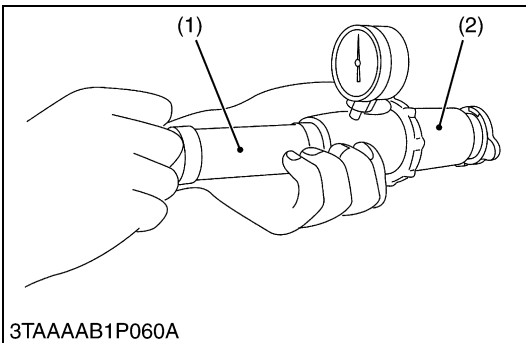

3TAAAAB1P060A

Radiator Cap Air Leakage

1. Set a radiator tester (1) and adaptor (2) (BANZAI Code No.: RCT-2A-30S) on the radiator cap.
2. Apply the specified pressure (88 kPa, 0.9 kgf/cm², 13 psi), and measure the time for the pressure to fall to 59 kPa (0.6 kgf/cm², 9 psi).
3. If the measurement is less than the factory specification, replace the radiator cap.

Pressure falling time	Factory spec.	More than 10 seconds for pressure fall from 88 to 59 kPa (from 0.9 to 0.6 kgf/cm ² , from 13 to 9 psi)
-----------------------	---------------	---

(1) Radiator Tester

(2) Adaptor

W10360900

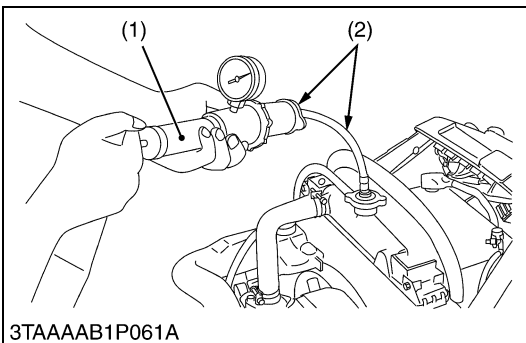

3TAAAAB1P061A

Radiator Water Leakage

1. Pour a specified amount of water into the radiator.
2. Set a radiator tester (1) (Code No. 07909-31551) and an adaptor (2) (BANZAI Code No.: RCT-2A-30S) and raise the water pressure to the specified pressure.
3. Check the radiator for water leaks.
4. For water leak from the pinhole, repair with the radiator cement. When water leak is excessive, replace the radiator.

Radiator water leakage test pressure	Factory spec.	137 kPa 1.4 kgf/cm ² 20 psi
--------------------------------------	---------------	--

(1) Radiator Tester

(2) Adaptor

W10361840

(2) Disassembling and Assembling

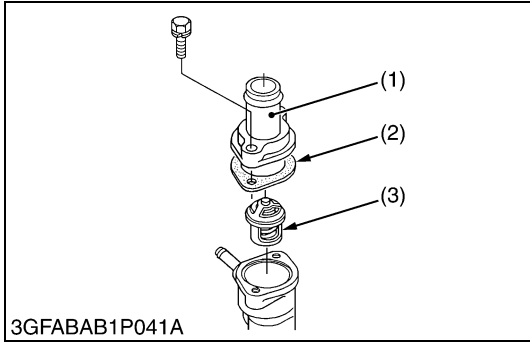

Thermostat Assembly

1. Remove the thermostat cover mounting screws, and remove the thermostat cover (1).
2. Remove the thermostat assembly (3).

(When reassembling)

- Apply a liquid gasket (Three Bond 1215 or equivalent) only at the thermostat cover side of the gasket (2).

- | | |
|-----------------------------|-------------------------|
| (1) Thermostat Cover | (3) Thermostat Assembly |
| (2) Thermostat Cover Gasket | |

W10363950

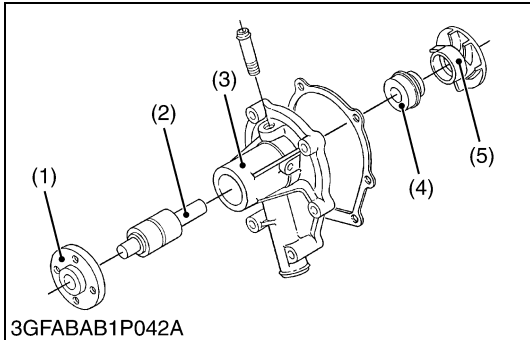

Water Pump Assembly

1. Loosen the alternator mounting bolts, and remove the fan belt.
2. Remove the fan and fan pulley.
3. Remove the water pump assembly from the gear case cover.
4. Remove the water pump flange (1).
5. Press out the water pump shaft (2) with the impeller (5) on it.
6. Remove the impeller from the water pump shaft.
7. Remove the mechanical seal (4).

(When reassembling)

- Apply a liquid gasket (Three Bond 1215 or equivalent) to the both sides of gasket.
- Replace the mechanical seal with new one.

- | | |
|-----------------------|---------------------|
| (1) Water Pump Flange | (4) Mechanical Seal |
| (2) Water Pump Shaft | (5) Impeller |
| (3) Water Pump Body | |

W10365080

[5] FUEL SYSTEM

(1) Checking and Adjusting

(A) Injection Pump

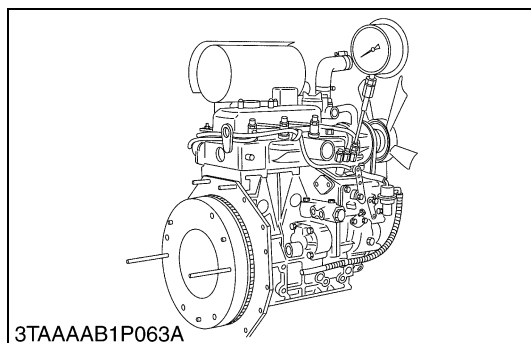
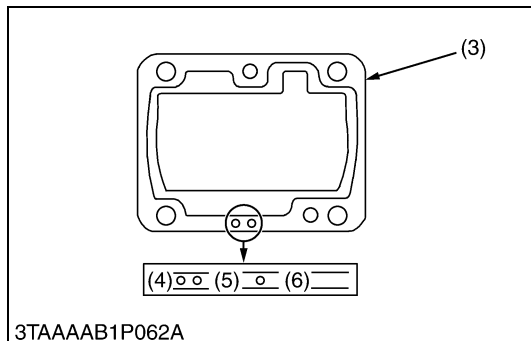
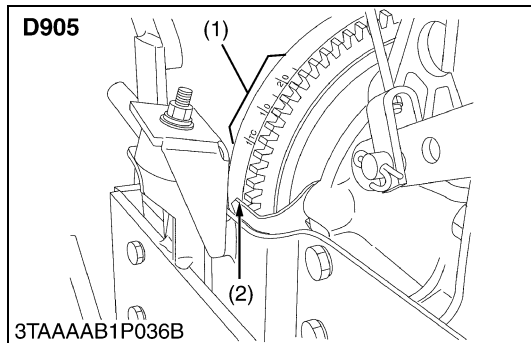
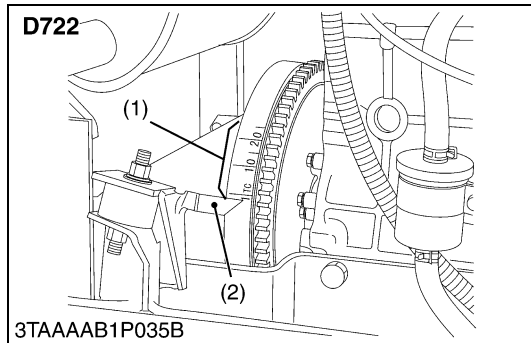

Injection Timing

1. Remove the injection pipes.
2. Remove the engine stop solenoid.
3. Turn the flywheel counterclockwise (facing the flywheel) until fuel flows from the delivery valve holder.
4. Continue to turn the flywheel slowly, and stop it as soon as the fuel level at the tip of the delivery valve holder begins to increase.
5. Check to see if the timing angle lines on the flywheel is aligned with the alignment mark (2).
6. If the injection timing is out of adjustment, readjust the timing with shims.

Injection timing	Factory spec.	D722	0.31 to 0.34 rad. (17.5 to 19.5 °) before T.D.C.
		D905	0.35 to 0.38 rad. (20 to 22 °) before T.D.C.

■ NOTE

- The sealant is applied to both sides of the shim (soft metal gasket shim). The liquid gasket is not required for assembling.
- Shims are available in thickness of 0.20 mm (0.0079 in.), 0.25 mm (0.0098 in.) and 0.30 mm (0.0118 in.). Combine these shims for adjustments.
- Addition or reduction of shim (0.05 mm, 0.0020 in.) delays or advances the injection timing by approx. 0.0087 rad. (0.5 °).
- In disassembling and replacing the injection pump, be sure to use the same number of new shims with the same thickness.
- Refer to figure below to check the thickness of the shims.

- | | |
|-----------------------------------|---|
| (1) Timing Line | (4) Two-holes : 0.20 mm (0.0079 in.) |
| (2) Alignment Mark | (5) One-hole : 0.25 mm (0.0098 in.) |
| (3) Shim (Soft Metal Gasket Shim) | (6) Without hole : 0.30 mm (0.0118 in.) |

W10369450

Fuel Tightness of Pump Element

1. Remove the engine stop solenoid.
2. Remove the injection pipes and glow plugs.
3. Install the injection pump pressure tester to the injection pump.
4. Set the speed control lever to the maximum speed position.
5. Turn the flywheel ten times or more to increase the pressure.
6. If the pressure can not reach the allowable limit, replace the pump element or injection pump assembly.

Fuel tightness of pump element	Allowable limit	14.7 MPa 150 kgf/cm ² 2133 psi
--------------------------------	-----------------	---

■ NOTE

- Apply liquid gasket (Three Bond 1215 or equivalent) to both sides of the solenoid cover gasket.

W10401760

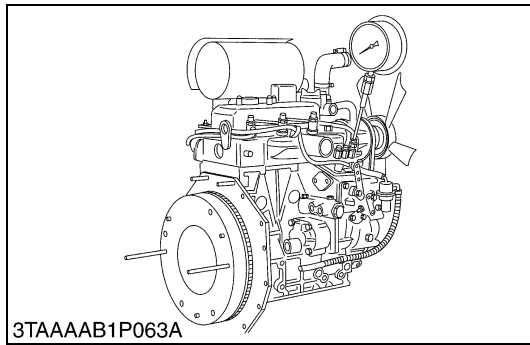

Fuel Tightness of Delivery Valve

1. Remove the engine stop solenoid.
2. Remove the injection pipes and glow plugs.
3. Set a pressure tester to the fuel injection pump.
4. Turn the flywheel and raise the pressure to approx. 14.7 MPa (150 kgf/cm², 2130 psi).
5. Now turn the flywheel back about half a turn (to keep the plunger free). Maintain the flywheel at this position and clock the time taken for the pressure to drop from 14.7 to 13.7 MPa (from 150 to 140 kgf/cm², from 2130 to 1990 psi).
6. Measure the time needed to decrease the pressure from 14.7 to 13.7 MPa (from 150 to 140 kgf/cm², from 2130 to 1990 psi).
7. If the measurement is less than allowable limit, replace the delivery valve.

■ **NOTE**

- **Apply liquid gasket (Three Bond 1215 or equivalent) to both sides of the solenoid cover gasket.**

Fuel tightness of delivery valve	Factory spec.	10 seconds 14.7 → 13.7 MPa 150 → 140 kgf/cm ² 2130 → 1990 psi
	Allowable limit	5 seconds 14.7 → 13.7 MPa 150 → 140 kgf/cm ² 2130 → 1990 psi

W10403300

(B) Injection Nozzle



CAUTION

- Check the injection pressure and condition after confirming that there is nobody standing in the direction the fume goes.
If the fume from the nozzle directly contacts the human body, cells may be destroyed and blood poisoning may be caused.

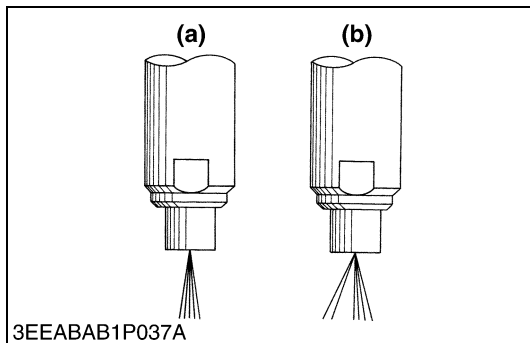

Nozzle Spraying Condition

1. Set the injection nozzle to a nozzle tester (Code No. 07909-31361), and check the nozzle spraying condition.
2. If the spraying condition is defective, replace the nozzle piece.

(a) Good

(b) Bad

W10411400

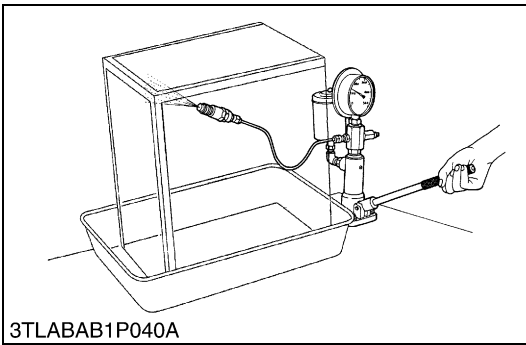

3TLABAB1P040A

Fuel Injection Pressure

1. Set the injection nozzle to a nozzle tester (Code No. 07909-31361).
2. Slowly move the tester handle to measure the pressure at which fuel begins jetting out from the nozzle.
3. If the measurement is not within the factory specifications, replace the adjusting washer (1) in the nozzle holder to adjust it.

Fuel injection pressure	Factory spec.	13.73 to 14.71 MPa 140 to 150 kgf/cm ² 1990 to 2130 psi
-------------------------	---------------	--

(Reference)

- Pressure variation with 0.01 mm (0.0004 in.) difference of adjusting washer thickness.
Approx. 235 kPa (2.4 kgf/cm², 34 psi)

(1) Adjusting Washer

W10408820

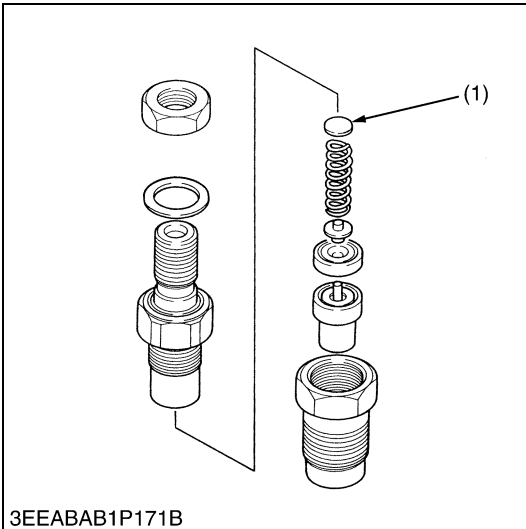

3EEABAB1P171B

Valve Seat Tightness

1. Set the injection nozzle to a nozzle tester (Code No. 07909-31361).
2. Raise the fuel pressure, and keep at 12.75 MPa (130 kgf/cm², 1849 psi) for 10 seconds.
3. If any fuel leak is found, replace the nozzle piece.

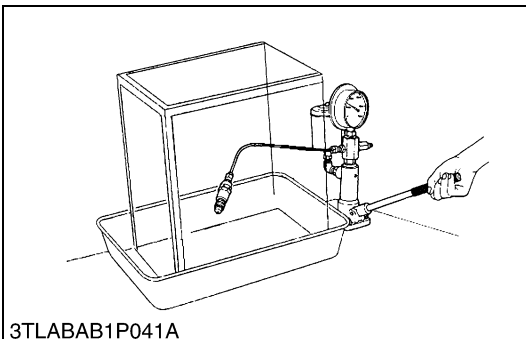

3TLABAB1P041A

Valve seat tightness	Factory spec.	No fuel leak at 12.75 MPa 130 kgf/cm ² 1849 psi
----------------------	---------------	---

W10412730

(2) Disassembling and Assembling

(A) Injection Nozzle

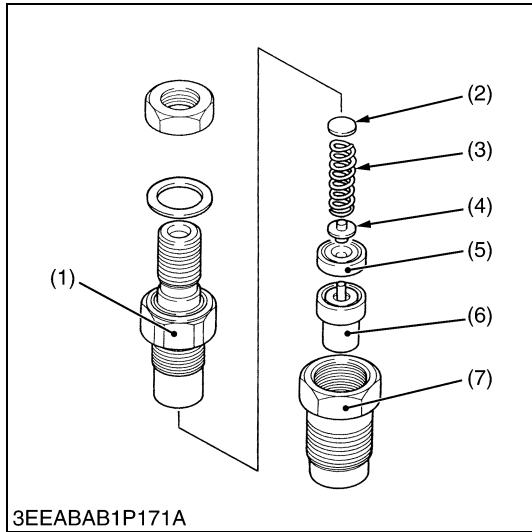

Nozzle Holder

1. Secure the nozzle retaining nut (7) with a vise.
2. Remove the nozzle holder (1), and take out parts inside.

(When reassembling)

- Assemble the nozzle in clean fuel oil.
- Install the push rod (4), noting its direction.
- After assembling the nozzle, be sure to adjust the fuel injection pressure.

Tightening torque	Nozzle holder	34.3 to 39.2 N·m 3.5 to 4.0 kgf·m 25.3 to 28.9 ft-lbs
	Overflow pipe nut	19.6 to 24.5 N·m 2.0 to 2.5 kgf·m 14.5 to 18.1 ft-lbs
	Nozzle holder assembly	49.0 to 68.6 N·m 5.0 to 7.0 kgf·m 36.2 to 50.6 ft-lbs

- | | |
|----------------------|--------------------------|
| (1) Nozzle Holder | (5) Distance Piece |
| (2) Adjusting Washer | (6) Nozzle Piece |
| (3) Nozzle Spring | (7) Nozzle Retaining Nut |
| (4) Push Rod | |

W10415210

2 TRANSAXLE

MECHANISM

CONTENTS

1. STRUCTURE	2-M1
2. TRAVELLING SYSTEM	2-M2
[1] HYDROSTATIC TRANSMISSION	2-M2
(1) Structure	2-M2
(2) Pump and Motor	2-M3
(3) Charge Relief Valve	2-M3
(4) Check and High Pressure Relief Valve	2-M4
(5) Oil Flow	2-M5
(6) Control Linkage	2-M9
[2] RANGE GEAR SHIFT SECTION	2-M10
[3] FRONT WHEEL DRIVE SECTION	2-M10
[4] DIFFERENTIAL GEAR SECTION	2-M11
(1) Differential Gears	2-M11
(2) Differential Lock	2-M12
[5] BRAKE SECTION	2-M13
3. PTO SYSTEM	2-M14
[1] PTO CLUTCH AND VALVE	2-M14
[2] MID AND REAR PTO SECTION	2-M16
4. OTHERS	2-M17
[1] HYDRAULIC PUMP DRIVE GEAR SECTION	2-M17

1. STRUCTURE

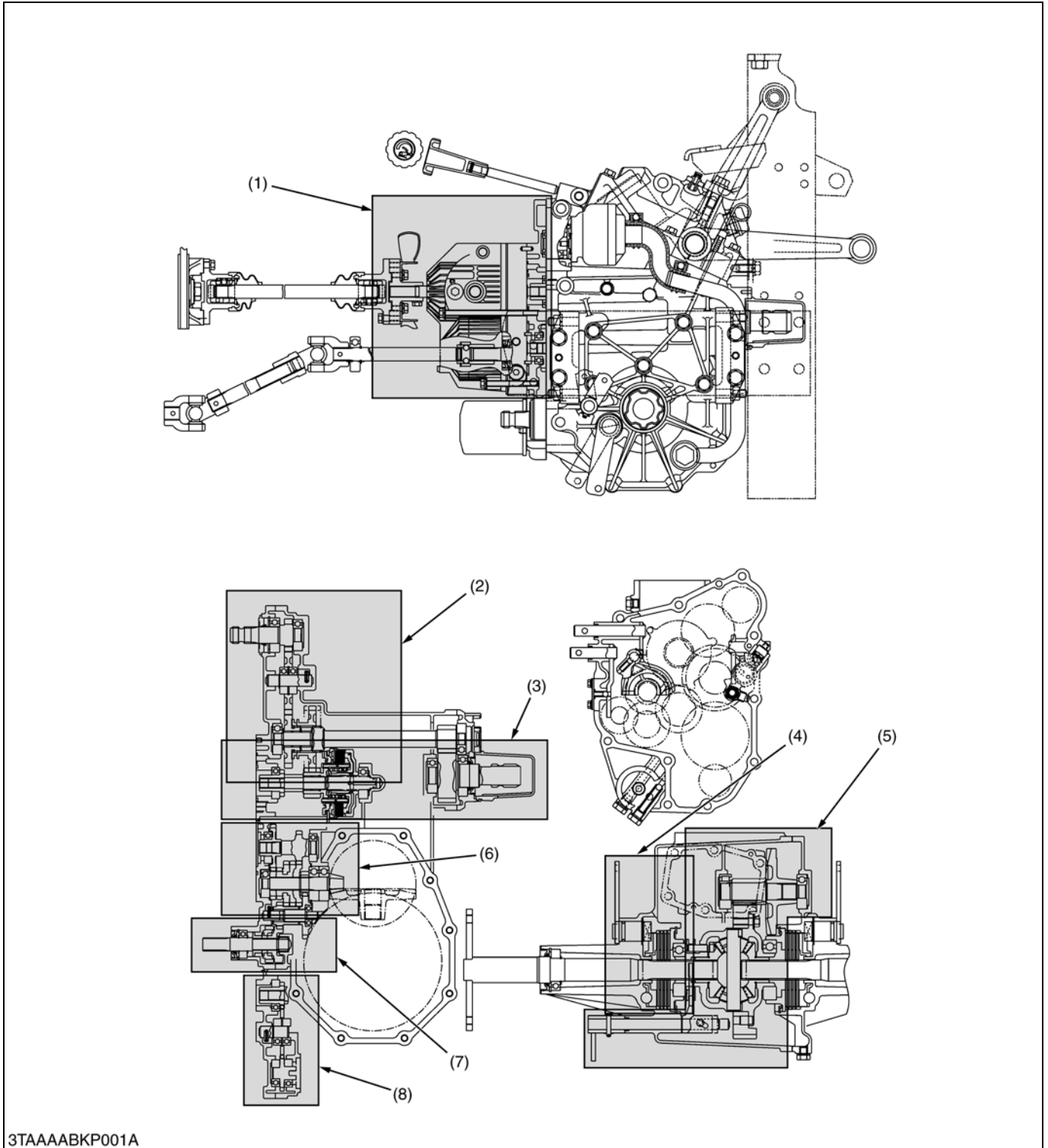

3TAAAABKP001A

- | | | | |
|------------------------------|-------------------------------|------------------------------------|---------------------------------------|
| (1) Hydrostatic Transmission | (4) Brake Section | (7) Front Wheel Drive Gear Section | (8) Hydraulic Pump Drive Gear Section |
| (2) Mid-PTO Section | (5) Differential Gear Section | | |
| (3) Rear PTO Section | (6) Range Gear Shift Section | | |

2. TRAVELLING SYSTEM

[1] HYDROSTATIC TRANSMISSION

(1) Structure

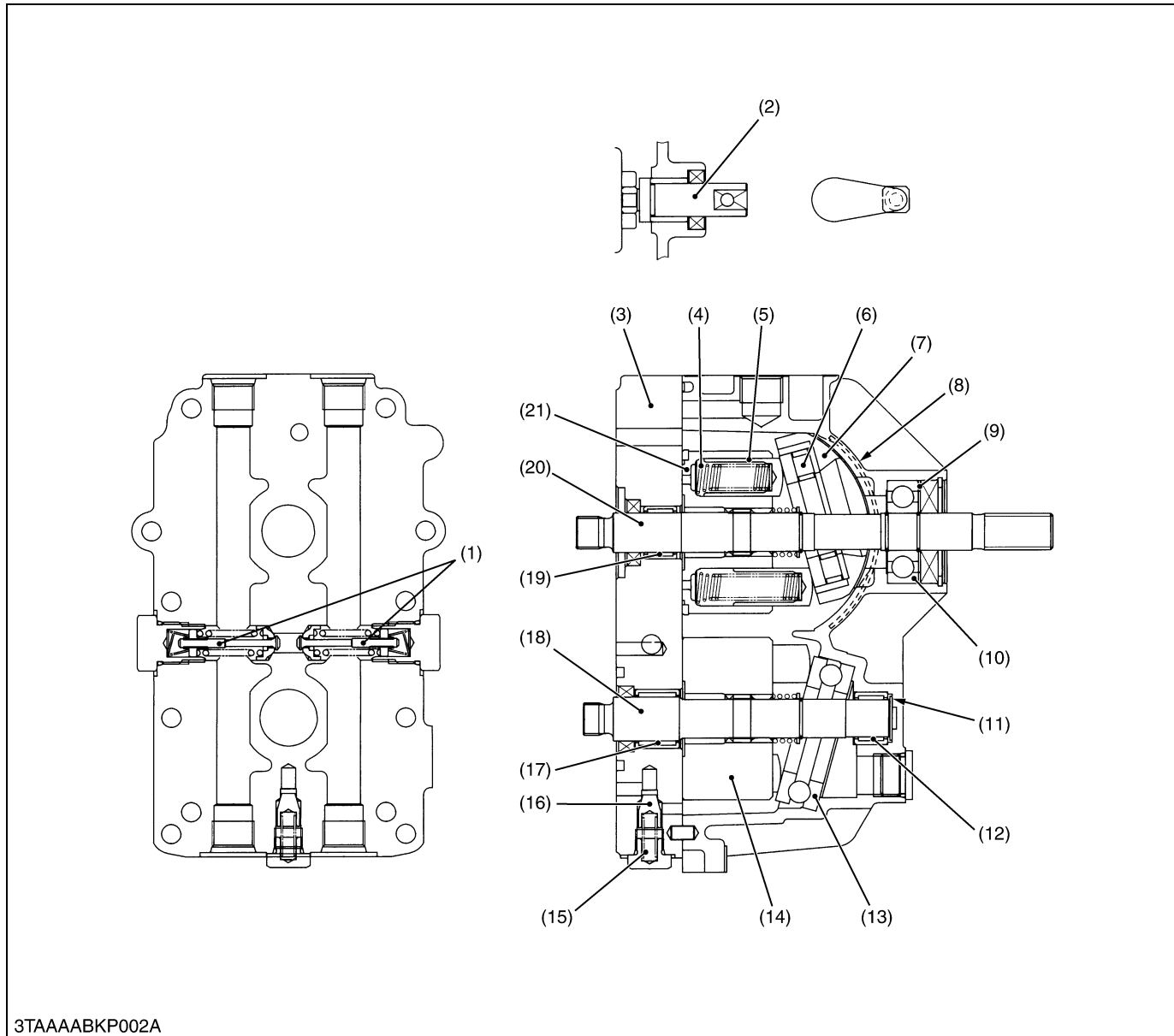

3TAAAABKP002A

- | | | | |
|--|---------------------------|-----------------------------|----------------------------|
| (1) Check and High Pressure Relief Valve | (6) Thrust Roller Bearing | (12) Needle Bearing | (17) Needle Bearing |
| (2) Trunnion Arm | (7) Swashplate | (13) Thrust Ball Bearing | (18) Motor Shaft |
| (3) Center Section | (8) Cradle Bearing | (14) Cylinder Block (Motor) | (19) Needle Bearing |
| (4) Piston Spring | (9) Spacer | (15) Charge Relief Spring | (20) Pump Shaft |
| (5) Piston | (10) Ball Bearing | (16) Charge Relief Valve | (21) Cylinder Block (Pump) |
| | (11) Thrust Washer | | |

The hydrostatic transmission consists of variable displacement piston pump, fixed displacement piston motor and valve system.

(2) Pump and Motor

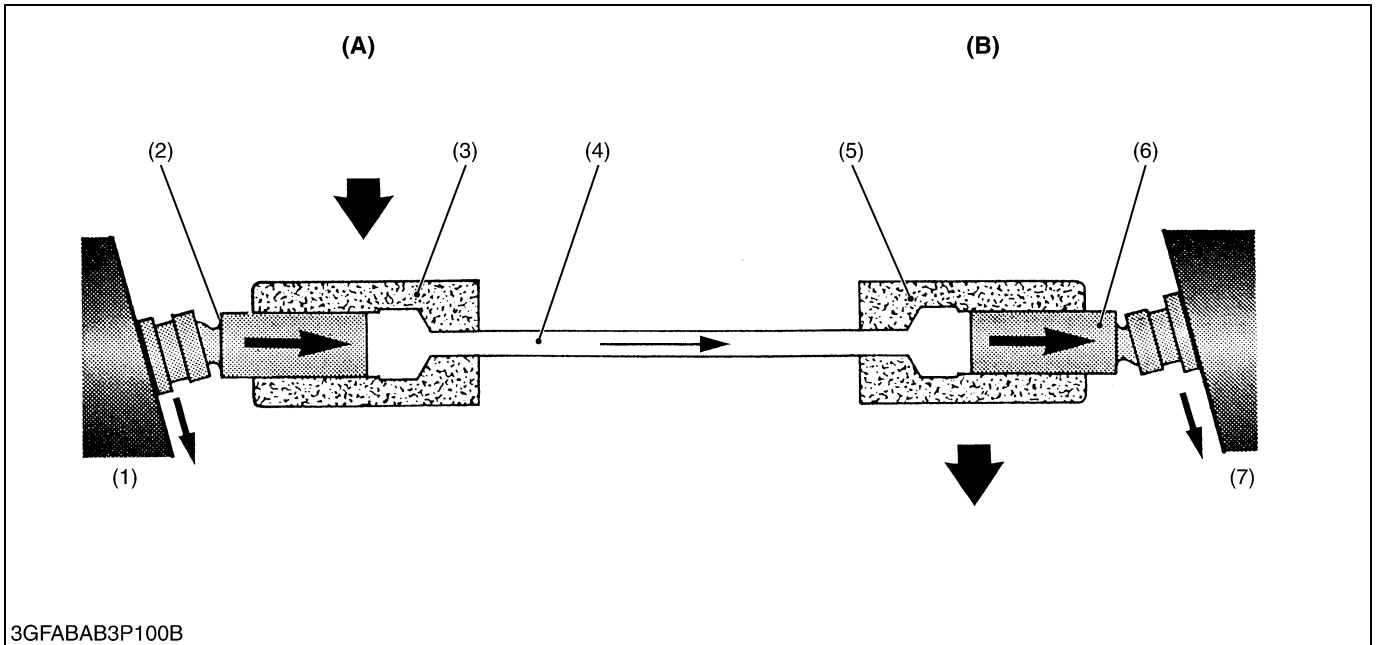

3GFABAB3P100B

- | | | | |
|----------------|--------------|----------------|------------------|
| (1) Swashplate | (4) Oil | (6) Piston | (A) Pump |
| (2) Piston | (5) Cylinder | (7) Swashplate | (B) Motor |
| (3) Cylinder | | | |

Pump and motor cylinder, each containing pistons, are connected by lines. Cylinders and lines are filled with oil. Pistons ride against swashplates (1) and (7) located in pump **(A)** and motor **(B)**.

In the pump **(A)**, as the cylinder (3) rotates, pistons (2) move across the sloping face of swashplate (1) and slide in or out of their cylinder bores. The oil (4), forced out by the pump pistons (2), causes the motor pistons (6) to slide out of their cylinder bores.

In the motor **(B)**, sliding out of the cylinder (5) and moving across the sloping face of swashplate (7), the pistons (6) rotate the cylinder (5).

(3) Charge Relief Valve

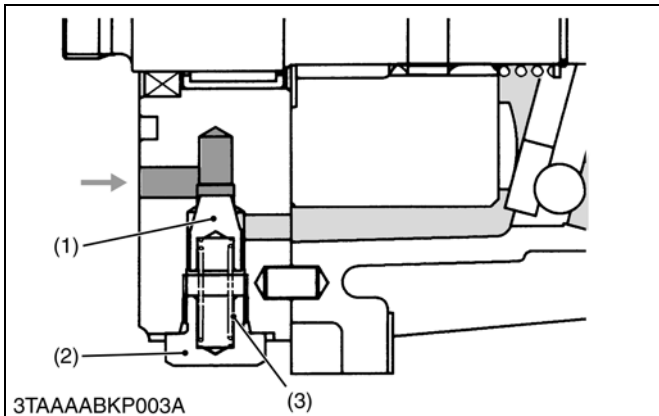

3TAAABKP003A

While pumped and filtered oil flows into the main oil circuit through the check and high pressure relief valves, and excessive oil passes to the housing through the charge relief valve.

Oil temperature	Valve operating pressure
50 °C (122 °F)	294 to 490 kPa 3.0 to 5.0 kgf/cm ² 42.7 to 71.1 psi

- | | |
|------------------------|------------|
| (1) Charge Relief Cone | (3) Spring |
| (2) Plug | |

W1013064

(4) Check and High Pressure Relief Valve

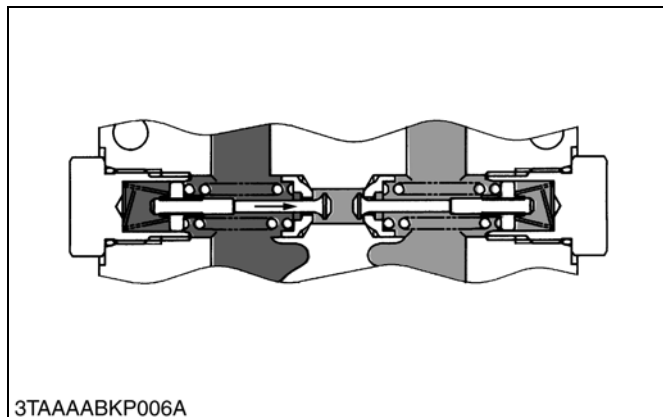
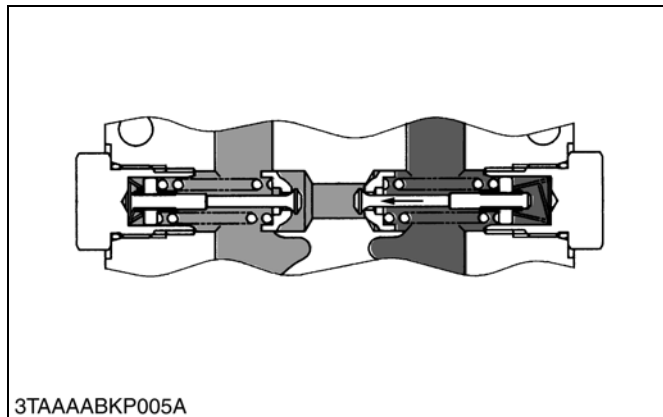
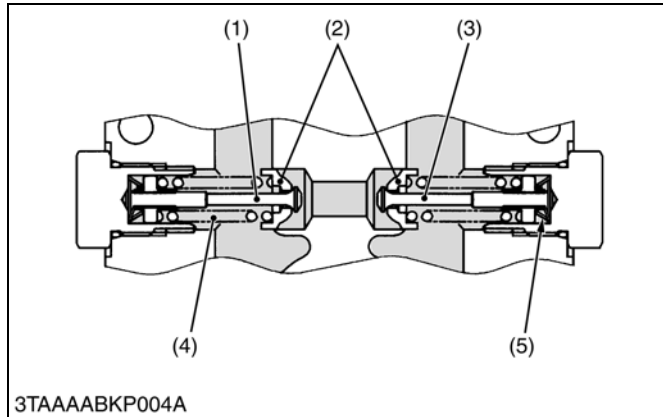

The check and high pressure relief valves monitor the oil pressure in each line of the main oil circuit.

In neutral, both check valves are open and charging oil enters into the main oil circuit through the valves.

At normal operation, the check valve in the high pressure side is closed and it pushes and opens the another one.

When excessively high pressure is built up in one line, the high pressure relief valve located in this line is open and the oil flows into another line.

Oil temperature	Relief valve operating pressure
50 °C (122 °F)	13.7 MPa
	140 kgf/cm ²
	1991 psi

- (1) Relief Valve
- (2) Check Valve
- (3) Relief Valve
- (4) Relief Spring
- (5) Check Spring

W1013207

(5) Oil Flow

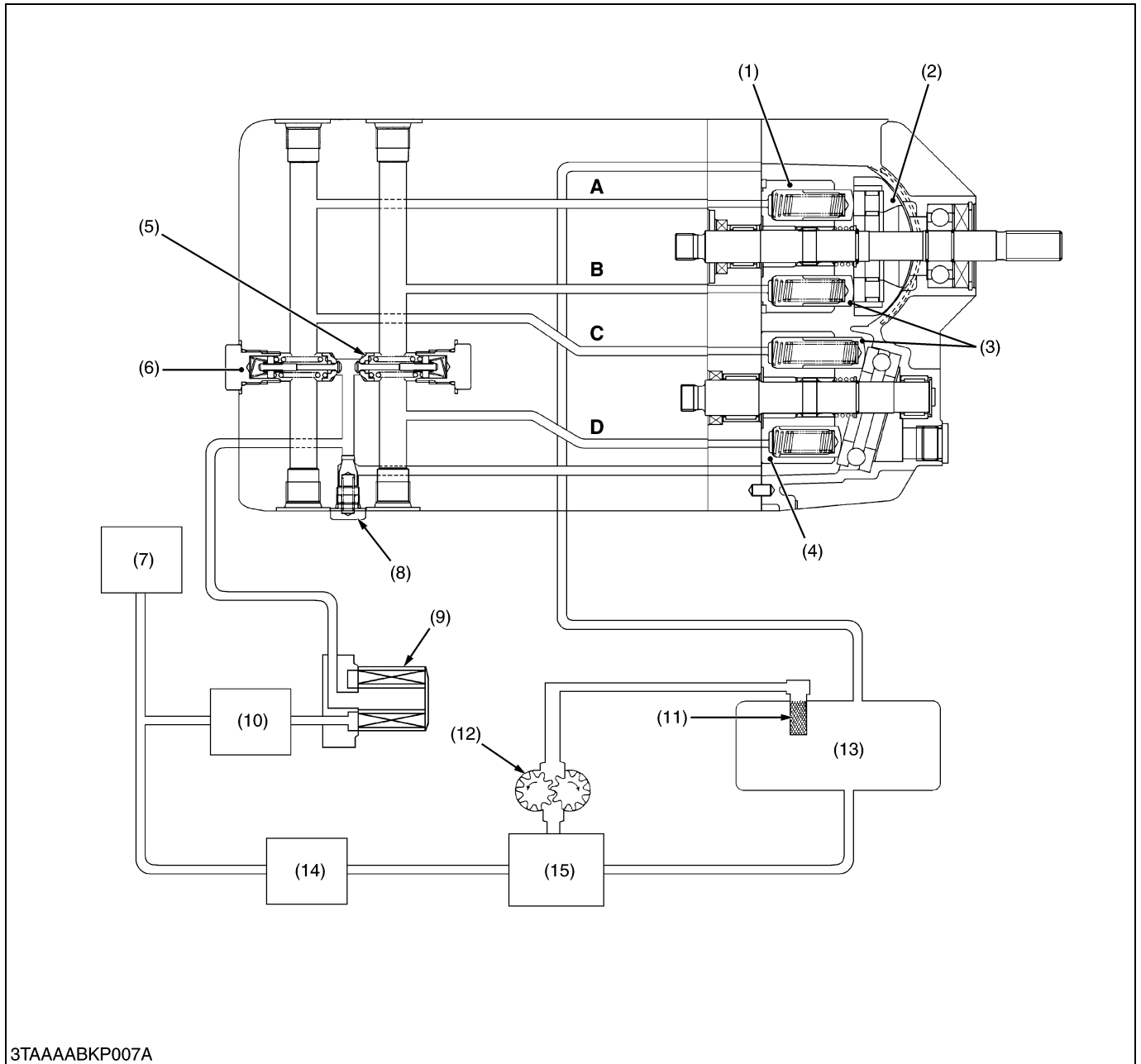

- | | | | |
|--|--|--|-------------------|
| (1) Cylinder Block (Pump) | (6) Check and High Pressure Relief Valve (Forward) | (11) Oil Strainer | A : A Port |
| (2) Swashplate | (7) PTO Clutch Valve | (12) Hydraulic Pump | B : B Port |
| (3) Piston | (8) Charge Relief Valve | (13) Transmission Case | C : C Port |
| (4) Cylinder Block (Motor) | (9) Oil Filter Cartridge | (14) Power Steering | D : D Port |
| (5) Check and High Pressure Relief Valve (Reverse) | (10) PTO Relief Valve | (15) Flow Priority Valve (Hydraulic Control Valve) | |

The pump and motor are joined in a closed hydraulic loop and most of oil circulates within the main oil circuit. A little oil lubricates and oozes out from the clearance between the moving parts of the case. Then oil in the main oil circuit of the HST needs to be supplied a want.

The oil from the power steering circuit flows into the HST for charging.

The charge oil aids smooth operation of pistons for pump and motor. The charge oil passes through the oil filter cartridge to charge relief valve port. The rest of oil passes through the charge relief valve into the HST housing. And overflow oil from HST housing return to the transmission case.

■ Neutral

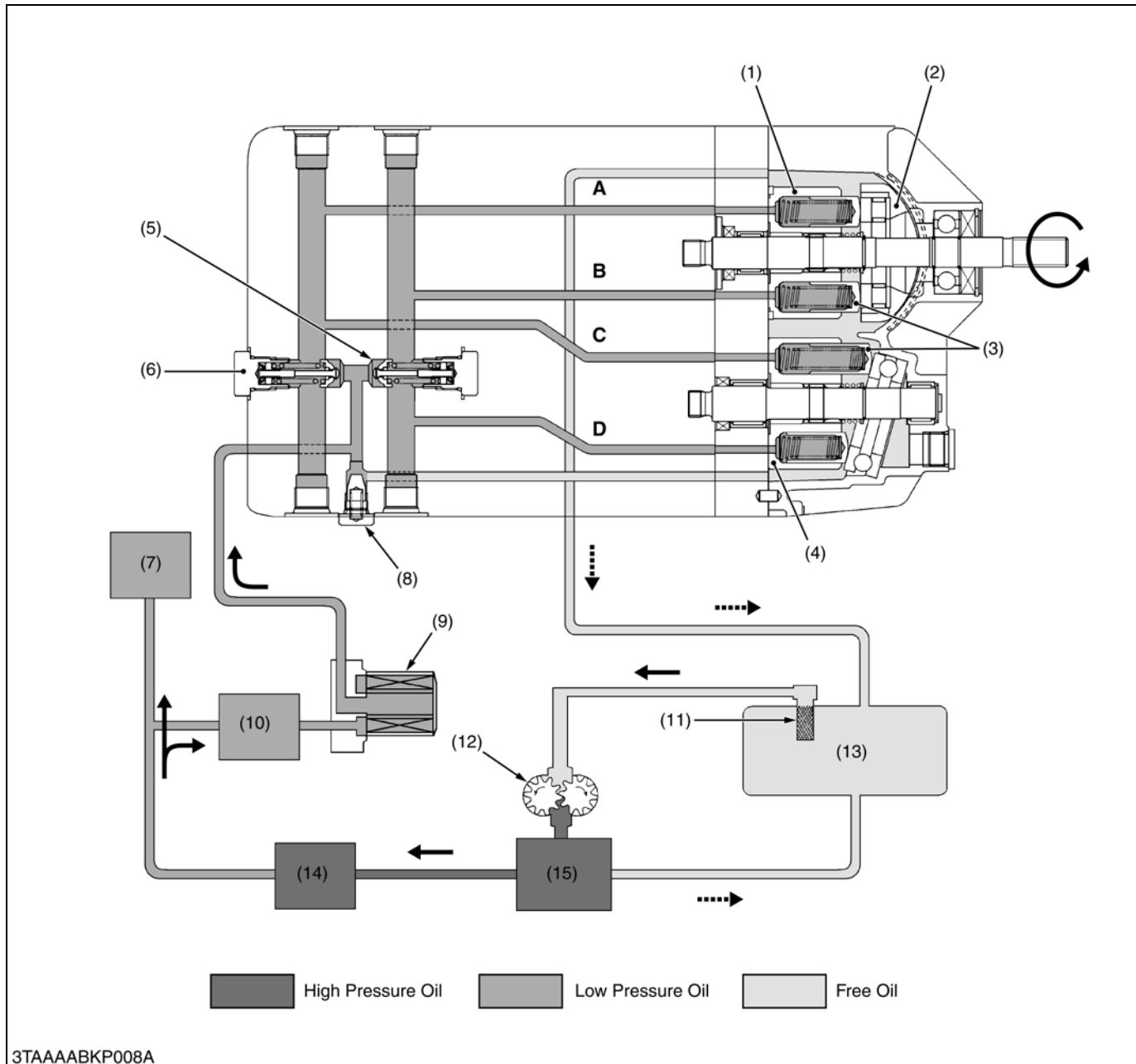

- | | | | |
|--|--|--|-------------------|
| (1) Cylinder Block (Pump) | (6) Check and High Pressure Relief Valve (Forward) | (11) Oil Strainer | A : A Port |
| (2) Swashplate | (7) PTO Clutch Valve | (12) Hydraulic Pump | B : B Port |
| (3) Piston | (8) Charge Relief Valve | (13) Transmission Case | C : C Port |
| (4) Cylinder Block (Motor) | (9) Oil Filter Cartridge | (14) Power Steering | D : D Port |
| (5) Check and High Pressure Relief Valve (Reverse) | (10) PTO Relief Valve | (15) Flow Priority Valve (Hydraulic Control Valve) | |

When the speed control pedal is in neutral, the variable swashplate is at right angles to the pump pistons and they only rotate with cylinder block without reciprocating. Since the oil is not being pumped to the motor, the cylinder block in the motor is stationary and the output shaft does not move.

■ Forward

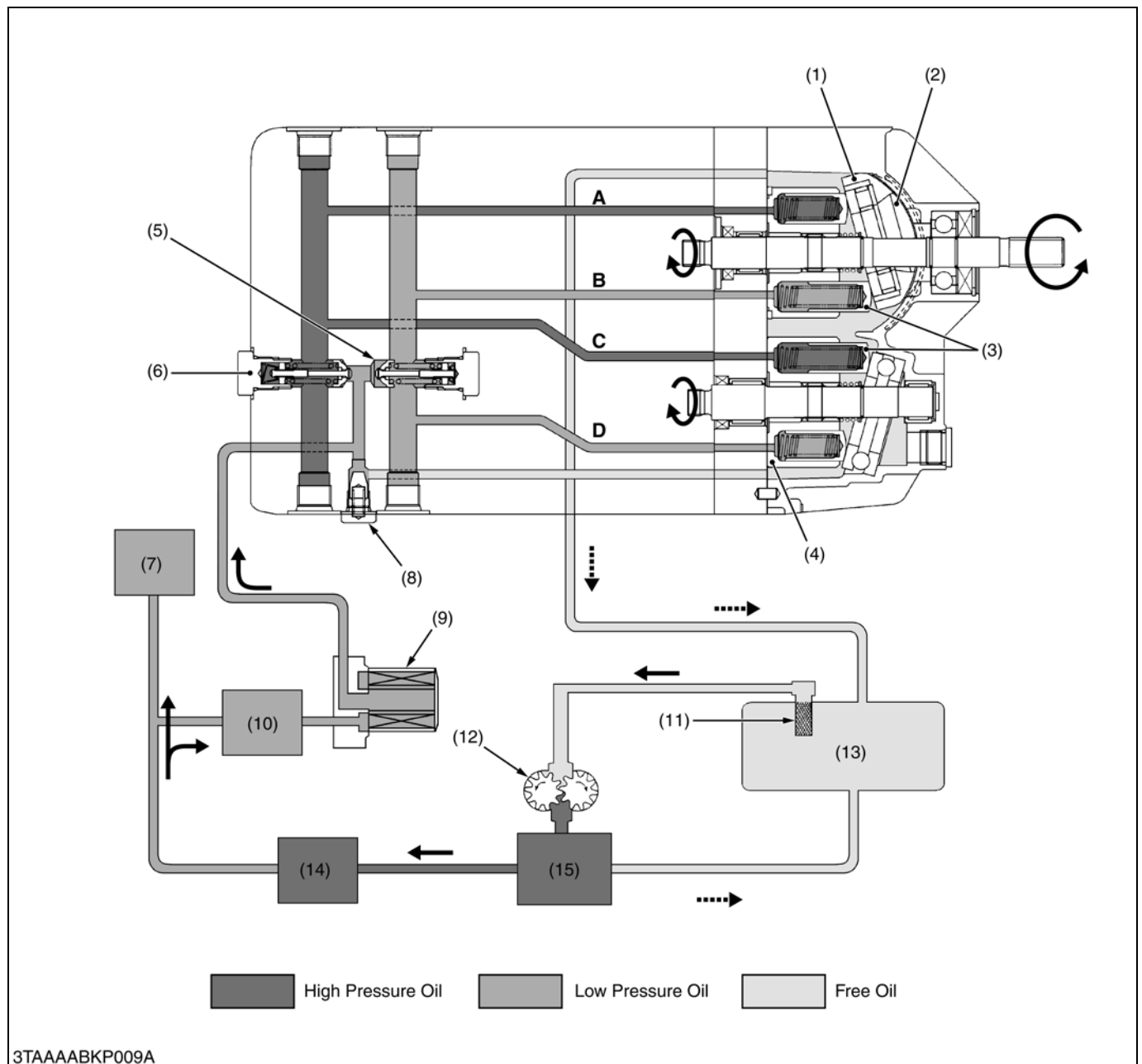

- | | | | |
|--|--|--|-------------------|
| (1) Cylinder Block (Pump) | (6) Check and High Pressure Relief Valve (Forward) | (11) Oil Strainer | A : A Port |
| (2) Swashplate | (7) PTO Clutch Valve | (12) Hydraulic Pump | B : B Port |
| (3) Piston | (8) Charge Relief Valve | (13) Transmission Case | C : C Port |
| (4) Cylinder Block (Motor) | (9) Oil Filter Cartridge | (14) Power Steering | D : D Port |
| (5) Check and High Pressure Relief Valve (Reverse) | (10) PTO Relief Valve | (15) Flow Priority Valve (Hydraulic Control Valve) | |

When the speed control pedal is stepped on and in forward, the variable swashplate is tilted as shown in figure above.

As the pump cylinder block rotates with the input shaft, oil is forced out of pump port **A** at high pressure. As pressure oil enters motor port **C**, the pistons, which align with port **C**, are pushed against the swashplate and slide down the inclined surface.

Then the output shaft rotates with the motor cylinder block. This drives the machine forward and the angle of pump swashplate determines the output shaft speed.

As the motor cylinder block continues to rotate, oil is forced out of motor port **D** at low pressure and returns to the pump.

■ Reverse

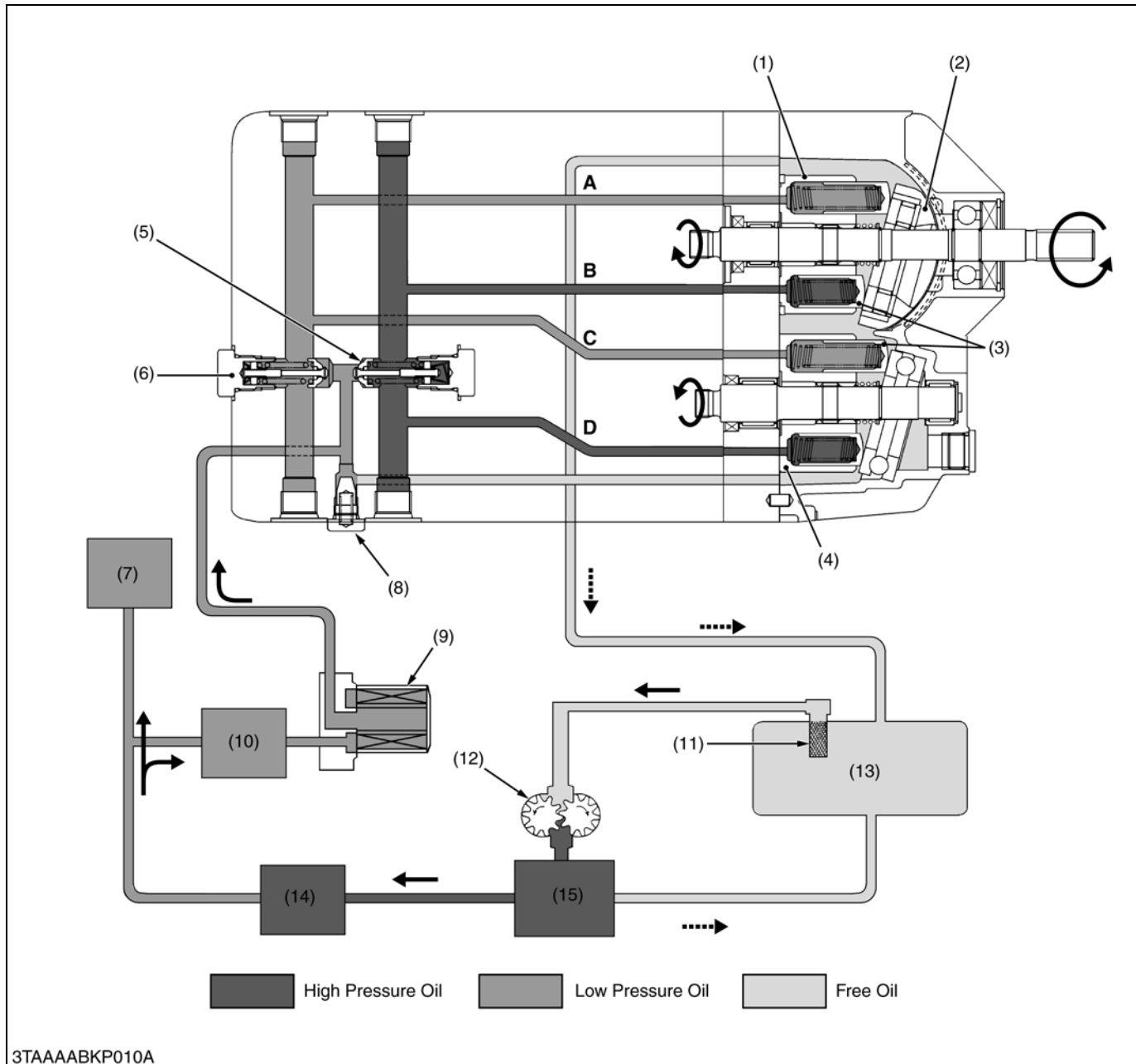

3TAAABKP010A

- | | | | |
|--|--|--|-------------------|
| (1) Cylinder Block (Pump) | (6) Check and High Pressure Relief Valve (Forward) | (11) Oil Strainer | A : A Port |
| (2) Swashplate | (7) PTO Clutch Valve | (12) Hydraulic Pump | B : B Port |
| (3) Piston | (8) Charge Relief Valve | (13) Transmission Case | C : C Port |
| (4) Cylinder Block (Motor) | (9) Oil Filter Cartridge | (14) Power Steering | D : D Port |
| (5) Check and High Pressure Relief Valve (Reverse) | (10) PTO Relief Valve | (15) Flow Priority Valve (Hydraulic Control Valve) | |

When the speed control pedal is stepped on and in reverse, the variable swashplate is tilted as shown in figure above.

As the pump cylinder block rotates with the input shaft, oil is forced out of pump port **B** at high pressure. As pressure oil enters motor port **D**, the pistons, which align with port **D**, are pushed against the swashplate and slide down the inclined surface.

Then the output shaft rotates with the motor cylinder block. This drives the machine rearward and the angle of pump swashplate determines the output shaft speed.

As the motor cylinder block continues to rotate, oil is forced out of motor port **C** at low pressure and returns to the pump.

(6) Control Linkage

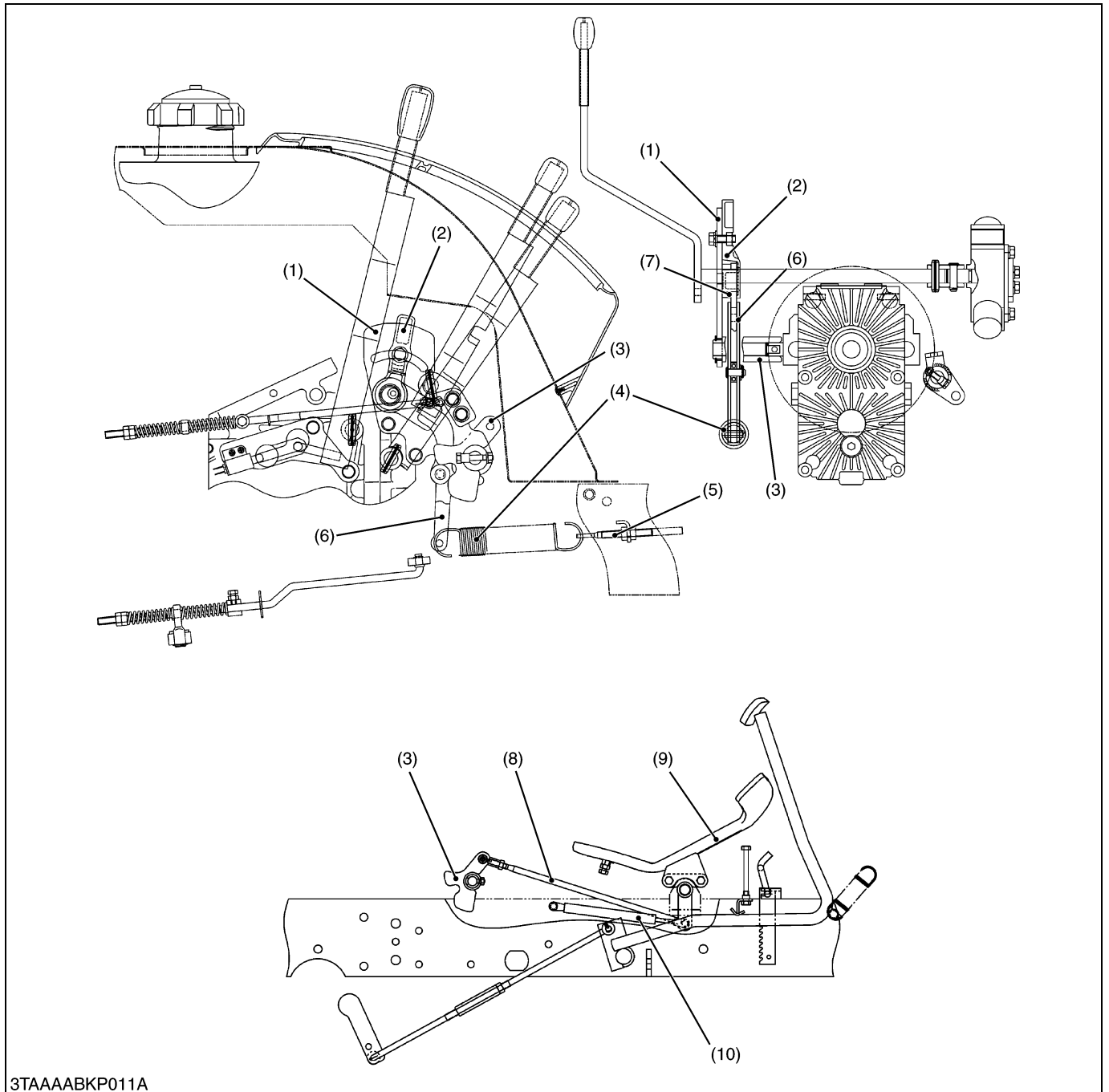

3TAAAABKP011A

- | | | | |
|--------------------------|--------------------|-----------------------|-------------------------|
| (1) Neutral Plate | (4) Neutral Spring | (7) Collar | (9) Speed Control Pedal |
| (2) Neutral Adjust Lever | (5) Adjust Rod | (8) Speed Control Rod | (10) Damper |
| (3) Trunnion Arm | (6) Neutral Arm | | |

The speed control pedal (9) and the trunnion shaft of variable swashplate are linked with the speed control rod (8) and the trunnion arm (3). As the front of the pedal is depressed, the swashplate rotates and forward travelling speed increases. Depressing the rear end increases reverse speed.

The trunnion arm (3) is returned to neutral position by the neutral arm (6) and the tension of neutral spring (4). At the same time, the swashplate is returned to neutral, when the pedal is released. The damper (10) connected to the speed control pedal restricts the movement of the linkage to prevent abrupt operation or reversing.

[2] RANGE GEAR SHIFT SECTION

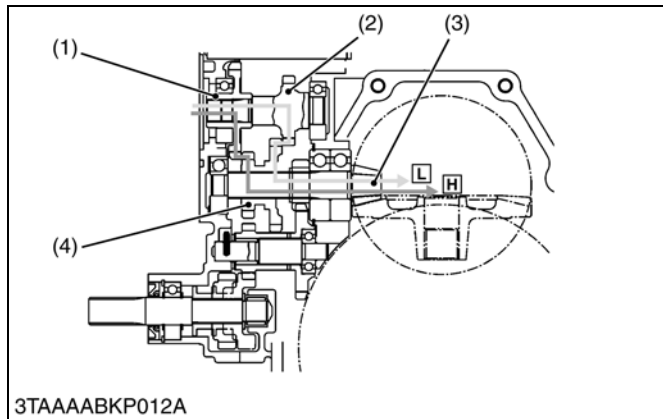

Two kinds of power flow are selected by operating the range gear shift lever to shift the 16T-24T shifter gear (4) on the spiral bevel gear shaft (3).

■ Low Range

17T Gear Shaft (2) → Shifter Gear (24T) (4) → Spiral Bevel Pinion Shaft (3).

■ High Range

25T Gear (1) → Shifter Gear (16T) (4) → Spiral Bevel Pinion Shaft (3).

- | | |
|--------------------|-------------------------------|
| (1) 25T Gear | (3) Spiral Bevel Pinion Shaft |
| (2) 17T Gear Shaft | (4) 16T-24T Shifter Gear |

W1014705

[3] FRONT WHEEL DRIVE SECTION

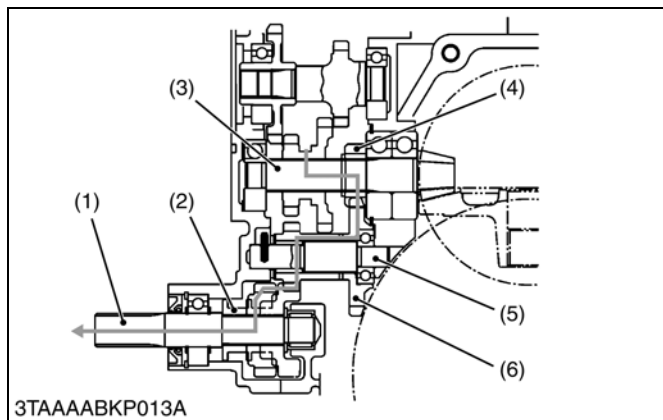

2-wheel drive or 4-wheel drive is selected by changing the position of 19T shifter gear (2) with the front wheel drive lever.

When the front wheel drive lever is set to “**Disengaged**” position, the 19T shifter gear (2) is neutral and power is not transmitted to the front wheel drive shaft (1).

When the front wheel drive lever is set to “**Engaged**” position, the 19T shifter gear (2) slides to the right to engage with 13T-25T gear (6) on the front wheel drive idle shaft (5). Therefore, the power from spiral bevel pinion shaft (3) is transmitted to the front wheel drive shaft (1) through the gears.

- | | |
|-------------------------------|----------------------------------|
| (1) Front Wheel Drive Shaft | (4) 12T Gear |
| (2) 19T Shifter Gear | (5) Front Wheel Drive Idle Shaft |
| (3) Spiral Bevel Pinion Shaft | (6) 13T-25T Gear |

W1014843

[4] DIFFERENTIAL GEAR SECTION

(1) Differential Gears

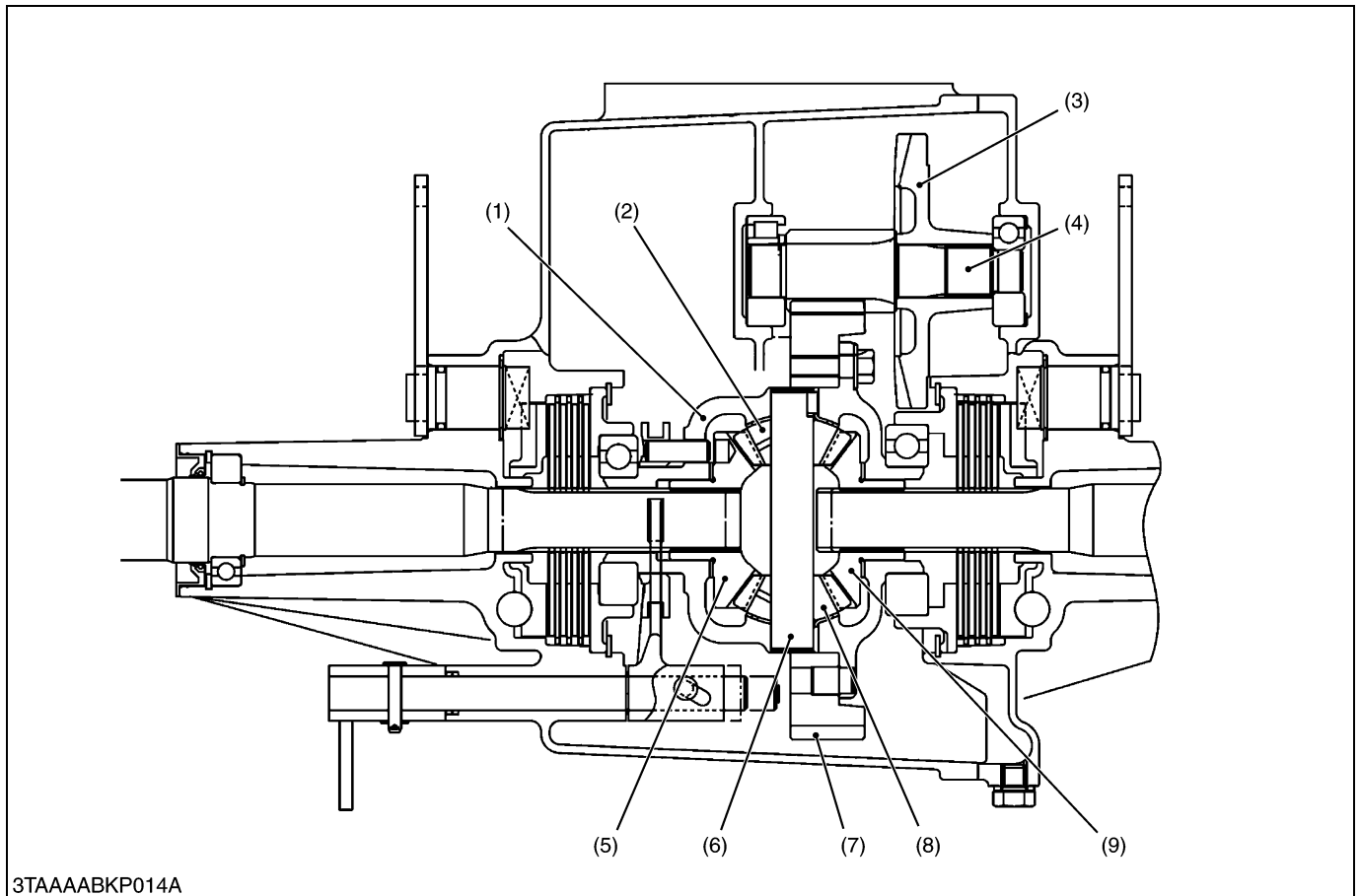

- | | | | |
|---------------------------|----------------------------|-------------------------------|----------------------------|
| (1) Differential Case | (4) 10T Final Gear Shaft | (6) Differential Pinion Shaft | (8) Differential Pinion |
| (2) Differential Pinion | (5) Differential Side Gear | (7) 66T Final Gear | (9) Differential Side Gear |
| (3) 37T Spiral Bevel Gear | | | |

1. During Straight Running

Rotation of the spiral bevel pinion is transmitted to the 37T spiral bevel gear (3), 10T final gear shaft (4), 66T final gear (7) and differential case (1).

When road resistance to the right and left wheels are equal, differential pinions (2), (8) and differential side gears (5), (9) are all rotate as a unit. Both rear axles received equal input, and both wheels turn at the same speed, allowing the tractor to go straight ahead.

At this time, differential pinions (2), (8) do not rotate around the differential pinion shaft (6).

2. During Turning

When the tractor turns, the road resistance to the inside tire increases. In other words, if one of tires slows down, revolution difference is generated in the differential side gears (5), (9). When rotation of one differential side gear becomes lower than the other, differential pinions (2), (8) begin rotating around differential pinion shaft (6). The other differential side gear is increased in speed by the speed increment of differential pinion shaft (6). This means that rotation of one rear axle is slowed down and that of the other rear axle is increased. Thus, the tractor turn smoothly without power loss.

The combined number of revolutions of the right and left differential side gears is always twice that of the spiral bevel gear (3). When spiral bevel gear revolution is 100 min^{-1} (rpm), and if one of the differential side gears stops moving, the revolution of the other differential side gear becomes 200 min^{-1} (rpm) and if one rotates at 50 min^{-1} (rpm), the other rotates at 150 min^{-1} (rpm).

(2) Differential Lock

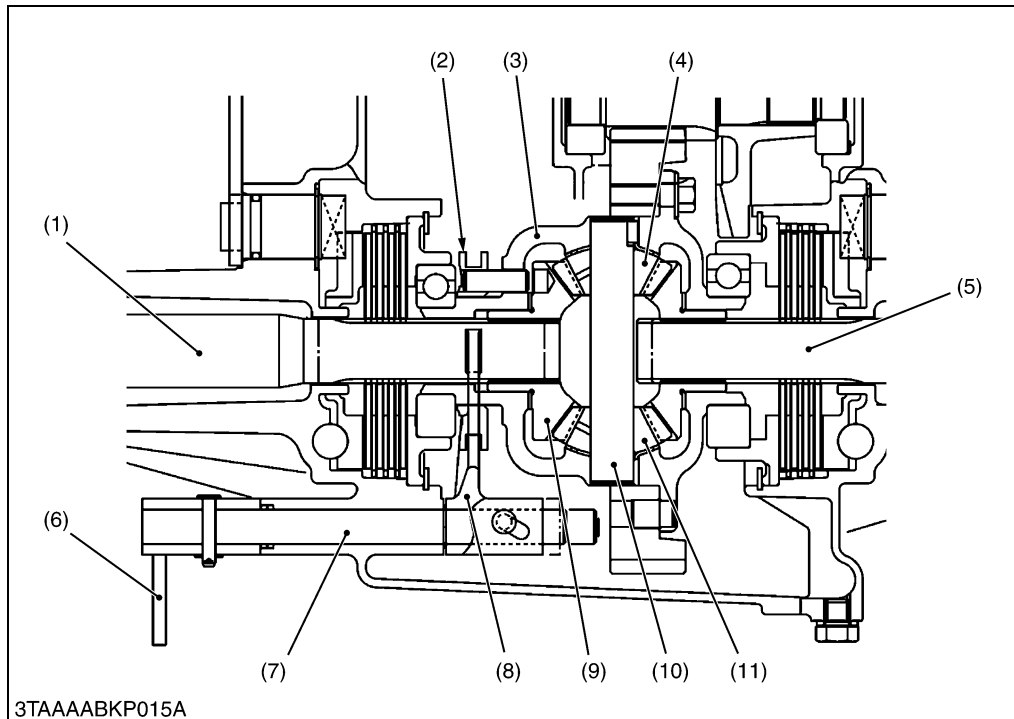

- (1) Rear Axle
- (2) Differential Lock Shifter
- (3) Differential Case
- (4) Differential Pinion
- (5) Rear Axle
- (6) Differential Lock Arm
- (7) Differential Lock Shaft
- (8) Differential Lock Shift Fork
- (9) Differential Side Gear
- (10) Differential Pinion Shaft
- (11) Differential Pinion

W1015160

3TAAABKP015A

When resistance to the right and left tires are greatly different due to ground conditions or type of work, the tire with less resistance slips and prevents the tractor from moving ahead. To compensate for this drawback, the differential lock restricts the differential action and causes both rear axles to rotate as a unit.

When the differential lock pedal is stepped on, it causes the differential lock arm (6) and differential lock shaft (7) to rotate, which will move the differential lock shift fork (8) and the differential lock shifter (2) toward the differential side gear (9). The pins on the differential lock shifter (2) go into the holes in the differential case (3) to cause the differential case (3), differential lock shifter (2) and differential side gear (9) to rotate as a unit.

Therefore, differential pinions (4), (11) are unable to rotate around differential pinion shaft (10) and identical revolutions are transmitted to the right and left rear axle (1), (5).

[5] BRAKE SECTION

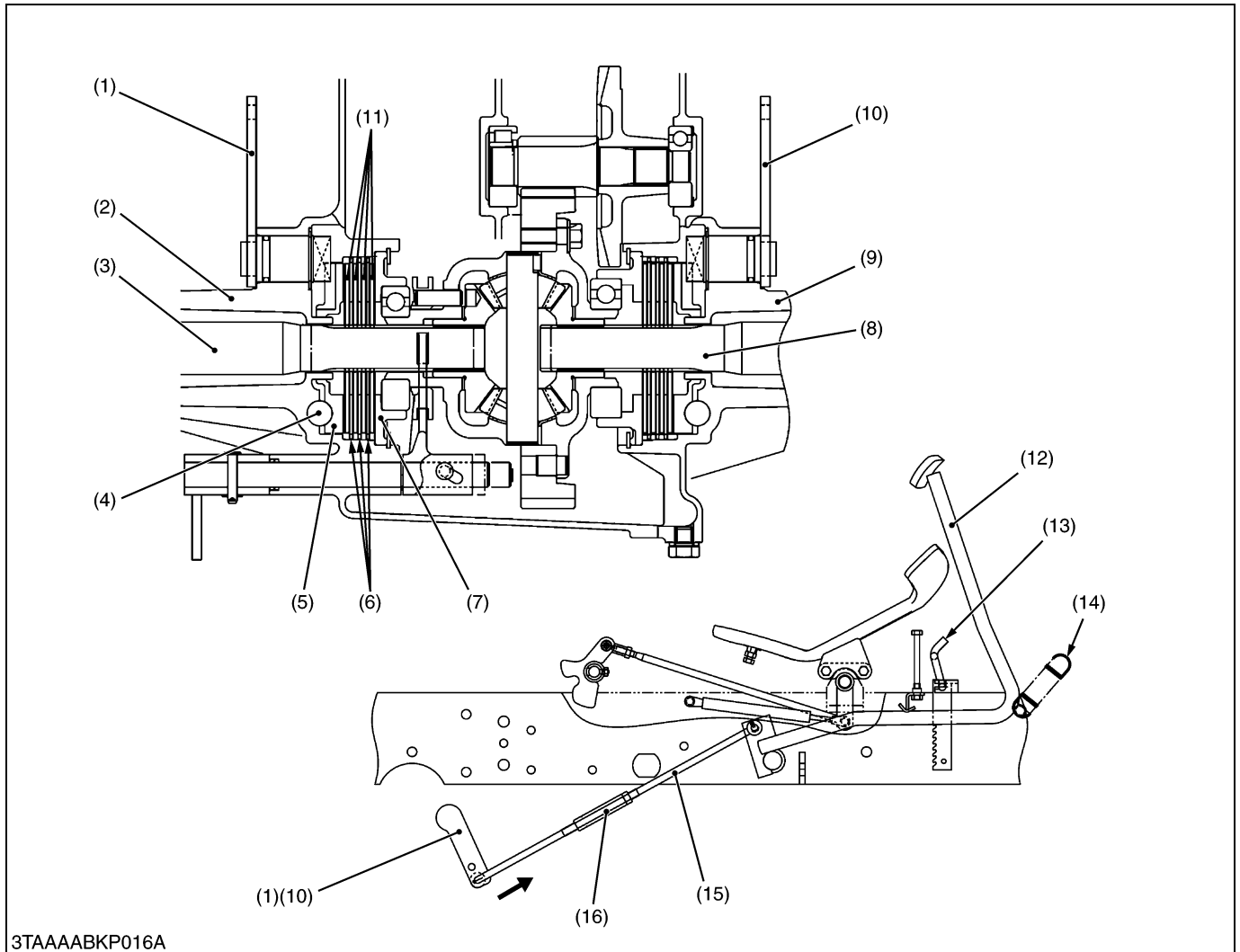

- | | | | |
|------------------------|-----------------------|-------------------------|-------------------------------|
| (1) Brake Cam Lever LH | (5) Cam Plate LH | (9) Axle Cover | (13) Parking Brake Lock Pedal |
| (2) Transmission Case | (6) Friction Plate | (10) Brake Cam Lever RH | (14) Spring |
| (3) Rear Axle LH | (7) Bearing Holder LH | (11) Brake Disc | (15) Brake Rod |
| (4) Steel Ball | (8) Rear Axle RH | (12) Brake Pedal | (16) Turnbuckle |

The mechanical wet disc brakes are used for right and left travelling brakes. They are operated by the brake pedal (12) through the mechanical linkages and provide stable braking and require little adjustment.

The brake body is incorporated in the transmission case (2) and axle cover (9) filled with transmission oil.

For greater braking force, four brake discs (11) are provided at the right and left sides respectively, and the friction plates (6) fixed to the transmission case (2) and axle cover (9) are arranged between the brake discs (11).

■ Travelling Brake

When the brake pedal (12) is depressed, the linkage causes the brake cam levers (1), (10) to turn into the direction of arrow shown in the above figure.

Therefore, the cam plates also moves and rides on the steel balls set in the grooves of the transmission case (2) and axle cover (9) to press the brake disc, the rear axle (3), (8) are braked by the frictional force generated by the cam plate and brake disc.

■ Parking Brake

When the parking brake is applied, the brake pedal (12) locked by the parking brake lock pedal (13) to actuate the brake mechanism same as a travelling brake.

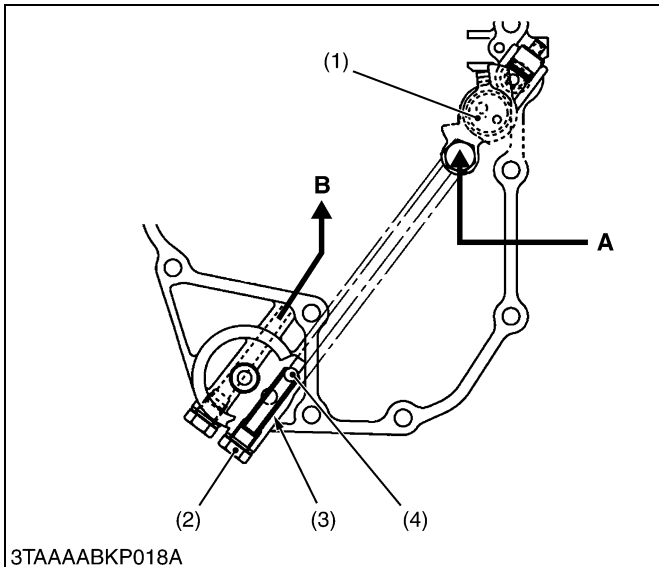

PTO Relief Valve

The PTO relief valve is provided to control the PTO operating pressure. When the oil pressure exceed the relief valve setting pressure, relief valve opens and the oil flows into PTO clutch and hydrostatic transmission.

(Reference)

- Relief valve setting pressure : 471 kPa
4.8 kgf/cm²
68.3 psi

- (1) PTO Clutch Valve
- (2) Plug
- (3) Spring
- (4) Steel Ball

- A : From Power Steering Controller**
- B : To Hydrostatic Transmission**

W1015382

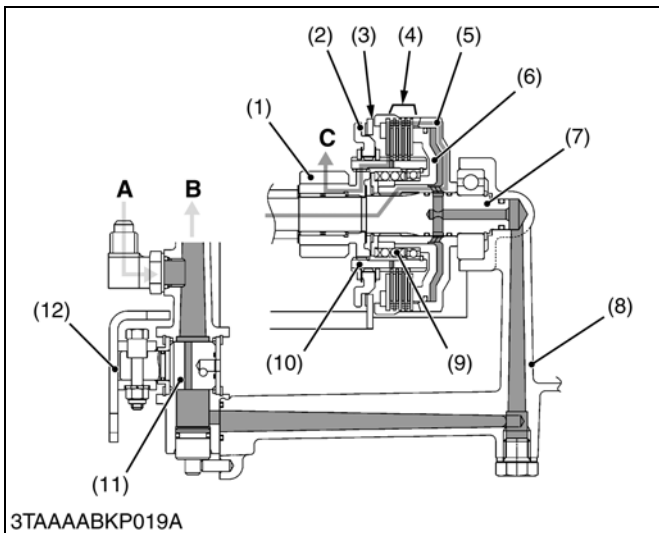

PTO Clutch "Engaged"

The oil from power steering controller flows into the PTO clutch valve (11).

When the PTO clutch lever is set at the "Engaged" position, the PTO clutch valve (11) rotates and from the oil line to the PTO clutch pack.

Oil entering the clutch pack pushes the clutch piston (6) to engage the clutch pack.

- (1) 12T Gear Clutch
- (2) Brake Pressure Plate
- (3) Brake Disc
- (4) Clutch Disc and Pressure Plate
- (5) Clutch Case
- (6) Clutch Piston
- (7) Clutch Shaft
- (8) Transmission Case

- (9) Spring
- (10) Clutch Spline Boss
- (11) PTO Clutch Valve
- (12) PTO Clutch Arm
- A : From Power Steering Controller**
- B : To Hydrostatic Transmission**
- C : To Mid and Rear PTO Shaft**

W1015610

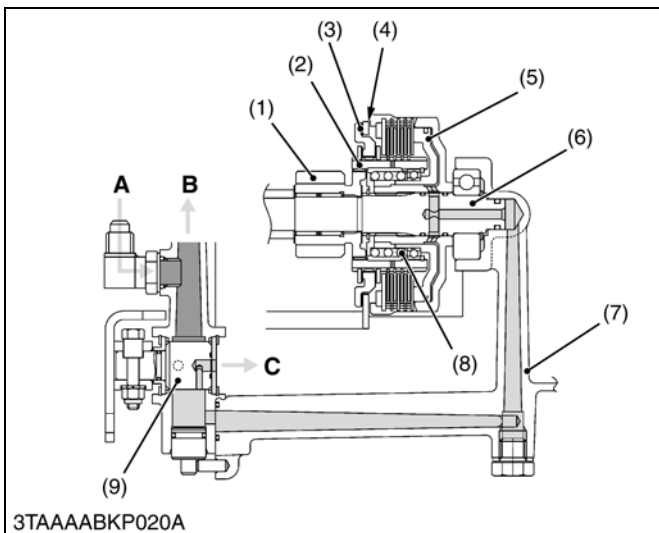

PTO Clutch "Disengaged"

When the PTO clutch lever is set at the "Disengaged" position, the PTO clutch valve (9) rotates and close the oil passage to the PTO clutch pack. The oil in the PTO clutch pack drained into the transmission case (7). Thus the clutch piston (5) is pushed back by the spring (8).

When the clutch piston (5) is pushed back, the brake pressure plate (3) is also moved to contract the brake disc (4) so as to stop the rotation and drag of the PTO shafts.

- (1) 12T Gear Clutch
- (2) Clutch Spline Boss
- (3) Brake Pressure Plate
- (4) Brake Disc
- (5) Clutch Piston
- (6) Clutch Shaft
- (7) Transmission Case
- (8) Spring
- (9) PTO Clutch Valve

- A : From Power Steering Controller**
- B : To Hydrostatic Transmission**
- C : To Transmission Case**

W1015793

[2] MID AND REAR PTO SECTION

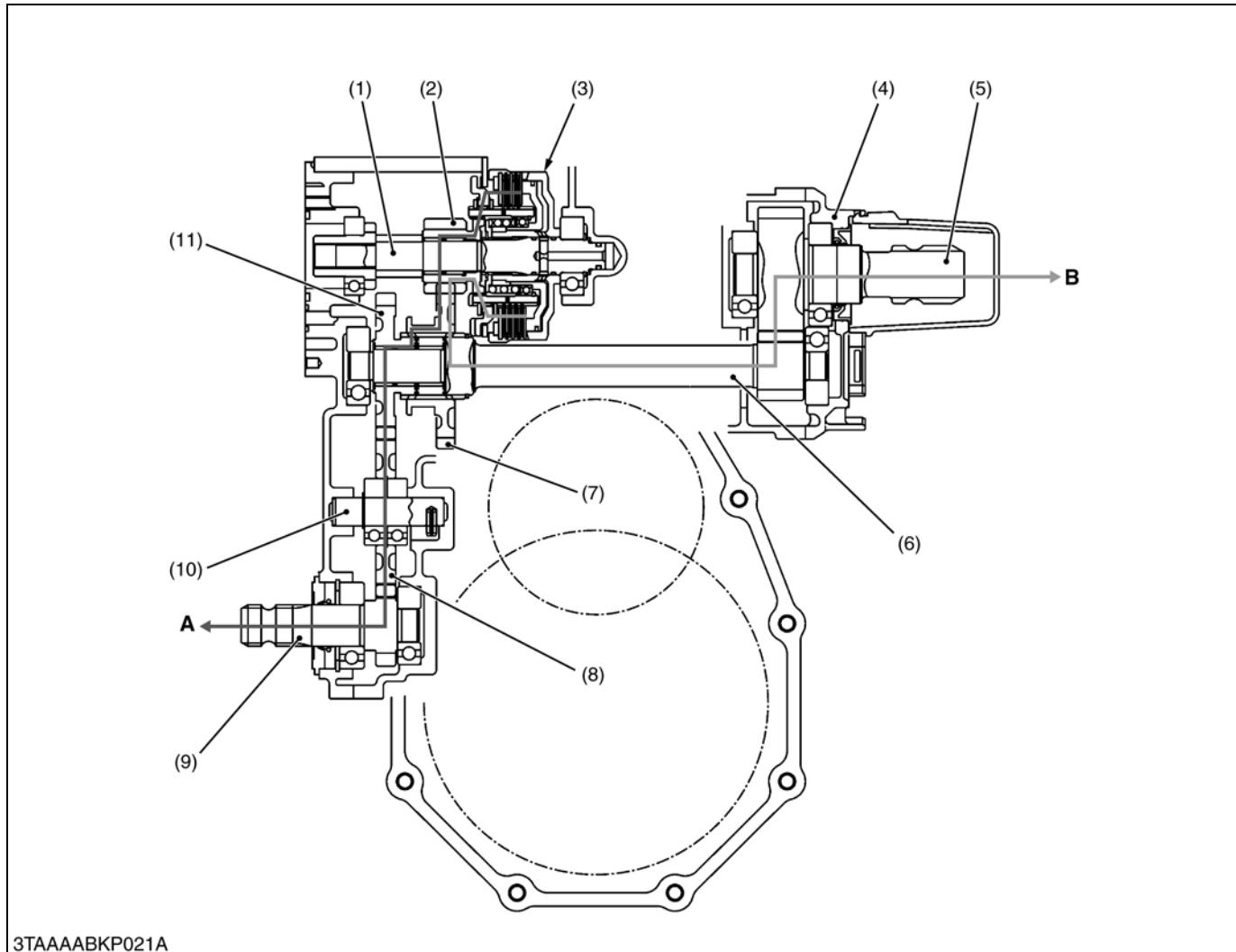

3TAAAABKP021A

- | | | | |
|---------------------|--------------------|---------------------|-----------------|
| (1) Clutch Shaft | (4) Rear Cover | (7) PTO Select Gear | (10) Idle Shaft |
| (2) 12T Gear Clutch | (5) Rear PTO Shaft | (8) 26T Idle Gear | (11) 22T Gear |
| (3) PTO Clutch Pack | (6) 11T Gear Shaft | (9) Mid-PTO Shaft | |

Three kinds of power flow are selected by operating the PTO select lever to shift the PTO select gear (7) on the 11T gear shaft (6).

■ Mid-PTO Position (A)

PTO Clutch Pack (3) → 12T Gear Clutch → PTO Select Gear (7) → 22T Gear (11) → 26T Idle Gear (8) → Mid-PTO Shaft (9).

■ Rear PTO Position (B)

PTO Clutch Pack (3) → 12T Gear Clutch (2) → PTO Select Gear (7) → 11T Gear Shaft (6) → Rear PTO Shaft (5).

■ Mid and Rear PTO Position

A and B at the same time.

4. OTHERS

[1] HYDRAULIC PUMP DRIVE GEAR SECTION

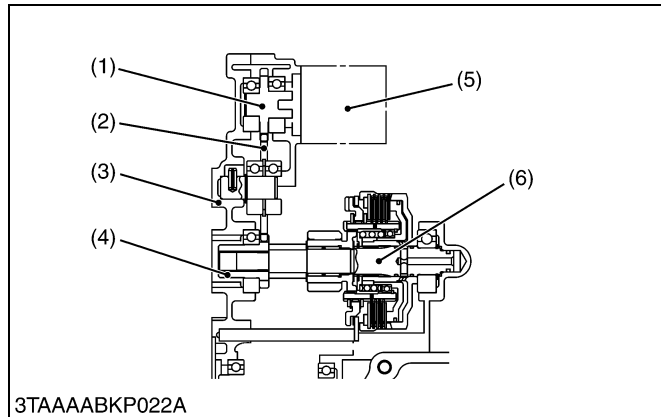

The hydraulic pump (5) is mounted to front cover (3) of the transmission case and driven by 13T gear (4) on the clutch shaft (6).

- | | |
|--------------------|--------------------|
| (1) 19T Gear Shaft | (4) 13T Gear |
| (2) 29T Idle Gear | (5) Hydraulic Pump |
| (3) Front Cover | (6) Clutch Shaft |

W1016433

SERVICING

CONTENTS

1. TROUBLESHOOTING	2-S1
2. SERVICING SPECIFICATIONS	2-S5
3. TIGHTENING TORQUES	2-S7
4. CHECKING AND ADJUSTING	2-S8
5. DISASSEMBLING AND ASSEMBLING	2-S13
[1] SEPARATING TRANSAXLE.....	2-S13
[2] HYDROSTATIC TRANSMISSION.....	2-S18
[3] TRANSMISSION CASE	2-S21
6. SERVICING	2-S29
[1] HYDROSTATIC TRANSMISSION.....	2-S29
[2] TRANSMISSION CASE	2-S30

1. TROUBLESHOOTING

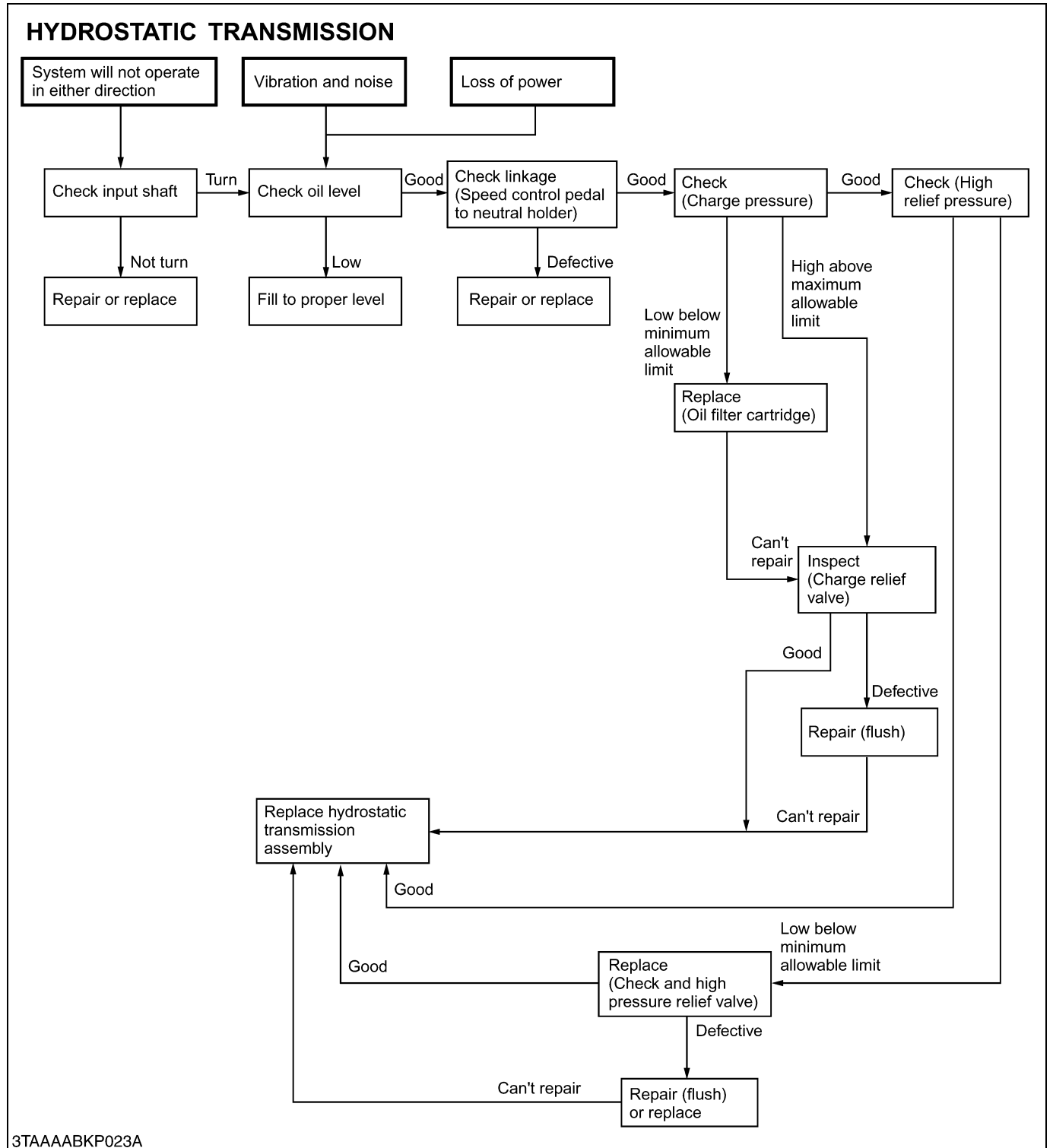

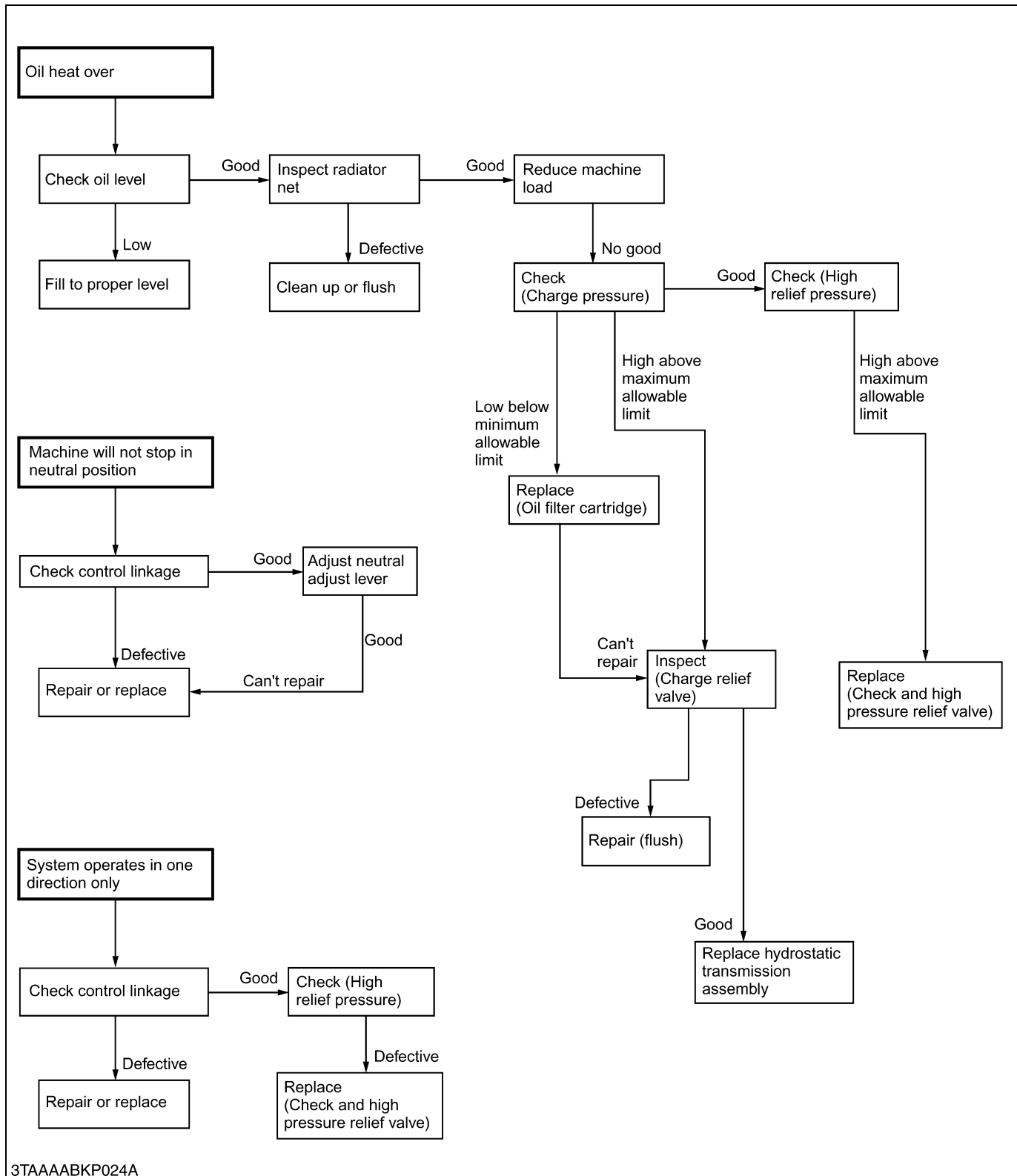

TRAVELLING GEAR SHIFT SECTION

Symptom	Probable Cause	Solution	Reference Page
Noise from Transmission	• Transmission oil insufficient	Refill	2-S13
	• Gear worn or broken	Replace	–
	• Bearings worn	Replace	–
Gear Slip Out of Mesh	• Shift fork spring tension insufficient	Replace	2-S24
	• Shift fork or shifter worn	Replace	2-S24
	• Shift fork bent	Replace	2-S24

W1013580

DIFFERENTIAL GEAR SECTION

Excessive or Unusual Noise at All Time	• Improper backlash between spiral bevel pinion and bevel gear	Adjust	2-S35
	• Improper backlash between differential pinion and differential side gear	Adjust	2-S34
	• Bearing worn	Replace	–
	• Insufficient or improper type of transmission fluid used	Replenish or change	G-7, 2-S13
Noise while Turning	• Differential pinions or differential side gears worn or damaged	Replace	2-S27
	• Differential lock binding (does not disengaged)	Replace	2-S27
	• Bearing worn	Replace	–
Differential Lock Can Not Be Set	• Differential lock shift fork damaged	Replace	2-S27
	• Differential lock shifter mounting pin damaged	Replace	2-S27
	• Differential lock pin damaged	Replace	2-S27
Differential Lock Pedal Does Not Return	• Differential lock pedal return spring weaken or damaged	Replace	2-S18
	• Differential lock fork shaft rusted	Repair	2-S27

W1013718

BRAKE SECTION

Uneven Braking Force	• Brake rod unevenly adjusted	Adjust	G-19
	• Brake disc worn	Replace	2-S36
	• Actuator warped	Replace	2-S35
Brake Drags	• Brake pedal free travel too small	Adjust	G-19
	• Ball holes of actuator for uneven wear	Replace	2-S35
	• Brake pedal return spring weaken or broken	Replace	2-S18
	• Brake cam rusted	Repair	2-S35
Poor Braking Force	• Brake pedal free travel excessive	Adjust	G-19
	• Brake disc worn	Replace	2-S36
	• Actuator warped	Replace	2-S35
	• Brake cam or lever damaged	Replace	2-S35
	• Transmission fluid improper	Change	2-S13

W1010878

PTO SECTION

Symptom	Probable Cause	Solution	Reference Page
PTO Clutch Slip	<ul style="list-style-type: none"> • Operating pressure is low • PTO clutch valve malfunctioning • Clutch disc or drive plate excessively worn • Deformation of clutch piston 	Check Repair or replace Replace Replace	2-S11 2-S23 2-S32 2-S32
PTO Shaft Does Not Rotate	<ul style="list-style-type: none"> • PTO clutch malfunctioning 	Repair or replace Engage	2-S25
PTO Clutch Operating Pressure is Low	<ul style="list-style-type: none"> • Transmission oil improper or insufficient • Relief valve malfunctioning 	Replenish or change Check or replace	2-S13 2-S12, S23
PTO Clutch Drags	<ul style="list-style-type: none"> • Brake plate excessive worn • Clutch spring weaken or broken • Deformation of pressure plate or steel plate 	Replace Replace Replace	2-S33 2-S33 2-S26

W1011002

2. SERVICING SPECIFICATIONS

Item		Factory Specification	Allowable Limit
Charge Relief Valve	Setting Pressure	294.2 to 490.4 kPa 3.0 to 5.0 kgf/cm ² 42.7 to 71.1 psi	–
Check and High Pressure Relief Valve	Setting Pressure	13.73 MPa 140 kgf/cm ² 1991.2 psi	–
PTO Clutch	Operating Pressure	961 kPa 9.8 kgf/cm ² 139.4 psi	–
Shift Fork to Shifter Gear Groove	Clearance	0.03 to 0.48 mm 0.0012 to 0.019 in.	0.7 mm 0.028 in.
13T-25T Gear to Front Wheel Drive Idle Shaft	Clearance	0.007 to 0.043 mm 0.0003 to 0.0017 in.	0.10 mm 0.0039 in.
13T-25T Gear	I.D.	19.007 to 19.020 mm 0.7483 to 0.7488 in.	–
Front Wheel Drive Idle Shaft	O.D.	13.989 to 14.000 mm 0.5507 to 0.5512 in.	–
Needle	O.D.	2.494 to 2.500 mm 0.0982 to 0.0984 in.	–
22T Gear to 11T Gear Shaft	Clearance	0.007 to 0.039 mm 0.0003 to 0.0015 in.	0.10 mm 0.0039 in.
22T Gear	I.D.	24.007 to 24.020 mm 0.9452 to 0.9457 in.	–
11T Gear Shaft	O.D.	19.987 to 20.000 mm 0.7869 to 0.7874 in.	–
Needle	O.D.	1.997 to 2.000 mm 0.0786 to 0.0787 in.	–
12T Gear Clutch to Clutch Shaft	Clearance	0.007 to 0.037 mm 0.0003 to 0.0015 in.	0.10 mm 0.0039 in.
12T Gear Clutch	I.D.	22.007 to 22.020 mm 0.8664 to 0.8669 in.	–
Clutch Shaft	O.D.	17.989 to 18.000 mm 0.7082 to 0.7087 in.	–
Needle	O.D.	1.997 to 2.000 mm 0.0786 to 0.0787 in.	–

W1013874

Item		Factory Specification	Allowable Limit
PTO Clutch Disc	Thickness	1.70 to 1.90 mm 0.067 to 0.075 in.	1.55 mm 0.061 in.
Pressure Plate	Thickness	1.95 to 2.05 mm 0.077 to 0.081 in.	1.80 mm 0.071 in.
Steel Plate	Thickness	1.15 to 1.25 mm 0.045 to 0.049 in.	1.10 mm 0.043 in.
Clutch Piston	Flatness	–	0.15 mm 0.0059 in.
Pressure Plate and Steel Plate	Flatness	–	0.20 mm 0.0079 in.
Clutch Spring	Free Length	37.3 to 37.7 mm 1.47 to 1.48 in.	34.5 mm 1.36 in.
PTO Brake Disc	Thickness	3.20 to 3.40 mm 0.126 to 0.134 in.	3.00 mm 0.118 in.
Differential Case to Differential Side Gear	Clearance	0.050 to 0.151 mm 0.0020 to 0.0059 in.	0.30 mm 0.0118 in.
Differential Case	I.D.	38.000 to 38.062 mm 1.4961 to 1.4985 in.	–
Differential Side Gear	O.D.	37.911 to 37.950 mm 1.4926 to 1.4941 in.	–
Differential Pinion Shaft to Differential Pinion	Clearance	0.080 to 0.122 mm 0.0031 to 0.0048 in.	0.30 mm 0.0118 in.
Differential Pinion	I.D.	20.060 to 20.081 mm 0.7898 to 0.7906 in.	–
Differential Pinion Shaft	O.D.	19.959 to 19.980 mm 0.7858 to 0.7866 in.	–
Differential Pinion to Differential Side Gear	Backlash	0.15 to 0.30 mm 0.0059 to 0.0118 in.	0.40 mm 0.0157 in.
Spiral Bevel Pinion Shaft	Side Clearance	0.1 to 0.3 mm 0.0039 to 0.0118 in.	–
Spiral Bevel Pinion Shaft to Spiral Bevel Gear	Backlash	0.1 to 0.3 mm 0.0039 to 0.0118 in.	–
Actuator and Bearing Holder	Flatness	–	0.30 mm 0.0118 in.
Cam Plate and Ball	Height	22.89 to 22.99 mm 0.9012 to 0.9051 in.	22.40 mm 0.8819 in.
Brake Disc	Thickness	3.3 to 3.5 mm 0.130 to 0.138 in.	3.0 mm 0.118 in.
Friction Plate	Thickness	1.92 to 2.08 mm 0.0756 to 0.0819 in.	1.52 mm 0.0598 in.

W1013874

3. TIGHTENING TORQUES

Tightening torques of screws, bolts and nuts on the table below are especially specified.
 (For general use screws, bolts and nuts : See page G-8.)

Item	N-m	kgf-m	ft-lbs
Charge relief valve checking plug	21.58 to 25.50	2.2 to 2.6	15.91 to 18.81
Hexagon socket head plug (P1 and P2 port)	40.70 to 94.93	4.15 to 9.68	30.02 to 70.02
PTO clutch operating pressure plug	21.58 to 25.50	2.2 to 2.6	15.91 to 18.81
ROPS mounting nut	124 to 147	12.6 to 15.0	91.2 to 108
Rear wheel mounting screw	108.5 to 130.2	11.1 to 13.2	80 to 96
Fuel tank stay mounting bolt and nut	48.1 to 55.9	4.9 to 5.7	35.4 to 41.2
Stopper plate mounting bolt and nut	77.5 to 90.2	7.9 to 9.2	57.1 to 66.5
PTO cover RH and LH mounting bolt and nut	48.1 to 55.9	4.9 to 5.7	35.4 to 41.2
Rear support mounting screw	77.5 to 90.2	7.9 to 9.2	57.1 to 66.5
Hitch plate mounting bolt and nut	124 to 147	12.6 to 15.0	91.2 to 108
Fender bracket mounting bolt and nut	124 to 147	12.6 to 15.0	91.2 to 108
Fender center stay mounting screw	124 to 147	12.6 to 15.0	91.2 to 108
Front coupling mounting screw	23.5 to 27.5	2.4 to 2.8	17.4 to 20.3
HST fan mounting screw	9.8 to 11.3	1.00 to 1.15	7.2 to 8.3
Tie-rod mounting screw	124 to 147	12.6 to 15.0	91.2 to 108
Transaxle assembly mounting screw (M12)	62.8 to 72.6	6.4 to 7.4	46.3 to 53.5
Transaxle assembly mounting screw (M14)	124 to 147	12.6 to 15.0	91.2 to 108
Rear coupling mounting screw	23.5 to 27.5	2.4 to 2.8	17.4 to 20.3
Hydraulic control lever mounting bolt and nut	17.7 to 20.6	1.8 to 2.1	13.0 to 15.2
Trunnion arm mounting bolt and nut	9.8 to 11.3	1.00 to 1.15	7.2 to 8.3
Hydrostatic transmission mounting screw	15.7 to 20.6	1.6 to 2.1	11.6 to 15.2
Center section mounting hex. head socket screw	39.2 to 44.1	4.0 to 4.5	28.9 to 32.5
Charge relief valve plug	14.22 to 23.54	1.45 to 2.40	10.49 to 17.36
Check and high pressure relief valve plug	40.70 to 94.93	4.15 to 9.68	30.02 to 70.02
Delivery pipe	28.4 to 30.0	2.9 to 3.1	20.9 to 22.1
PTO safety switch mounting screw	17.7 to 20.6	1.8 to 2.1	13.0 to 15.2
Hydraulic cylinder mounting screw	39.2 to 44.1	4.0 to 4.5	28.9 to 32.5
Front cover mounting screw	39.2 to 44.1	4.0 to 4.5	28.9 to 32.5
PTO clutch arm mounting bolt and nut	9.8 to 14.7	1.00 to 1.15	7.2 to 10.8
PTO relief valve plug	21.58 to 25.50	2.2 to 2.6	15.91 to 18.81
Rear cover mounting screw	39.2 to 44.1	4.0 to 4.5	28.9 to 32.5
PTO select bolt	21.6 to 25.5	2.2 to 2.6	15.9 to 18.8
Bracket mounting nut	77.5 to 90.1	7.9 to 9.2	57.2 to 66.5
Axle cover mounting screw	39.2 to 44.1	4.0 to 4.5	28.9 to 32.5
66T final gear mounting screw	60.8 to 70.6	6.2 to 7.2	44.8 to 52.1

W1012736

4. CHECKING AND ADJUSTING

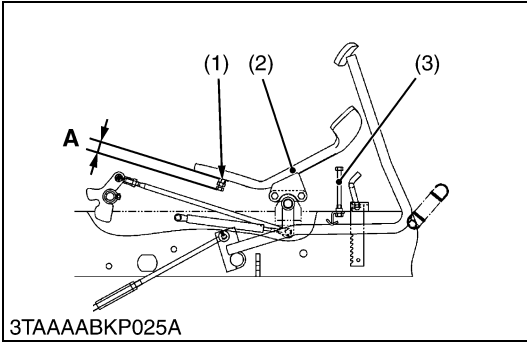

Adjusting Maximum Speed

■ Forward

1. Depress the speed control pedal (2) all the way and lengthen the stopper bolt (3) until it touches the bottom surface of the speed control pedal (2).
2. Release the speed control pedal (2) to the neutral, lengthen the stopper bolt (3) half turn and lock it.

■ Reverse

1. Adjust the stopper bolt (1) length "A" to 30 mm (1.18 in.) and lock it securely.

(Reference)

Maximum speed	Reference	Forward	13.0 to 14.0 km/h 8.1 to 8.8 mph
		Reverse	10.0 to 11.0 km/h 6.3 to 6.9 mph

- (1) Stopper Bolt (Reverse)
(2) Speed Control Pedal

- (3) Stopper Bolt (Forward)

W1012590

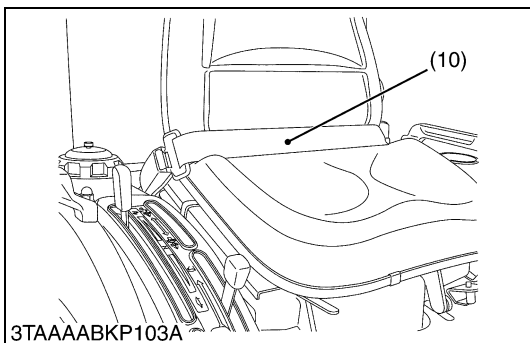
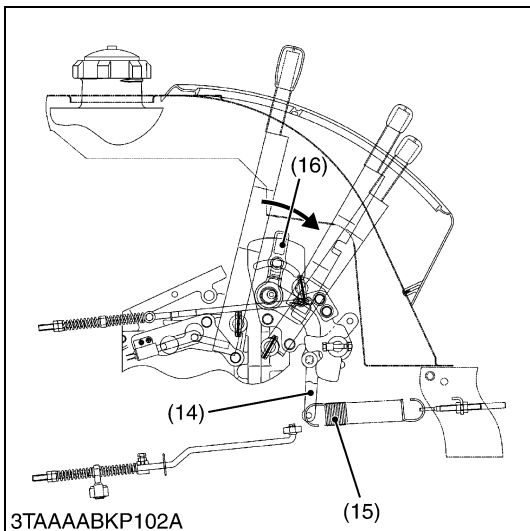
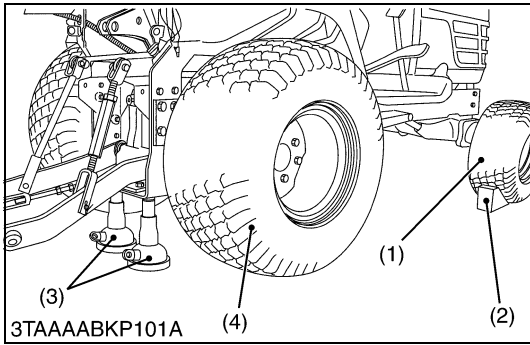
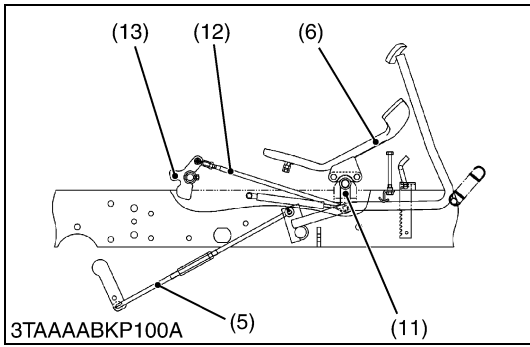

Preparation before HST Adjustment

CAUTION

- **Park the machine on a firm and level ground.**
- 1. Place the wooden blocks (2) at F and R side of wheels not to move the tractor.
- 2. Measure the speed control pedal (6) control force with a push-pull gauge before starting the engine.
- 3. Remove the brake rod (5) because improper brake rod adjustment will cause the HST neutral adjustment unexpectedly.
- 4. Remove the neutral spring (15) from the neutral arm (14). Move the neutral arm (14) by hand. Check that the neutral arm (14) moves smoothly around the neutral adjust lever (16). If the neutral arm (14) does not move smoothly around neutral adjust lever (16), apply spray grease to neutral arm fulcrum contacted to the neutral arm (14). Check it again. If the neutral arm (14) still does not move smoothly, change the neutral arm (14) with a new one. Reinstall the neutral spring (15) to the original position.
- 5. Lift up the rear wheels (4) with safely by the hydraulic jacks (3).
- 6. Shift the front wheel drive lever (7) to “OFF” position (8).
- 7. To avoid the engine stopping in adjusting neutral and to contact the operator’s seat switch, fasten firmly seat belt (10) on the operator’s seat as shown in the figure. (for only model equipped Operator’s Presence Control System.)

Speed control pedal control force (forward side pedal)	Factory spec.	60 to 100 N 6.1 to 10.2 kgf 13.5 to 22.8 lbs
Speed control pedal control force (reverse side pedal)	Factory spec.	40 to 80 N 4.1 to 8.2 kgf 9.0 to 18.0 lbs

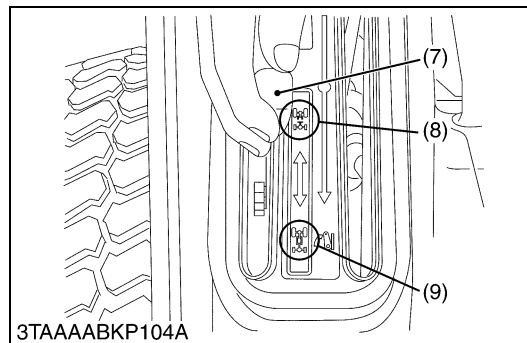

- (1) Front Wheel
- (2) Wooden Block
- (3) Hydraulic Jack
- (4) Rear Wheel
- (5) Brake Rod
- (6) Speed Control Pedal
- (7) Front Wheel Drive Lever
- (8) 4WD “OFF” Position
- (9) 4WD “ON” Position
- (10) Seat Belt
- (11) Speed Control Pedal Link
- (12) Speed Control Rod
- (13) Trunnion Arm
- (14) Neutral Arm
- (15) Neutral Spring
- (16) Neutral Adjust Lever

W1047776

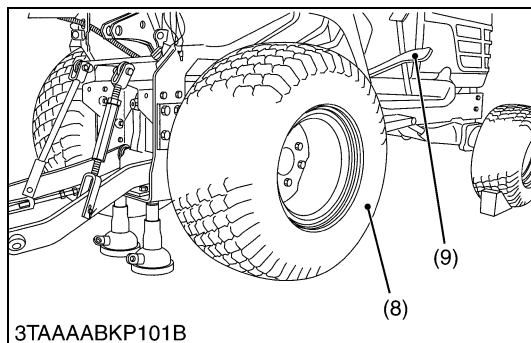
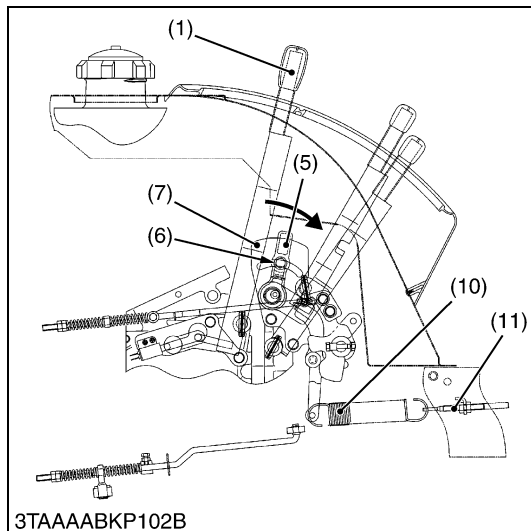
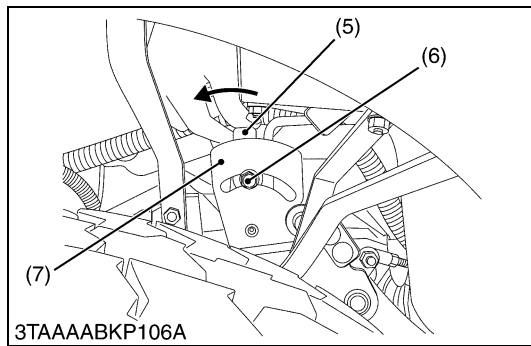
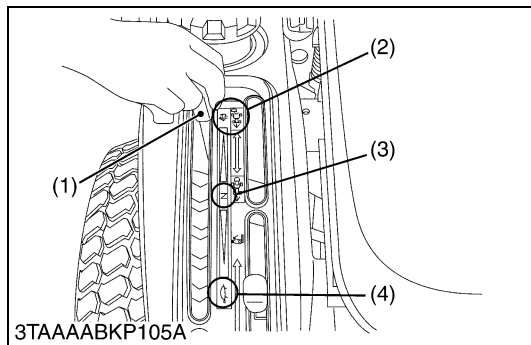

Adjustment of HST Neutral Position

1. Start the engine.
2. Shift the range gear shift lever (1) to **“Hi”** position (2).
3. Loosen the locking screw (6). And push the neutral adjust lever (5) toward the tractor rear side as shown in the figure until the rear wheels (4) begin to rotate forward.
4. Push the neutral adjust lever (5) toward tractor front side until the rear wheels (4) stop rotating.
5. When the rear wheels (4) stop rotating, lock the neutral adjust lever (5) with the locking screw (6).
6. Depress the speed control pedal (9) forward to rotate the rear wheels (8), release the foot from the speed control pedal (9) and check that the rear wheels (8) stop rotating.
7. Depress the speed control pedal (9) reverse to rotate the rear wheels (8), release the foot from the speed control pedal (9) and check that the rear wheels (8) stop rotating.
If the rear wheels (8) do not stop rotating, repeat the above mentioned procedure 3 to 5 again and check that the rear wheels (8) stop rotating at the neutral position of the speed control pedal (9).
8. Shift the range gear shift lever (1) to **“LOW”** position. Check that the rear wheels (8) stop rotating at the neutral position of the speed control pedal (9).
9. Reinstall the brake rod to the original position.
10. Remove the hydraulic jacks.
11. Disconnect the safety belt to return the operator’s seat switch to the original condition. (for only model equipped Operator’s Presence Control System.)
12. Check the HST proper operation on the usual jobs.

- | | |
|-------------------------------|-------------------------|
| (1) Range Gear Shift Lever | (7) Neutral Plate |
| (2) “Hi” Position | (8) Rear Wheel |
| (3) “NEUTRAL” Position | (9) Speed Control Pedal |
| (4) “Lo” Position | (10) Neutral Spring |
| (5) Neutral Adjust Lever | (11) Adjust Rod |
| (6) Locking Screw | |

W1012819

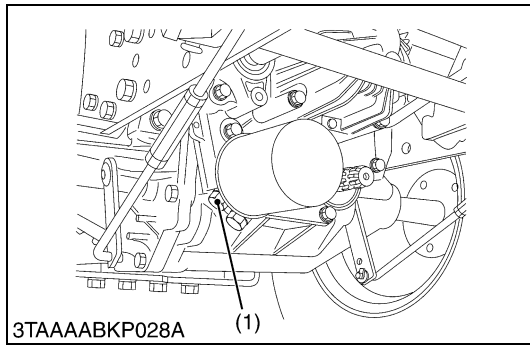

Charge Relief Pressure

⚠ CAUTION

- **When checking, park the tractor on flat ground, apply the parking brake.**
1. Remove the plug (M14, Pitch 1.5 mm) (1) from the front cover, then install the adaptor, cable and pressure gauge.
 2. Set the range gear shift lever to **Neutral** position.
 3. Start the engine and run it at the maximum speed.
 4. Read the pressure gauge to measure the charge relief pressure.
 5. If the measurement is not within the factory specifications, check the charge relief valve and related hydraulic components.

Charge relief pressure	Factory spec. (Oil temperature at 50 °C, 122 °F)	294.2 to 490.4 kPa 3.0 to 5.0 kgf/cm ² 42.7 to 71.1 psi
------------------------	--	--

Tightening torque	Plug	21.58 to 25.50 N·m 2.2 to 2.6 kgf·m 15.91 to 18.81 ft-lbs
-------------------	------	---

(1) Plug

W1013009

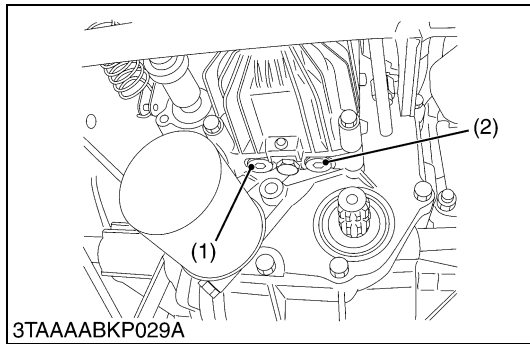

High Relief Pressure

⚠ CAUTION

- **When checking, park the tractor on flat ground, apply the parking brake.**
1. Remove the hexagon socket head plug (3/4-16 UNF-2A) from **P1** (1) or **P2** (2), then install the adaptor, cable and pressure gauge.
 2. Start the engine and run it at maximum speed.
 3. Set the range gear shift lever to **High** position.
 4. Depress the speed control pedal to **forward** or **reverse**, and read the pressure gauge to measure the high relief pressure.
 5. If the measurement is not same as factory specification, check the high pressure relief valve and related hydraulic components.

High relief pressure	Factory spec. (Oil temperature at 50 °C, 122 °F)	13.73 MPa 140 kgf/cm ² 1991.2 psi
----------------------	--	--

Tightening torque	Hexagon socket head plug (P1 and P2 port)	40.70 to 94.93 N·m 4.15 to 9.68 kgf·m 30.02 to 70.02 ft-lbs
-------------------	---	---

■ IMPORTANT

- **Measure quickly so that the high pressure relief valve may not be in operation more than 10 seconds.**

■ NOTE

- **When reinstall the hexagon socket head plug, take care not to damage the O-ring.**

(1) P1 Port (Reverse)

(2) P2 Port (Forward)

W1013275

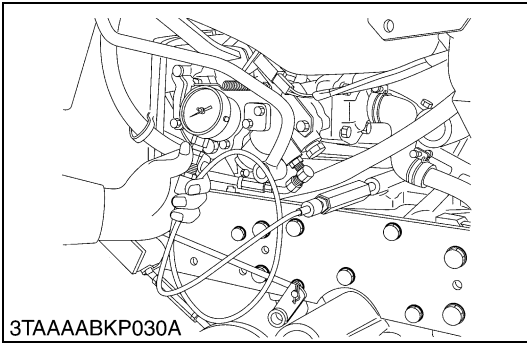

PTO Clutch Operating Pressure

⚠ CAUTION

- **When checking, park the tractor on flat ground, apply the parking brake.**

1. Lift the rear of the tractor and remove the left rear wheel.
2. Remove the plug (M14, Pitch 1.5 mm), then install the adaptor, cable and pressure gauge.
3. Start the engine and set at maximum speed.
4. Move the PTO clutch lever to “**Engaged**” position, and measure the pressure.
5. If the measurement is not same as factory specifications, check the PTO relief valve and related hydraulic components.

■ IMPORTANT

- **Do not connect the universal joint of the implement to the mid and rear PTO shaft.**

PTO clutch operating pressure	Factory spec.	961 kPa 9.8 kgf/cm ² 139.4 psi
-------------------------------	---------------	---

Tightening torque	Plug	21.58 to 25.50 N·m 2.2 to 2.6 kgf·m 15.91 to 18.81 ft-lbs
-------------------	------	---

Condition

- Engine speed : Maximum
- Oil temperature : 45 to 55 °C
113 to 131 °F

W1013552

Brake Pedal Free Travel

1. See page G-19.

W1013715

5. DISASSEMBLING AND ASSEMBLING

[1] SEPARATING TRANSAXLE

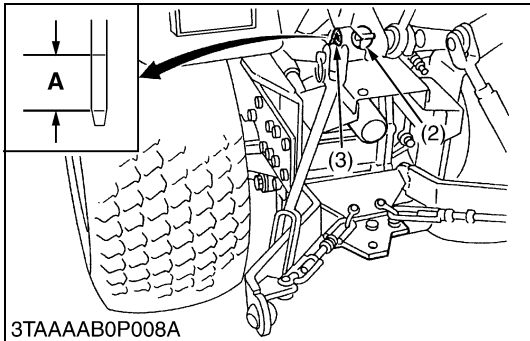
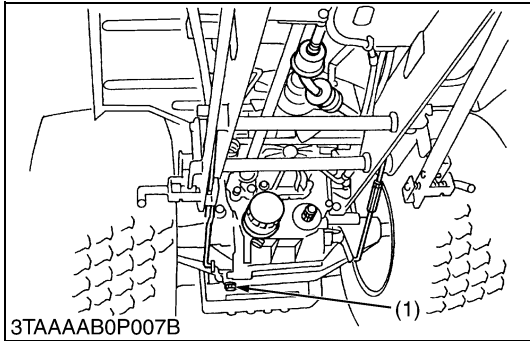

Draining Transmission Fluid

⚠ CAUTION

- Be sure to stop the engine before checking and changing the transmission fluid.

1. Place oil pan under the tractor.
2. Remove the drain plugs (1) at the bottom of the transmission case.
3. Drain the transmission fluid and reinstall the drain plug.

(When refilling)

- Fill new oil from filling port after removing the filling plug (2) up to the upper notch on the dipstick (3).
- After running the engine for few minutes, stop it and check the oil level again, if low, add oil to prescribed level.

■ IMPORTANT

- Use only multi-grade transmission oil. Use of other oils may damage the transmission or hydraulic system. Refer to “LUBRICANTS, FUEL AND COOLANT”. (See page G-7.)
- Never work the tractor immediately after changing the transmission oil. Keeping the engine at medium speed for a few minutes to prevents damage to the transmission.
- Do not mix different brands oil together.

Transmission fluid capacity	10.1 L 2.7 U.S.gals. 2.2 Imp.gals.
-----------------------------	--

- (1) Drain Plug
- (2) Filling Plug
- (3) Dipstick

A : Oil level is acceptable within this range

W1014039

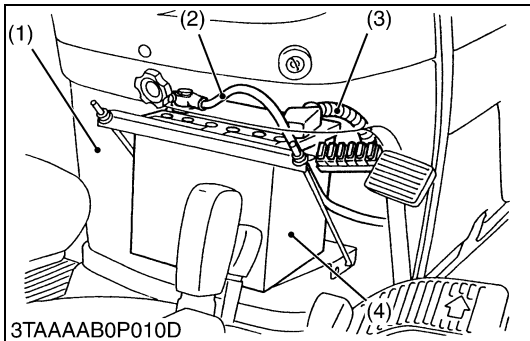

Battery

⚠ CAUTION

- When disconnecting the battery cables, disconnect the negative cable from the battery first. When connecting, connect the positive cable to the battery first.

1. Remove the under panel (1).
2. Disconnect the negative cable (2) from the battery.
3. Disconnect the positive cable (3) from the battery and remove the battery (4).

- (1) Under Panel
- (2) Negative Cable
- (3) Positive Cable
- (4) Battery

W1032888

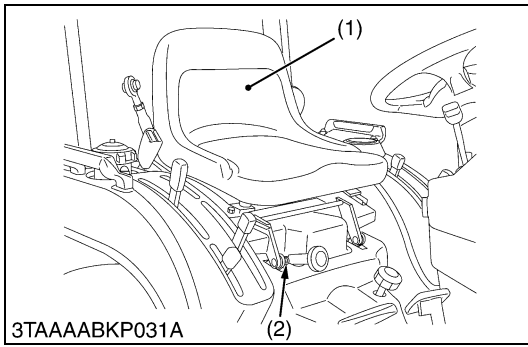

Seat

1. Remove the snap pin (2) to remove the seat (1).

- (1) Seat
- (2) Snap Pin

W1014409

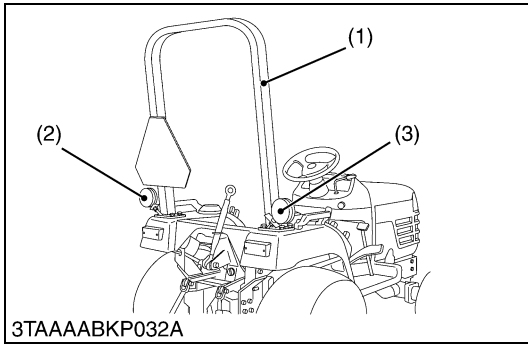

Roll-Over Protective Structures (ROPS)

1. Disconnect the lead wires from the hazard lights (2), (3).
2. Remove the ROPS mounting nuts and remove the ROPS (1).

(When reassembling)

Tightening torque	ROPS mounting nut	124 to 147 N·m 12.6 to 15.0 kgf·m 91.2 to 108 ft-lbs
-------------------	-------------------	--

- (1) ROPS
- (2) Hazard Light LH
- (3) Hazard Light RH

W1014508

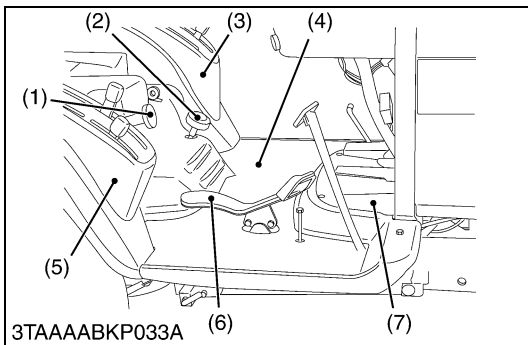

Speed Control Pedal, Lever Guides and Step

1. Remove the lowering speed adjusting knob (1) and cutting height adjusting dial knob (2).
2. Remove the step plate (7), speed control pedal (6) and lever guides (3), (5).
3. Remove the step (4).

- (1) Lowering Speed Adjusting Knob
- (2) Cutting Height Adjusting Dial Knob
- (3) Lever Guide LH
- (4) Step
- (5) Lever Guide RH
- (6) Speed Control Pedal
- (7) Step Plate

W1014726

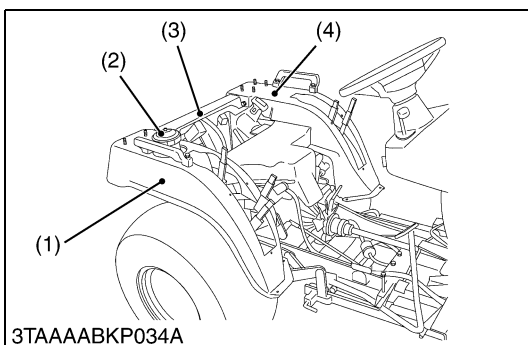

Fenders

1. Disconnect the lead wires from the tail lights.
2. Remove the fuel cap (2), then remove the fenders (1), (3) and (4) as a unit.
3. Replace the fuel cap (2).

- (1) Fender RH
- (2) Fuel Cap
- (3) Rear Fender
- (4) Fender LH

W1014865

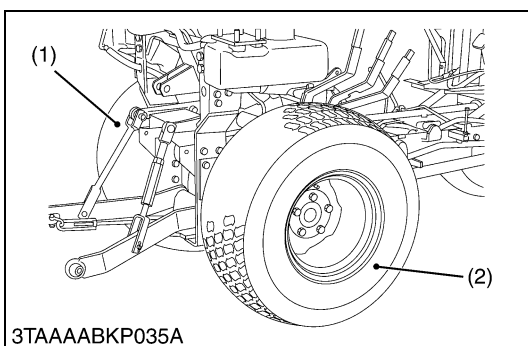

Rear Wheel

1. Remove the rear wheels (1) and (2).

(When reassembling)

Tightening torque	Rear wheel mounting screw	108.5 to 130.2 N·m 11.1 to 13.2 kgf·m 80 to 96 ft-lbs
-------------------	---------------------------	---

- (1) Rear Wheel LH
- (2) Rear Wheel RH

W1014976

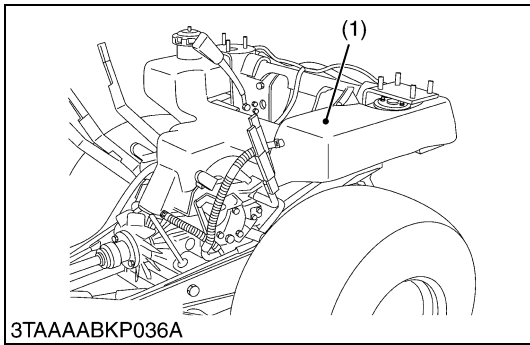

Fuel Tank

1. Drain the fuel.
2. Disconnect the lead wire from fuel level sensor and fuel hoses from the fuel tank (1).
3. Remove the fuel tank stays (2), (3) and cushions, then remove the fuel tank (1).

(When reassembling)

Tightening torque	Fuel tank stay mounting bolt and nut	48.1 to 55.9 N·m 4.9 to 5.7 kgf·m 35.4 to 41.2 ft·lbs
-------------------	--------------------------------------	---

- (1) Fuel Tank
 (2) Fuel Tank Stay LH
 (3) Fuel Tank Stay RH

W1015094

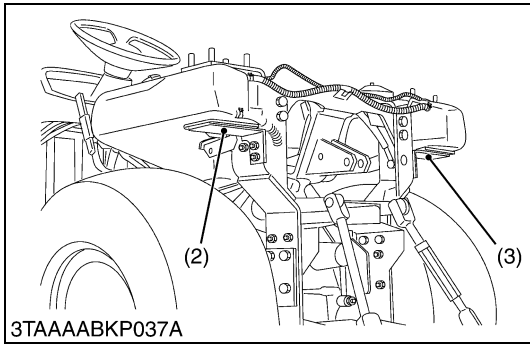

Lift Rod and Lower Link

1. Remove the lift rods (1) and (4).
2. Remove the stopper plate LH (5), then tap out the lower link pin to remove the lower links (2), (3) with check chains as a unit.

(When reassembling)

Tightening torque	Stopper plate mounting bolt and nut	77.5 to 90.2 N·m 7.9 to 9.2 kgf·m 57.1 to 66.5 ft·lbs
-------------------	-------------------------------------	---

- (1) Lift Rod RH
 (2) Lower Link RH
 (3) Lower Link LH
 (4) Lift Rod LH
 (5) Stopper Plate

W1023959

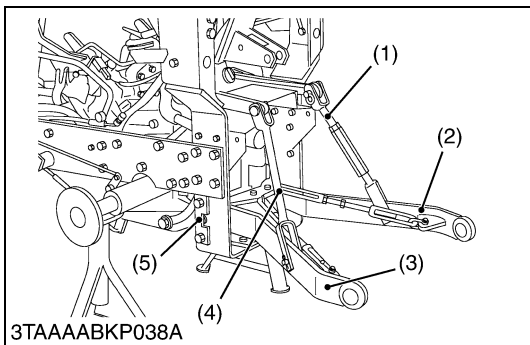

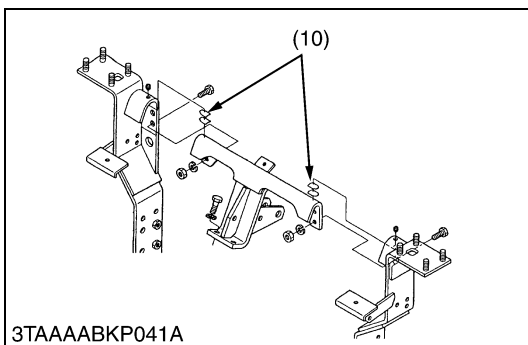
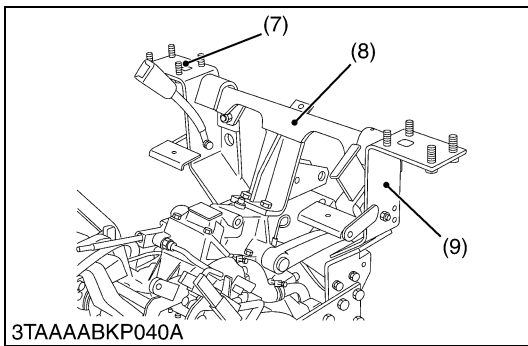
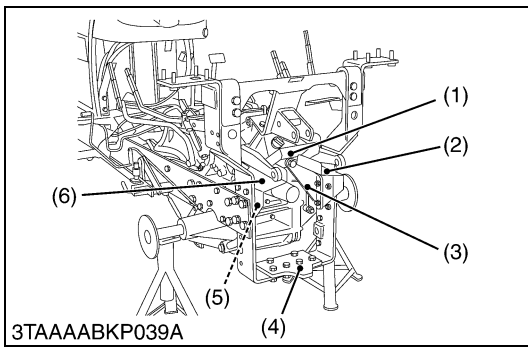

PTO Cover, Fender Bracket, Hitch Plate and Others

1. Remove the PTO covers (1), (2) and (6).
2. Remove the hitch plate (4) and rear supports (3), (5).
3. Remove the fender brackets (7), (9), shim (10) and fender center stay (8).

(When reassembling)

- Do not firmly tighten all screws, bolts and nuts until most components are attached.
- After the all screws, bolts and nuts are tighten to the specified torque, install and secure the shim (10) with hexagonal socket head screw between fender brackets (7), (9) and fender center stay (8).
- When tightening the upper PTO cover (1) mounting bolts and nuts, adjust the operating force to 29.4 to 49.0 N (3.0 to 5.0 kgf, 6.6 to 11.0 lbs).

Tightening torque	PTO cover RH and LH mounting bolt and nut	48.1 to 55.9 N·m 4.9 to 5.7 kgf·m 35.4 to 41.2 ft-lbs
	Rear support mounting screw (M12)	77.5 to 90.2 N·m 7.9 to 9.2 kgf·m 57.1 to 66.5 ft-lbs
	Hitch plate mounting bolt and nut (M14)	124 to 147 N·m 12.6 to 15.0 kgf·m 91.2 to 108 ft-lbs
	Fender bracket mounting bolt and nut (M14)	124 to 147 N·m 12.6 to 15.0 kgf·m 91.2 to 108 ft-lbs
	Fender center stay mounting screw (M14)	124 to 147 N·m 12.6 to 15.0 kgf·m 91.2 to 108 ft-lbs

(Reference)

- Thickness of shim (10) : 1.2 mm (0.047 in.)
1.5 mm (0.059 in.)
1.9 mm (0.075 in.)

- | | |
|---------------------|------------------------|
| (1) Upper PTO Cover | (6) PTO Cover LH |
| (2) PTO Cover RH | (7) Fender Bracket RH |
| (3) Rear Support RH | (8) Fender Center Stay |
| (4) Hitch Plate | (9) Fender Bracket LH |
| (5) Rear Support LH | (10) Shim |

W1024983

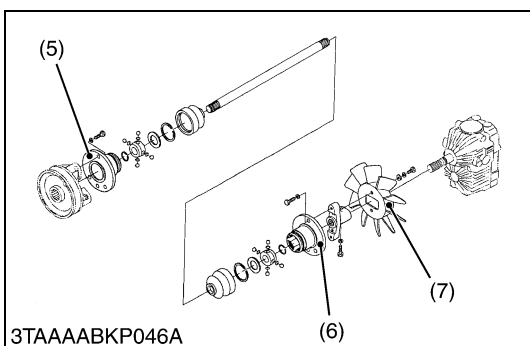
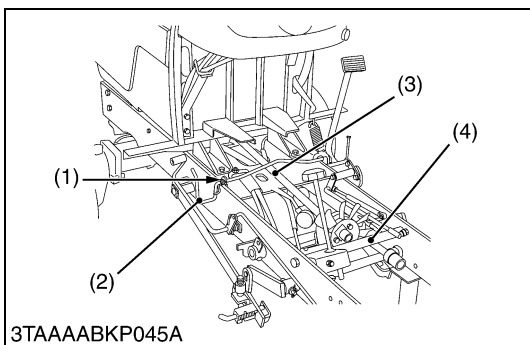
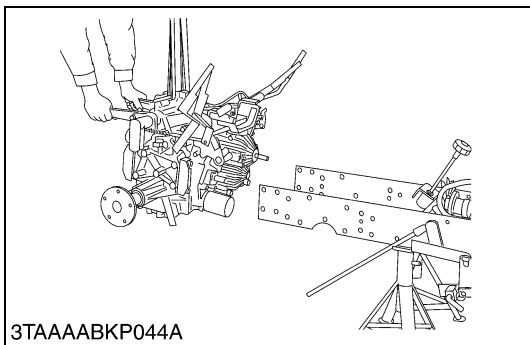
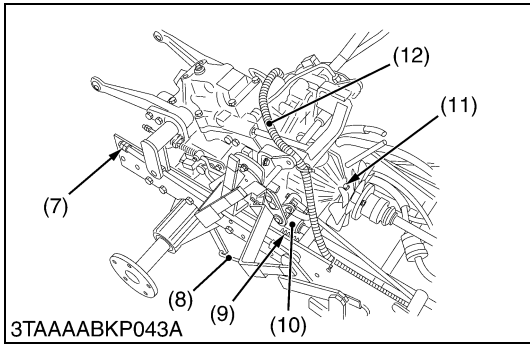
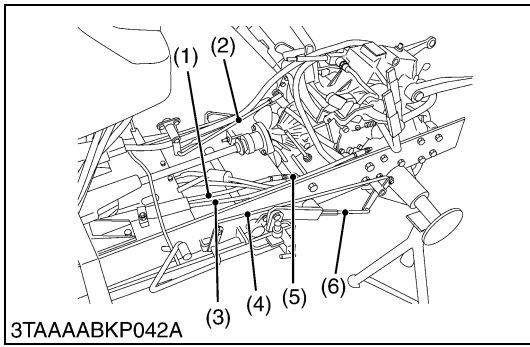

Transaxle Assembly

1. Disconnect the speed control rod (2), differential lock rod (4) and brake rod (6), (8).
2. Remove the rear coupling mounting bolt (11) and spring (9).
3. Remove the nuts from the lift link rear (7) and wire harness (12) clamps.
4. Disconnect the power steering delivery hose (3).
5. Disconnect the return hose (1) and remove the pipe (5).
6. Hold the transaxle assembly with nylon strap and crane.
7. Remove the transaxle assembly mounting screws and separate it.

(When reassembling)

- Tighten the smaller screws (M12) first.

Tightening torque	Transaxle assembly mounting screw (M12)	62.8 to 72.6 N-m 6.4 to 7.4 kgf-m 46.3 to 53.5 ft-lbs
	Transaxle assembly mounting screw (M14)	124 to 147 N-m 12.6 to 15.0 kgf-m 91.2 to 108 ft-lbs
	Rear coupling mounting screw	23.5 to 27.5 N-m 2.4 to 2.8 kgf-m 17.4 to 20.3 ft-lbs

- | | |
|----------------------------------|----------------------------------|
| (1) Return Hose | (7) Nut |
| (2) Speed Control Rod | (8) Brake Rod RH |
| (3) Power Steering Delivery Hose | (9) Spring |
| (4) Differential Lock Rod | (10) Front Wheel Drive Shaft |
| (5) Pipe | (11) Rear Coupling Mounting Bolt |
| (6) Brake Rod LH | (12) Wire Harness |

W1016000

Parking Pedal, Propeller Shaft Assembly and Tie-rod

1. Unhook the spring (1) and remove the parking pedal (2).
2. Disconnect the front coupling (5) and remove the propeller shaft assembly (3).
3. Remove the HST fan (7) from propeller shaft assembly (3).
4. Remove the tie-rod (4).

(When reassembling)

- Apply grease to inside of the front coupling and rear coupling.

Tightening torque	Front coupling mounting screw	23.5 to 27.5 N-m 2.4 to 2.8 kgf-m 17.4 to 20.3 ft-lbs
	HST fan mounting screw	9.8 to 11.3 N-m 1.00 to 1.15 kgf-m 7.2 to 8.3 ft-lbs
	Tie-rod mounting screw	124 to 147 N-m 12.6 to 15.0 kgf-m 91.2 to 108 ft-lbs

- | | |
|------------------------------|--------------------|
| (1) Spring | (5) Front Coupling |
| (2) Parking Pedal | (6) Rear Coupling |
| (3) Propeller Shaft Assembly | (7) HST Fan |
| (4) Tie-rod | |

W1016476

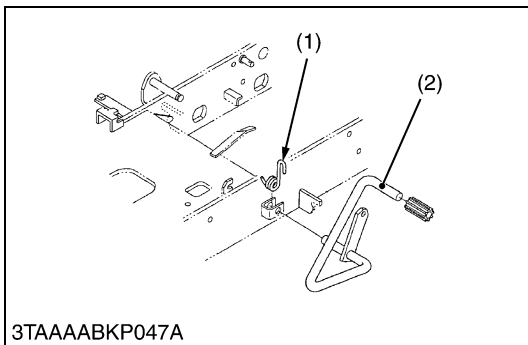

3TAAAABKP047A

Differential Lock Pedal

1. Unhook the spring (1) and remove the differential lock pedal (2).

- (1) Spring
- (2) Differential Lock Pedal

W1016728

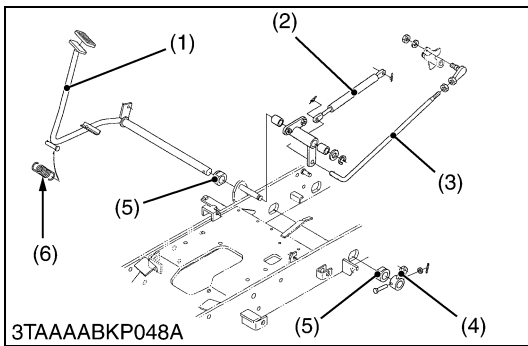

3TAAAABKP048A

Brake Pedal, Speed Change Rod and HST Damper

1. Remove the cotter pin and clevis pin, then remove the brake arm (4).
2. Remove the spring (6), brake pedal (1) and bushes (5).
3. Remove the rue rings, then remove the HST damper (2) and speed change rod (3).

- (1) Brake Pedal
- (2) HST Damper
- (3) Speed Change Rod
- (4) Brake Arm
- (5) Bush
- (6) Spring

W1016858

[2] HYDROSTATIC TRANSMISSION

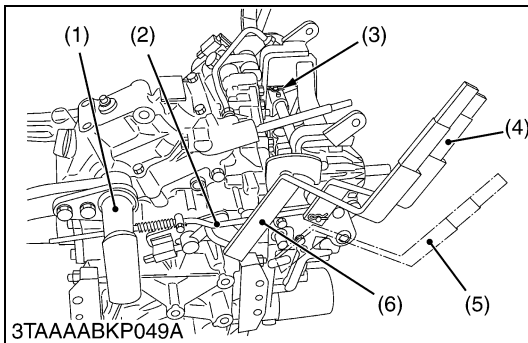

3TAAAABKP049A

Levers and Mower Lift Arm

1. Tap out the spring pin from the range gear shift lever (6) and front wheel drive lever (5), then remove the both levers.
2. Remove the mower lift arm (1) with feedback rod (2).
3. Remove the rue ring (3) and hydraulic control lever mounting bolt and nut, then remove the hydraulic control lever (4).

(When reassembling)

Tightening torque	Hydraulic control lever mounting bolt and nut	17.7 to 20.6 N·m 1.8 to 2.1 kgf·m 13.0 to 15.2 ft·lbs
-------------------	---	---

- (1) Mower Lift Arm
- (2) Feedback Rod
- (3) Rue Ring
- (4) Hydraulic Control Lever
- (5) Front Wheel Drive Lever
- (6) Range Gear Shift Lever

W1017118

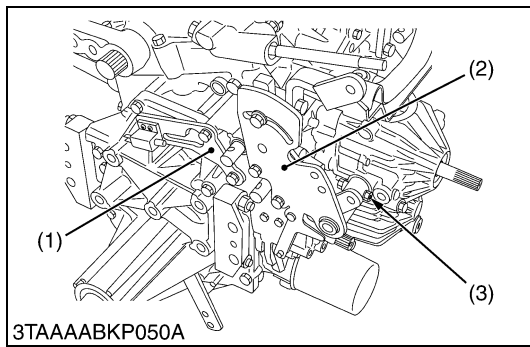

Neutral Plate and Neutral Switch Stay

1. Remove the trunnion arm mounting bolt and nut (3).
2. Remove the neutral plate mounting screws, then remove the neutral plate (2).
3. Remove the neutral switch stay (1).

(When reassembling)

Tightening torque	Trunnion arm mounting bolt and nut	9.8 to 11.3 N·m 1.00 to 1.15 kgf·m 7.2 to 8.3 ft-lbs
-------------------	------------------------------------	--

- (1) Neutral Switch Stay (2) Neutral Plate (3) Trunnion Arm Mounting Bolt and Nut

W1017287

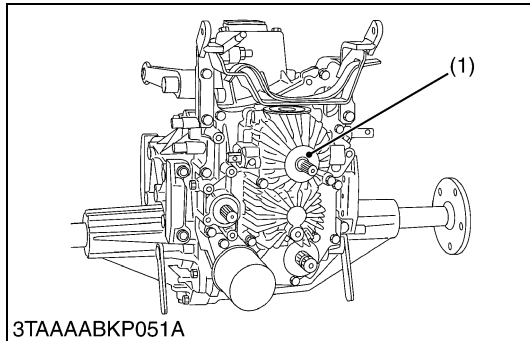

Hydrostatic Transmission Assembly

1. Remove the hydrostatic transmission assembly (1) from transmission case.

(When reassembling)

- Apply oil to the O-rings and take care not to damage them.
- Apply liquid lock (Three Bond 1324 or its equivalent) to the thread of hydrostatic transmission mounting screws.

Tightening torque	Hydrostatic transmission mounting screw	15.7 to 20.6 N·m 1.6 to 2.1 kgf·m 11.6 to 15.2 ft-lbs
-------------------	---	---

- (1) Hydrostatic Transmission Assembly

W1017437

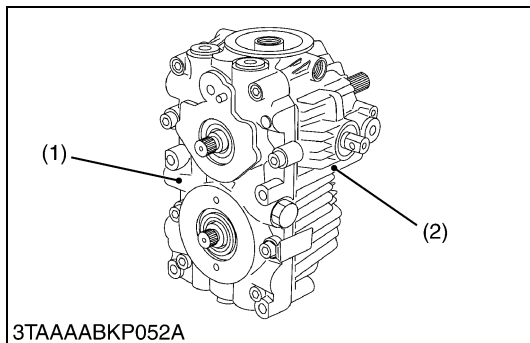

Center Section

1. Remove the center section mounting hex. socket head screws.
2. Tap the center section (1) with soft hammer and separate the center section (1) from the HST housing (2).

(When reassembling)

- Cover the splines of each shaft with thin tape to protect the sealing lip of the oil seals.
- Place a new gasket on the HST housing.

NOTE

- **Take care not to damage the surface of cylinder blocks, pistons and center section.**

Tightening torque	Center section mounting hex. socket head screw	39.2 to 44.1 N·m 4.0 to 4.5 kgf·m 28.9 to 32.5 ft-lbs
-------------------	--	---

- (1) Center Section (2) HST Housing

W1022048

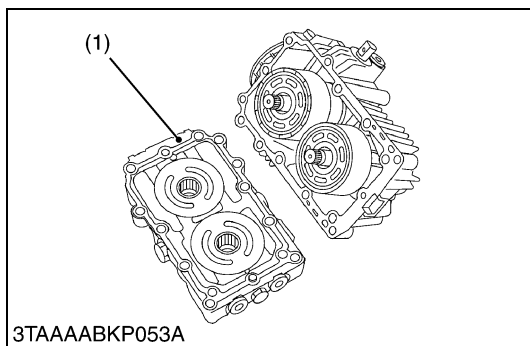

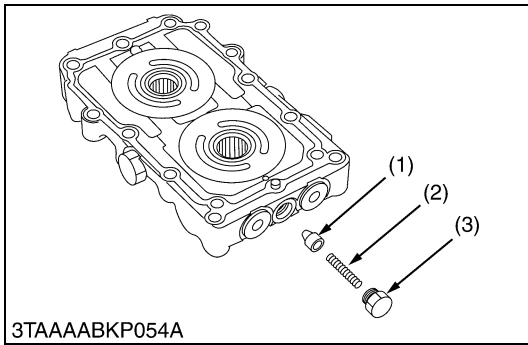

Charge Relief Valve

1. Remove the plug (3) and draw out the spring (2) and charge relief cone (1).

(When reassembling)

- Take care not to damage the O-ring on the plug.

NOTE

- **If the shims are placed at the bottom of the relief valve plug bore, place them as they are.**

Tightening torque	Charge relief valve plug	14.22 to 23.54 N·m 1.45 to 2.40 kgf·m 10.49 to 17.36 ft·lbs
-------------------	--------------------------	---

- (1) Charge Relief Cone (3) Plug
(2) Spring

W1022241

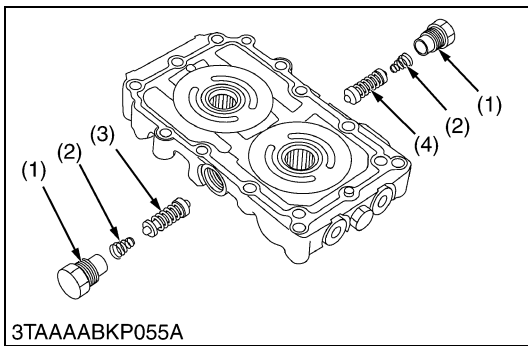

Check and High Pressure Relief Valve

1. Remove the plug (1) and draw out the spring (2) and check and high pressure relief valve assembly (3), (4).

(When reassembling)

- Take care not to damage the O-ring on the plug.

Tightening torque	Check and high pressure relief valve plug	40.70 to 94.93 N·m 4.15 to 9.68 kgf·m 30.02 to 70.02 ft·lbs
-------------------	---	---

- (1) Plug (4) Check and High Pressure Relief Valve Assembly (Reverse)
(2) Spring
(3) Check and High Pressure Relief Valve Assembly (Forward)

W1022380

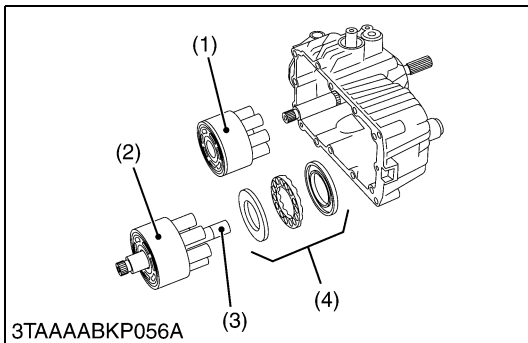

Cylinder Block Assembly and Thrust Ball Bearing

1. Remove the cylinder block assembly (pump side) (1).
2. Remove the cylinder block assembly (motor side) (2) with the motor shaft (3).
3. Remove the thrust ball bearing (4).

(When reassembling)

- Apply clean transmission oil to thrust ball bearing, cylinder block and piston.

NOTE

- **Take care not to damage the surface of cylinder blocks and pistons.**

- (1) Cylinder Block Assembly (Pump Side) (3) Motor Shaft
(2) Cylinder Block Assembly (Motor Side) (4) Thrust Ball Bearing

W1022614

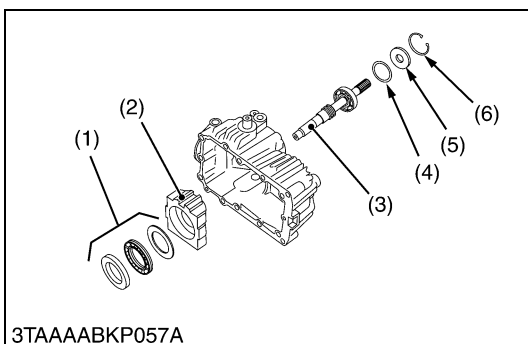

Swashplate and Pump Shaft

1. Remove the swashplate (2) and thrust roller bearing (1) from the HST housing.
2. Remove the internal snap ring (6) and tap out the pump shaft (3), spacer (4) and oil seal (5).

(When reassembling)

- Apply clean transmission oil to the thrust roller bearing.

- (1) Thrust Roller Bearing (4) Spacer
(2) Swashplate (5) Oil Seal
(3) Pump Shaft (6) Internal Snap Ring

W1022771

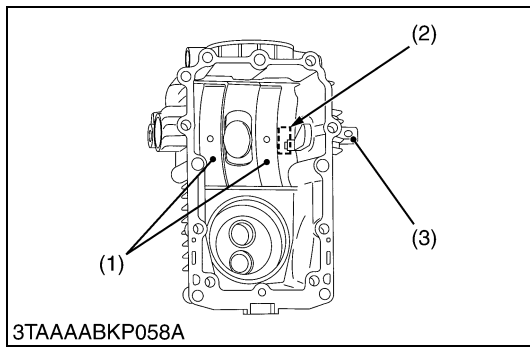

Cradle Bearing, Slot Guide and Trunnion Arm

1. Remove the slot guide (2) and trunnion arm (3).
2. Remove the cradle bearing (1) from the HST housing.

(When reassembling)

- Apply clean transmission oil to the cradle bearing and trunnion arm.
- Fasten down the cradle bearing to the HST housing.

- (1) Cradle Bearing (3) Trunnion Arm
 (2) Slot Guide

W1022902

[3] TRANSMISSION CASE

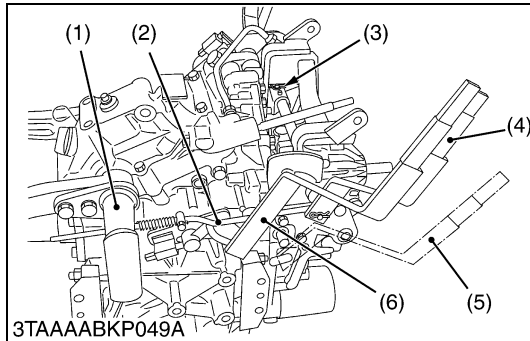

Levers and Mower Lift Arm

1. Tap out the spring pin from the range gear shift lever (6) and front wheel drive lever (5), then remove the both levers.
2. Remove the mower lift arm (1) with feedback rod (2).
3. Remove the rue ring (3) and hydraulic control lever mounting bolt and nut, then remove the hydraulic control lever (4).

(When reassembling)

Tightening torque	Hydraulic control lever mounting bolt and nut	17.7 to 20.6 N·m 1.8 to 2.1 kgf·m 13.0 to 15.2 ft·lbs
-------------------	---	---

- (1) Mower Lift Arm (4) Hydraulic Control Lever
 (2) Feedback Rod (5) Front Wheel Drive Lever
 (3) Rue Ring (6) Range Gear Shift Lever

W1023064

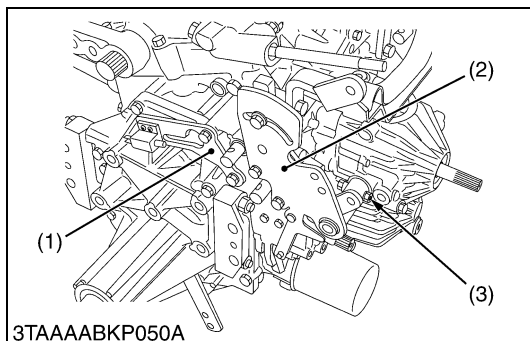

Neutral Plate and Neutral Switch Stay

1. Remove the trunnion arm mounting bolt and nut (3).
2. Remove the neutral plate mounting screws, then remove the neutral plate (2).
3. Remove the neutral switch stay (1).

(When reassembling)

Tightening torque	Trunnion arm mounting bolt and nut	9.8 to 11.3 N·m 1.00 to 1.15 kgf·m 7.2 to 8.3 ft·lbs
-------------------	------------------------------------	--

- (1) Neutral Switch Stay (3) Trunnion Arm Mounting Bolt and Nut
 (2) Neutral Plate

W1023204

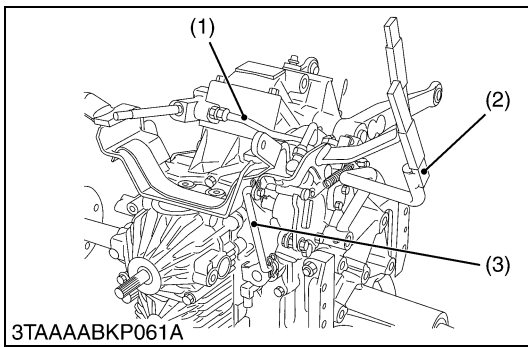

PTO Select Lever and Control Valve

1. Remove the delivery pipe (1) and PTO clutch rod (3).
2. Tap out the spring pin and remove the PTO select lever (2).
3. Remove the control valve (5) with PTO safety switch stay (4).

(When reassembling)

- Apply oil to the O-rings and take care not to damage them.

Tightening torque	Delivery pipe	28.4 to 30.0 N-m 2.9 to 3.1 kgf-m 20.9 to 22.1 ft-lbs
	PTO safety switch mounting screw (with control valve)	17.7 to 20.6 N-m 1.8 to 2.1 kgf-m 13.0 to 15.2 ft-lbs

- | | |
|----------------------|----------------------------|
| (1) Delivery Pipe | (4) PTO Safety Switch Stay |
| (2) PTO Select Lever | (5) Control Valve |
| (3) PTO Clutch Rod | |

W1023043

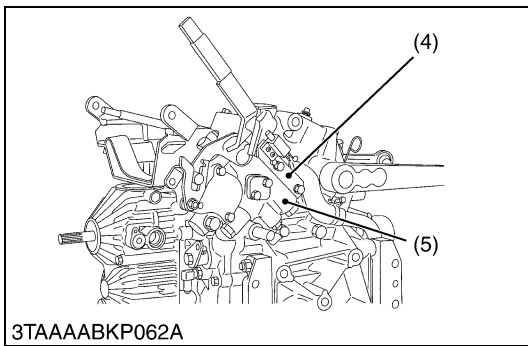

Hydraulic Pump and Suction Pipe

1. Remove the hydraulic pump (1) and suction pipe (3) from the transmission case.

(When reassembling)

- Do not twist the suction hose (2).
- Take care not to damage the O-rings.

- | | |
|--------------------|------------------|
| (1) Hydraulic Pump | (3) Suction Pipe |
| (2) Suction Hose | |

W1023493

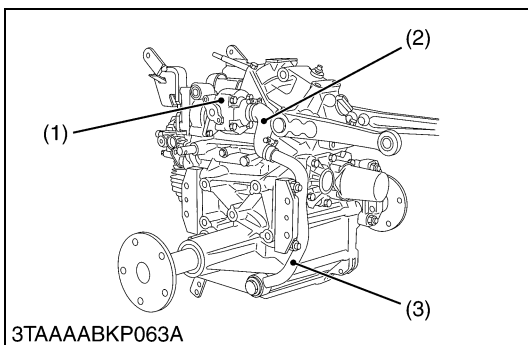

Seat Rail Front Stay and Hydrostatic Transmission Assembly

1. Remove the seat rail front stay (1).
2. Remove the hydrostatic transmission assembly (2) and oil filter cartridge (3).

(When reassembling)

- Apply oil to the O-rings and take care not to damage them.
- Apply liquid lock (Three Bond 1324 or equivalent) to the thread of hydrostatic transmission mounting screws.

Tightening torque	Hydrostatic transmission mounting screw	15.7 to 20.6 N-m 1.6 to 2.1 kgf-m 11.6 to 15.2 ft-lbs
-------------------	---	---

- | | |
|---------------------------------------|--------------------------|
| (1) Seat Rail Front Stay | (3) Oil Filter Cartridge |
| (2) Hydrostatic Transmission Assembly | |

W1023679

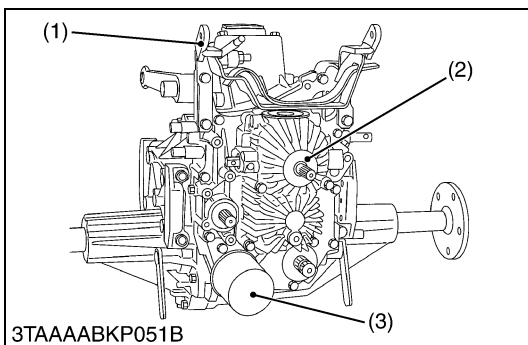

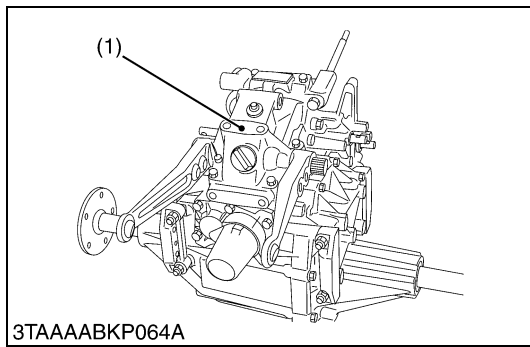

Hydraulic Cylinder

1. Remove the hydraulic cylinder mounting screws and dismount the hydraulic cylinder (1).

(When reassembling)

- Apply liquid gasket (Three Bond 1208D or equivalent) to joint face of the transmission case to hydraulic cylinder.

Tightening torque	Hydraulic cylinder mounting screw	39.2 to 44.1 N·m 4.0 to 4.5 kgf·m 28.9 to 32.5 ft·lbs
-------------------	-----------------------------------	---

(1) Hydraulic Cylinder

W1023836

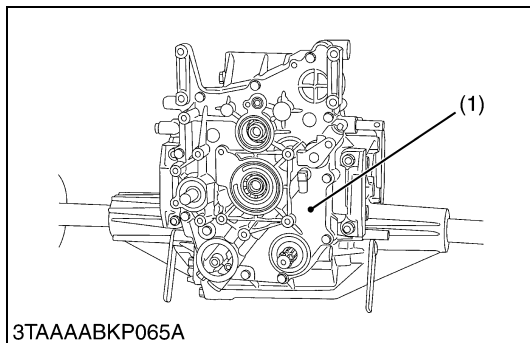

Front Cover

1. Remove the front cover mounting screws and separate the front cover (1).

(When reassembling)

- Apply liquid gasket (Three Bond 1208D or equivalent) to joint face of the transmission case to front cover.
- The spring pin on the front wheel drive idle shaft and gear pump idle shaft should face upper side.
- Apply grease to the collar on the front wheel drive shaft.
- Take care not to damage the O-ring.

Tightening torque	Front cover mounting screw	39.2 to 44.1 N·m 4.0 to 4.5 kgf·m 28.9 to 32.5 ft·lbs
-------------------	----------------------------	---

(1) Front Cover

W1023957

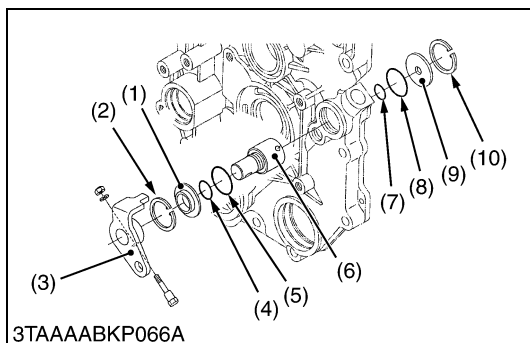

PTO Clutch Valve

1. Remove the PTO clutch arm (3).
2. Remove the internal snap ring (10), then draw out the PTO clutch collar (9) and PTO clutch valve (6).
3. Remove the internal snap ring (2) and draw out the PTO clutch sleeve (1).

(When reassembling)

- Take care not to damage the O-rings.

Tightening torque	PTO clutch arm mounting bolt and nut	9.8 to 14.7 N·m 1.00 to 1.15 kgf·m 7.2 to 10.8 ft·lbs
-------------------	--------------------------------------	---

- | | |
|------------------------|-------------------------|
| (1) PTO Clutch Sleeve | (6) PTO Clutch Valve |
| (2) Internal Snap Ring | (7) O-ring |
| (3) PTO Clutch Arm | (8) O-ring |
| (4) O-ring | (9) PTO Clutch Collar |
| (5) O-ring | (10) Internal Snap Ring |

W1024111

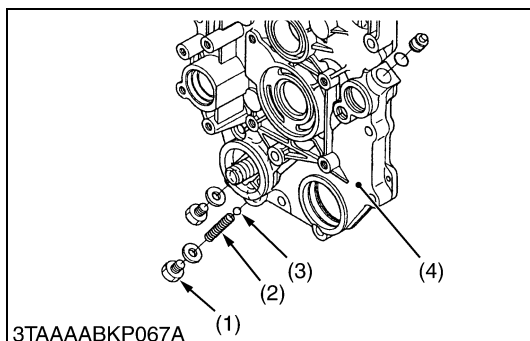

PTO Relief Valve

1. Remove the PTO relief valve plug (1), then draw out the spring (2) and steel ball (3).

(When reassembling)

Tightening torque	PTO relief valve plug	21.58 to 25.50 N·m 2.2 to 2.6 kgf·m 15.91 to 18.81 ft·lbs
-------------------	-----------------------	---

- | | |
|---------------------------|-----------------|
| (1) PTO Relief Valve Plug | (3) Steel Ball |
| (2) Spring | (4) Front Cover |

W1024483

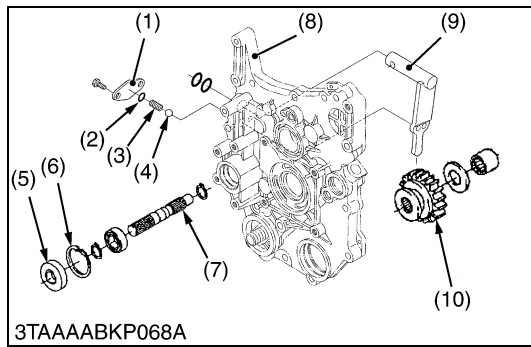

Front Wheel Drive Shaft and Shift Fork

1. Remove the plate (1), then draw out the spring (3) and steel ball (4).
2. Remove the oil seal (5) and internal snap ring (6).
3. Tap out the front wheel drive shaft (7) to the front.
4. Remove the 19T shifter gear (10) and front wheel drive shift fork (9).

(When reassembling)

- Take care not to damage the O-ring.
- Replace the oil seal (5) with new one.

- | | |
|----------------|----------------------------------|
| (1) Plate | (6) Internal Snap Ring |
| (2) O-ring | (7) Front Wheel Drive Shaft |
| (3) Spring | (8) Front Cover |
| (4) Steel Ball | (9) Front Wheel Drive Shift Fork |
| (5) Oil Seal | (10) 19T Shifter Gear |

W1024622

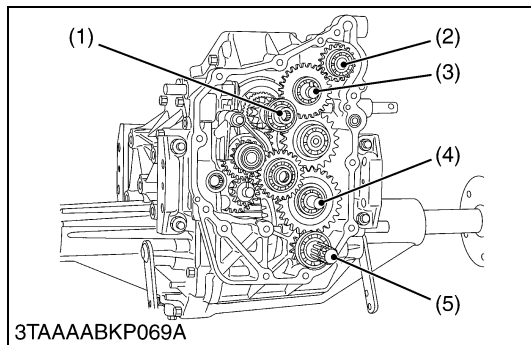

13T Gear, 19T Gear Shaft, Hydraulic Pump Idle Shaft, Mid-PTO Shaft and Mid-PTO Idle Shaft

1. Remove the 13T gear assembly (1), 19T gear shaft assembly (2) and hydraulic pump idle shaft assembly (3).
2. Remove the mid-PTO shaft assembly (5) and mid-PTO idle shaft assembly (4).

- | | |
|--|---------------------------------|
| (1) 13T Gear Assembly | (4) Mid-PTO Idle Shaft Assembly |
| (2) 19T Gear Shaft Assembly | (5) Mid-PTO Shaft Assembly |
| (3) Hydraulic Pump Idle Shaft Assembly | |

W1024846

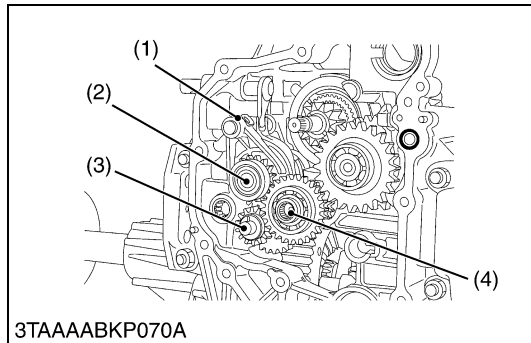

Spiral Bevel Gear Shaft, 17T-25T Gear Shaft and Front Wheel Drive Idle Shaft

1. Remove the front wheel drive idle shaft assembly (3) and 17T-25T gear shaft assembly (4).
2. Remove the spiral bevel gear shaft assembly (2) together with range gear shift fork (1).

(When reassembling)

- Install all of the above mentioned parts, simultaneously.

- | | |
|--------------------------------------|---|
| (1) Range Gear Shift Fork | (3) Front Wheel Drive Idle Shaft Assembly |
| (2) Spiral Bevel Gear Shaft Assembly | (4) 17T-25T Gear Shaft Assembly |

W1024950

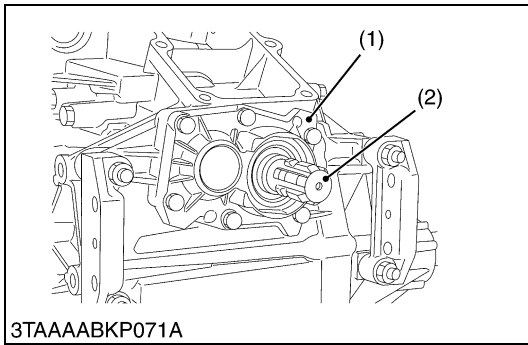

Rear Cover, Rear PTO Shaft and Rear PTO Drive Shaft

1. Remove the rear cover (1) and rear PTO shaft assembly (2).
2. Remove the PTO select bolt (3) and draw out the spring and steel ball.
3. Remove the rear PTO drive shaft assembly (4).

(When reassembling)

- Apply liquid gasket (Three Bond 1208D or equivalent) to joint face of the transmission case to rear cover.
- Apply grease to the lip of oil seal.

Tightening torque	Rear cover mounting screw	39.2 to 44.1 N·m 4.0 to 4.5 kgf·m 28.9 to 32.5 ft-lbs
	PTO select bolt	21.6 to 25.5 N·m 2.2 to 2.6 kgf·m 15.9 to 18.8 ft-lbs

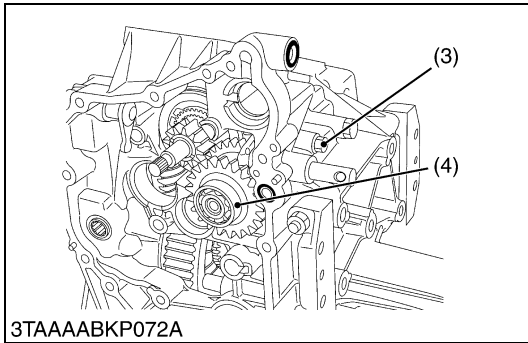

- (1) Rear Cover
- (2) Rear PTO Shaft Assembly
- (3) PTO Select Bolt
- (4) Rear PTO Drive Shaft Assembly

W1025166

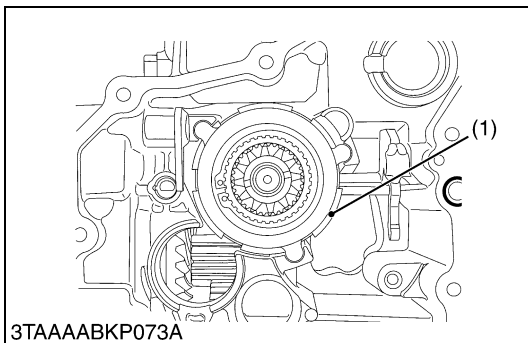

PTO Clutch Assembly

1. Remove the PTO clutch assembly (1) from transmission case.

(When reassembling)

- Apply transmission oil to the seal ring on the clutch shaft.

- (1) PTO Clutch Assembly

W1025392

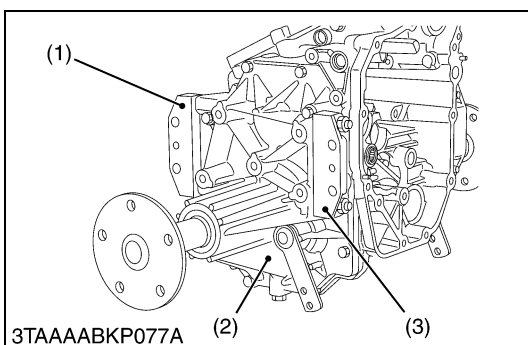
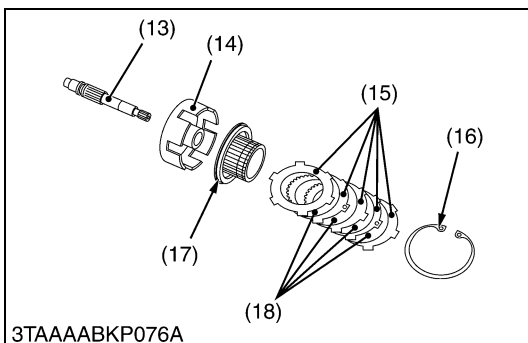
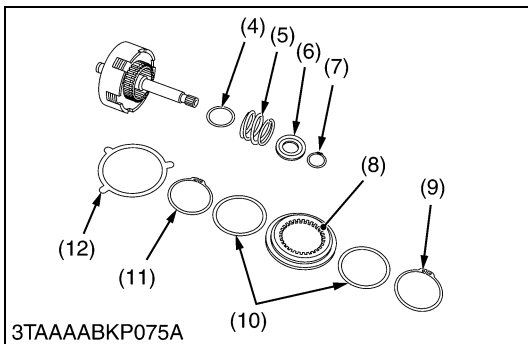
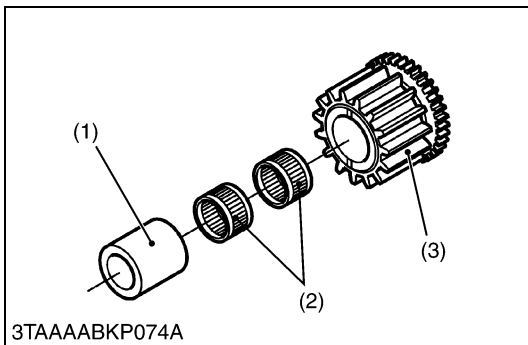

Disassembling PTO Clutch Assembly

1. Remove the collar (1), needle bearings (2) and 12T gear clutch (3).
2. Remove the external snap ring (9), then remove the shims (10), brake pressure plate (8) and brake disc (12).
3. Remove the external snap rings (11) and (7).
4. Remove the spring collar (6), clutch spring (5) and bearing collar (4).
5. Remove the internal snap ring (16), then draw out the pressure plates (15) and clutch discs (18).
6. Tap out the clutch shaft (13) and remove the clutch piston (17) from clutch case (14).

(When reassembling)

- Apply transmission oil to the O-rings, D-ring and seal ring, and take care not to damage it.

- | | |
|--------------------------|-------------------------|
| (1) Collar | (10) Shim |
| (2) Needle Bearing | (11) External Snap Ring |
| (3) 12T Gear Clutch | (12) Brake Disc |
| (4) Bearing Collar | (13) Clutch Shaft |
| (5) Clutch Spring | (14) Clutch Case |
| (6) Spring Collar | (15) Pressure Plate |
| (7) External Snap Ring | (16) Internal Snap Ring |
| (8) Brake Pressure Plate | (17) Clutch Piston |
| (9) External Snap Ring | (18) Clutch Disc |

W1025482

Axle Cover

1. Remove the rear bracket (1) and front bracket (3).
2. Remove the axle cover (2) from transmission case.

(When reassembling)

- Apply liquid gasket (Three Bond 1208D or equivalent) to joint face of the transmission case to axle cover.
- Align the mounting surface of the front bracket, rear bracket and axle cover to the transmission case before tightening the bracket mounting nut.

Tightening torque	Bracket mounting nut	77.5 to 90.1 N-m 7.9 to 9.2 kgf-m 57.2 to 66.5 ft-lbs
	Axle cover mounting screw	39.2 to 44.1 N-m 4.0 to 4.5 kgf-m 28.9 to 32.5 ft-lbs

- | | |
|------------------|-------------------|
| (1) Rear Bracket | (3) Front Bracket |
| (2) Axle Cover | |

W1026073

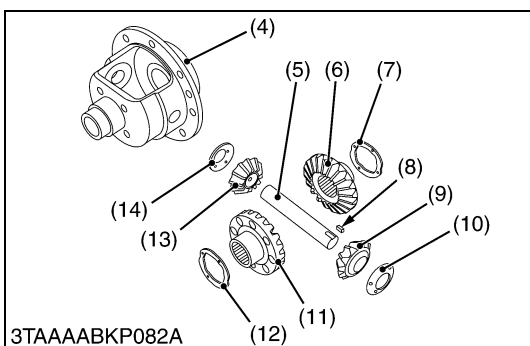
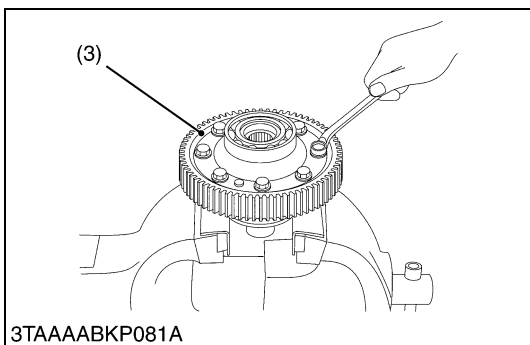
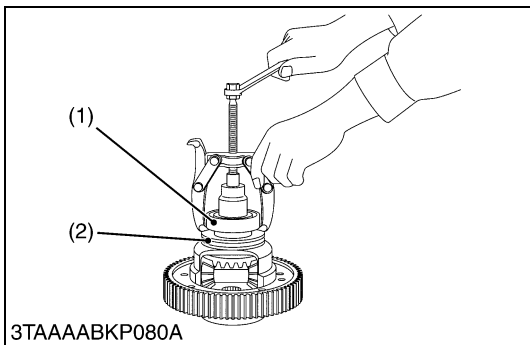
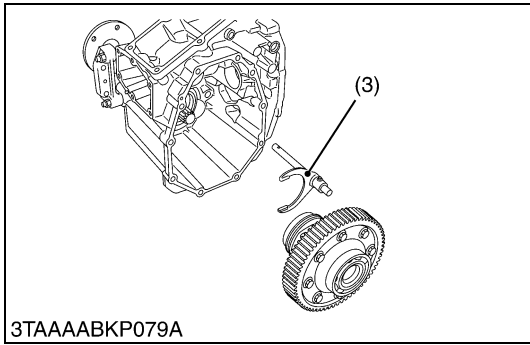
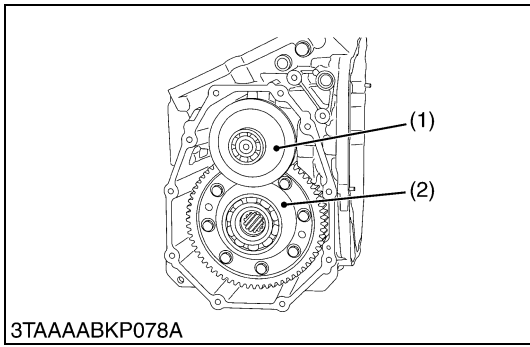

Final Gear Shaft and Differential Gear Assembly

1. Draw out the final gear shaft assembly (1), differential gear assembly (2) and differential lock shift fork (3).

(When reassembling)

- Take care not to damage the O-ring.

- (1) Final Gear Shaft Assembly
- (2) Differential Gear Assembly
- (3) Differential Lock Shift Fork

W1026307

Disassembling Differential Gear Assembly

1. Remove the bearing (1), differential lock shifter (2) and 66T final gear (3).
2. Put parting marks on the differential pinions (9), (13) and the differential side gears (6), (11).
3. Tap out the differential pinion shaft (5).
4. Remove the differential pinions (9), (13), differential pinion washers (10), (14), differential side gears (6), (11) and differential side gear washers (7), (12).

(When reassembling)

- Install the differential pinion and differential side gear, aligning the parting marks.
- Lock the differential pinion shaft (5) by setting the key (8).

Tightening torque	66T final gear mounting screw	60.8 to 70.6 N·m 6.2 to 7.2 kgf·m 44.8 to 52.1 ft·lbs
-------------------	-------------------------------	---

- (1) Bearing
- (2) Differential Lock Shifter
- (3) 66T Final Gear
- (4) Differential Case
- (5) Differential Pinion Shaft
- (6) Differential Side Gear
- (7) Differential Side Gear Washer
- (8) Key
- (9) Differential Pinion
- (10) Differential Pinion Washer
- (11) Differential Side Gear
- (12) Differential Side Gear Washer
- (13) Differential Pinion
- (14) Differential Pinion Washer

W1026489

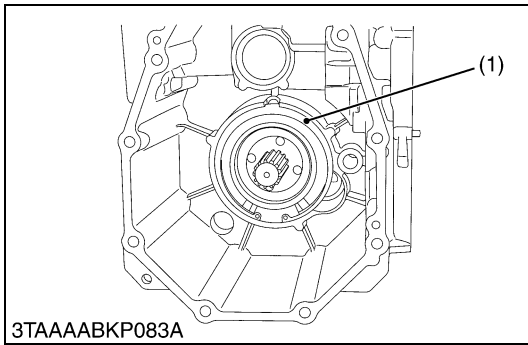

Brake Disc and Friction Plate

1. Remove the internal snap ring (1).
2. Remove the bearing holder (6), brake discs (5), friction plates (2), actuator (3) and steel balls (4).
3. Remove the external snap ring (8), then remove the cam lever (7).

(When reassembling)

- Apply grease to the steel balls.
- Install the brake discs with their holes deviation at less than 1/3 of the total hole area.
- When installing the bearing holder, do not forget to install the straight pin.
- Install the internal snap ring (1) as shown in the figure. (Open end of the snap ring should place bottom side.)
- Take care not to damage the O-ring.

- | | |
|------------------------|------------------------|
| (1) Internal Snap Ring | (5) Brake Disc |
| (2) Friction Plate | (6) Bearing Holder |
| (3) Actuator | (7) Cam Lever |
| (4) Steel Ball | (8) External Snap Ring |

W1026785

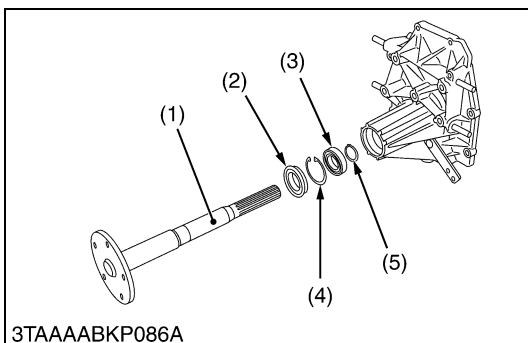
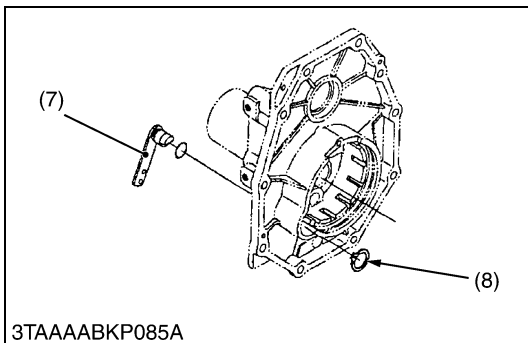
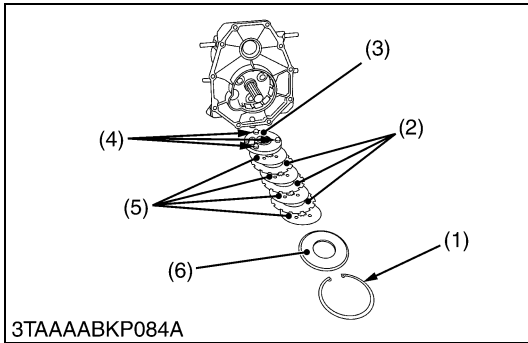

Rear Axle

1. Remove the oil seal (2), then remove the internal snap ring (4).
2. Tap out the rear axle (1) from transmission case or rear axle cover.

(When reassembling)

- Do not apply oil to the outer circumference of the oil seal.

- | | |
|---------------|------------------------|
| (1) Rear Axle | (4) Internal Snap Ring |
| (2) Oil Seal | (5) External Snap Ring |
| (3) Bearing | |

W1027164

6. SERVICING

[1] HYDROSTATIC TRANSMISSION

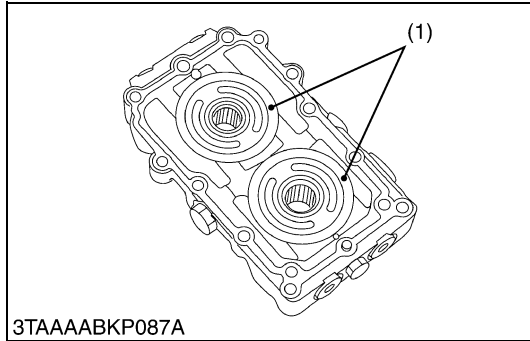

Center Section

1. Check the surface (1) of center section for scratches or wear. If deep scratch or excessive wear is found, replace the hydrostatic transmission assembly.

(1) Surface

W1027317

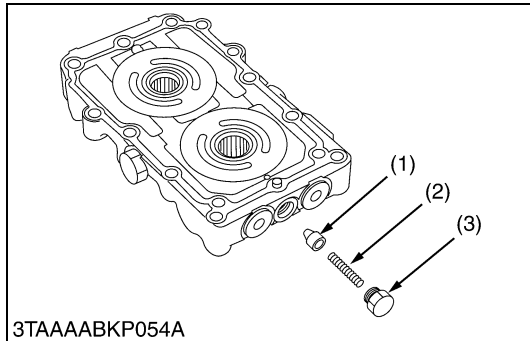

Charge Relief Valve

1. Check the charge relief cone (1) and spring (2).
2. If defects are found, replace them.

(1) Charge Relief Cone

(3) Plug

(2) Spring

W1027386

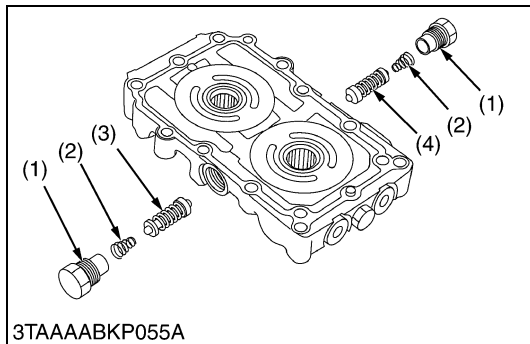

Check and High Pressure Relief Valve

1. Check the valves (3), (4) for scratches and damage.
2. Check the spring (2) for breakage and wear.
3. If anything unusual, replace the check and high pressure relief valve complete assembly.

(1) Plug

(4) Check and High Pressure Relief Valve

(2) Spring

(3) Check and High Pressure Relief Valve

W1027478

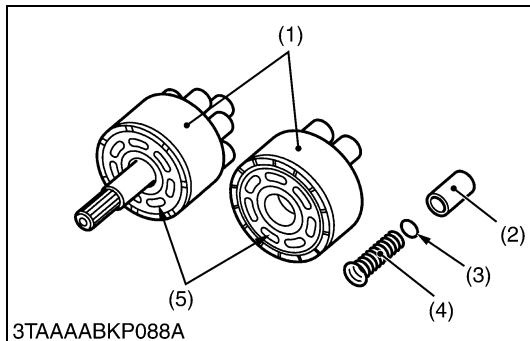

Cylinder Block Assembly

1. Check the cylinder blocks (1) and pistons (2) for scratches and wear.
2. If scratch or worn, replace the cylinder block assembly.
3. Check that the piston (2), spring (4) and thrust washer (3) are in each cylinder bore.
4. Check the pistons for their free movement in the cylinder block bores.
5. If the piston or the cylinder block is scored, replace the cylinder block assembly.
6. Check the polished face (5) of cylinder block for scoring.
7. If scored, replace the cylinder block assembly.

■ IMPORTANT

- Do not interchange pistons between pump and motor cylinder block. Pistons and cylinder blocks are matched.

(1) Cylinder Block

(4) Spring

(2) Piston

(5) Polished Face

(3) Thrust Washer

W1027589

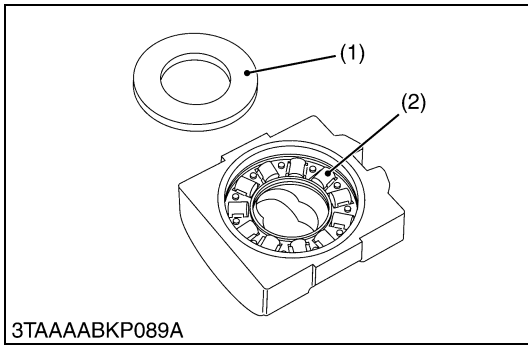

Thrust Washer, Thrust Roller Bearing and Thrust Plate

1. Check the thrust roller bearing (2) for scratches and excessive wear.
2. If worn, replace.
3. Check the thrust plate (1) for scratches and excessive wear.
4. If worn or scored, replace.

(1) Thrust Plate (2) Thrust Roller Bearing

W1027775

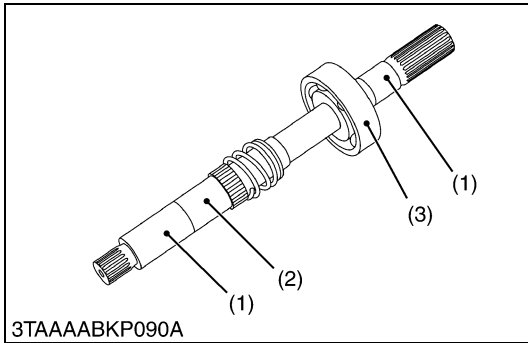

Pump Shaft

1. Check the seal surface (1), the bearing surface (2) and the ball bearing (3).
2. If the shaft is rough or grooved, replace it.
3. If the ball bearing is worn, replace it.

(1) Seal Surface (2) Bearing Surface (3) Ball Bearing

W1027972

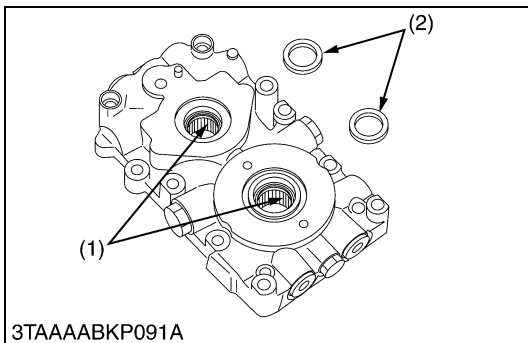

Needle Bearing and Oil Seal

1. Check the oil seals (2) for damage.
2. Check the needle bearings (1) for wear.
3. If the oil seals and needle bearings are worn or damaged, replace them.

(1) Needle Bearing (2) Oil Seal

W1028196

[2] TRANSMISSION CASE

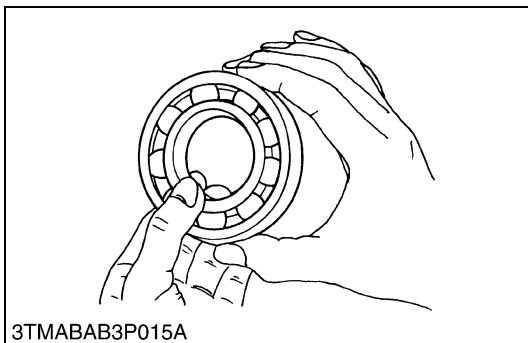

Checking Bearing

1. Hold the inner race, and push and pull the outer race in all directions to check for wear and roughness.
2. Apply transmission fluid to the bearing, and hold the inner race. Then, turn the outer race to check rotation.
3. If there is any defect, replace it.

W10260490

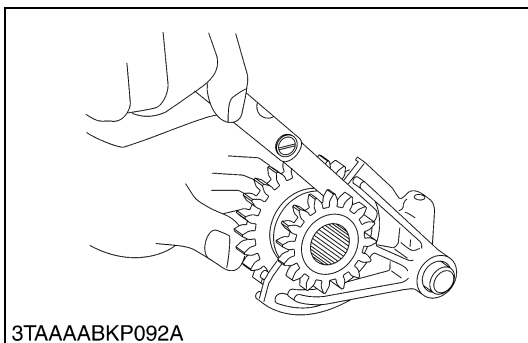

Clearance between Shift Fork and Shifter Gear Groove (Range Gear Shift)

1. Insert the shift fork into the shifter gear groove and measure the clearance with a feeler gauge.
2. If the clearance exceeds the allowable limit, replace it.

Clearance between shift fork and shifter gear groove	Factory spec.	0.03 to 0.48 mm 0.0012 to 0.019 in.
	Allowable limit	0.7 mm 0.028 in.

W1028380

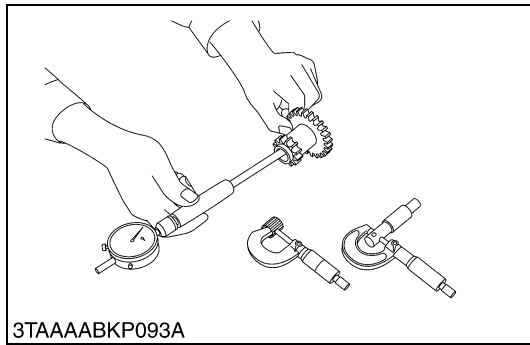

3TAAAABKP093A

Clearance between 13T-25T Gear and Front Wheel Drive Idle Shaft

1. Measure the 13T-25T gear I.D. with a cylinder gauge, and then front wheel drive idle shaft O.D. with an outside micrometer.
2. Measure the O.D. of two needles in the needle bearing with an outside micrometer.
3. Clearance is the difference between the gear I.D. and the sum of shaft O.D. and two needle O.D..
4. If the clearance exceeds the allowable limit, replace it.

Clearance between 13T-25T gear and front wheel drive idle shaft	Factory spec.	0.007 to 0.043 mm 0.0003 to 0.0017 in.
	Allowable limit	0.10 mm 0.0039 in.

13T-25T gear I.D.	Factory spec.	19.007 to 19.020 mm 0.7483 to 0.7488 in.
Front wheel drive idle shaft O.D.	Factory spec.	13.989 to 14.000 mm 0.5507 to 0.5512 in.
Needle O.D.	Factory spec.	2.494 to 2.500 mm 0.0982 to 0.0984 in.

W1028475

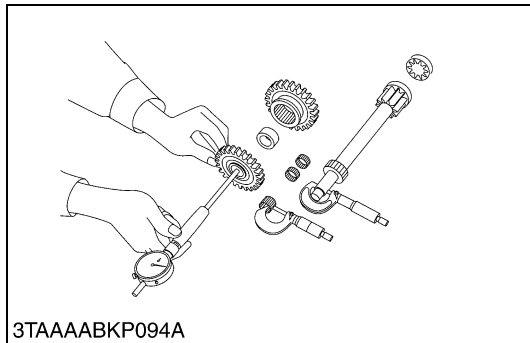

3TAAAABKP094A

Clearance between 22T Gear and 11T Gear Shaft

1. Measure the 22T gear I.D. with a cylinder gauge, and then 11T gear shaft O.D. with an outside micrometer.
2. Measure the O.D. of two needles in the needle bearing with an outside micrometer.
3. Clearance is the difference between the gear I.D. and the sum of shaft O.D. and two needle O.D..
4. If the clearance exceeds the allowable limit, replace it.

Clearance between 22T gear and 11T gear shaft	Factory spec.	0.007 to 0.039 mm 0.0003 to 0.0015 in.
	Allowable limit	0.10 mm 0.0039 in.

22T gear I.D.	Factory spec.	24.007 to 24.020 mm 0.9452 to 0.9457 in.
11T gear shaft O.D.	Factory spec.	19.987 to 20.000 mm 0.7869 to 0.7874 in.
Needle O.D.	Factory spec.	1.997 to 2.000 mm 0.0786 to 0.0787 in.

W1028725

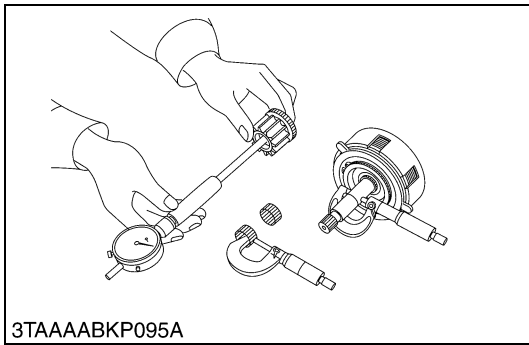

Clearance between 12T Gear Clutch and Clutch Shaft

1. Measure the 12T gear clutch I.D. with a cylinder gauge, and then clutch shaft O.D. with an outside micrometer.
2. Measure the O.D. of two needles in the needle bearing with an outside micrometer.
3. Clearance is the difference between the gear clutch I.D. and the sum of shaft O.D. and two needle O.D..
4. If the clearance exceeds the allowable limit, replace it.

Clearance between 12T gear clutch and clutch shaft	Factory spec.	0.007 to 0.037 mm 0.0003 to 0.0015 in.
	Allowable limit	0.10 mm 0.0039 in.

12T gear clutch I.D.	Factory spec.	22.007 to 22.020 mm 0.8664 to 0.8669 in.
Clutch shaft O.D.	Factory spec.	17.989 to 18.000 mm 0.7082 to 0.7087 in.
Needle O.D.	Factory spec.	1.997 to 2.000 mm 0.0786 to 0.0787 in.

W1028898

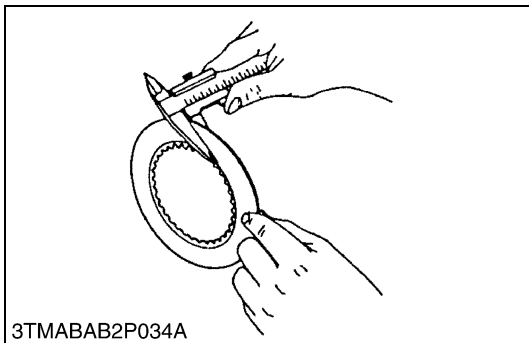

PTO Clutch Disc Wear

1. Measure the thickness of PTO clutch disc with vernier calipers.
2. If the thickness is less than the allowable limit, replace it.

Thickness of PTO clutch disc	Factory spec.	1.70 to 1.90 mm 0.067 to 0.075 in.
	Allowable limit	1.55 mm 0.061 in.

W1024320

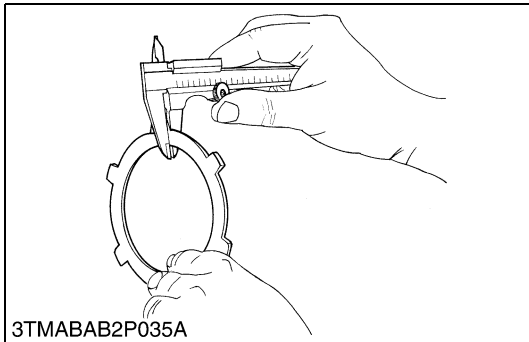

Pressure Plate and Steel Plate Wear

1. Measure the thickness of pressure plate and steel plate with vernier calipers.
2. If the thickness is less than the allowable limit, replace it.

Thickness of pressure plate	Factory spec.	1.95 to 2.05 mm 0.077 to 0.081 in.
	Allowable limit	1.80 mm 0.071 in.

Thickness of steel plate	Factory spec.	1.15 to 1.25 mm 0.045 to 0.049 in.
	Allowable limit	1.10 mm 0.043 in.

W1017226

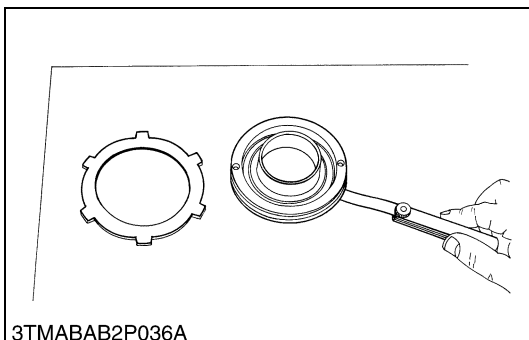

Flatness of Clutch Piston, Pressure Plate and Steel Plate

1. Place the part on a surface plate.
2. Check the flatness by inserting a feeler gauge (allowable limit size) underneath it at least four points.
3. If the gauge can be inserted, replace it.

Flatness of clutch piston	Allowable limit	0.15 mm 0.0059 in.
---------------------------	-----------------	-----------------------

Flatness of pressure plate and steel plate	Allowable limit	0.20 mm 0.0079 in.
--	-----------------	-----------------------

W1017358

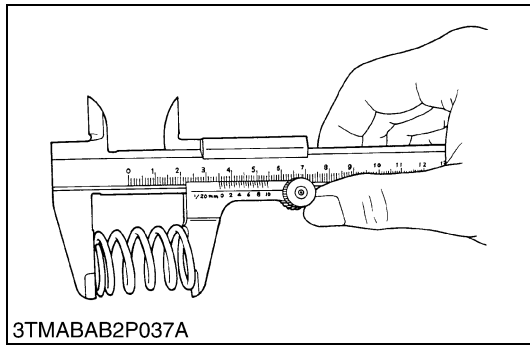

3TMABAB2P037A

Clutch Spring Free Length

1. Measure the free length of spring with vernier calipers.
2. If the measurement is less than the allowable limit, replace it.

Clutch spring free length	Factory spec.	37.3 to 37.7 mm 1.47 to 1.48 in.
	Allowable limit	34.5 mm 1.36 in.

W1017533

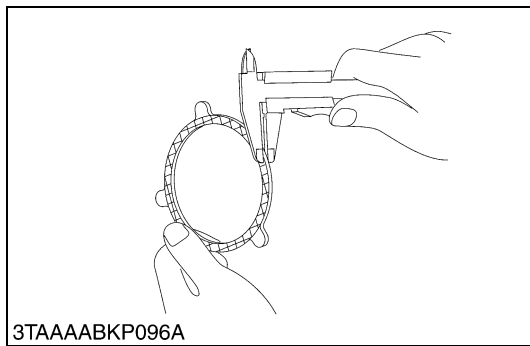

3TAAAABKP096A

PTO Brake Disc Wear

1. Measure the PTO brake disc thickness with a vernier caliper.
2. If the thickness is less than allowable limit, replace it.

PTO brake disc thickness	Factory spec.	3.20 to 3.40 mm 0.126 to 0.134 in.
	Allowable limit	3.00 mm 0.118 in.

W1029590

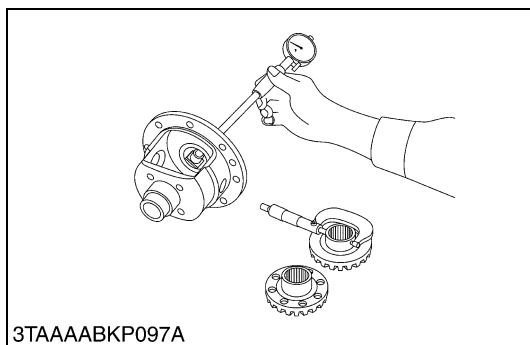

3TAAAABKP097A

Clearance between Differential Case and Differential Side Gear

1. Measure the differential side gear boss O.D. with an outside micrometer.
2. Measure the differential case I.D. with a cylinder gauge and calculate the clearance.
3. If the clearance exceeds the allowable limit, replace faulty parts.

Clearance between differential case and differential side gear	Factory spec.	0.050 to 0.151 mm 0.0020 to 0.0059 in.
	Allowable limit	0.30 mm 0.0118 in.

Differential case I.D.	Factory spec.	38.000 to 38.062 mm 1.4961 to 1.4985 in.
Differential side gear O.D.	Factory spec.	37.911 to 37.950 mm 1.4926 to 1.4941 in.

W1029693

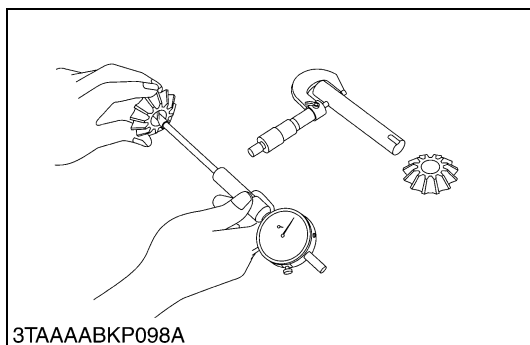

3TAAAABKP098A

Clearance between Differential Pinion Shaft and Differential Pinion

1. Measure the differential pinion shaft O.D. with an outside micrometer.
2. Measure the differential pinion I.D. with a cylinder gauge, and calculate the clearance.
3. If the clearance exceeds the allowable limit, replace faulty parts.

Clearance between differential pinion shaft and differential pinion	Factory spec.	0.080 to 0.122 mm 0.0031 to 0.0048 in.
	Allowable limit	0.30 mm 0.0118 in.

Differential pinion I.D.	Factory spec.	20.060 to 20.081 mm 0.7898 to 0.7906 in.
Differential pinion shaft O.D.	Factory spec.	19.959 to 19.980 mm 0.7858 to 0.7866 in.

W1029832

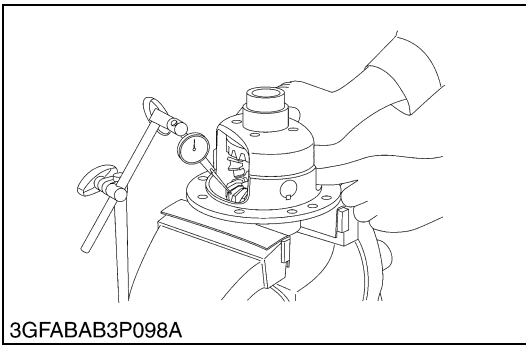

3GFABAB3P098A

Backlash between Differential Pinion and Differential Side Gear

1. Secure the differential case with a vise.
2. Set the dial indicator (lever type) with its finger on the tooth of the differential side gear.
3. Press differential pinion and side gear against the differential case.
4. Hold the differential pinion and move the differential side gear to measure the backlash.
5. If the backlash exceeds the allowable limit, adjust with differential side gear shims.

Backlash between differential pinion and differential side gear	Factory spec.	0.15 to 0.30 mm 0.0059 to 0.0118 in.
	Allowable limit	0.40 mm 0.0157 in.

(Reference)

- Thickness of shims :
1.5 mm (0.0591 in.), 1.6 mm (0.0630 in.), 1.7 mm (0.0669 in.)

W1029971

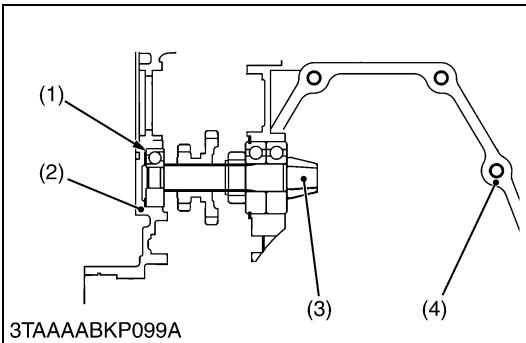

3TAAAABKP099A

Side Clearance of Spiral Bevel Pinion Shaft

1. Temporary assemble the spiral bevel pinion shaft (3) and front cover (2) to the transmission case (4).
2. Set the dial indicator (lever type) with its finger on the end of spiral bevel pinion shaft (3).
3. Move the spiral bevel pinion shaft (3) back and forth to each end and measure the side clearance.
4. If the side clearance exceeds the factory specifications, adjust with the shim (1) at front end of spiral bevel pinion shaft (3).

Side clearance of spiral bevel pinion shaft	Factory spec.	0.1 to 0.3 mm 0.0039 to 0.0118 in.
---	---------------	---------------------------------------

(Reference)

- Thickness of shims :
0.2 mm (0.0079 in.), 0.5 mm (0.0197 in.)

- (1) Shim
- (2) Front Cover
- (3) Spiral Bevel Pinion Shaft
- (4) Transmission Case

W1030223

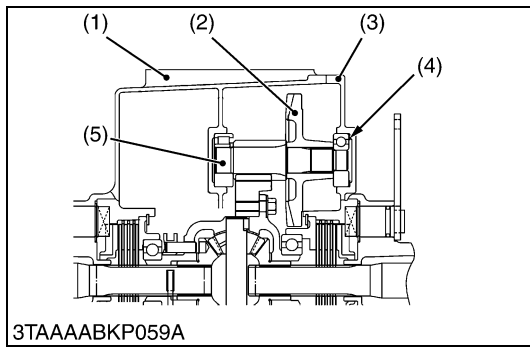

3TAAAABKP059A

Backlash between Spiral Bevel Pinion Shaft and Spiral Bevel Gear

1. Temporary assemble the spiral bevel pinion shaft, and properly adjust the side clearance.
2. Place fuses between spiral bevel pinion shaft and spiral bevel gear (2). (Several points on the circumferential)
3. Assemble the axle cover assembly, and turn the rear axle.
4. Remove the axle cover assembly, and take out the fuses.
5. Measure the thickness of fuses with an outside micrometer. (Backlash equal thickness of fuse.)
6. If the measurement is not within the factory specifications, adjust with shims (4).

Backlash between spiral bevel pinion shaft and spiral bevel gear	Factory spec.	0.1 to 0.3 mm 0.0039 to 0.0118 in.
--	---------------	---------------------------------------

(Reference)

- Thickness of shims:
0.3 mm (0.0118 in.), 0.6 mm (0.0236 in.), 0.8 mm (0.0315 in.)
1.0 mm (0.0394 in.), 1.2 mm (0.0472 in.), 1.4 mm (0.0551 in.)

- | | |
|-----------------------|----------------------|
| (1) Transmission Case | (4) Shim |
| (2) Spiral Bevel Gear | (5) Final Gear Shaft |
| (3) Axle Cover | |

W1030394

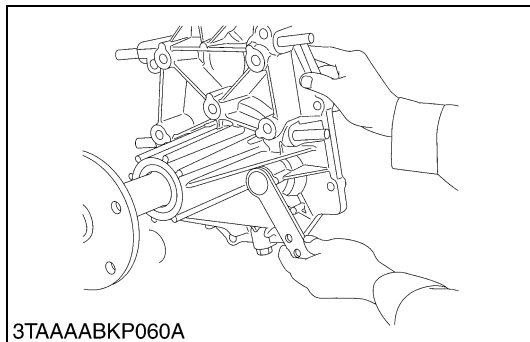

3TAAAABKP060A

Brake Cam Lever Movement

1. Move the brake cam lever by hand to check the movement.
2. If the movement is heavy, refine the brake cam with emery paper.

W1030594

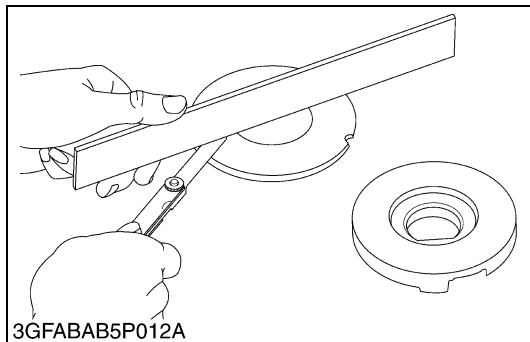

3GFABAB5P012A

Flatness of Actuator and Bearing Holder

1. Place a straightedge of 150 mm (5.91 in.) or more in length on the contacting surface of the actuator and the bearing holder.
2. Inspect the friction surface of the actuator and the bearing holder with the straightedge, and determine if a 0.30 mm (0.0118 in.) feeler gauge will fit on the part of wear.
3. If it will fit, resurface.

Flatness of actuator and bearing holder	Allowable limit	0.30 mm 0.0118 in.
---	-----------------	-----------------------

W1030671



3GFABAB5P013A

Height of Cam Plate and Ball

1. Measure the height of the cam plate with the ball installed.
2. If the measurement is less than the allowable limit, replace the cam plate and balls.
3. Inspect the ball holes of cam plate for uneven wear.
4. If the uneven wear is found, replace it.

Height of cam plate and ball	Factory spec.	22.89 to 22.99 mm 0.9012 to 0.9051 in.
	Allowable limit	22.40 mm 0.8819 in.

W1030769

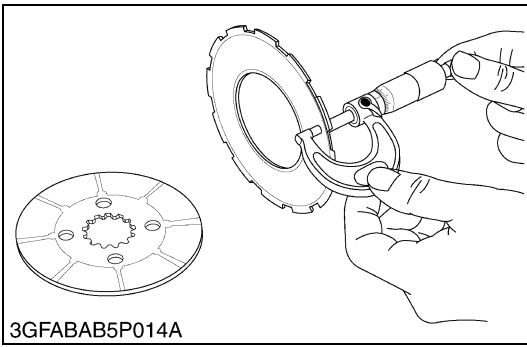

Brake Disc and Friction Plate Wear

1. Measure the brake disc thickness and the friction plate thickness with an outside micrometer.
2. If the thickness is less than the allowable limit, replace it.

Brake disc thickness	Factory spec.	3.3 to 3.5 mm 0.130 to 0.138 in.
	Allowable limit	3.0 mm 0.118 in.

Friction plate thickness	Factory spec.	1.92 to 2.08 mm 0.0756 to 0.0819 in.
	Allowable limit	1.52 mm 0.0598 in.

W1030890

3 FRONT AXLE

MECHANISM

CONTENTS

1. STRUCTURE	3-M1
2. FRONT WHEEL ALIGNMENT	3-M2

1. STRUCTURE

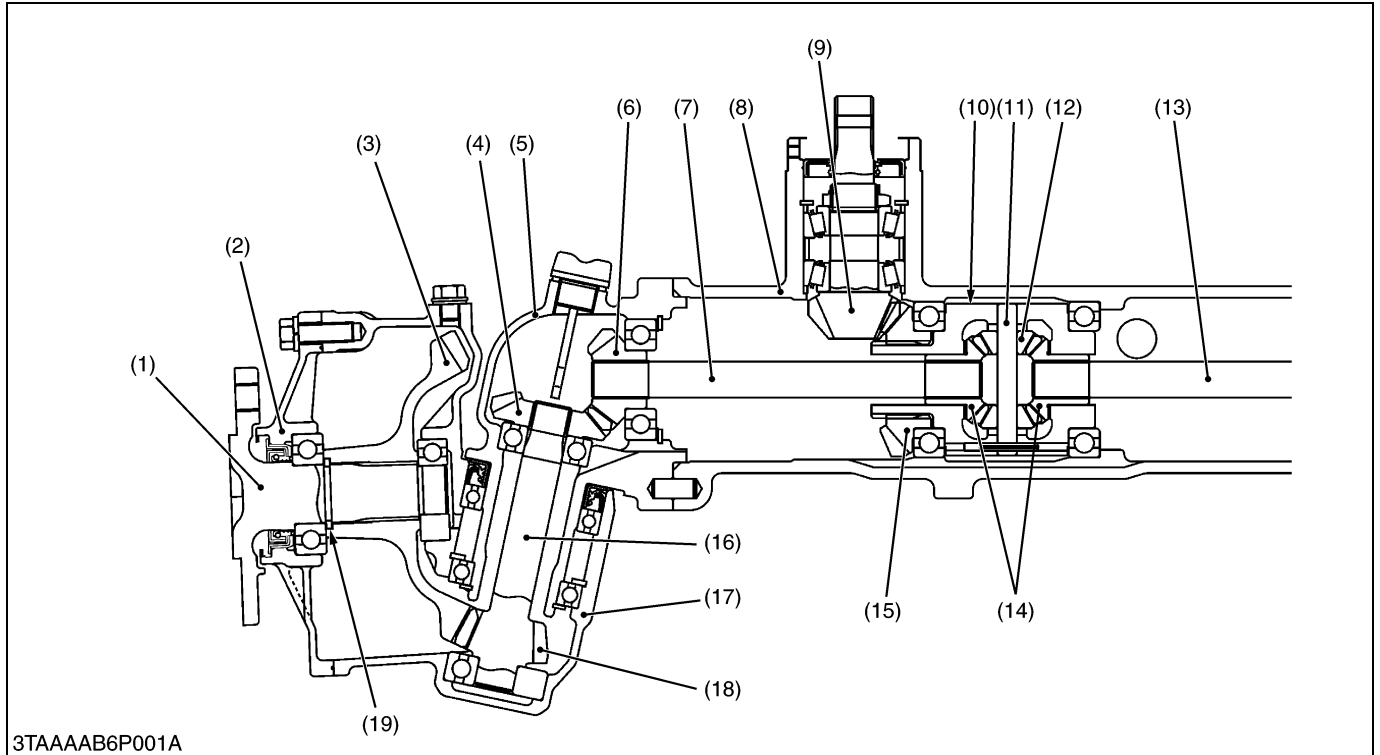

- | | | | |
|---------------------|---------------------------------|----------------------------------|-----------------------|
| (1) Axle | (6) Bevel Gear | (11) Differential Pinion Shaft | (16) Bevel Gear Shaft |
| (2) Axle Flange | (7) Differential Yoke Shaft, RH | (12) Differential Pinion Gear | (17) Front Gear Case |
| (3) Bevel Gear | (8) Front Axle Case | (13) Differential Yoke Shaft, LH | (18) Bevel Gear |
| (4) Bevel Gear | (9) Spiral Bevel Pinion Shaft | (14) Differential Side Gear | (19) Collar |
| (5) Bevel Gear Case | (10) Differential Gear Assembly | (15) Spiral Bevel Gear | |

The front axle of the 4WD is constructed as shown above. Power is transmitted from the transmission through the propeller shaft to the spiral bevel pinion shaft (9), then to the spiral bevel gear (15) and to the differential side gear (14).

The power through the differential side gear is transmitted to the differential yoke shaft (7), (13), and to the bevel gear shaft (16) through the bevel gears (4), (6) in the bevel gear case (5).

The revolution is greatly reduced by the bevel gears (18), (3), then the power is transmitted to the axle (1).

The differential system allows each wheel to rotate at a different speed to make turning easier.

2. FRONT WHEEL ALIGNMENT

To assure smooth mobility or maneuverability and enhance stable and straight running, the front wheels are mounted at an angle to the right, left and forward directions. This arrangement is referred to as the Front Wheel Alignment.

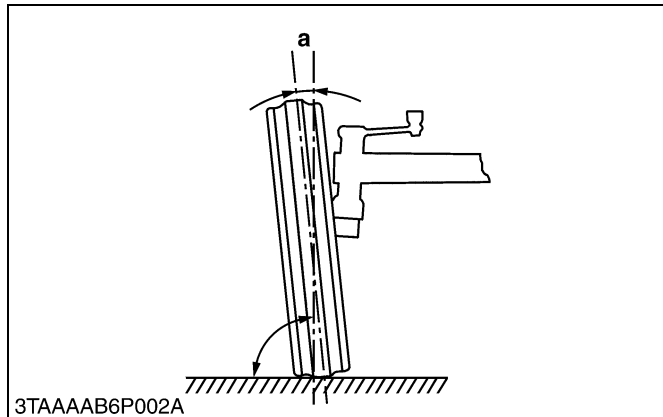

■ Camber

The front wheels are tilted from the vertical as viewed from the front, upper wheels are spreader than lower ones.

This inclination is called camber (**a**). Camber reduces bending or twisting of the front axle caused by vertical load or running resistance, and also maintains the stability in running.

Camber	0.035 rad. 2 °
--------	-------------------

W1012811

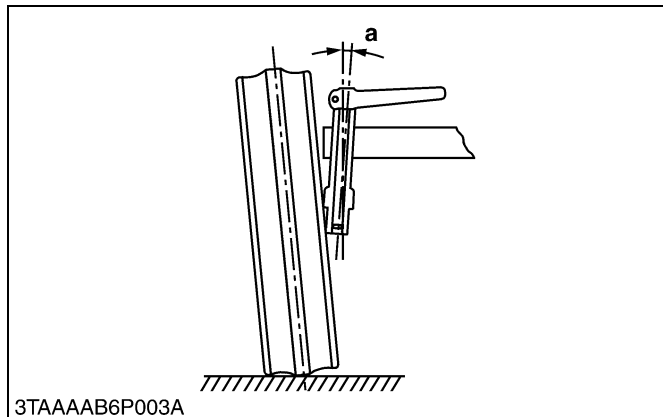

■ Kingpin Angle

The Kingpin is titled from the vertical as viewed from the front.

This angle is called kingpin angle (**a**). As with the camber, kingpin angle reduces rolling resistance of the wheels, and prevents any shimmy motion of the steering wheel.

It also reduces steering effort.

Kingpin angle	0.209 rad. 12 °
---------------	--------------------

W1013073

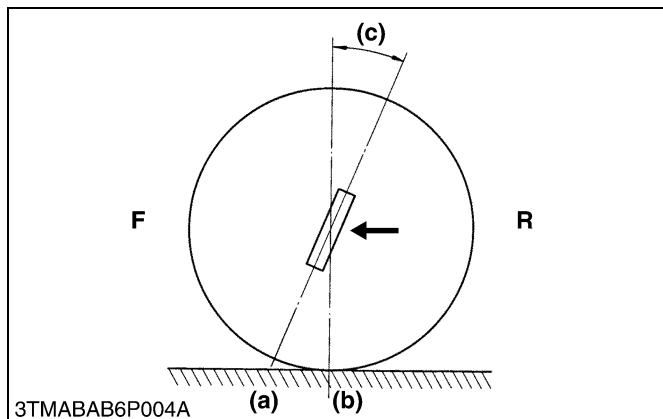

■ Caster

The kingpin is titled forward as viewed from the side. The point (**b**) of the wheel center line is behind the point (**a**) of the kingpin shaft center line.

This inclination is called caster (**c**). Caster helps provide steering stability.

As with the kingpin inclination, caster reduces steering effort.

Camber	0 rad. 0 °
--------	---------------

F : Front

R : Rear

W1013142

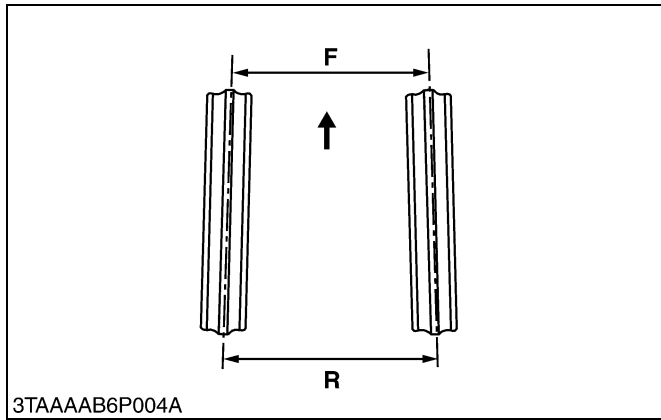

■ **Toe-in**

Viewing the front wheels from above reveals that the distance between the toes of the front wheels is smaller than that between the heels.

It is called toe-in. The front wheels tend to roll outward due to the camber, but toe-in offsets it and ensures parallel rolling of the front wheels. Another purpose of toe-in is to prevent excessive and uneven wear of tires.

Toe-in	1 to 10 mm 0.04 to 0.39 in.
--------	--------------------------------

F : Front

R : Rear

W1013242

SERVICING

CONTENTS

1. TROUBLESHOOTING	3-S1
2. SERVICING SPECIFICATIONS	3-S2
3. TIGHTENING TORQUES	3-S3
4. CHECKING, DISASSEMBLING AND SERVICING.....	3-S4
[1] CHECKING AND ADJUSTING	3-S4
[2] DISASSEMBLING AND ASSEMBLING.....	3-S5
(1) Separating Front Axle Assembly.....	3-S5
(2) Disassembling Front Axle Assembly.....	3-S8
[3] SERVICING	3-S12

1. TROUBLESHOOTING

Symptom	Probable Cause	Solution	Reference Page
Front Wheels Wander to Right or Left	<ul style="list-style-type: none"> • Tire pressure uneven • Improper toe-in adjustment (improper alignment) • Clearance between center pin and shaft support bushing excessive • Front axle rocking force too small • Tie-rod end loose • Air sucked in power steering circuit 	Adjust Adjust Replace Adjust Tighten Bleed	G-35 G-21, 3-S4 3-S14 3-S4 3-S8 –
Front Wheels Can Not Be Driven	<ul style="list-style-type: none"> • Front wheel driving gears in front axle gear case broken • Universal joint broken • Front wheel drive gears in transmission broken • Front differential gear broken 	Replace Replace Replace Replace	3-S8 3-S7 – 3-S11
Noise	<ul style="list-style-type: none"> • Gear backlash excessive • Oil insufficient • Bearings damaged or broken • Gears damaged or broken • Spiral bevel pinion shaft turning force improper 	Adjust or replace Replenish Replace Replace Adjust	3-S13 3-S5 – – 3-S13

W1014322

2. SERVICING SPECIFICATIONS

Item		Factory Specification	Allowable Limit
Front Wheel Alignment	Toe-in	1 to 10 mm 0.04 to 0.39 in.	–
Front Axle	Rocking Force	49.0 to 117.7 N 5.0 to 12.0 kgf 11.0 to 26.5 lbs	–
Differential Case to Differential Side Gear	Clearance	0.040 to 0.082 mm 0.00157 to 0.00323 in.	0.17 mm 0.0067 in.
Differential Case	I.D.	26.000 to 26.021 mm 1.02362 to 1.02445 in.	–
Differential Side Gear	O.D.	25.939 to 25.960 mm 1.02122 to 1.02205 in.	–
Differential Pinion Shaft to Differential Pinion	Clearance	0.025 to 0.055 mm 0.00098 to 0.00217 in.	0.25 mm 0.0096 in.
Differential Pinion Shaft	O.D.	9.960 to 9.975 mm 0.39212 to 0.39272 in.	–
Differential Pinion	I.D.	10.000 to 10.015 mm 0.39370 to 0.39429 in.	–
Differential Pinion to Differential Side Gear	Backlash	0.1 to 0.3 mm 0.004 to 0.012 in.	–
Bevel Pinion Shaft	Turning Torque	0.8 to 1.0 N·m 0.08 to 0.10 kgf·m 0.59 to 0.73 ft-lbs	–
Bevel Pinion Shaft to Spiral Bevel Gear	Backlash	0.1 to 0.3 mm 0.004 to 0.012 in.	–
12T Bevel Gear to 15T Bevel Gear	Backlash	0.1 to 0.3 mm 0.004 to 0.012 in.	–
Center Pin to Pin Support Bush	Clearance	0 to 0.231 mm 0 to 0.00909 in.	0.70 mm 0.0276 in.
Center Pin	O.D.	19.850 to 20.000 mm 0.78149 to 0.78740 in.	–
Bush	I.D.	20.000 to 20.081 mm 0.78740 to 0.79059 in.	–

W1013874

3. TIGHTENING TORQUES

Tightening torques of screws, bolts and nuts on the table below are especially specified.
(For general use screws, bolts and nuts : See page G-8.)

Item	N·m	kgf·m	ft-lbs
Under cover mounting bolt and nut	7.8 to 8.8	0.8 to 0.9	5.8 to 6.5
Power steering cylinder hose	28.4 to 30.0	2.9 to 3.1	20.9 to 22.1
Front wheel mounting screw	149.2 to 179.0	15.3 to 18.2	110 to 132
Center pin slotted nut	19.6	2.0	14.5
Tie-rod slotted nut	17.7 to 34.3	1.8 to 3.5	13.0 to 25.3
Bevel gear case mounting screw	77.5 to 90.1	7.9 to 9.2	57.1 to 66.5
Front gear case cover mounting screw	77.5 to 90.1	7.9 to 9.2	57.1 to 66.5

W1012736

4. CHECKING, DISASSEMBLING AND SERVICING

[1] CHECKING AND ADJUSTING

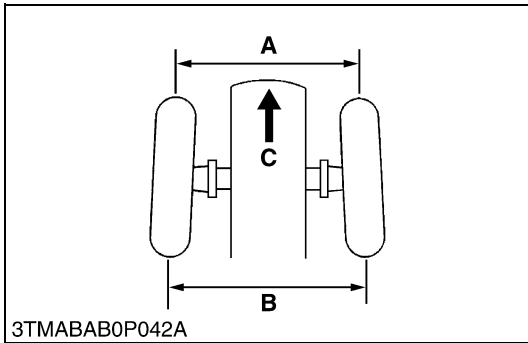

Toe-in

1. Inflate the tires to the specified pressure.
2. Turn the front wheels straight ahead.
3. Measure the toe-in (B-A).
4. If the measurement is not within the factory specifications, adjust the tie-rod length.

Toe-in (B-A)	Factory spec.	1 to 10 mm 0.04 to 0.39 in.
--------------	---------------	--------------------------------

(A) Wheel to Wheel Distance at Front (C) Front
(B) Wheel to Wheel Distance at Rear

W1011333

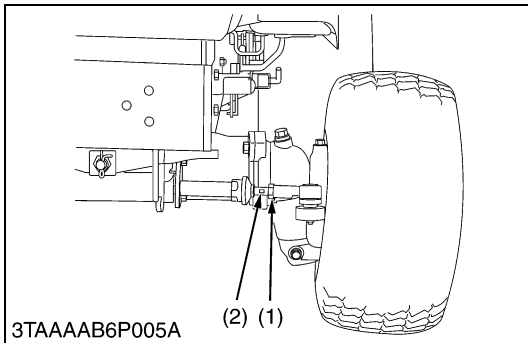

Toe-in Adjusting

1. Loosen the lock nuts (1).
2. Turn the tie-rod (2) until to be factory specification.
3. Tighten the lock nuts (1).

(1) Lock Nut

(2) Tie-rod

W1011497

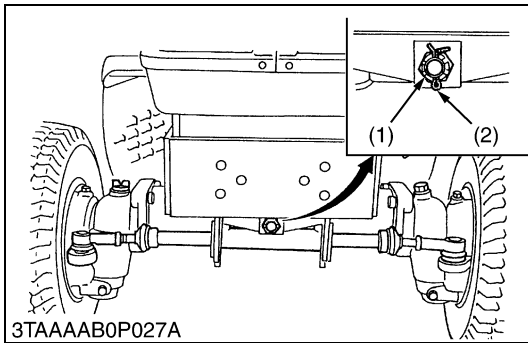

Front Axle Rocking Force

1. Jack up the front side of tractor and remove the front wheel.
2. Set a spring balance to the front gear case cover.
3. Measure the front axle rocking force.
4. If the measurement is not within the factory specifications, adjust as following.

■ Adjusting procedure

1. Remove the cotter pin (2).
2. Tighten or loosen the adjusting nut (1) so that the measurement of rocking force comes to factory specifications.
3. If the slot and pin hole do not meet, align the nut until they do meet within factory specifications.
4. Install the new cotter pin.

(When reassembling)

- Be sure to split the cotter pin like an anchor.

(Reference)

- Tightening torque of adjusting nut:
19.6 N·m (2.0 kgf·m, 14.5 ft-lbs)

Front axle rocking force	Factory spec.	49.0 to 177.7 N 5.0 to 12.0 kgf 11.0 to 26.5 lbs
--------------------------	---------------	--

(1) Adjusting Nut

(2) Cotter Pin

W1011602

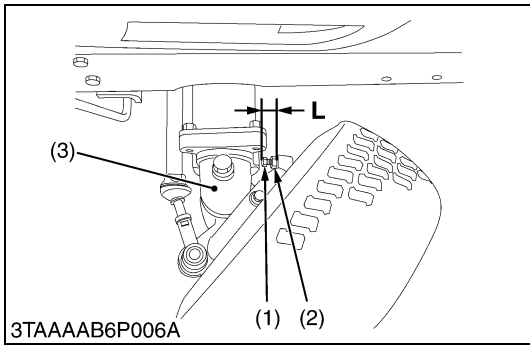

Front Wheel Steering Angle

1. Inflate the tires to the specified pressure.
2. Loosen the lock nut and shorten the length of stopper bolt LH (1).
3. Steer the wheels to the extreme left.
4. Lengthen the length of stopper bolt (1) until the stopper bolt contacts with the bevel gear case (3).
5. Return the steering wheel to straight ahead and lengthen the stopper bolt half turn from above position further.
6. Lock the stopper bolt by lock nut (2).
7. For adjusting the right steering angle, perform the same procedure as mentioned in left steering angle.

(Reference)

- Length of adjusting bolt L : Right side 25 mm (0.98 in.)
Left side 20 mm (0.79 in.)
- Steering angle : Right side 0.84 to 0.87 rad. (48 to 50 °)
Left side 0.92 to 0.96 rad. (53 to 55 °)

- (1) Stopper Bolt LH
- (2) Lock Nut

- (3) Bevel Gear Case

W1011846

[2] DISASSEMBLING AND ASSEMBLING

(1) Separating Front Axle Assembly

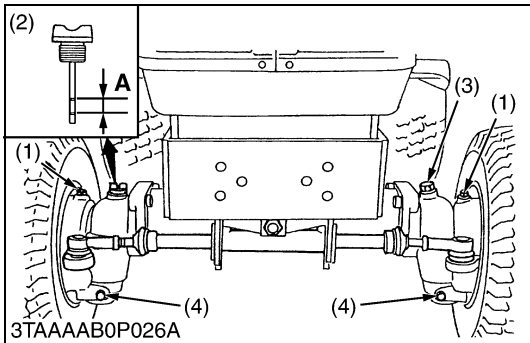

Draining Front Axle Case Oil

1. Place the oil pans underneath the front axle case.
2. Remove the both right and left hand side drain plugs (4) and filling plug (3) to drain the oil.
3. After draining, reinstall the drain plugs (4).

(When reassembling)

- When re-filling, remove the right and left breather plugs (1).

■ IMPORTANT

- After ten minutes, check the oil level again, add oil to prescribed level.
- Use KUBOTA SUPER UDT fluid or SAE80, 90 gear oil. Refer to "LUBRICANTS, FUEL AND COOLANT". (See page G-7.)

Front axle case oil capacity	4.7 L 4.97 U.S.qts. 4.14 Imp.qts.
------------------------------	---

- (1) Breather Plug
- (2) Filling Plug with Dipstick
- (3) Filling Plug
- (4) Drain Plug

A : Oil level is acceptable within this range.

W1012192

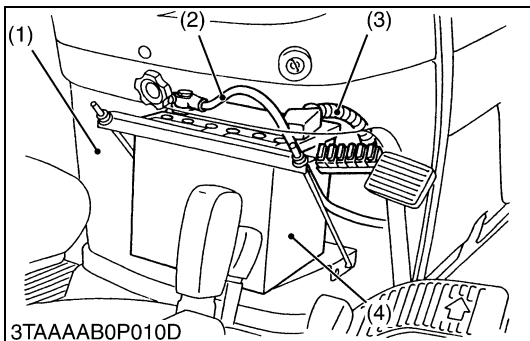

Battery

⚠ CAUTION

- When disconnecting the battery cables, disconnect the negative cable from the battery first. When connecting, connect the positive cable to the battery first.
1. Remove the under panel (1).
 2. Disconnect the negative cable (2) from the battery.
 3. Disconnect the positive cable (3) from the battery and remove the battery (4).

- (1) Under Panel
- (2) Negative Cable

- (3) Positive Cable
- (4) Battery

W1012394

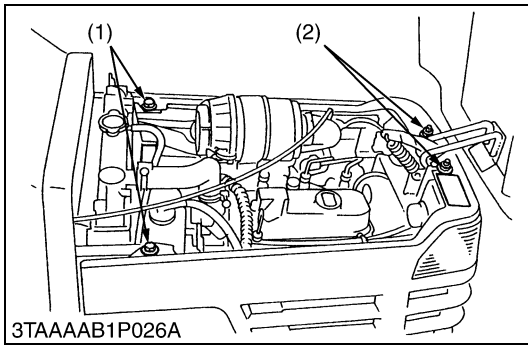

Under Cover

1. Remove the under cover mounting bolts (1), loosen the mounting nuts (2) and pull forward to remove the under cover (3).

(When reassembling)

Tightening torque	Under cover mounting bolt and nut	7.8 to 8.8 N·m 0.8 to 0.9 kgf·m 5.8 to 6.5 ft·lbs
-------------------	-----------------------------------	---

- (1) Under Cover Mounting Bolt (3) Under Cover
(2) Under Cover Mounting Nut

W1012507

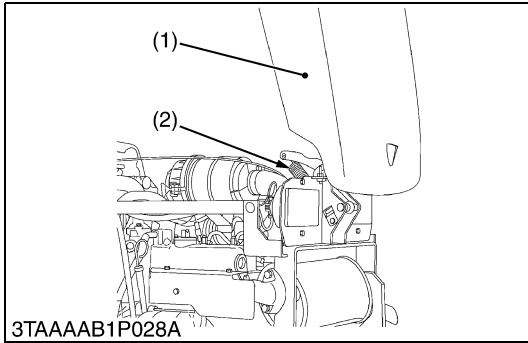
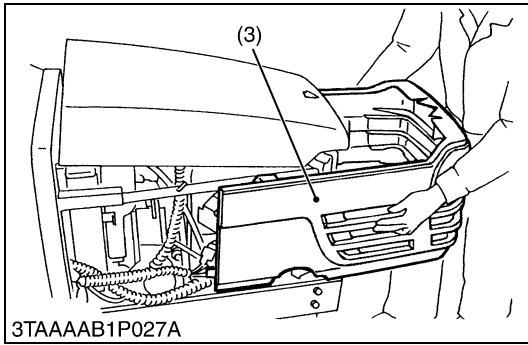

Bonnet

1. Remove the spring (2).
2. Remove the bonnet mounting bolt and nut, and remove the bonnet (1).

- (1) Bonnet (2) Spring

W1012617

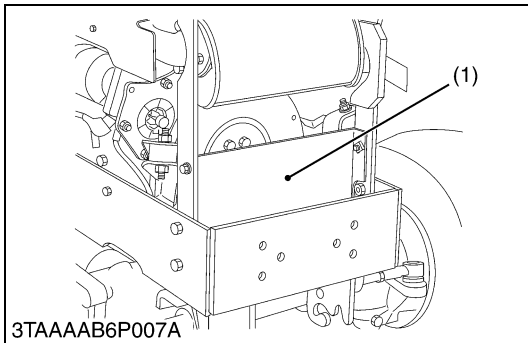

Flywheel Cover and Power Steering Hose

1. Remove the flywheel cover (1).
2. Disconnect the power steering cylinder hoses (2).

(When reassembling)

Tightening torque	Power steering cylinder hose	28.4 to 30.0 N·m 2.9 to 3.1 kgf·m 20.9 to 22.1 ft·lbs
-------------------	------------------------------	---

- (1) Flywheel Cover (2) Power Steering Cylinder Hose

W1012698

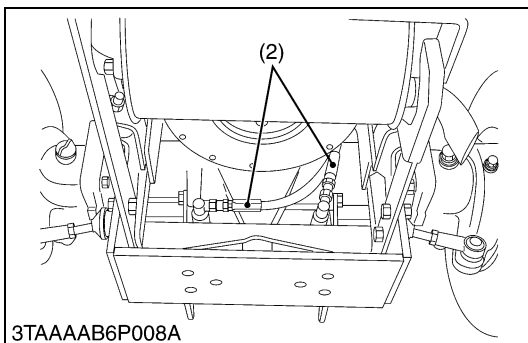

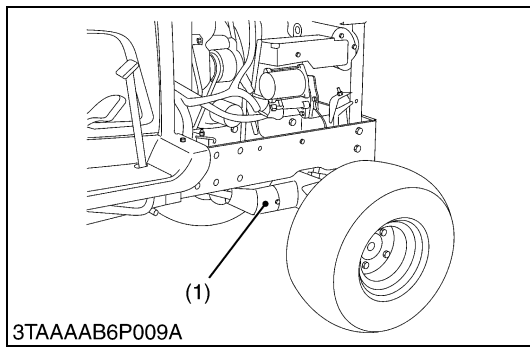

Front Wheel and Propeller Shaft Cover

1. Lift up the front side of tractor and place the disassembling stand under the front axle frame.
2. Remove the front wheels.
3. Remove the propeller shaft cover mounting bolt and slide the propeller shaft cover (1).

(When reassembling)

Tightening torque	Front wheel mounting screw	149.2 to 179.0 N·m 15.3 to 18.2 kgf·m 110 to 132 ft-lbs
-------------------	----------------------------	---

(1) Propeller Shaft Cover

W1012838

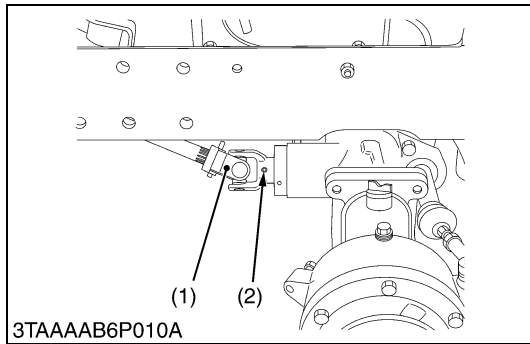

Disconnecting Propeller Shaft

1. Tap out the spring pins (2) and disconnect the universal joint (1) and spiral bevel pinion shaft.

(When reassembling)

- Apply grease to the splines of the propeller shaft and universal joint.
- When inserting the spring pins (2), face their splits in the direction parallel to the universal joint as shown in the figure.

(1) Universal Joint

(2) Spring Pin

W1013075

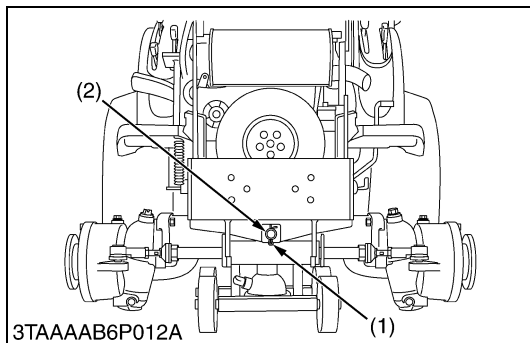
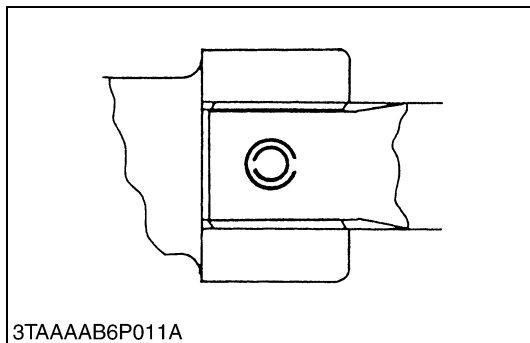

Front Axle Assembly

1. Place the disassembling stand under the front axle.
2. Remove the cotter pin (1).
3. Remove the slotted nut (2) of center pin and separate the front axle from the frame.

(When reassembling)

- After mounting the front axle assembly to the frame, be sure to adjust the front axle rocking force. (See page 3-S4.)
- Installing the cotter pin and be sure to split the cotter pin like an anchor.

Tightening torque	Center pin slotted nut	19.6 N·m 2.0 kgf·m 14.5 ft-lbs
-------------------	------------------------	--------------------------------------

(1) Cotter Pin

(2) Slotted Nut (Adjusting nut for front axle rocking force)

W1013203

(2) Disassembling Front Axle Assembly

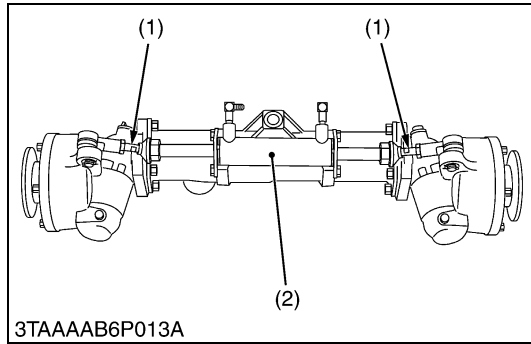

Power Steering Cylinder

1. Remove the cotter pin and remove the slotted nut for tie-rod (1).
2. Remove the power steering cylinder mounting screws and remove the power steering cylinder (2) with tie-rod.

(When reassembling)

■ NOTE

- Tighten the slotted nut to **17.7 N·m (1.8 kgf·m, 13 ft-lbs)**. If the slot and pin hole do not meet, tighten the nut until they do meet, and install the cotter pin.
- Be sure to split the cotter pin like an anchor.

Tightening torque	Tie-rod slotted nut	17.7 to 34.3 N·m 1.8 to 3.5 kgf·m 13.0 to 25.3 ft-lbs
-------------------	---------------------	---

(1) Tie-rod

(2) Power Steering Cylinder

W1013368

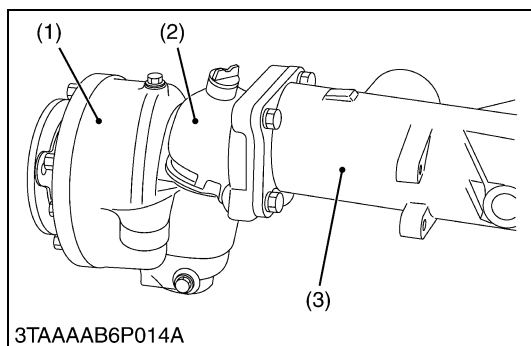

Bevel Gear Case and Front Gear Case

1. Remove the bevel gear case mounting screws.
2. Remove the bevel gear case (2) and front gear case (1) as a unit from the front axle case (3).

(When reassembling)

- Apply grease to the O-ring and take care not to damage it.
- Do not interchange right and left bevel gear case assemblies and right and left gear case assemblies.

Tightening torque	Bevel gear case mounting screw	77.5 to 90.1 N·m 7.9 to 9.2 kgf·m 57.1 to 66.5 ft-lbs
-------------------	--------------------------------	---

(1) Front Gear Case

(3) Front Axle Case

(2) Bevel Gear Case

W1013787

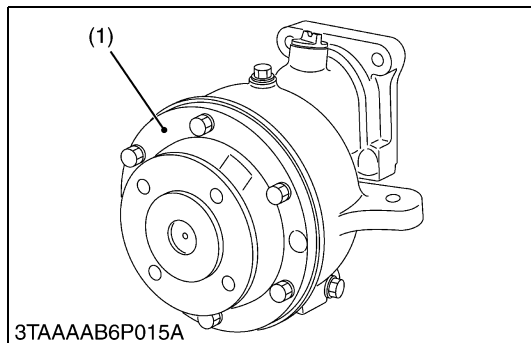

Front Gear Case Cover

1. Remove the front gear case mounting screws and remove the front gear case cover (1) with bevel gear (2).

(When reassembling)

- Apply liquid gasket (Three Bond 1208D or equivalent) to joint face of the gear case cover (1) and front gear case (3) after eliminate the water, oil and stuck liquid gasket.

Tightening torque	Front gear case cover mounting screw	77.5 to 90.1 N·m 7.9 to 9.2 kgf·m 57.1 to 66.5 ft-lbs
-------------------	--------------------------------------	---

(1) Front Gear Case Cover

(3) Front Gear Case

(2) Bevel Gear

W1013952

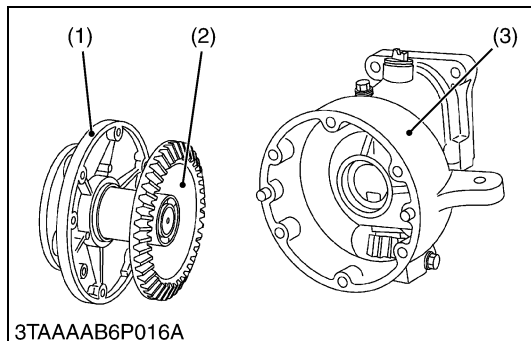

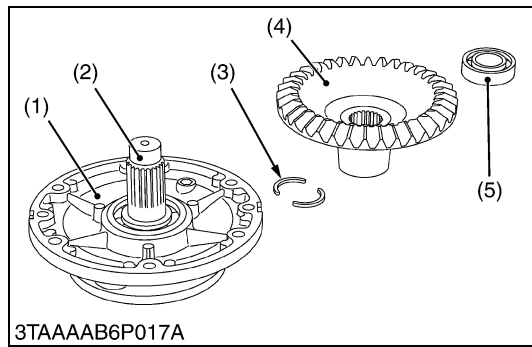

36T Bevel Gear and Front Axle Shaft

1. Remove the bearing (5).
2. Take out the 36T bevel gear (4).
3. Take out the collar (3).
4. Tap out the axle shaft (2).

(When reassembling)

- Install the oil seal (6) of front gear case cover (1), noting its direction as shown in the figure.

- | | |
|---------------------------|--------------------|
| (1) Front Gear Case Cover | (4) 36T Bevel Gear |
| (2) Axle Shaft | (5) Ball Bearing |
| (3) Collar | (6) Oil Seal |

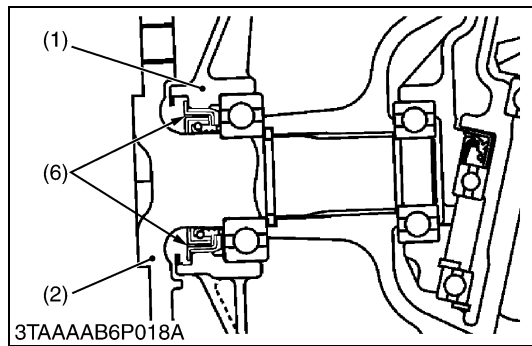

W1014087

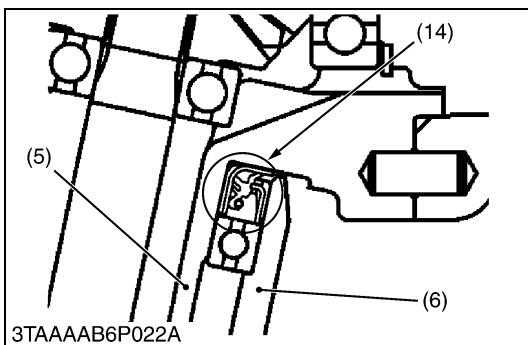
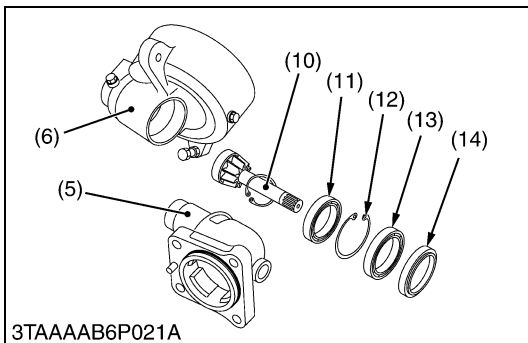
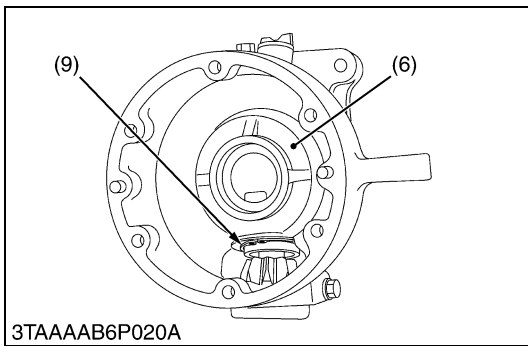
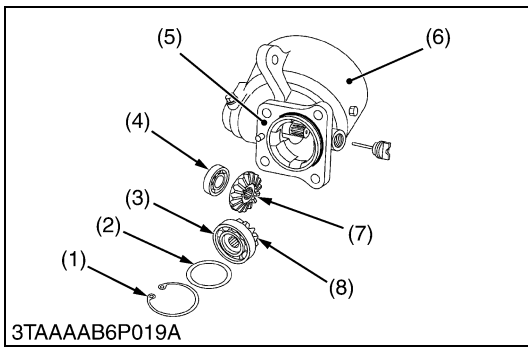

Front Gear Case and Bevel Gear Case

1. Remove the internal snap ring (1).
2. Remove the 12T bevel gear (8) with ball bearing (3) and shim (2).
3. Remove the 15T bevel gear (7) and ball bearing (4).
4. Remove the external snap ring (9).
5. Remove the bevel gear case (5) from front gear case (6).
6. Remove the oil seal (14) and the ball bearing (13).
7. Remove the internal snap ring (12) and remove the ball bearing (11).
8. Remove the bevel gear shaft (10) with ball bearing.

(When reassembling)

- Install the oil seal (14) of bevel gear case, noting its direction as shown in the figure.
- Install the adjusting shims (2) to their original position.

- | | |
|------------------------|-------------------------|
| (1) Internal Snap Ring | (8) 12T Bevel Gear |
| (2) Shim | (9) External Snap Ring |
| (3) Ball Bearing | (10) Bevel Gear Shaft |
| (4) Ball Bearing | (11) Ball Bearing |
| (5) Bevel Gear Case | (12) Internal Snap Ring |
| (6) Front Gear Case | (13) Ball Bearing |
| (7) 15T Bevel Gear | (14) Oil Seal |

W1014354

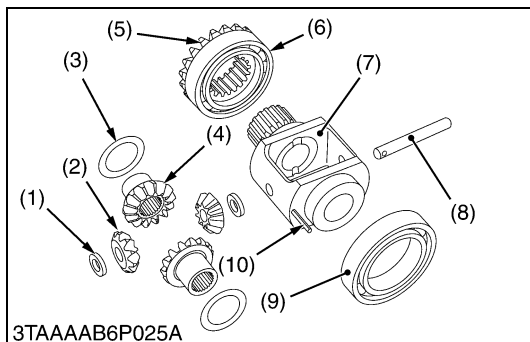
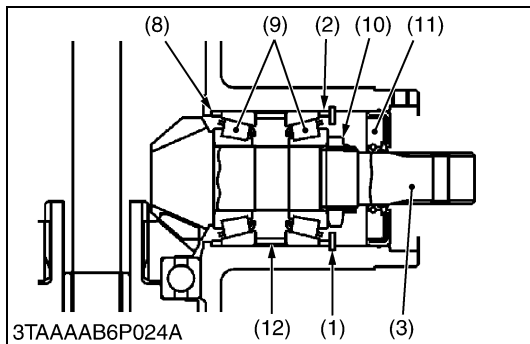
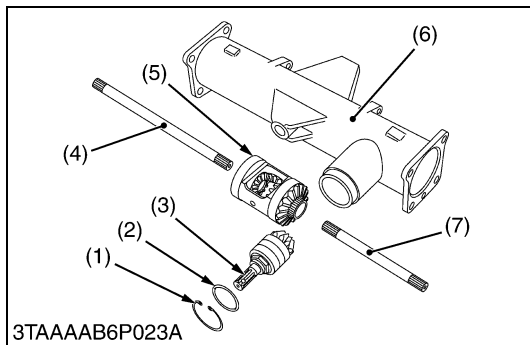

Bevel Pinion Shaft and Differential Gear Assembly

1. Take out the differential yoke shaft (4), (7).
2. Remove the oil seal (11).
3. Remove the internal snap ring (1).
4. Pull out the bevel pinion shaft (3).
5. Take out the differential gear assembly (5), from right side of front axle case (6).
6. Remove the stake of lock nut (10), and then remove the lock nut (10).
7. Remove the taper roller bearings (9).

(When reassembling)

- Apply gear oil to the taper roller bearings (9) and install them correctly, noting their direction.
- Replace the lock nut (10) and oil seal (11) with new ones.
- After tighten the lock nut (10) to the specified torque, stake it firmly.
- Install the adjusting collars (2), (8) to their original position.

- | | |
|--------------------------------|--------------------------------|
| (1) Internal Snap Ring | (7) Differential Yoke Shaft RH |
| (2) Adjusting Collar | (8) Adjusting Collar |
| (3) Bevel Pinion Shaft | (9) Taper Roller Bearing |
| (4) Differential Yoke Shaft LH | (10) Lock Nut |
| (5) Differential Gear Assembly | (11) Oil Seal |
| (6) Front Axle Case | (12) Collar |

W1014794

Differential Gear

1. Remove the bevel gear (5) with bearing (6) and bearing (9) by puller.
2. Tap out the spring pin (10) from bevel gear side.
3. Remove the differential pinion shaft (8).
4. Remove the differential pinions (2), differential side gears (4) and shims (1), (3).

NOTE

- **Arrange the parts to know their original position.**

(When reassembling)

- Apply molybdenum disulfide (Three Bond 1901 or equivalent) to the inner circumferential surface of the differential side gears, differential pinions and shims.

- | | |
|----------------------------|-------------------------------|
| (1) Shim | (6) Ball Bearing |
| (2) Differential Pinion | (7) Differential Gear Case |
| (3) Shim | (8) Differential Pinion Shaft |
| (4) Differential Side Gear | (9) Ball Bearing |
| (5) Bevel Gear | (10) Spring Pin |

W1015222

[3] SERVICING

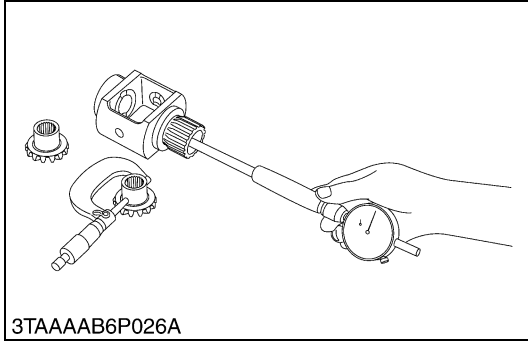

Clearance between Differential Case and Differential Side Gear

1. Measure the differential side gear boss O.D..
2. Measure the differential case bore I.D., and calculate the clearance.
3. Measure the differential case cover bore I.D., and calculate the clearance.
4. If the clearance exceeds the allowable limit, replace faulty parts.

Clearance between differential case and differential side gear	Factory spec.	0.040 to 0.082 mm 0.00157 to 0.00323 in.
	Allowable limit	0.17 mm 0.0067 in.

Differential case bore I.D.	Factory spec.	26.000 to 26.021 mm 1.02362 to 1.02445 in.
Differential side gear O.D.	Factory spec.	25.939 to 25.960 mm 1.02122 to 1.02205 in.

W1015523

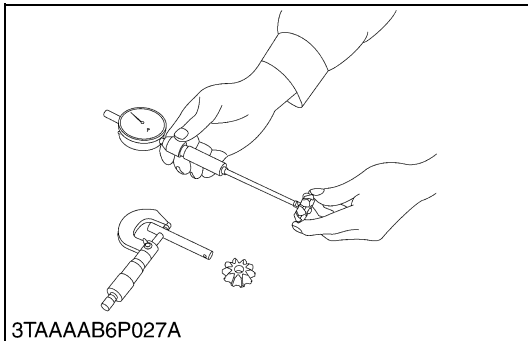

Clearance between Differential Pinion Shaft and Differential Pinion

1. Measure the differential pinion shaft O.D..
2. Measure the differential pinion I.D., and calculate the clearance.
3. If the clearance exceeds the allowable limit, replace faulty parts.

Clearance between differential pinion shaft and differential pinion	Factory spec.	0.025 to 0.055 mm 0.00098 to 0.00217 in.
	Allowable limit	0.25 mm 0.0096 in.

Differential pinion shaft O.D.	Factory spec.	9.960 to 9.975 mm 0.39212 to 0.39272 in.
Differential side gear I.D.	Factory spec.	10.000 to 10.015 mm 0.39370 to 0.39429 in.

W1015675

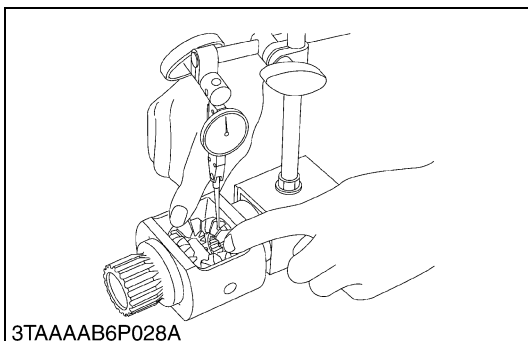

Backlash between Differential Pinion and Differential Side Gear

1. Set a dial gauge (lever type) on a tooth of the differential pinion.
2. Fix the differential side gear, and move the differential pinion to measure the backlash.
3. If the measurement exceeds the factory specifications, adjust with the differential side gears shims.

Backlash between differential pinion and differential side gear	Factory spec.	0.1 to 0.3 mm 0.004 to 0.012 in.
---	---------------	-------------------------------------

(Reference)

- Thickness of adjusting shims :
 - For side gear : 0.8 mm (0.031 in.), 1.0 mm (0.039 in.)
1.2 mm (0.047 in.)
 - For pinion : 3.3 mm (0.130 in.), 3.5 mm (0.138 in.)
3.7 mm (0.146 in.), 3.9 mm (0.154 in.)

W1015817

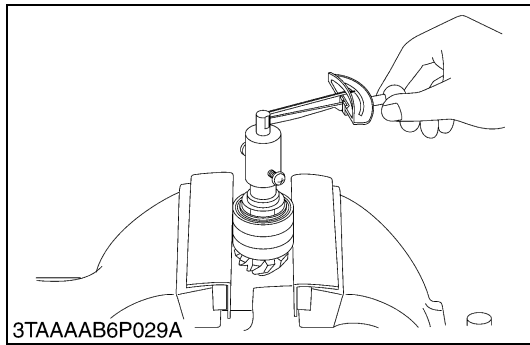

3TAAAB6P029A

Turning Torque of Bevel Pinion Shaft

1. Cramp the spiral bevel pinion shaft assembly to the vise and tighten the staking nut.
2. Measure the turning torque of bevel pinion shaft.
3. If the turning torque is not within the factory specifications, adjust with the lock nut.

Turning torque	Factory spec.	0.8 to 1.0 N·m 0.08 to 0.10 kgf·m 0.59 to 0.73 ft·lbs
----------------	---------------	---

NOTE

- After turning force adjustment, be sure to stake the lock nut. W10206520

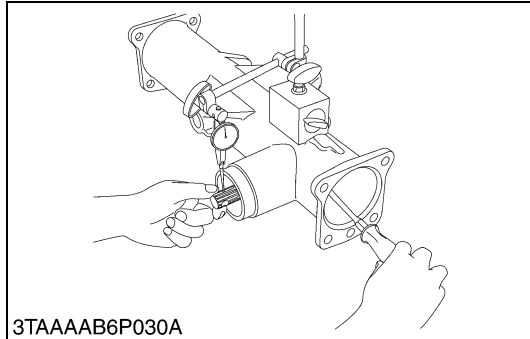

3TAAAB6P030A

Backlash between Bevel Pinion Shaft and Bevel Gear

1. Set a dial gauge (lever type) with its finger on the spline of bevel pinion shaft.
2. Fix the bevel gear and measure the backlash by moving the bevel pinion shaft by hand lightly.
3. If the backlash is not within the factory specifications, change the adjusting collars (3), (4). For example change the adjusting collar (4) to 0.1 mm (0.004 in.) smaller size, and change the adjusting collar (3) to 0.1 mm (0.004 in.) larger size.
4. Adjust the backlash properly by repeating the above procedures.

Backlash between bevel pinion shaft and bevel gear	Factory spec.	0.1 to 0.3 mm 0.004 to 0.012 in.
--	---------------	-------------------------------------

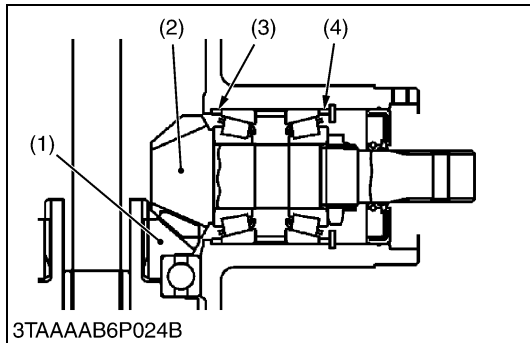

3TAAAB6P024B

(Reference)

- Above factory specification should be measured on the tooth of bevel pinion. When measuring the backlash on the spline of its shaft, factory specification will be 0.0571 to 0.1714 mm (0.00225 to 0.00675 in.).
- Thickness of adjusting collars (3), (4) :

3.4 mm (0.134 in.)	4.1 mm (0.161 in.)
3.6 mm (0.142 in.)	4.2 mm (0.165 in.)
3.8 mm (0.150 in.)	4.4 mm (0.173 in.)
3.9 mm (0.154 in.)	4.5 mm (0.177 in.)
4.0 mm (0.157 in.)	4.6 mm (0.181 in.)

- | | |
|------------------------|----------------------|
| (1) Bevel Gear | (3) Adjusting Collar |
| (2) Bevel Pinion Shaft | (4) Adjusting Collar |

W10207820

4 STEERING

MECHANISM

CONTENTS

1. HYDRAULIC CIRCUIT.....	4-M1
2. STEERING CONTROLLER.....	4-M2
3. STEERING CYLINDER.....	4-M3

1. HYDRAULIC CIRCUIT

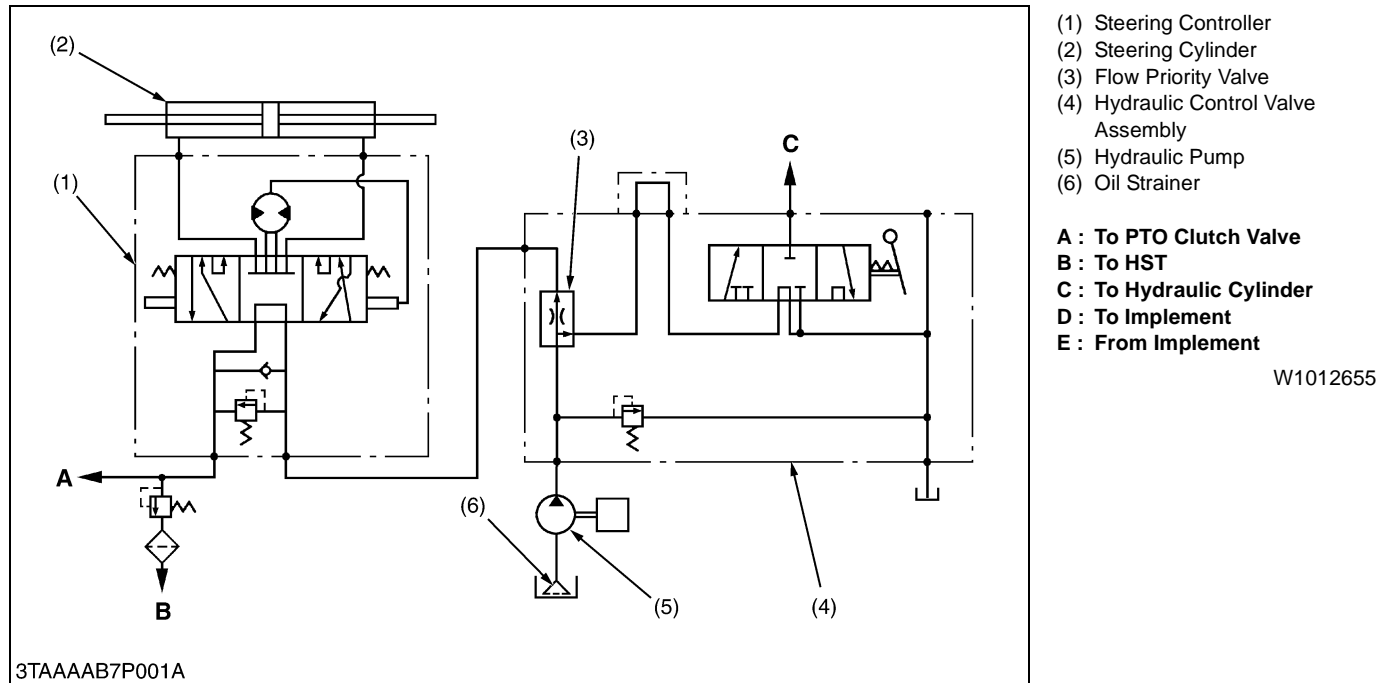

This model is provided with a full hydrostatic power steering.

In the full hydrostatic power steering, the steering controller is connected to the steering cylinder with only the hydraulic piping. Accordingly, it does not have mechanical transmitting parts such as steering gear, pitman arm, drag link, etc.. Therefore, it is simple in construction. This steering system consists of the oil strainer (6), hydraulic pump (5), flow priority valve (3), steering controller (1), steering cylinder (2), etc..

Flow priority valve (3) which located in the hydraulic control valve assembly (4) divides the oil into two direction. One is the control flow to power steering (constantly 7 L/min., 1.8 U.S.gals./min., 1.5 Imp.gals./min.), and the other is excessive flow to control valve of implement lift control.

By operating the power steering body, the required amount of oil is fed to the steering cylinder (2).

2. STEERING CONTROLLER

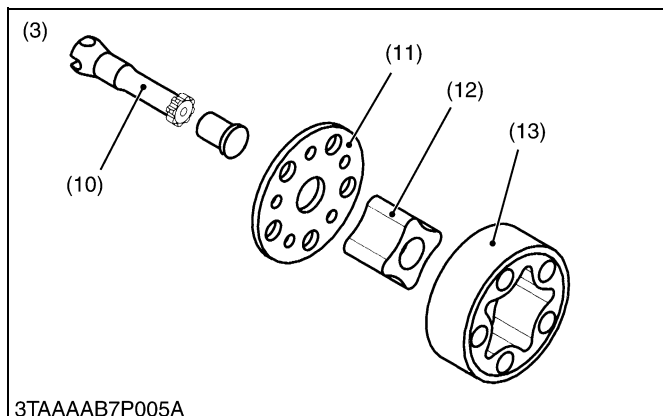
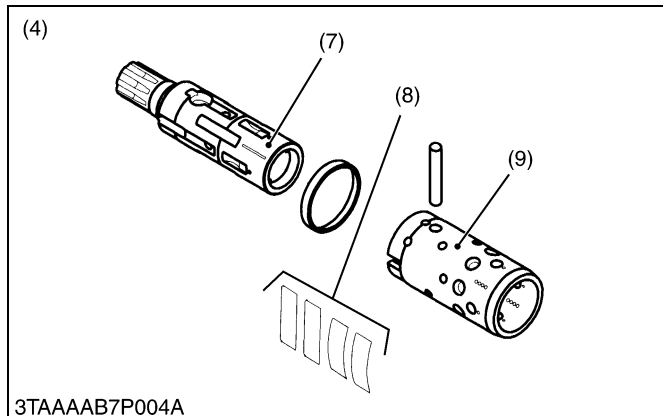
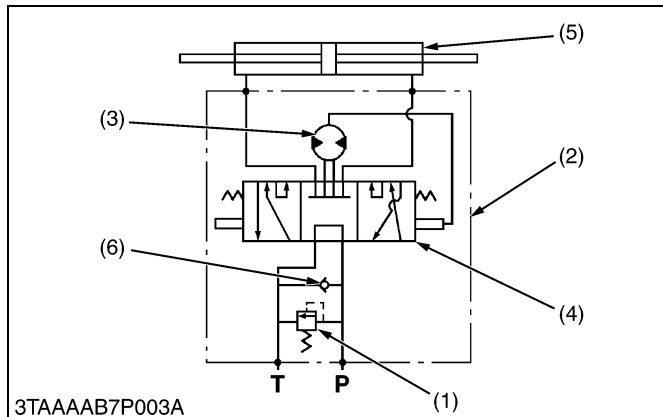
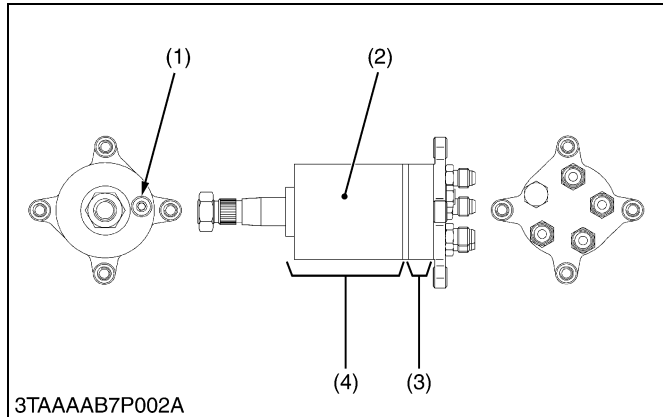

The steering controller consists of a control valve (4) and a metering device (3).

■ Control Valve

The control valve is a rotating spool type.

When the steering wheel is turned, the position of the spool (7) and sleeve (9) is kept neutral by the centering spring (8). This causes the forming of a "Neutral" oil circuit.

When the steering wheel is turned either clockwise or counterclockwise, the position of the spool and sleeve changes in relation to the centering spring. This allows the forming of a "Right Turning" or "Left Turning" oil circuit. At the same time, the gear pump (Metering device) rotates with the spool and sends the oil to the cylinder corresponding to the rotation of the steering wheel.

■ Metering Device

An oil, sent from the hydraulic pump to the steering cylinder, passes through the metering device (3).

Namely, when the rotor is driven, two chambers suck in oil due to volumetric change in the pump chambers formed between the rotor (12) and the stator (13), while oil is discharged from other two chambers. On the other hand, rotation of the steering wheel is directly transmitted to the rotor through the spool (7), drive shaft (10), etc.

Accordingly, the metering device serves to supply the steering cylinder with oil, amount of which corresponds to the rotation of the steering wheel. The wheels are thus turned by the angle corresponding to the rotation of the steering wheel.

When the engine stops or the hydraulic pump malfunctions, the metering device functions as a manual trochoid pump, which makes manual steering possible.

■ Relief Valve

The relief valve (1) is located in the steering controller. It controls the maximum pressure of the power steering system.

Its setting pressure is as follows.

8.33 to 8.83 MPa

85 to 90 kgf/cm²

1209 to 1280 psi

- | | |
|-------------------------|------------------------|
| (1) Relief Valve | (10) Drive Shaft |
| (2) Steering Controller | (11) Distributor Plate |
| (3) Metering Device | (12) Rotor |
| (4) Control Valve | (13) Stator |
| (5) Steering Cylinder | |
| (6) Check Valve | |
| (7) Spool | |
| (8) Centering Spring | |
| (9) Sleeve | |

P : P Port (From flow priority valve)

T : T Port (To PTO clutch valve and HST circuit)

W1012783

3. STEERING CYLINDER

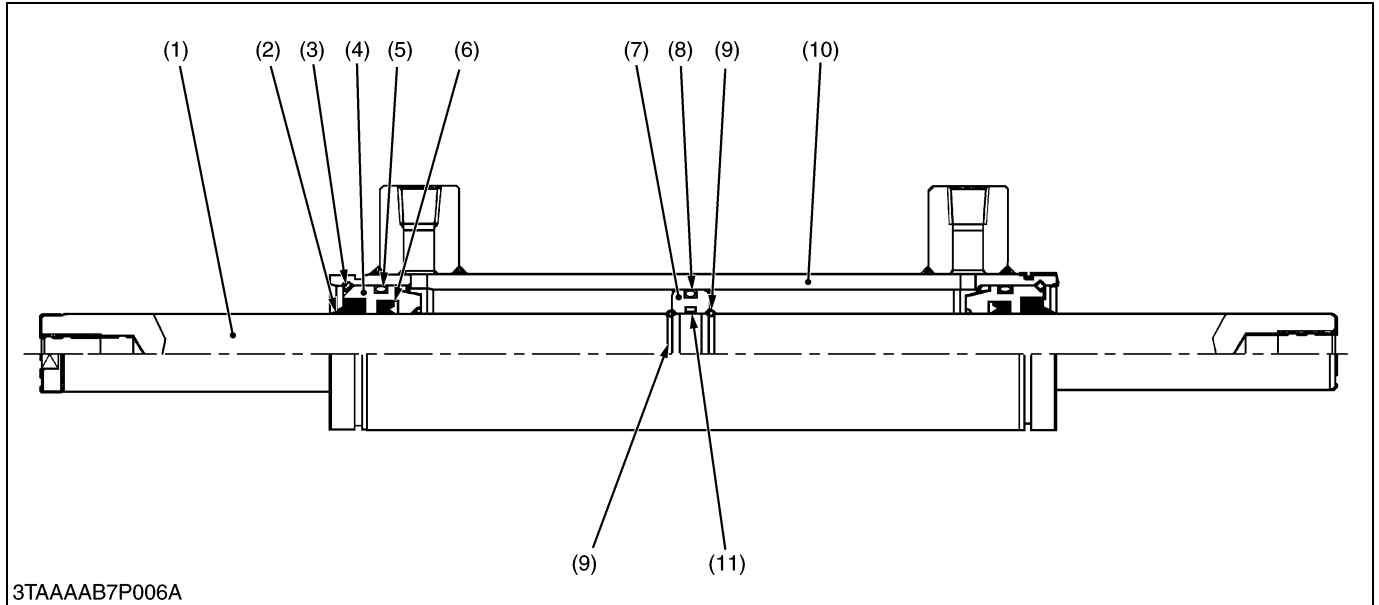

3TAAAAB7P006A

- | | | | |
|------------------------|---------------|------------------------|--------------------|
| (1) Rod | (4) Guide | (7) Center Piston | (10) Cylinder Tube |
| (2) Wiper Ring | (5) O-ring | (8) Piston O-ring | (11) Rod O-ring |
| (3) Internal Snap Ring | (6) Seal Ring | (9) External Snap Ring | |

The steering cylinder is single piston both rod double-acting type. This steering cylinder is installed parallel to the front axle and connected to tie-rods.

The tie-rods connected to both knuckle arm guarantees equal steering movement to both front wheels.

The steering cylinder provide force in both directions. Depending upon direction the steering wheel is turned pressure oil enters at one end of the cylinder to extend, or the other end to retract it, thereby turning front wheel of the tractor.

SERVICING

CONTENTS

1. TROUBLESHOOTING	4-S1
2. SERVICING SPECIFICATIONS	4-S2
3. TIGHTENING TORQUES	4-S3
4. CHECKING, DISASSEMBLING AND SERVICING.....	4-S4
[1] CHECKING	4-S4
(1) Relief Valve.....	4-S4
[2] DISASSEMBLING AND ASSEMBLING.....	4-S4
(1) Separating Power Steering Controller	4-S4
(2) Separating Power Steering Cylinder.....	4-S6
(3) Disassembling Power Steering Cylinder.....	4-S7
[3] SERVICING	4-S8

1. TROUBLESHOOTING

Symptom	Probable Cause	Solution	Reference Page
Cannot Be Steered	<ul style="list-style-type: none"> Steering controller malfunctioning Pipe broken 	Replace Replace	4-S5 4-S5
Hard Steering	<ul style="list-style-type: none"> Power steering oil improper Hydraulic pump malfunctioning Flow priority valve malfunctioning Steering controller malfunctioning 	Change with specified oil Replace Repair or replace Replace	G-20 5-S12 5-S10 4-S5
Steering Force Fluctuates	<ul style="list-style-type: none"> Steering controller malfunctioning Flow priority valve malfunctioning Air sucked in pump due to lack of oil Air sucked in pump from suction circuit 	Replace Replace Replenish Repair	4-S5 5-S10 G-13 –
Steering Wheel Turns Spontaneously When Released	<ul style="list-style-type: none"> Steering controller malfunctioning 	Replace	4-S5
Front Wheels Wander to Right and Left	<ul style="list-style-type: none"> Steering controller malfunctioning Air sucked in pump due to lack of oil Air sucked in pump from suction circuit Insufficient bleeding Cylinder malfunctioning Improper toe-in adjustment Tire pressure uneven 	Replace Replenish Repair Bleed Repair or replace Adjust Inflate	4-S5 G-13 – – 4-S7 3-S4 G-35
Wheels Are Turned to a Direction Opposite to Steering Direction	<ul style="list-style-type: none"> Cylinder piping connected in reverse 	Repair	4-S6
Steering Wheel Turns Idle in Manual Steering	<ul style="list-style-type: none"> Insufficient bleeding Air sucked in due to lack of oil 	Bleed Replenish	– G-13
Noise	<ul style="list-style-type: none"> Air sucked in pump due to lack of oil Air sucked in pump from suction circuit Pipe deformed 	Replenish Repair Replace	G-13 – –
Oil Temperature Increases Rapidly	<ul style="list-style-type: none"> Steering controller (relief valve) malfunctioning 	Replace	4-S5

W1014322

2. SERVICING SPECIFICATIONS

POWER STEERING BODY

Item		Factory Specification	Allowable Limit
Relief Valve	Operating Pressure	9.30 to 9.79 MPa 94.8 to 99.8 kgf/cm ² 1348 to 1419 psi	–

W1013874

STEERING CYLINDER

Steering Cylinder	I.D.	40.000 to 40.062 mm 1.57480 to 1.57724 in.	40.100 mm 1.57874 in.
Piston Rod to Guide	Clearance	0.020 to 0.070 mm 0.00079 to 0.00276 in.	0.200 mm 0.00787 in.

W1013973

3. TIGHTENING TORQUES

Tightening torques of screws, bolts and nuts on the table below are especially specified.
(For general use screws, bolts and nuts : See page G-8.)

Item	N·m	kgf·m	ft-lbs
Steering wheel mounting nut	20 to 25	2.0 to 2.6	14.8 to 18.4
Power steering hose mounting nut	28.4 to 30.0	2.9 to 3.1	20.9 to 22.1
Under cover mounting bolt and nut	7.8 to 8.8	0.8 to 0.9	5.8 to 6.5
Tie-rod slotted nut	17.7 to 34.3	1.8 to 3.5	13.0 to 25.3
Tie-rod screw	74 to 84	7.5 to 8.6	54.6 to 61.9

W1012736

4. CHECKING, DISASSEMBLING AND SERVICING

[1] CHECKING

(1) Relief Valve

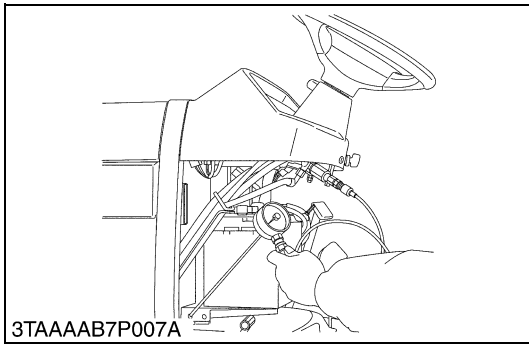

Relief Valve Operating Pressure

1. Disconnect the power steering hose L (or R) from steering controller, and set a pressure gauge and cable.

(Reference)

- Hose and adaptor size : 9/16-18UNF, 37 ° flare
2. Start the engine and set at maximum speed.
 3. Fully turn the steering wheel to the left (or right) to check the feeling which the steering wheel lightly locks. Read the relief valve operating pressure when the steering wheel to the above-mentioned lock position by operation force at approximately 9.8 N (1 kgf, 2.2 lbs) of outer.

■ **NOTE**

- **After set a pressure gauge, be sure to bleed air.**
- **Note that the pressure value changes by the pump action of the power steering controller when the steering operation is continued after the steering wheel is lightly locked and accurate relief valve pressure cannot be measured.**

Relief valve operating pressure	Factory spec.	9.30 to 9.79 MPa 94.8 to 99.8 kgf/cm ² 1348 to 1419 psi
---------------------------------	---------------	--

W1011481

[2] DISASSEMBLING AND ASSEMBLING

(1) Separating Power Steering Controller

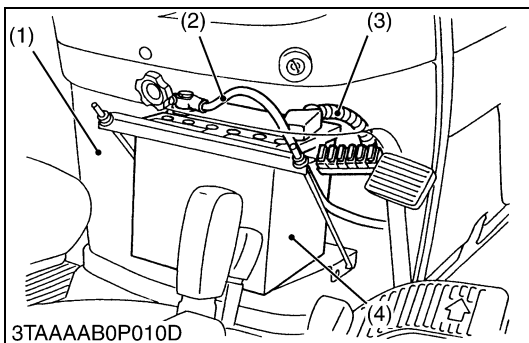

Battery

⚠ CAUTION

- **When disconnecting the battery cables, disconnect the negative cable from the battery first. When connecting, connect the positive cable to the battery first.**

1. Remove the under panel (1).
2. Disconnect the negative cable (2) from the battery.
3. Disconnect the positive cable (3) from the battery and remove the battery (4).

- | | |
|--------------------|--------------------|
| (1) Under Panel | (3) Positive Cable |
| (2) Negative Cable | (4) Battery |

W1011659

Steering Wheel

1. Remove the steering wheel cap.
2. Remove the steering wheel mounting nut and remove the steering wheel.

(When reassembling)

Tightening torque	Steering wheel mounting nut	20 to 25 N·m 2.0 to 2.6 kgf·m 14.8 to 18.4 ft-lbs
-------------------	-----------------------------	---

W1011793

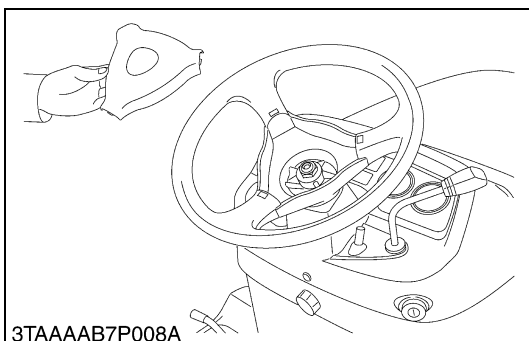

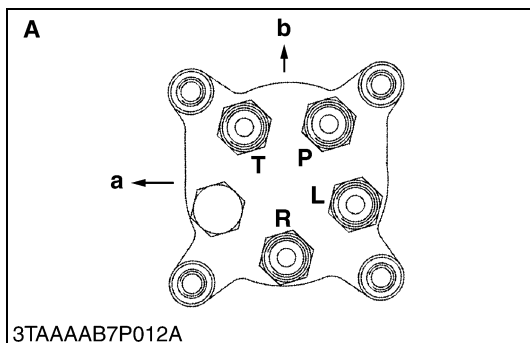
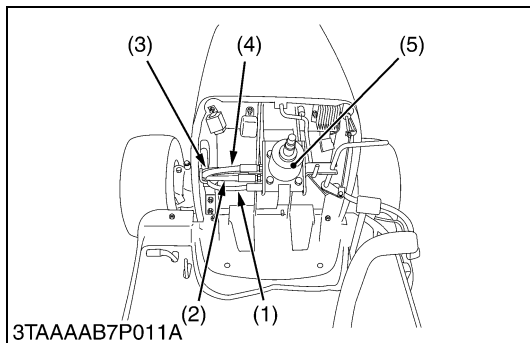
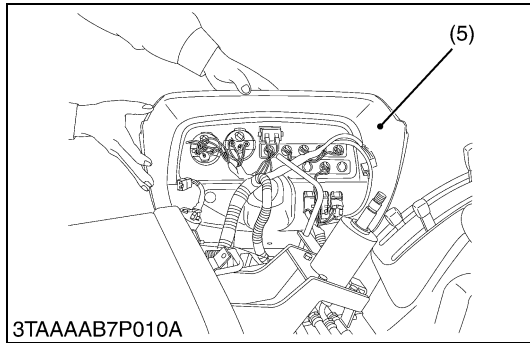
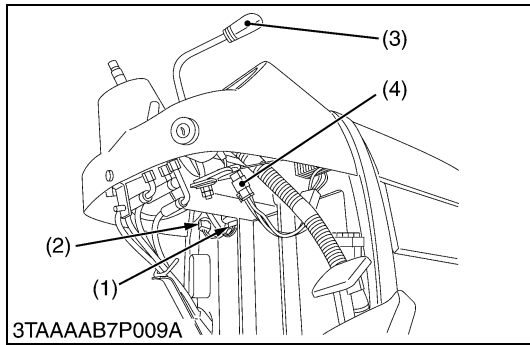

Meter Panel

1. Remove the hand accelerator lever grip (2).
2. Disconnect the connector for main switch (4), timer relay (2) (BX1800 only) and flasher unit (1).
3. Remove the panel mounting screws and dismount the meter panel (5).
4. Disconnect the all connectors from panel and remove the meter panel (5).

- (1) Connector for Flasher Unit
- (2) Connector for Timer Relay (BX1800 Only)
- (3) Accelerator Lever Grip
- (4) Connector for Main Switch
- (5) Meter Panel

W1011901

Steering Controller

1. Disconnect the power steering hoses (1), (2), (3), (4).
2. Remove the steering controller mounting screws and remove the steering controller (5).

(When reassembling)

- Be sure to connect the power steering hoses to their original position, and tighten them to the specified torque.

Tightening torque	Power steering hose mounting nut	28.4 to 30.0 N·m 2.9 to 3.1 kgf·m 20.9 to 22.1 ft·lbs
-------------------	----------------------------------	---

- (1) Cylinder Hose RH
- (2) Cylinder Hose LH
- (3) Return Hose
- (4) Delivery Hose
- (5) Steering Controller

- A : Bottom View**
- P : Pump Port**
(Connect to Delivery Hose)
- T : Tank Port**
(Connect to Return Hose)
- L : L Port**
(Connect to Cylinder LH Hose)
- R : R Port**
(Connect to Cylinder RH Hose)
- a : Right**
- b : Front**

W1012133

(2) Separating Power Steering Cylinder

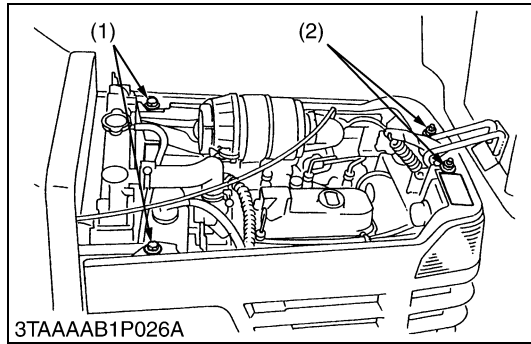

Under Cover

1. Remove the under cover mounting boles (1), loosen the mounting nuts (2) and pull forward to remove the under cover (3).

(When reassembling)

Tightening torque	Under cover mounting bolt and nut	7.8 to 8.8 N·m 0.8 to 0.9 kgf·m 5.8 to 6.5 ft-lbs
-------------------	-----------------------------------	---

- (1) Under Cover Mounting Bolt (3) Under Cover
(2) Under Cover Mounting Nut

W1012337

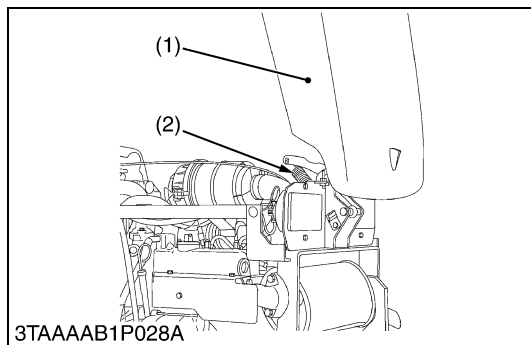
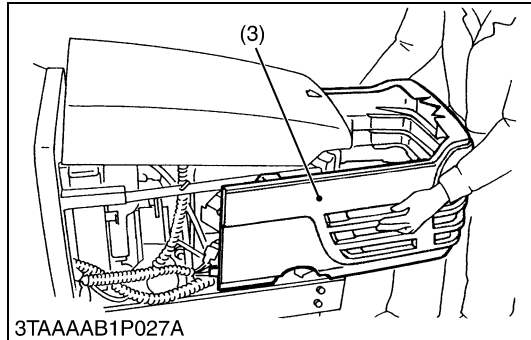

Bonnet

1. Remove the spring (2).
2. Remove the bonnet mounting bolt and nut, and remove the bonnet (1).

- (1) Bonnet (2) Spring

W1012573

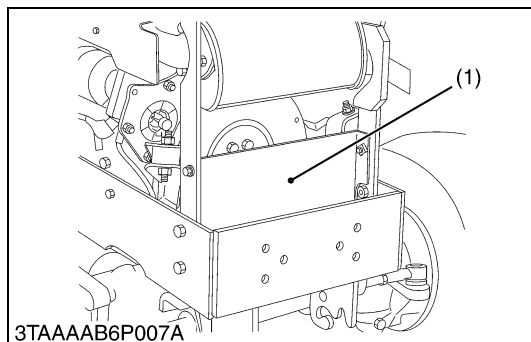

Power Steering Cylinder

1. Remove the flywheel cover (1).
2. Disconnect the power steering cylinder hoses (3), (4).
3. Remove the cotter pin and remove the slotted nut for tie-rod (2).
4. Remove the power steering cylinder mounting screws and remove the power steering cylinder with tie-rod.

(When reassembling)

■ NOTE

- **Tighten the slotted nut to 17.7 N·m (1.8 kgf·m, 13 ft-lbs). If the slot and pin hole do not meet, tighten the nut until they do meet, and install cotter pin.**
- **Be sure to split the cotter pin like an anchor.**

Tightening torque	Power steering cylinder hose	28.4 to 30.0 N·m 2.9 to 3.1 kgf·m 20.9 to 22.1 ft-lbs
	Tie-rod slotted nut	17.7 to 34.3 N·m 1.8 to 3.5 kgf·m 13.0 to 25.3 ft-lbs

- (1) Flywheel Cover (3) Cylinder Hose RH
(2) Tie-rod (4) Cylinder Hose LH

W1012658

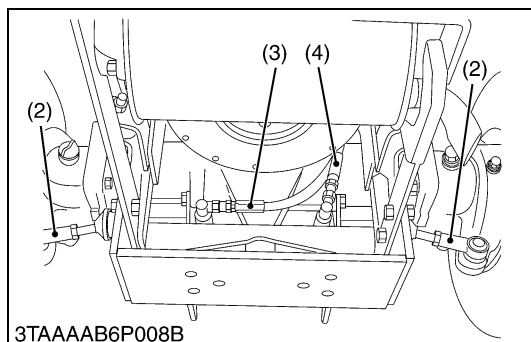

(3) Disassembling Power Steering Cylinder

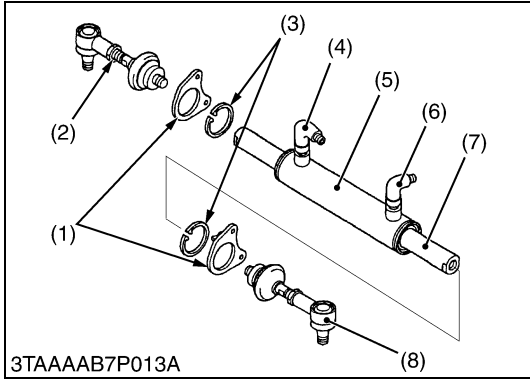

Adaptor and Tie-rod

1. Remove the cylinder hose adaptors (4), (6).
2. Remove the tie-rods (2), (8) from piston rod (7).
3. Remove the cylinder holder (1) and internal snap ring (3).

(When reassembling)

- Be sure to install the hose adaptors (4), (6) as shown figure left.
- After reassembling the tie-rod, be sure to adjust the toe-in. (Refer to 3-S4.)

Tightening torque	Tie-rod screw	74 to 84 N·m 7.5 to 8.6 kgf·m 54.6 to 61.9 ft·lbs
-------------------	---------------	---

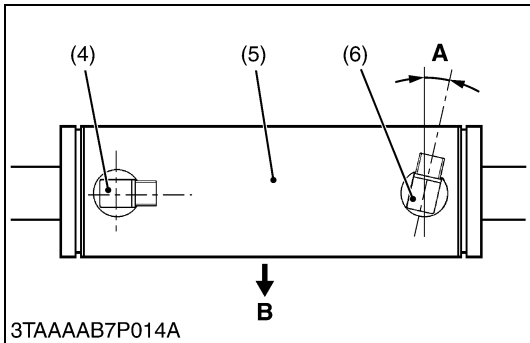

- | | |
|------------------------|-----------------------------|
| (1) Cylinder Holder | (7) Piston Rod |
| (2) Tie-rod RH | (8) Tie-rod LH |
| (3) Internal Snap Ring | |
| (4) Hose Adaptor RH | A : 0.26 rad. (15 °) |
| (5) Cylinder | B : Front |
| (6) Hose Adaptor LH | |

W1012941

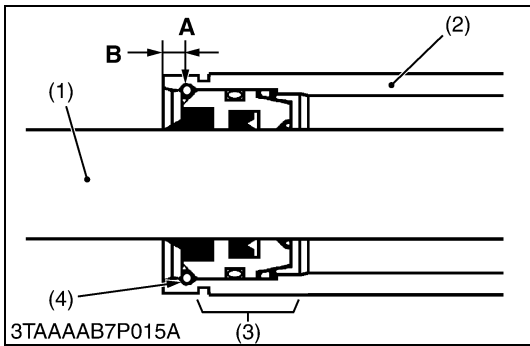

Steering Cylinder

1. Carefully clamp the cylinder in a vise.
2. Push one of the guide assembly (3) to inside of cylinder tube (2).
3. Drill a hole (2.5 mm dia., 0.1 in. dia.) on the cylinder tube (2) just over the snap ring (4) as shown figure left.
4. Take a little screwdriver and lift off the snap ring (4) from its groove. Simultaneous support this action by pushing from the outside of the cylinder tube with another little screwdriver or another tool.
5. Push out the piston rod assembly (9) and take off the guide assembly (3).

(When reassembling)

NOTE

- **Seals must be exchanged after disassembling.**
- Apply transmission fluid to the exchanged seals.
- Enter the piston rod and block the guide assemblies with the snap rings.

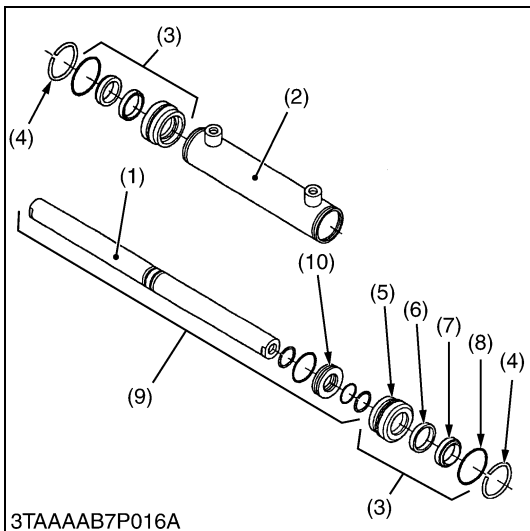

- | | |
|--------------------|--------------------------------|
| (1) Piston Rod | (8) O-ring |
| (2) Cylinder Tube | (9) Piston Rod Assembly |
| (3) Guide Assembly | (10) Center Piston |
| (4) Snap Ring | |
| (5) Guide | A : Drill a Hole |
| (6) Seal Ring | B : 5.25 mm (0.267 in.) |
| (7) Wiper Ring | |

W1013441

[3] SERVICING

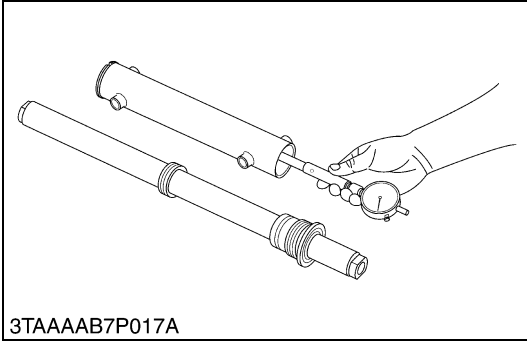

Steering Cylinder I.D.

1. Measure the steering cylinder I.D. with a cylinder gauge.
2. If the cylinder I.D. exceed the allowable limit, replace the cylinder barrel.

Steering cylinder I.D.	Factory spec.	40.000 to 40.062 mm 1.57480 to 1.57724 in.
	Allowable limit	40.100 mm 1.57874 in.

W1013872

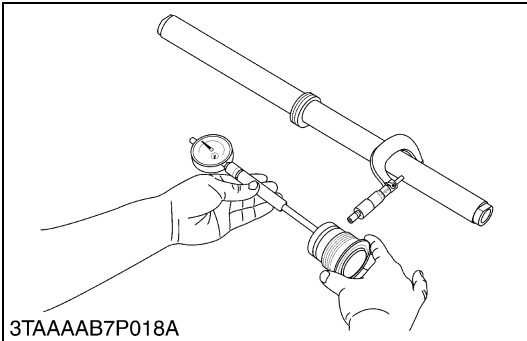

Clearance between Rod and Guide

1. Measure the rod guide I.D. with a cylinder gauge.
2. Measure the rod O.D. with an outside micrometer, and calculate the clearance.
3. If the clearance exceeds the allowable limit, replace as a unit.

Clearance between rod and guide	Factory spec.	0.020 to 0.070 mm 0.00079 to 0.00276 in.
	Allowable limit	0.200 mm 0.00787 in.

W1013777

5 HYDRAULIC SYSTEM

MECHANISM

CONTENTS

1. HYDRAULIC CIRCUIT	5-M1
2. HYDRAULIC PUMP	5-M2
3. HYDRAULIC CONTROL VALVE	5-M3
4. FLOW PRIORITY VALVE	5-M4
5. RELIEF VALVE	5-M5
6. HYDRAULIC CYLINDER	5-M6
7. HYDRAULIC BLOCK TYPE OUTLET	5-M7
8. MOWER LINKAGE	5-M8

1. HYDRAULIC CIRCUIT

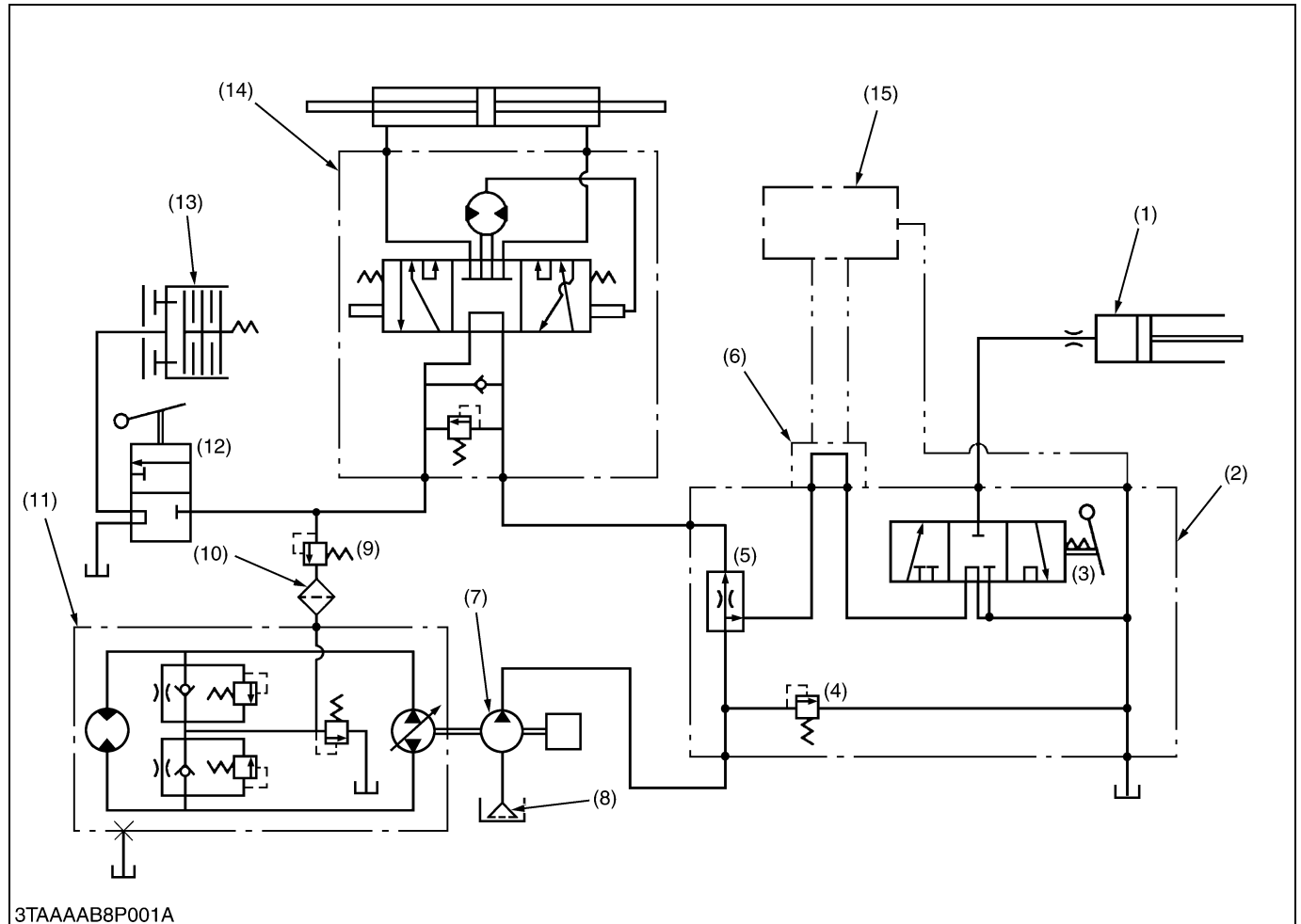

- | | | | |
|--------------------------------------|-------------------------|-------------------------------|---------------------------------|
| (1) Hydraulic Cylinder | (4) Relief Valve | (8) Oil Strainer | (12) PTO Clutch Valve |
| (2) Hydraulic Control Valve Assembly | (5) Flow Priority Valve | (9) PTO Relief Valve | (13) PTO Clutch |
| (3) Control Valve | (7) Hydraulic Pump | (10) Oil Filter | (14) Power Steering Controller |
| | | (11) Hydrostatic Transmission | (15) Front Loader (If equipped) |

The hydraulic system of this tractor is composed of a hydraulic pump, hydraulic block type outlet, control valve, hydraulic cylinder and other components.

This system has the following functions.

1. Oil is supplied by hydraulic pump which is driven by pump drive shaft in the transmission case. As the pump drive shaft is connected to the propeller shaft, hydraulic pump starts running when engine is started.
2. The hydraulic pump forces out the oil to control valve for 3 point hitch system, power steering controller, PTO clutch valve and hydrostatic transmission after dividing oil flow by flow priority valve.
3. Hydraulic power take off from the hydraulic block type outlet to operate the implements such as a front loader and etc.

2. HYDRAULIC PUMP

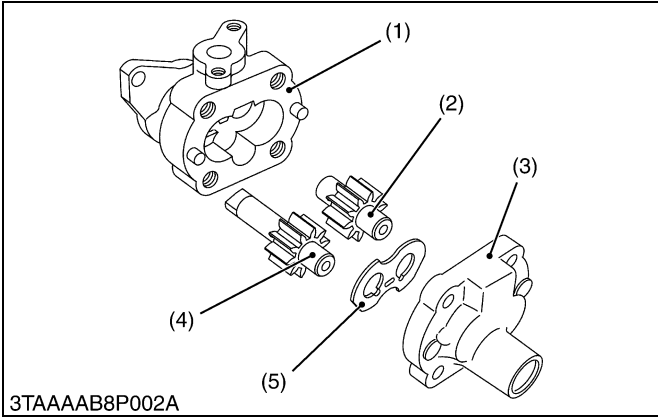

The hydraulic pump is composed of the casing (1), cover (3), side plate (5), and two spur gears (drive gear (4) and driven gear (2)) that are in mesh.

Hydraulic pump is driven by the pump drive shaft in the transmission case.

Maximum displacement is as follows.

Displacement	Engine speed	Condition
21.0 L/min. 5.5 U.S.gals./min. 4.6 Imp.gals./min.	At 3200 min ⁻¹ (rpm)	at no load

- (1) Casing
- (2) Driven Gear
- (3) Cover
- (4) Drive Gear
- (5) Side Plate

W1013860

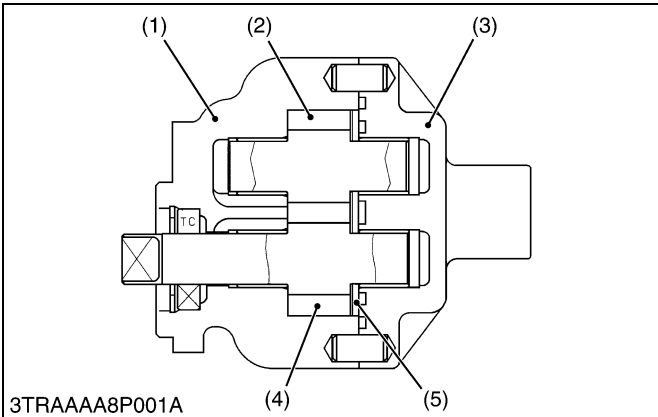

3. HYDRAULIC CONTROL VALVE

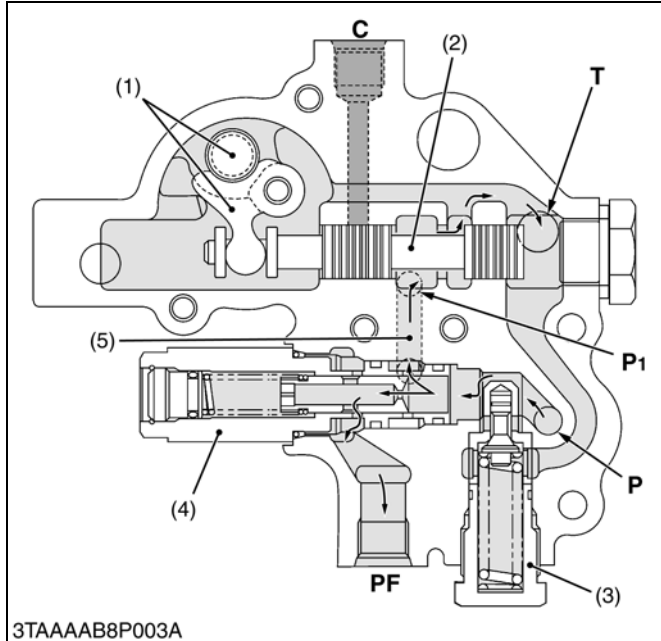

Hydraulic control valve assembly is composed of control valve, flow priority valve (4) and relief valve (3). Oil from hydraulic pump is divided by flow priority valve (4) and forced into the control valve through passage (5) of hydraulic block type outlet. The spool (2) is moved by control arm (1) which is connected to hydraulic lever and oil from pump is changed flow direction by spool movement.

■ **Neutral**

Oil forced into the control valve through **P1** port and returns to the transmission case through **T** port.

Also, **C** port is closed by spool (2), oil in the hydraulic cylinder does not flow to the transmission case.

Thus, the implement remains at its fixed position.

- | | |
|-------------------------------|---|
| (1) Control Arm | P, P1 : Pump Port |
| (2) Spool (for Control Valve) | C : Cylinder Port |
| (3) Relief Valve | T : Tank Port |
| (4) Flow Priority Valve | PF : PF Port (to power steering circuit) |
| (5) Passage | |

W1013049

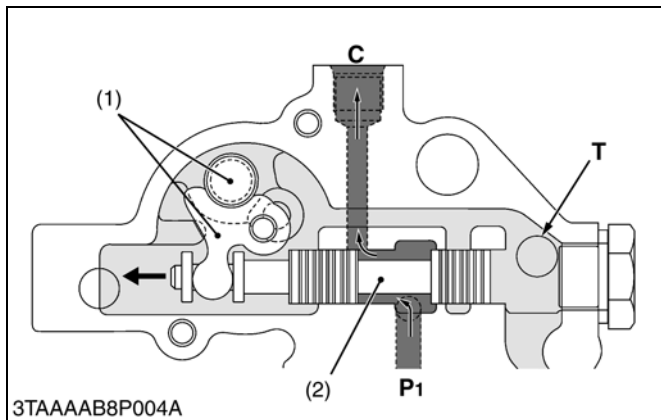

■ **Lift**

When the control lever is set to the “**LIFT**” position, the spool (2) is moved to the left.

The oil forced into the control valve through **P1** port flows to **C** port.

The oil pushes and flow into the hydraulic cylinder through the **C** port to lift the implement.

- | | |
|-----------------|--------------------------|
| (1) Control Arm | P1 : Pump Port |
| (2) Spool | C : Cylinder Port |
| | T : Tank Port |

W1013268

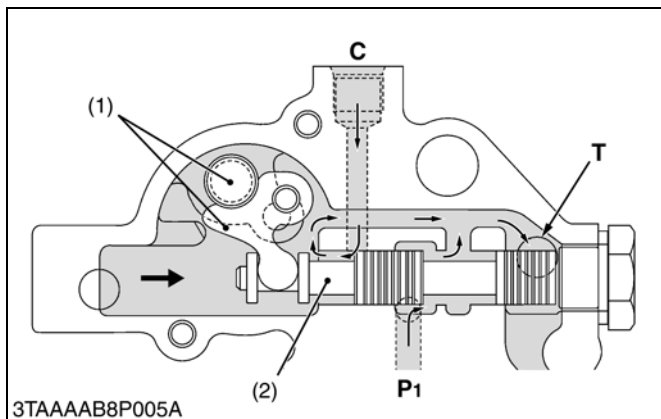

■ **Down**

When the control lever is moved to “**Down**” position, the spool (2) is moved to the right.

Oil in the hydraulic cylinder is forced out to the transmission case through gap of spool and **T** port by the weight of the implement, causing the implement to lower.

Oil forced into the control valve through the **P1** port and returns to the transmission case through the **T** port.

- | | |
|-----------------|--------------------------|
| (1) Control Arm | P1 : Pump Port |
| (2) Spool | C : Cylinder Port |
| | T : Tank Port |

W1013211

4. FLOW PRIORITY VALVE

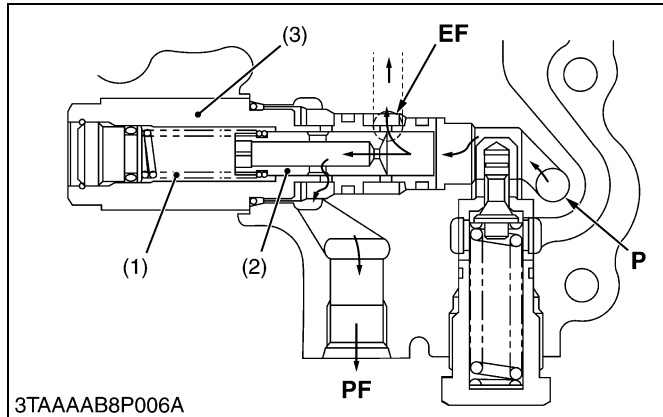

The flow priority valve is a flow divider that divides the flow from single hydraulic source (hydraulic pump) to actuates two circuits simultaneously.

This valve feeds fixedly controlled flow (7 L/min., 1.8 U.S.gals./min., 1.5 Imp.gals./min.) to the **PF** port with priority and excessive flow to the **EF** port.

- (1) Spring
- (2) Spool
- (3) Valve Body

EF : EF Port (to 3 point hitch control circuit)
PF : PF Port (to power steering PTO clutch and HST circuit)
P : Pump Port

W1013500

5. RELIEF VALVE

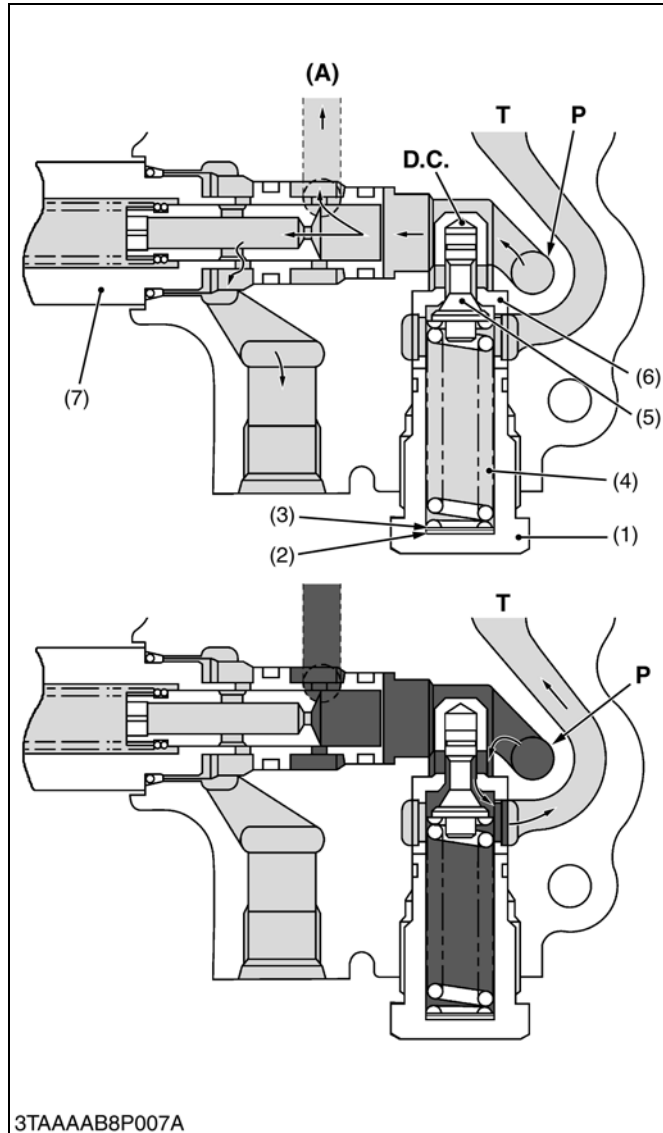

The implement control system circuit has a relief valve to restrict the maximum pressure in the circuit. The relief valve is located in the hydraulic control valve assembly.

The relief valve is of the guide piston type with damping effect.

Among direct acting relief valves, this type is suited to higher pressure and has large capacity. Furthermore, this type is free from unstable operation, such as chattering, which occurs often in direct acting relief valves.

As shown in the figure, the guide is attached to the poppet (5) and a valve chamber **D.C.** (called the damping chamber) is formed at the top of the guide piston. The inlet of the valve leads to the chamber via a clearance between the sliding portion of the guide and the seat (6), minimizing valve vibration with the damping effect of the chamber.

When the oil pressure in the circuit is lower than the setting pressure of the relief valve, the relief valve is not operated and the oil fed to the relief valve from the hydraulic pump flows into the implement control valve.

As the oil pressure in the circuit increases, so does the pressure in the damping chamber **D.C.**. When the pressure rises above the valve setting and overcomes the spring force, the valve opens. Oil then flows out to the transmission case through **T** port, preventing any further rise in pressure. The valve closes again when enough oil is released to drop pressure below the valve setting.

(Reference)

- Relief valve setting pressure : 12.3 to 12.7 MPa
125 to 130 kgf/cm²
1778 to 1849 psi
- Engine speed : Maximum
- Oil temperature : 40 to 50 °C
104 to 122 °F

- (1) Plug
- (2) Washer
- (3) Shim
- (4) Spring
- (5) Poppet
- (6) Seat
- (7) Flow Priority Valve

- D.C.** : Damping Chamber
- P** : Pump Port
- T** : Tank Port
- (A)** To Hydraulic Control Valve

W1013612

6. HYDRAULIC CYLINDER

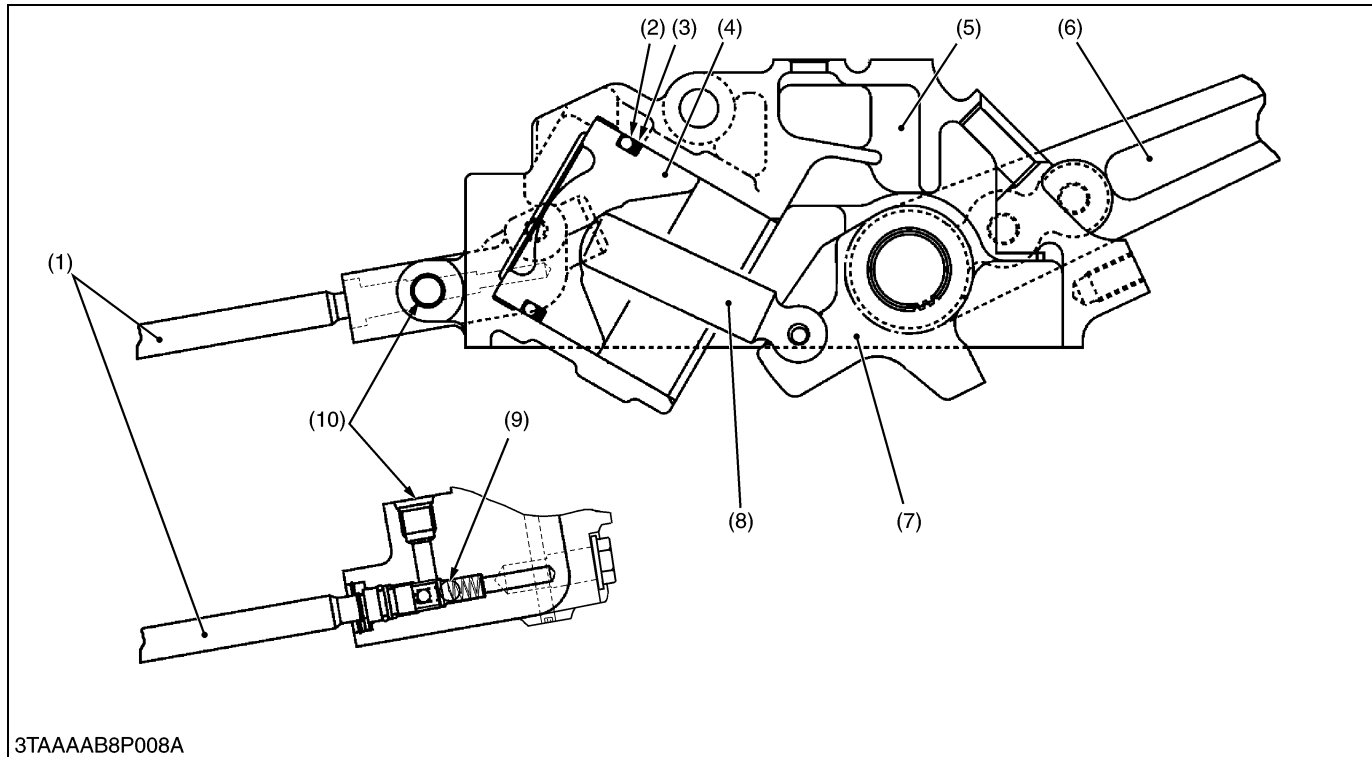

- | | | | |
|------------------------------------|------------------------|-------------------|---|
| (1) Lowering Speed Adjusting Shaft | (3) Back-up Ring | (6) Lift Arm | (9) Ball |
| (2) O-ring | (4) Piston | (7) Hydraulic Arm | (10) Cylinder Port (Connected to Control Valve) |
| | (5) Hydraulic Cylinder | (8) Hydraulic Rod | |

The main components of the hydraulic cylinder are shown in the figure above.

While the lift arm (6) is rising, oil from the hydraulic pump flows into the hydraulic cylinder through the hydraulic control valve and cylinder port (10). Then oil pushes out the piston (4).

While the lift arm (6) is lowering, oil in the hydraulic cylinder is discharged to the transmission case through the hydraulic control valve by the weight of the implement. At this time, the lowering speed of the implement can be controlled by the ball (9) attached to the hydraulic cylinder (5). Turning the lowering speed adjusting knob clockwise decreases the lowering speed, and counterclockwise increases lowering speed. When the lowering speed adjusting valve is completely closed, the lift arm (6) is held at its position since oil in the hydraulic cylinder is sealed between the piston (4) and ball (9).

7. HYDRAULIC BLOCK TYPE OUTLET

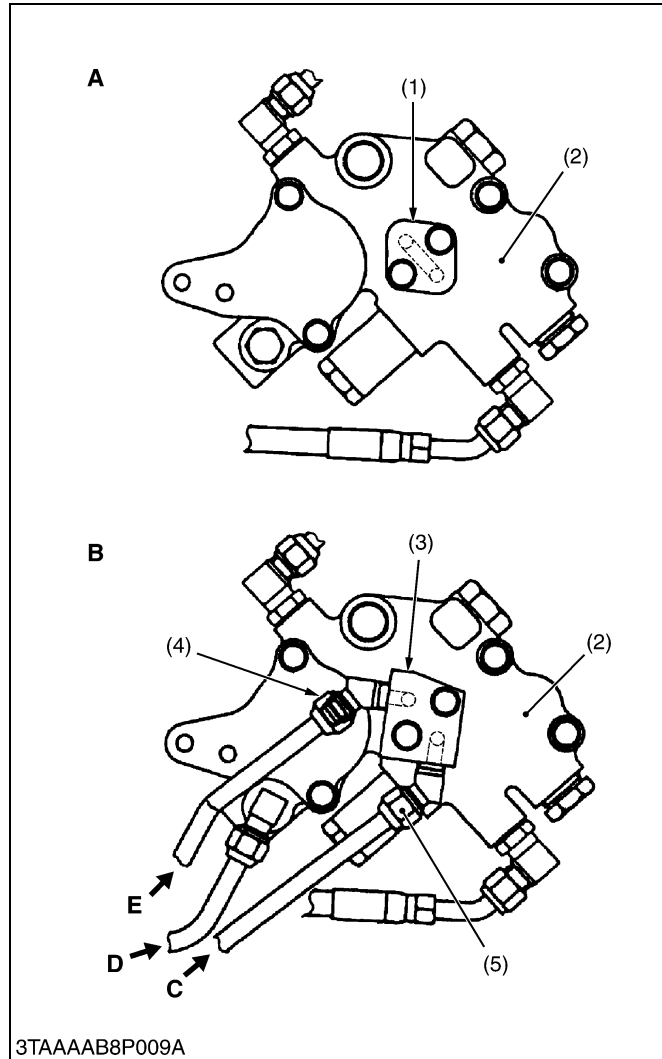

The hydraulic block type outlet is located on the control valve assembly.

This hydraulic block type outlet is provided to take power out from the tractor to operate the hydraulic cylinders on the implement, such as front end loader, front blade and so on.

- (1) Block Cover
- (2) Hydraulic Control Valve Assembly
- (3) Block Outlet Cover (Option)
- (4) Inlet
- (5) Outlet

A : When implement is not attached

B : When implement is attached

C : To implement (Outlet)
 Max. flow 14 L/min.
 (3.7 U.S.gals./min.,
 3.1 Imp.gals./min.)

D : Return Port

E : From implement (Inlet)

W1014064

8. MOWER LINKAGE

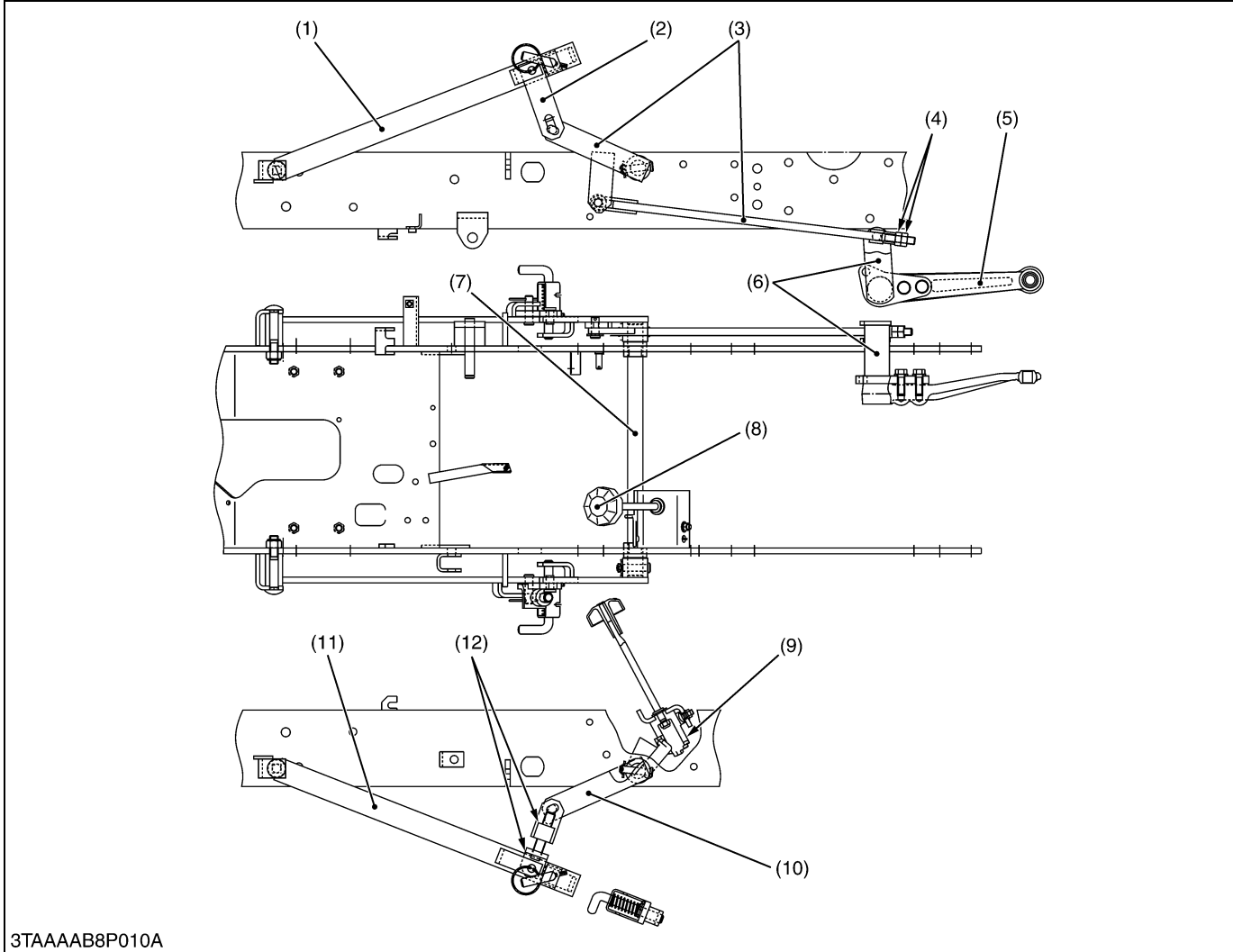

3TAAAAB8P010A

- | | | | |
|------------------------|------------------------|-----------------------------------|-------------------------|
| (1) Mower Rear Link RH | (4) Link Adjusting Nut | (7) Lift Link Shaft | (10) Lift Link Rear LH |
| (2) Lift Link RH | (5) Lift Arm RH | (8) Cutting Height Adjusting Dial | (11) Mower Rear Link LH |
| (3) Lift Link Rear RH | (6) Mower Lift Arm | (9) Adjusting Cam | (12) Lift Link LH |

The mower rear link (1), (11) and lift arm RH (5) are linked with lift link (2), (12), lift link rear (3), (10) lift link shaft (7) and mower lift arm (6).

As the hydraulic control lever moves to up position, lift arm (5) is raised and mower lift arm (6) is rotated to pull the lift links to the rearward. As a result, mower rear link (1), (11) are lifted.

The cutting height adjusting dial (8) is adjusts cutting height of mower by rotating the adjusting cam (9). The position of mower rear link (1), (11) are adjusted by changing the rod of lift link rear RH (3).

SERVICING

CONTENTS

1. TROUBLESHOOTING	5-S1
2. SERVICING SPECIFICATIONS	5-S2
3. TIGHTENING TORQUES	5-S3
4. CHECKING, DISASSEMBLING AND SERVICING.....	5-S4
[1] HYDRAULIC CONTROL VALVE, PUMP AND CYLINDER	5-S4
(1) Checking and Adjusting	5-S4
(2) Disassembling and Assembling	5-S5
(3) Servicing	5-S12
[2] MOWER LIFT LINKAGE	5-S15

1. TROUBLESHOOTING

Symptom	Probable Cause	Solution	Reference Page
Implement Does Not Rise (No Noise)	<ul style="list-style-type: none"> Control valve broken Control valve improperly assembled Relief valve spring damaged Spool sticks Piston O-ring or cylinder damaged 	Replace Repair Replace Repair Replace	5-S10 5-S10 5-S10 5-S10 5-S12
	(Noise)	<ul style="list-style-type: none"> Oil filter cartridge clogged Suction pipe loosen or broken Suction pipe connecting hose loosen or broken Suction pipe O-ring broken Insufficient transmission oil Relief valve setting pressure too low Hydraulic pump broken 	Replace Repair or replace Repair or replace Replace Refill Adjust or replace Replace
Implement Does Not Reach Maximum Height	<ul style="list-style-type: none"> Feedback rod improperly adjusted 	Adjust	5-S5
Implement Does Not Lower	<ul style="list-style-type: none"> Control valve malfunctioning 	Repair or replace	5-S10
Implement Drops by Its Weight	<ul style="list-style-type: none"> Hydraulic cylinder worn or damaged Piston O-ring worn or damaged Control valve malfunctioning 	Replace Replace Replace	– 5-S12 5-S10

W1014322

2. SERVICING SPECIFICATIONS

Item		Factory Specification	Allowable Limit
[Hydraulic Pump] Gear to Casing	Clearance	–	0.15 mm 0.0059 in.
	Gear Shaft to Bushing	0.020 to 0.091 mm 0.0008 to 0.0036 in.	0.12 mm 0.0047 in.
	Gear Shaft	O.D. 14.970 to 14.980 mm 0.5894 to 0.5898 in.	–
	Bushing	I.D. 15.000 to 15.061 mm 0.5906 to 0.5930 in.	–
	Side Plate	Thickness 2.48 to 2.50 mm 0.0976 to 0.0984 in.	2.40 mm 0.0945 in.
Relief Valve	Setting Pressure	12.3 to 12.7 MPa 125 to 135 kgf/cm ² 1778 to 1849 psi	–
Lift Arm	Free Play	5 to 10 mm 0.20 to 0.40 in.	–
Hydraulic Cylinder	I.D.	80.05 to 80.15 mm 3.1516 to 3.1555 in.	80.2 mm 3.1575 in.

W1013874

3. TIGHTENING TORQUES

Tightening torques of screws, bolts and nuts on the table below are especially specified.
 (For general use screws, bolts and nuts : See page G-8.)

Item	N·m	kgf·m	ft-lbs
ROPS mounting nut	124 to 147	12.6 to 15.0	91 to 108
Rear wheel mounting screw	108.5 to 130.2	11.1 to 13.2	80 to 96
Fuel tank stay mounting bolt and nut	48.1 to 55.9	4.9 to 5.7	35.4 to 41.2
Stopper plate mounting bolt and nut	77.5 to 90.2	7.9 to 9.2	57.1 to 66.5
PTO cover RH and LH mounting bolt and nut	48.1 to 55.9	4.9 to 5.7	35.4 to 41.2
Rear support mounting screw (M12)	77.5 to 90.2	7.9 to 9.2	57.1 to 66.5
Hitch plate mounting bolt and nut (M14)	124 to 147	12.6 to 15.0	91 to 108
Fender bracket mounting bolt and nut (M14)	124 to 147	12.6 to 15.0	91 to 108
Fender center stay mounting screw (M14)	124 to 147	12.6 to 15.0	91 to 108
Control valve and PTO safety switch stay mounting screw	17.8 to 20.6	1.8 to 2.1	13.0 to 15.2
Delivery pipe	28.4 to 30.0	2.9 to 3.1	20.9 to 22.1
Power steering delivery hose	28.4 to 30.0	2.9 to 3.1	20.9 to 22.1
Mower lift arm mounting screw	77.5 to 90.2	7.9 to 9.2	57.1 to 66.5
Hydraulic cylinder mounting screw	39.2 to 44.1	4.0 to 4.5	28.9 to 32.5
Relief valve plug	39.2 to 58.8	4.0 to 6.0	28.9 to 43.4
Flow priority valve	39.2 to 58.8	4.0 to 6.0	28.9 to 43.4
Control valve plug	39.2 to 58.8	4.0 to 6.0	28.9 to 43.4
Pump cover mounting screw	34.3 to 39.2	3.5 to 4.0	25.3 to 28.9
Mower rear link mounting bolt and nut	124 to 147	12.6 to 15.0	91 to 108

W1012736

4. CHECKING, DISASSEMBLING AND SERVICING

[1] HYDRAULIC CONTROL VALVE, PUMP AND CYLINDER

(1) Checking and Adjusting

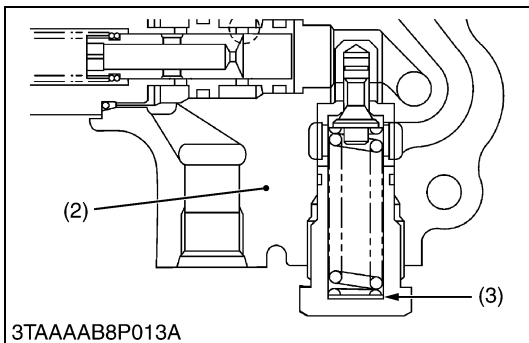
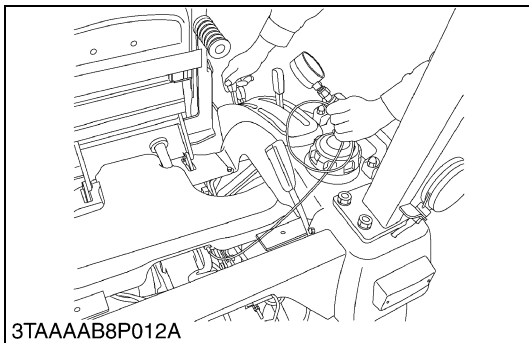
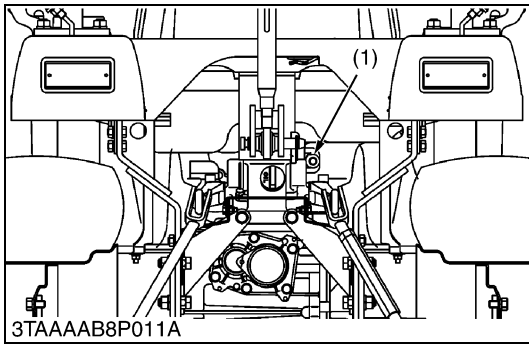

Relief Valve Setting Pressure

1. Remove the plug (1) (G1/4) from rear of hydraulic cylinder body.
2. Install the adaptor, cable and pressure gauge.
3. Lengthen the feedback rod for relief valve activation.
4. Start the engine and set at maximum speed.
5. Move the control lever all way up to operate the relief valve and read the gauge.
6. If the pressure is not within the factory specifications, adjust with the adjusting shims (3).
7. After checking, reset the feedback rod correctly.
(See page 5-S5.)

Relief valve setting pressure	Factory spec.	12.3 to 12.7 MPa 125 to 130 kgf/cm ² 1778 to 1849 psi

Condition

- Engine speed : Maximum
- Oil temperature : 45 to 55 °C
113 to 131 °F

(Reference)

- Thickness of shims (3) :
0.1 mm (0.0039 in.), 0.2 mm (0.0079 in.), 0.4 mm (0.0157 in.)
- 0.27 MPa (2.74 kgf/cm², 39.0 psi) pressure is increased whenever the thickness of adjusting shim is increased by 0.1 mm (0.0039 in.).

- (1) Plug (3) Shim
(2) Control Valve Assembly

W1011231

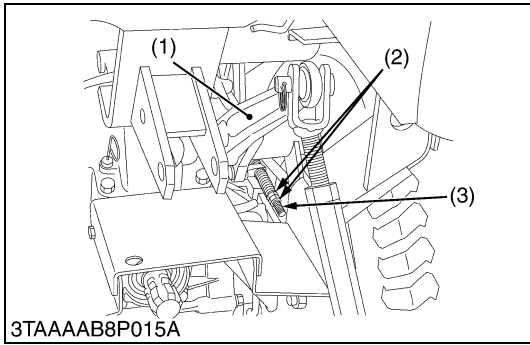
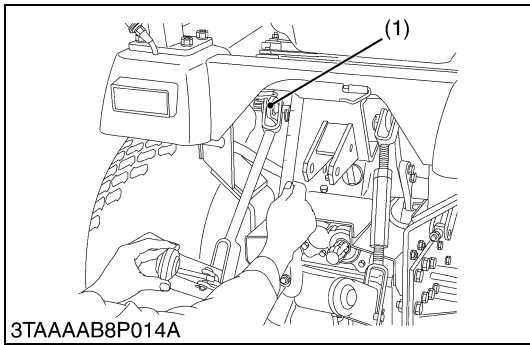

Lift Arm Free Play

1. Set the hydraulic control lever to the lowest position.
2. Start the engine, and set at the idling speed.
3. Move the hydraulic control lever to **Lift** position until the lift arm (1) moves to the uppermost position.
4. Move the lift arm (1) to the upper end by hand and measure the free play.
5. If the measurement is not within the factory specifications, adjust the free play by changing the set position of feedback rod rock nuts (2).

Lift arm free play	Factory spec.	5 to 10 mm 0.20 to 0.40 in.
--------------------	---------------	--------------------------------

- (1) Lift Arm (2) Rock Nut (3) Feedback Rod

W1011520

(2) Disassembling and Assembling

(A) Separating Hydraulic Control Valve, Pump and Cylinder

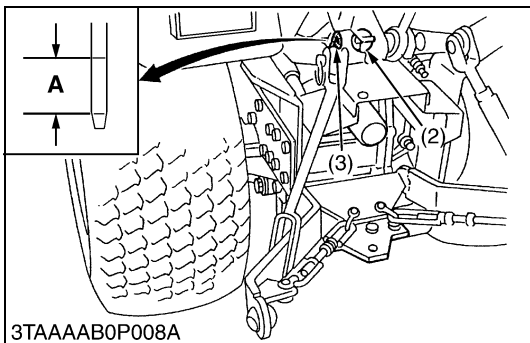
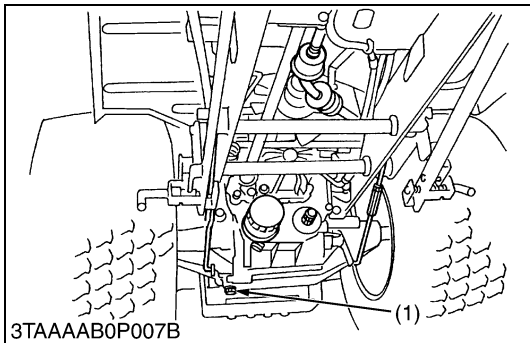

Draining Transmission Fluid

CAUTION

- **Be sure to stop the engine before checking and changing the transmission fluid.**
1. Place oil pan under the tractor.
 2. Remove the drain plugs (1) at the bottom of the transmission case.
 3. Drain the transmission fluid and reinstall the drain plug.

(When refilling)

- Fill new oil from filling port after removing the filling plug (2) up to the upper notch on the dipstick (3).
- After running the engine for few minutes, stop it and check the oil level again, if low, add oil to prescribed level.

IMPORTANT

- **Use only multi-grade transmission oil. Use of other oils may damage the transmission or hydraulic system. Refer to "LUBRICANTS, FUEL AND COOLANT". (See page G-7.)**
- **Never work the tractor immediately after changing the transmission oil. Keeping the engine at medium speed for a few minutes to prevents damage to the transmission.**
- **Do not mix different brands oil together.**

Transmission fluid capacity	10.1 L 2.7 U.S.gals. 2.2 Imp.gals.
-----------------------------	--

- (1) Drain Plug (2) Filling Plug (3) Dipstick
- A : Oil level is acceptable within this range**

W1030763

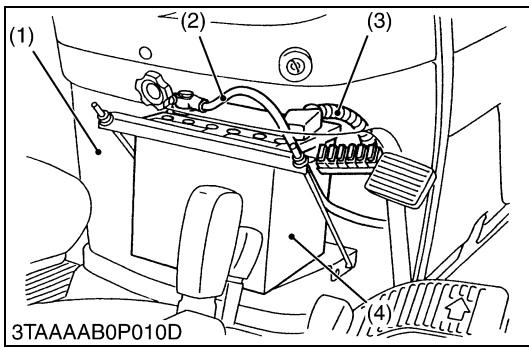

Battery

⚠ CAUTION

- When disconnecting the battery cables, disconnect the negative cable from the battery first. When connecting, connect the positive cable to the battery first.

1. Remove the under panel (1).
2. Disconnect the negative cable (2) from the battery.
3. Disconnect the positive cable (3) from the battery and remove the battery (4).

- (1) Under Panel
- (2) Negative Cable
- (3) Positive Cable
- (4) Battery

W1011994

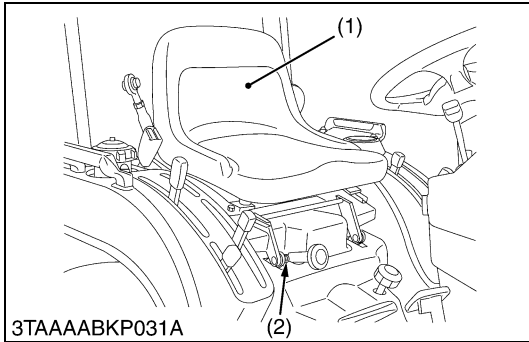

Seat

1. Remove the snap pin (2) to remove the seat (1).

- (1) Seat
- (2) Snap Pin

W1031755

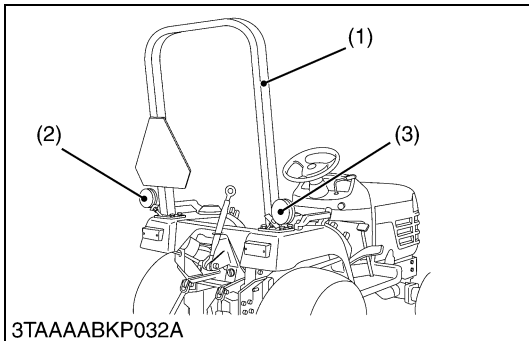

Roll-Over Protective Structures (ROPS)

1. Disconnect the lead wires from the hazard lights (2), (3).
2. Remove the ROPS mounting nuts and remove the ROPS (1).

(When reassembling)

Tightening torque	ROPS mounting nut	124 to 147 N·m 12.6 to 15.0 kgf·m 91 to 108 ft-lbs
-------------------	-------------------	--

- (1) ROPS
- (2) Hazard Light LH
- (3) Hazard Light RH

W1031820

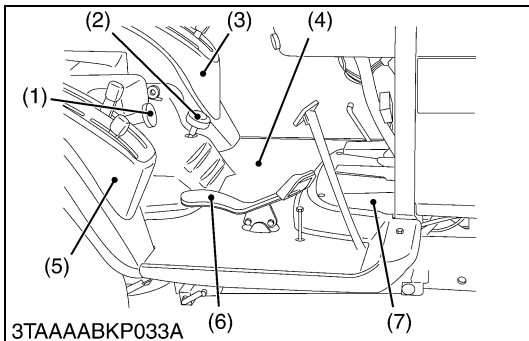

Speed Control Pedal, Lever Guides and Step

1. Remove the lowering speed adjusting knob (1) and cutting height adjusting dial knob (2).
2. Remove the step plate (7), speed control pedal (6) and lever guides (3), (5).
3. Remove the step (4).

- (1) Lowering Speed Adjusting Knob
- (2) Cutting Height Adjusting Dial Knob
- (3) Lever Guide LH
- (4) Step
- (5) Lever Guide RH
- (6) Speed Control Pedal
- (7) Step Plate

W1014726

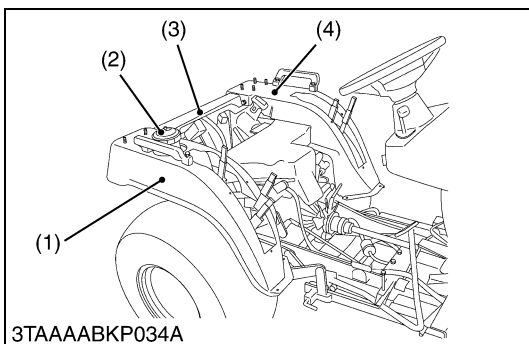

Fenders

1. Disconnect the lead wires from the tail lights.
2. Remove the fuel cap (2), then remove the fenders (1), (3) and (4) as a unit.
3. Replace the fuel cap (2).

- (1) Fender RH
- (2) Fuel Cap
- (3) Rear Fender
- (4) Fender LH

W1031415

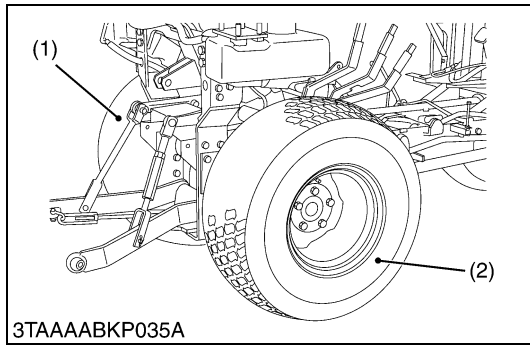

Rear Wheel

1. Remove the rear wheels (1) and (2).

(When reassembling)

Tightening torque	Rear wheel mounting screw	108.5 to 130.2 N·m 11.1 to 13.2 kgf·m 80 to 96 ft-lbs
-------------------	---------------------------	---

(1) Rear Wheel LH

(2) Rear Wheel RH

W1033482

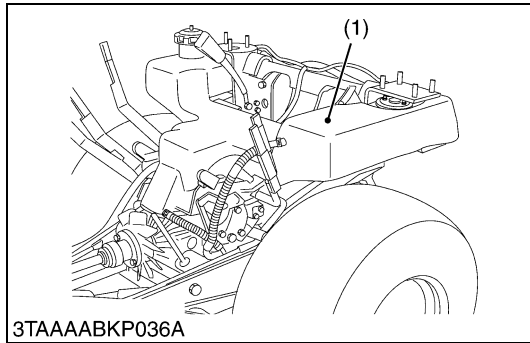

Fuel Tank

1. Drain the fuel.
2. Disconnect the lead wire from fuel level sensor and fuel hoses from the fuel tank (1).
3. Remove the fuel tank stays (2), (3) and cushions, then remove the fuel tank (1).

(When reassembling)

Tightening torque	Fuel tank stay mounting bolt and nut	48.1 to 55.9 N·m 4.9 to 5.7 kgf·m 35.4 to 41.2 ft-lbs
-------------------	--------------------------------------	---

(1) Fuel Tank

(3) Fuel Tank Stay RH

(2) Fuel Tank Stay LH

W1033616

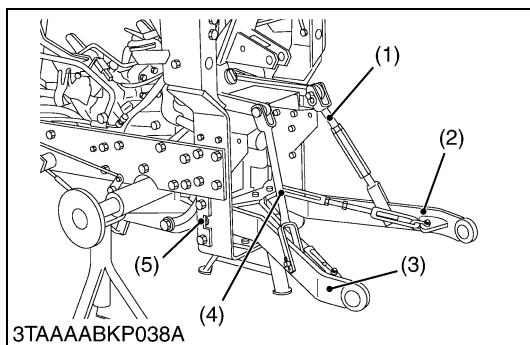
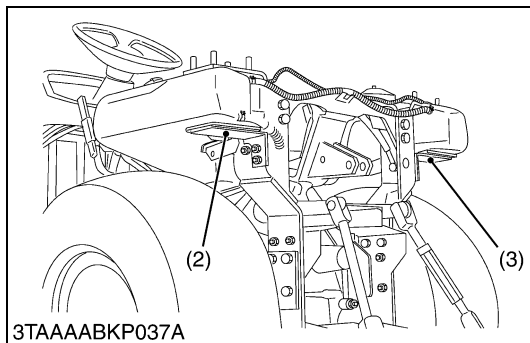

Lift Rod and Lower Link

1. Remove the lift rods (1) and (4).
2. Remove the stopper plate LH (5), then tap out the lower link pin to remove the lower links (2), (3) with check chains as a unit.

(When reassembling)

Tightening torque	Stopper plate mounting bolt and nut	77.5 to 90.2 N·m 7.9 to 9.2 kgf·m 57.1 to 66.5 ft-lbs
-------------------	-------------------------------------	---

(1) Lift Rod RH

(4) Lift Rod LH

(2) Lower Link RH

(5) Stopper Plate

(3) Lower Link LH

W1026695

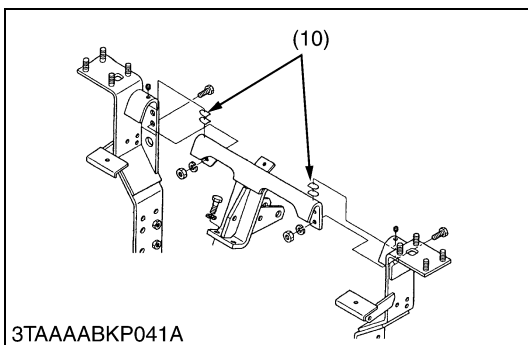
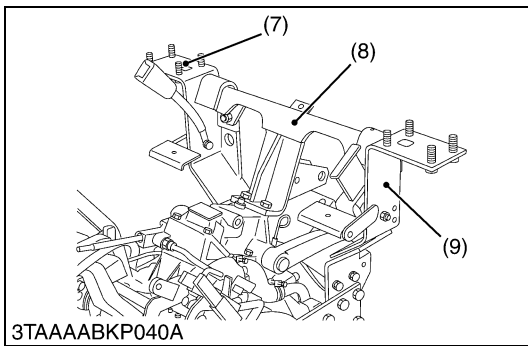
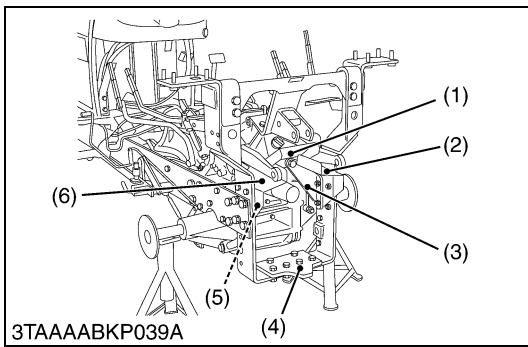

PTO Cover, Fender Bracket, Hitch Plate and Others

1. Remove the PTO covers (1), (2) and (6).
2. Remove the hitch plate (4) and rear supports (3), (5).
3. Remove the fender brackets (7), (9), shim (10) and fender center stay (8).

(When reassembling)

- Do not firmly tighten all screws, bolts and nuts until most components are attached.
- After the all screws, bolts and nuts are tighten to the specified torque, install and secure the shim (10) with hexagonal socket head screw between fender brackets (7), (9) and fender center stay (8).
- When tightening the upper PTO cover (1) mounting bolts and nuts, adjust the operating force to 29.4 to 49.0 N (3.0 to 5.0 kgf, 6.6 to 11.0 lbs).

Tightening torque	PTO cover RH and LH mounting bolt and nut	48.1 to 55.9 N·m 4.9 to 5.7 kgf·m 35.4 to 41.2 ft-lbs
	Rear support mounting screw (M12)	77.5 to 90.2 N·m 7.9 to 9.2 kgf·m 57.1 to 66.5 ft-lbs
	Hitch plate mounting bolt and nut (M14)	124 to 147 N·m 12.6 to 15.0 kgf·m 91 to 108 ft-lbs
	Fender bracket mounting bolt and nut (M14)	124 to 147 N·m 12.6 to 15.0 kgf·m 91 to 108 ft-lbs
	Fender center stay mounting screw (M14)	124 to 147 N·m 12.6 to 15.0 kgf·m 91 to 108 ft-lbs

(Reference)

- Thickness of shim (10) : 1.2 mm (0.047 in.)
1.5 mm (0.059 in.)
1.9 mm (0.075 in.)

- | | |
|---------------------|------------------------|
| (1) Upper PTO Cover | (6) PTO Cover LH |
| (2) PTO Cover RH | (7) Fender Bracket RH |
| (3) Rear Support RH | (8) Fender Center Stay |
| (4) Hitch Plate | (9) Fender Bracket LH |
| (5) Rear Support LH | (10) Shim |

W1026852

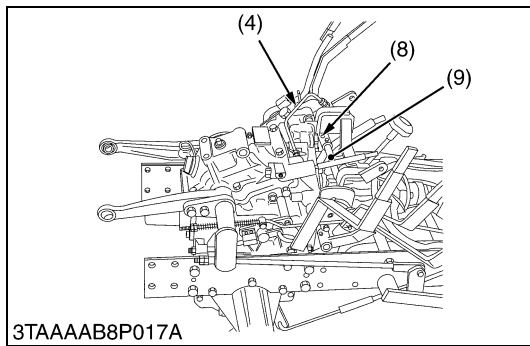
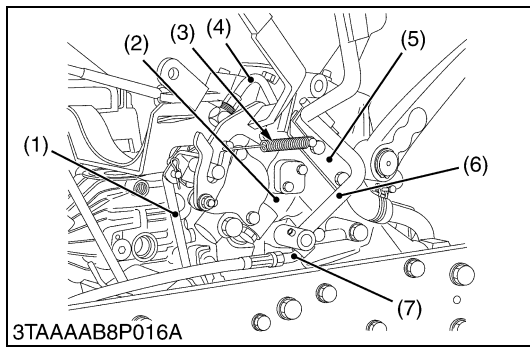

Hydraulic Control Valve

1. Tap out the spring pin and remove the PTO select lever (6).
2. Disconnect the PTO clutch lever rod (1).
3. Remove the delivery pipe (4).
4. Disconnect the power steering delivery hose (7).
5. Remove the rue ring cotter and remove the clevis pin (8) for hydraulic control lever shaft (9).
6. Remove the spring (3) and separate the hydraulic control valve assembly (2) and PTO safety switch stay (5).

(When reassembling)

- Be sure to install the O-ring and take care not to damage the O-ring.

Tightening torque	Control valve and PTO safety switch stay mounting screw	17.8 to 20.6 N-m 1.8 to 2.1 kgf-m 13.0 to 15.2 ft-lbs
	Delivery pipe	28.4 to 30.0 N-m 2.9 to 3.1 kgf-m 20.9 to 22.1 ft-lbs
	Power steering delivery hose	28.4 to 30.0 N-m 2.9 to 3.1 kgf-m 20.9 to 22.1 ft-lbs

- | | |
|----------------------------|-----------------------------------|
| (1) PTO Clutch Lever Rod | (6) PTO Select Lever |
| (2) Control Valve Assembly | (7) Power Steering Delivery Hose |
| (3) Spring | (8) Clevis Pin |
| (4) Delivery Pipe | (9) Hydraulic Control Lever Shaft |
| (5) PTO Safety Switch Stay | |

W1013072

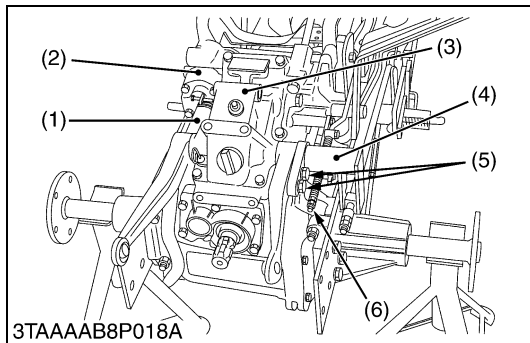

Hydraulic Pump and Hydraulic Cylinder

1. Loosen the hose clamp and disconnect the suction hose (1).
2. Remove the hydraulic pump (2).
3. Disconnect the feedback rod (6) at the lift arm.
4. Remove the mower lift arm mounting screws (5).
5. Remove the hydraulic cylinder mounting screws and dismount the hydraulic cylinder (3).

(When reassembling)

- Take care not to damage the O-ring for hydraulic pump.
- Apply liquid gasket (Three Bond 1208D or equivalent) to the joint face of transmission case to hydraulic cylinder.

Tightening torque	Mower lift arm mounting screw	77.5 to 90.2 N-m 7.9 to 9.2 kgf-m 57.1 to 66.5 ft-lbs
	Hydraulic cylinder mounting screw	39.2 to 44.1 N-m 4.0 to 4.5 kgf-m 28.9 to 32.5 ft-lbs

- | | |
|------------------------|--------------------|
| (1) Suction Hose | (4) Mower Lift Arm |
| (2) Hydraulic Pump | (5) Screw |
| (3) Hydraulic Cylinder | (6) Feedback Rod |

W1013457

(B) Disassembling Control Valve Assembly

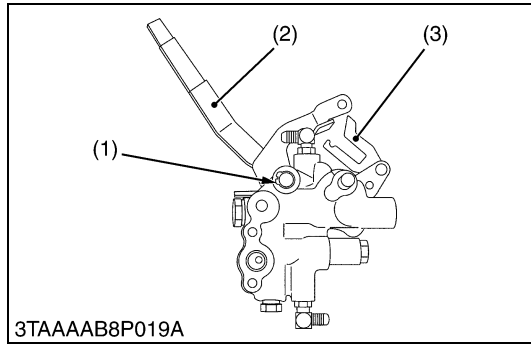

PTO Clutch Lever and PTO Clutch Cam

1. Remove the external snap ring (1) and remove the PTO clutch lever (2).
2. Remove the PTO clutch cam (3).

(When reassembling)

- Apply grease to the PTO clutch cam.

- | | |
|------------------------|--------------------|
| (1) External Snap Ring | (3) PTO Clutch Cam |
| (2) PTO Clutch Lever | |

W1013717

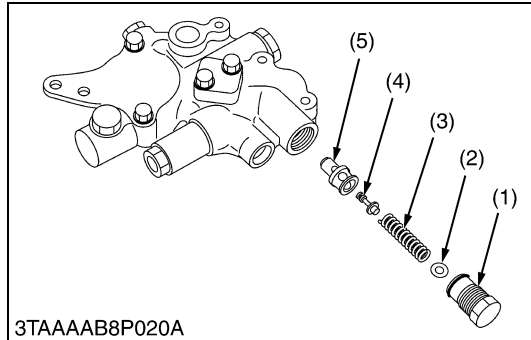

Relief Valve

1. Remove the plug (1), and draw out the shim (2), spring (3), poppet (4) and the valve seat (5).

(When reassembling)

- Take care not to damage the O-ring.

Tightening torque	Relief valve plug	39.2 to 58.8 N·m 4.0 to 6.0 kgf·m 28.9 to 43.4 ft·lbs
-------------------	-------------------	---

■ IMPORTANT

- After disassembling and assembling the relief valve, be sure to adjust the relief valve setting pressure. (See page 5-S3.)

- | | |
|------------|----------------|
| (1) Plug | (4) Poppet |
| (2) Shim | (5) Valve Seat |
| (3) Spring | |

W1013981

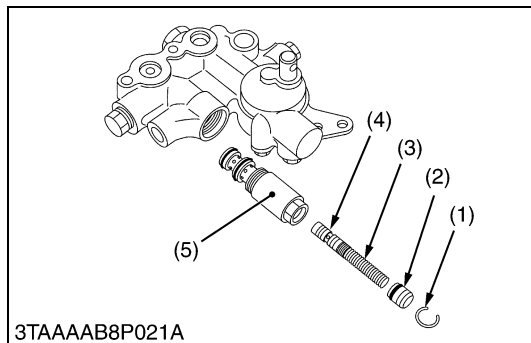

Flow Priority Valve

1. Remove the flow priority valve assembly.
2. Remove the stopper ring (1) while pressing the plug (2).
3. Remove the spool (4) with spring (3).

(When reassembling)

- Take care not to damage the O-rings.

Tightening torque	Flow priority valve	39.2 to 58.8 N·m 4.0 to 6.0 kgf·m 28.9 to 43.4 ft·lbs
-------------------	---------------------	---

- | | |
|------------------|-----------|
| (1) Stopper Ring | (4) Spool |
| (2) Plug | (5) Body |
| (3) Spring | |

W1014148

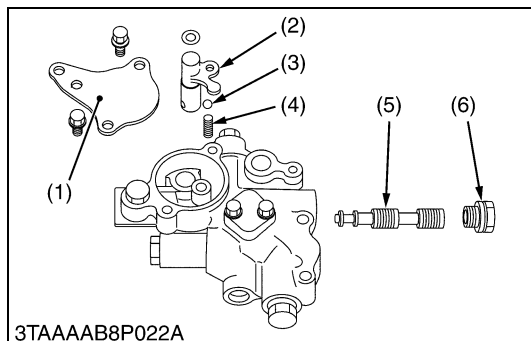

Control Valve Spool and Control Arm

1. Remove the valve cover (1).
2. Remove the control arm (2), ball (3) and spring (4).
3. Remove the control valve plug (6) and draw out the spool (5).

(When reassembling)

- Take care not to damage the O-rings.

Tightening torque	Control valve plug (6)	39.2 to 58.8 N·m 4.0 to 6.0 kgf·m 28.9 to 43.4 ft·lbs
-------------------	------------------------	---

- | | |
|-----------------|------------------------|
| (1) Valve Cover | (4) Spring |
| (2) Control Arm | (5) Spool |
| (3) Ball | (6) Control Valve Plug |

W1014310

(C) Disassembling Hydraulic Pump

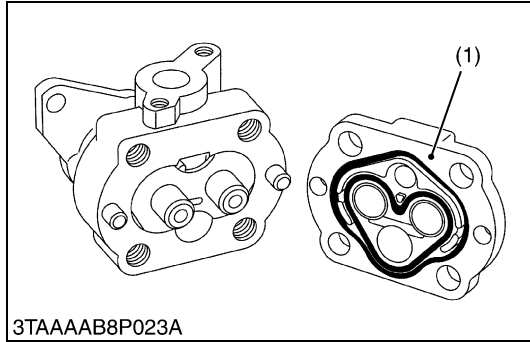

Pump Cover

1. Secure the hydraulic pump with a vise, and remove the pump cover (1).

(When reassembling)

- Take care not to damage the O-ring.
- Align the holes of the pump cover and casing.

Tightening torque	Pump cover mounting screw	34.3 to 39.2 N·m 3.5 to 4.0 kgf·m 25.3 to 28.9 ft-lbs
-------------------	---------------------------	---

(1) Pump Cover

W1014503

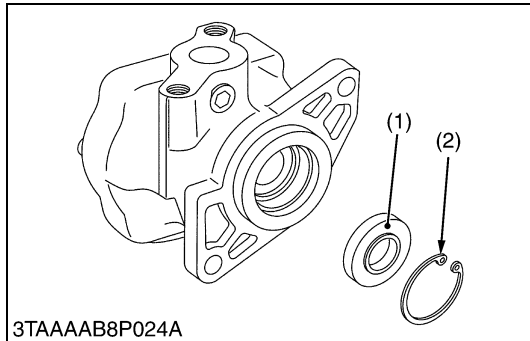

Oil Seal

1. Remove the internal snap ring (2), and remove the oil seal (1).

(When reassembling)

- If the oil seal is defective, worn or scratched, replace it.

(1) Oil Seal

(2) Internal Snap Ring

W1014788

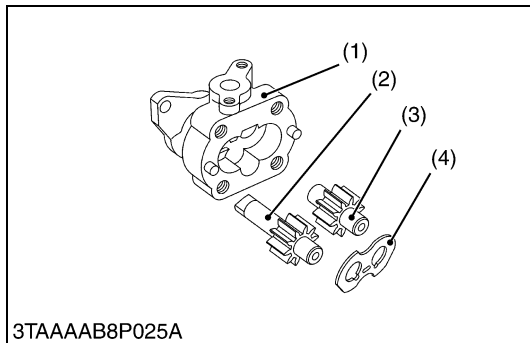

Side Plate and Gear

1. Remove the side plate (4).

2. Remove the drive gear (2) and driven gear (3) from the casing (1).

(When reassembling)

- Install the side plate, noting its location and direction.
- Install the gears, noting its direction.

(1) Casing

(3) Driven Gear

(2) Drive Gear

(4) Side Plate

W1014898

(D) Disassembling Hydraulic Cylinder

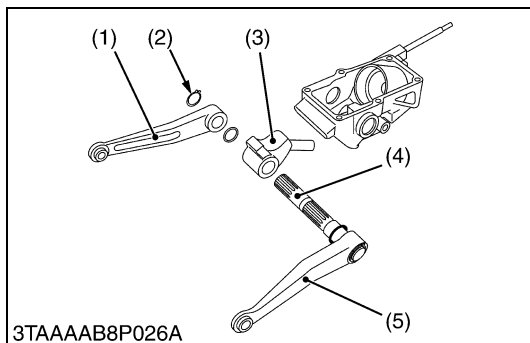

Lift Arm, Hydraulic Arm Shaft and Hydraulic Arm

1. Remove the external snap ring (2), and remove the lift arm RH (1).

2. Draw out the hydraulic arm shaft (4) and lift arm LH (5) as a unit.

(When reassembling)

- Align the alignment marks of the hydraulic arm (3) and hydraulic arm shaft (4).
- Align the alignment marks of the lift arm RH (1) and hydraulic arm shaft (4).
- Apply grease to the right and left bushings and O-rings.
- Take care not to damage the O-ring.

(1) Lift Arm RH

(4) Hydraulic Arm Shaft

(2) External Snap Ring

(5) Lift Arm LH

(3) Hydraulic Arm

W1015040

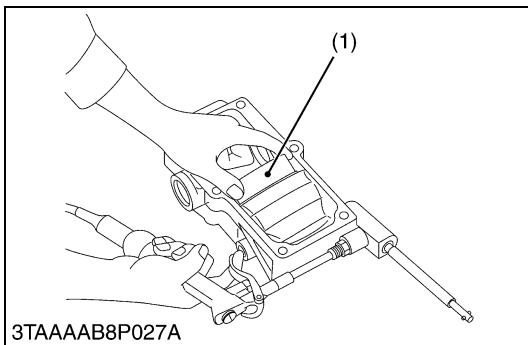

Hydraulic Piston

1. Inject the compressed air into the hydraulic cylinder, and take out the hydraulic piston (1).

(When reassembling)

- Take care not to damage the O-ring (3) and backup ring (2).
- Apply transmission fluid to the O-ring.
- Replace the O-ring if it is defective, worn or scratched, which may cause oil leakage.

- (1) Hydraulic Piston (3) O-ring
 (2) Backup Ring

W1015387

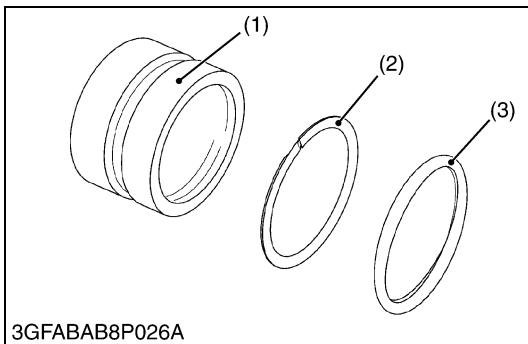

Lowering Speed Adjusting Valve

1. Remove the internal snap ring (4) and the remove the lowering speed adjusting shaft (5).
2. Remove the ball (2) and spring (1).

(When reassembling)

- Take care not to damage the O-rings.

- (1) Spring (4) Internal Snap Ring
 (2) Ball (5) Lowering Speed Adjusting Shaft
 (3) Stopper

W1015612

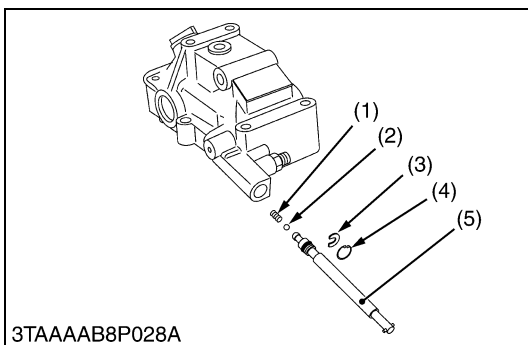

(3) Servicing

(A) Hydraulic Pump

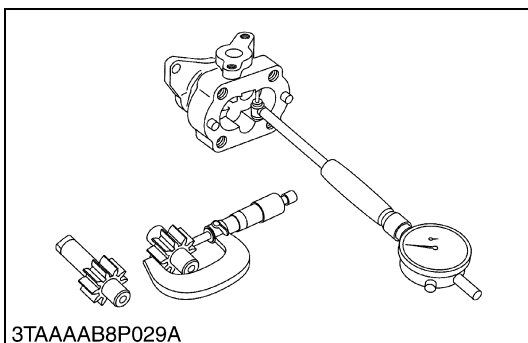

Clearance between Tip of Gear Tooth and Casing

1. Measure the gear O.D. with an outside micrometer.
2. Measure the casing I.D. with a cylinder gauge.
3. If the clearance exceeds the allowable limit, replace the assembly.

Clearance between tip of gear tooth and casing	Allowable limit	0.15 mm 0.0059 in.
--	-----------------	-----------------------

W1015764

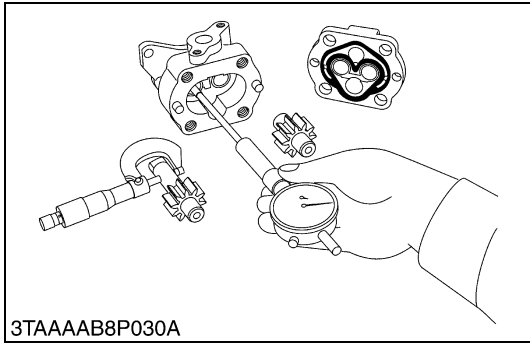

Clearance between Bushing and Shaft

1. Measure the gear shaft O.D. with an outside micrometer.
2. Measure the bushing I.D. with a cylinder gauge.
3. If the clearance exceeds the allowable limit, replace it.

Clearance between bushing and shaft	Factory spec.	0.020 to 0.091 mm 0.0008 to 0.0036 in.
	Allowable limit	0.12 mm 0.0047 in.

Shaft O.D.	Factory spec.	14.970 to 14.980 mm 0.5894 to 0.5898 in.
Bushing I.D.	Factory spec.	15.000 to 15.061 mm 0.5906 to 0.5930 in.

W1015972

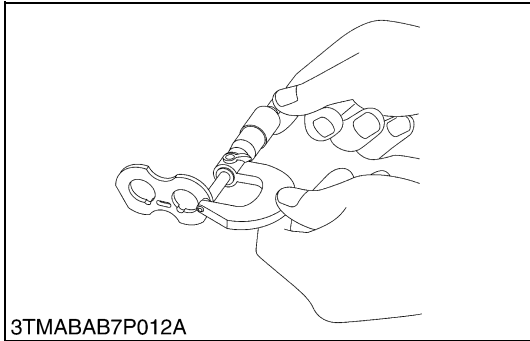

Side Plate Thickness

1. Measure the side plate thickness with an outside micrometer.
2. If the thickness is less than the allowable limit, replace it.

Side plate thickness	Factory spec.	2.48 to 2.50 mm 0.0976 to 0.0984 in.
	Allowable limit	2.40 mm 0.0945 in.

W1016194

(B) Hydraulic Cylinder

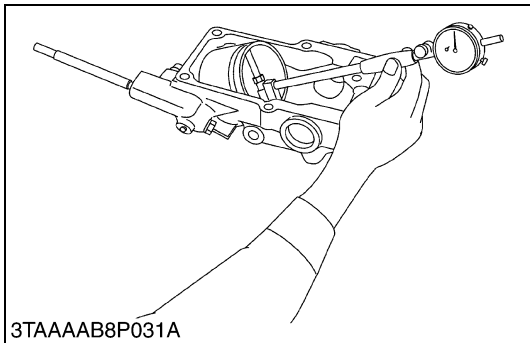

Hydraulic Cylinder Bore

1. Check the cylinder internal surface for scoring or damage.
2. Measure the cylinder I.D. with a cylinder gauge.
3. If the measurement exceeds the allowable limit, replace the hydraulic cylinder block.

Cylinder I.D.	Factory spec.	80.05 to 80.15 mm 3.1516 to 3.1555 in.
	Allowable limit	80.2 mm 3.1575 in.

W10171300

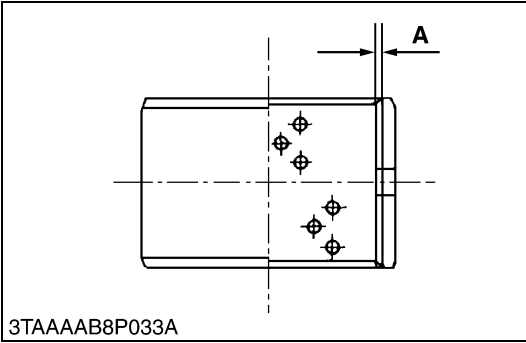
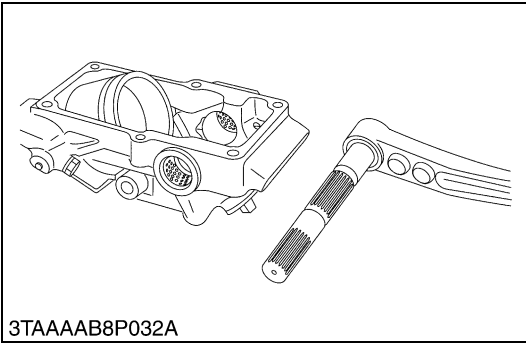

Hydraulic Arm Shaft Bushing

1. Visually inspect the DX bushings for signs of wear or damage. (The DX bushing tends to show concentrated wear.)
2. If the DX bushing is worn beyond the alloy thickness (**A**), replace it.

(Reference)

Hydraulic arm shaft bushing	Alloy thickness (A)	0.57 mm 0.0224 in.
-----------------------------	------------------------------	-----------------------

Hydraulic arm shaft	LH	O.D.	31.925 to 31.950 mm 1.2569 to 1.2579 in.
	RH	O.D.	29.925 to 29.950 mm 1.1781 to 1.1791 in.

W1016329

[2] MOWER LIFT LINKAGE

Disassembling Mower Linkage

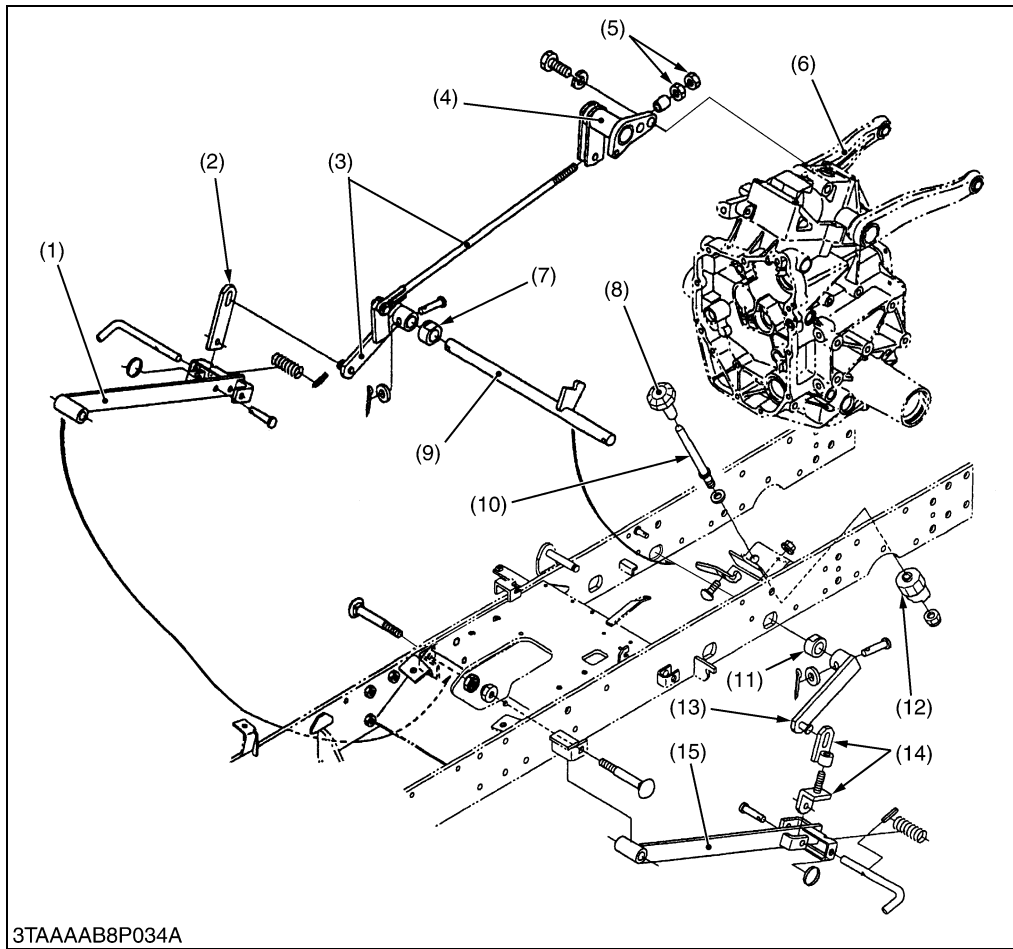

3TAAAAB8P034A

- (1) Mower Rear Link RH
- (2) Lift Link RH
- (3) Lift Link Rear RH
- (4) Mower Lift Arm
- (5) Link Adjusting Nut
- (6) Lift Arm RH
- (7) Bush
- (8) Cutting Height Adjusting Dial Knob
- (9) Rear Lift Link Shaft
- (10) Cutting Height Adjusting Rod
- (11) Bush
- (12) Adjusting Cam
- (13) Lift Link Rear LH
- (14) Lift Link LH
- (15) Mower Rear Link LH

W1016616

1. Remove the clevis pin and remove the mower rear link (1), (15) and lift link (2), (14).
2. Remove the clevis pin and remove the lift link rear LH (13).
3. Remove the clevis pin and mower lift arm mounting screws, and remove the lift link rear RH (3) with mower lift arm (4) as a unit.
4. Remove the both side of bushes (7), (11) and remove the rear lift link shaft (9).
5. Remove the cutting height adjusting dial knob (8).
6. Remove the nut and remove the adjusting cam (12) and cutting height adjusting rod (10).

(When reassembling)

Tightening torque	Mower lift arm mounting screw	77.4 to 90.2 N·m 7.9 to 9.2 kgf·m 57.1 to 66.5 ft·lbs
	Mower rear link mounting bolt and nut	124 to 147 N·m 12.6 to 15.0 kgf·m 91 to 108 ft·lbs

W1016794

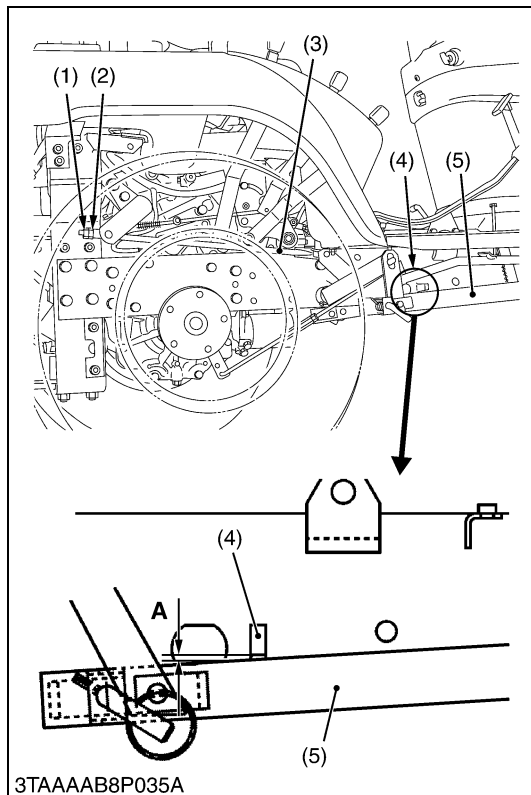

3TAAAAB8P035A

Adjusting Mower Lift Linkage

After reassembling, be sure to adjust the mower lift linkages as follows.

1. Adjust the lift arm free play. (See page 5-S5.)
2. Loosen the adjusting nut (1), (2) and start the engine.
3. Move the hydraulic control lever to **Lift** position until the relief valve operating (**Uppermost** position).
4. Tighten the adjusting nut (2) until the clearance between stopper (4) and mower rear link RH (5) gets 0 to 1.0 mm (0 to 0.04 in.).
5. Secure the lock nut (1).

- (1) Lock Nut
- (2) Adjusting Nut
- (3) Adjusting Rod (Lift Link Rear RH)
- (4) Stopper
- (5) Mower Rear Link RH

A : Clearance between stopper and mower rear link LH

W1016972

6 ELECTRICAL SYSTEM

MECHANISM

CONTENTS

1. WIRING DIAGRAM	6-M1
2. STARTING SYSTEM	6-M4
[1] STARTER	6-M5
[2] GLOW PLUG	6-M6
[3] SAFETY SWITCH	6-M6
[4] FUEL PUMP	6-M7
[5] ENGINE STOP SOLENOID	6-M7
3. CHARGING SYSTEM	6-M8
[1] AC DYNAMO	6-M9
[2] REGULATOR	6-M9
4. LIGHTING SYSTEM	6-M10
[1] HEAD LIGHT	6-M11
[2] TURN SIGNAL LIGHT	6-M11
[3] HAZARD LIGHT	6-M12
[4] EASY CHECKER	6-M12
5. GAUGES	6-M13
[1] FUEL QUANTITY	6-M13
[2] COOLANT TEMPERATURE	6-M14

1. WIRING DIAGRAM

Color of Wiring

W White	WR White / Red	BW Black / White
R Red	WY White / Yellow	BR Black / Red
L Blue	RB Red / Black	GW Green / White
P Pink	RW Red / White	YR Yellow / Red
B Black	RG Red / Green	YL Yellow / Blue
Br Brown	RY Red / Yellow	LW Blue / White
Sb Sky Blue		

W1019456

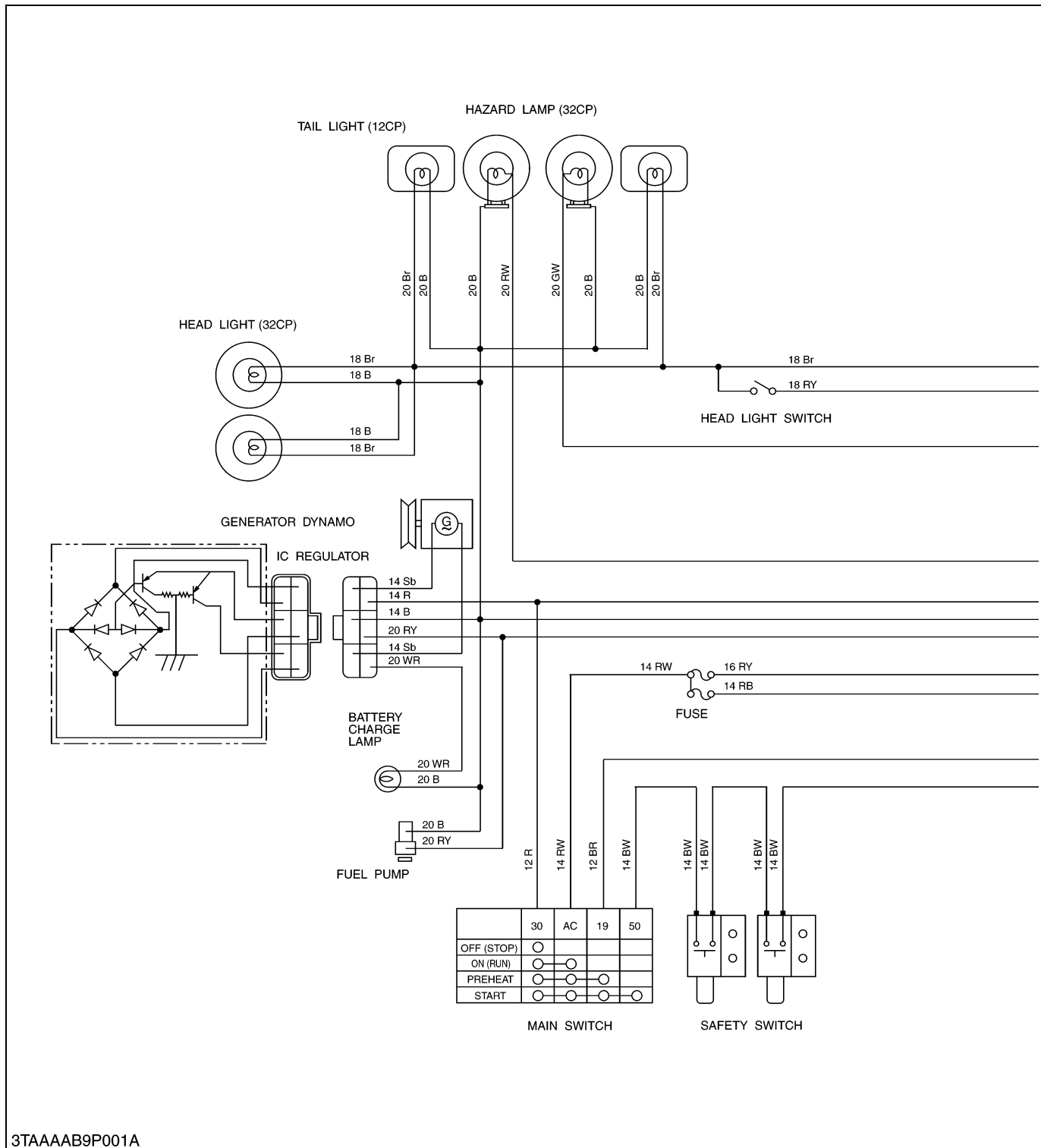

3TAAAB9P001A

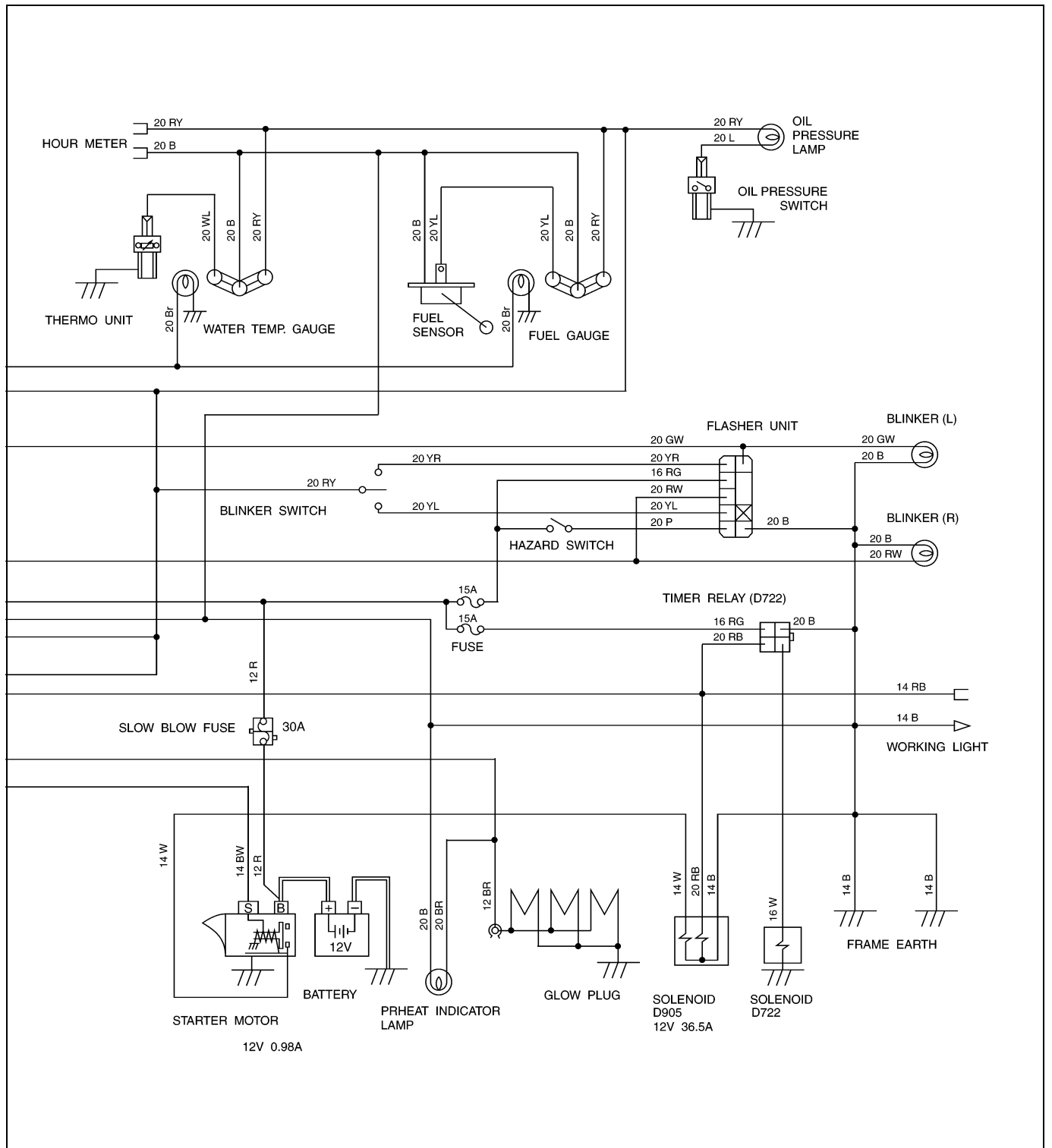

2. STARTING SYSTEM

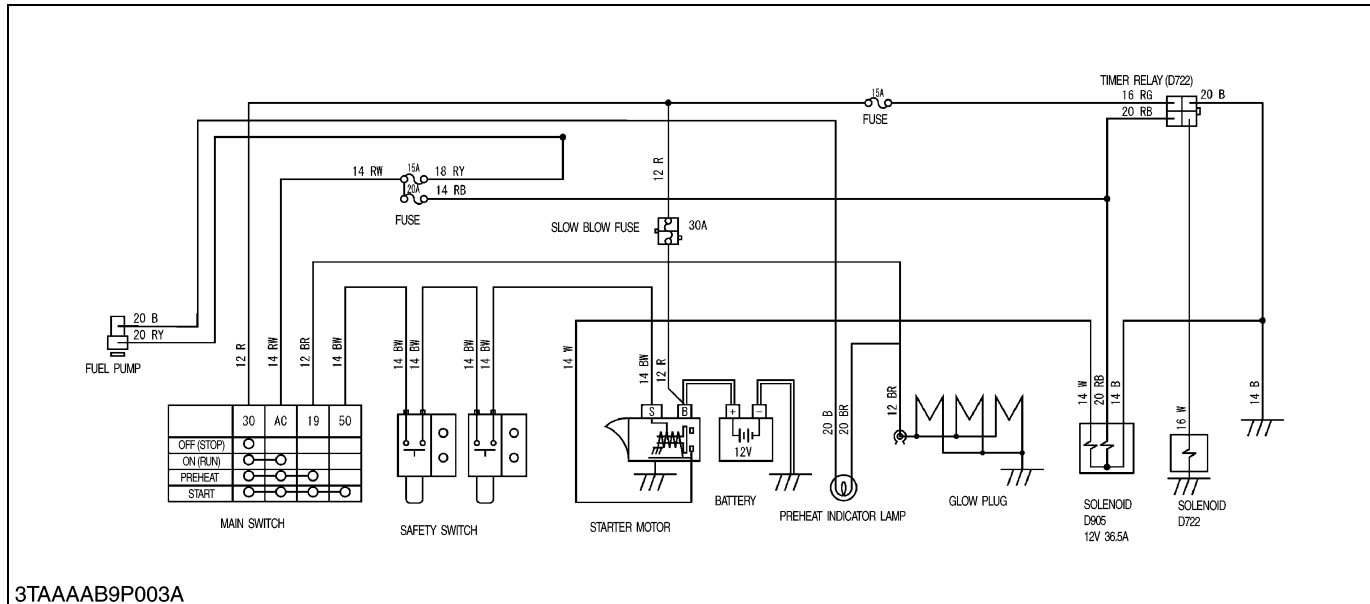

When the main switch is turned to the **PREHEAT** position, the terminal **30** is connected to the terminals **19** and **AC**. The glow plugs become red-hot, and the preheat indicator lamp also lights on while preheating.

When the main switch is then turned to the **START** position with the safety switches on, the terminal **30** is connected to the terminals **50** and **AC**. Consequently, battery current flows to the starter motor and start the engine.

The main switch automatically returns to the **ON** position, the terminal **30** is connected only to the terminal **AC**, thereby causing the starting circuit to be opened, stopping the starter motor.

When the main switch turned from the **ON** position to the **OFF** position, the fuel cut-off solenoid moves the fuel injection pump control rack to the “**No Fuel Injection**” position and stop the engine.

[1] STARTER

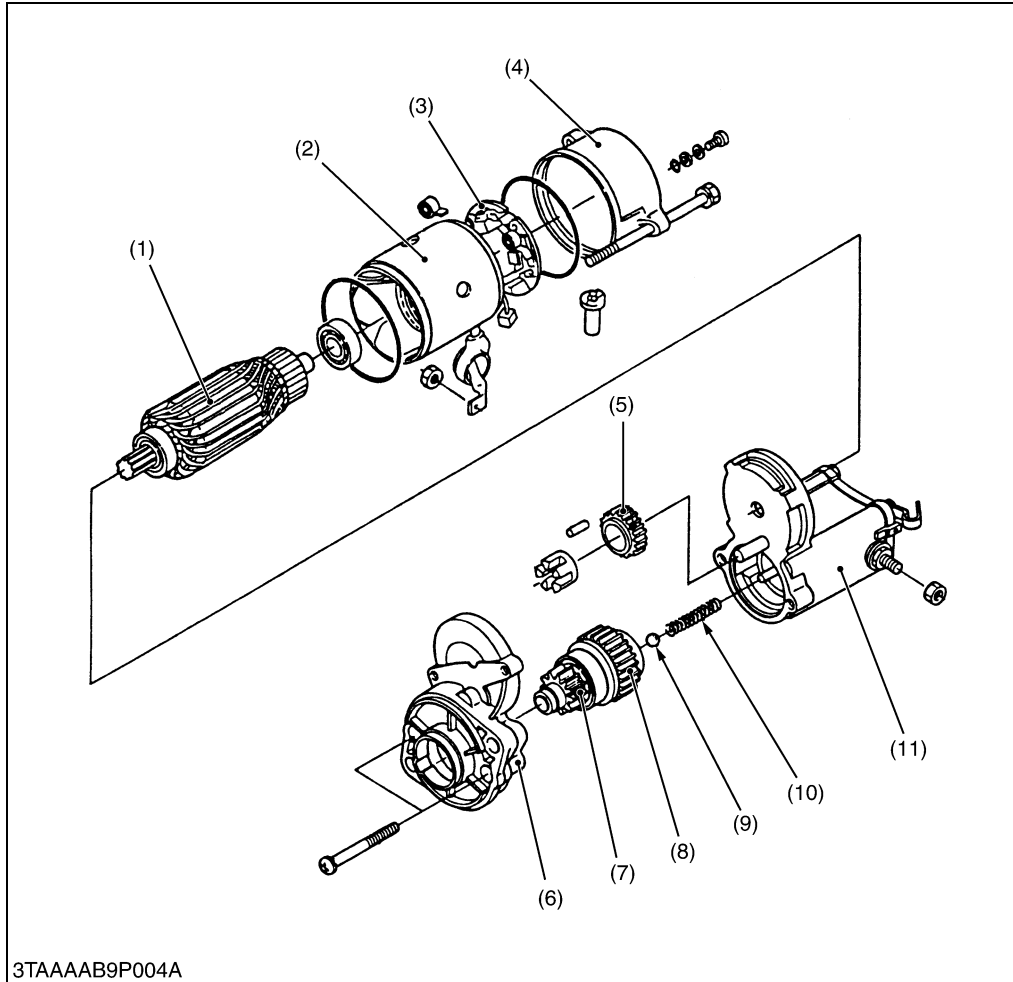

- (1) Armature
- (2) Yoke
- (3) Brush Holder
- (4) End Frame
- (5) Gear
- (6) Drive End Frame
- (7) Pinion
- (8) Roller Clutch
- (9) Ball
- (10) Spring
- (11) Magnet Switch

W1013045

3TAAAB9P004A

The starter motor is a reduction type. The speed of the pinion gear is reduced to approximately one third of motor one.

[2] GLOW PLUG

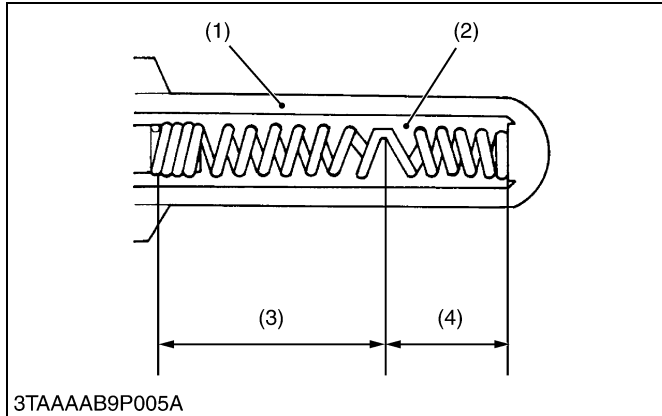

3TAAAAB9P005A

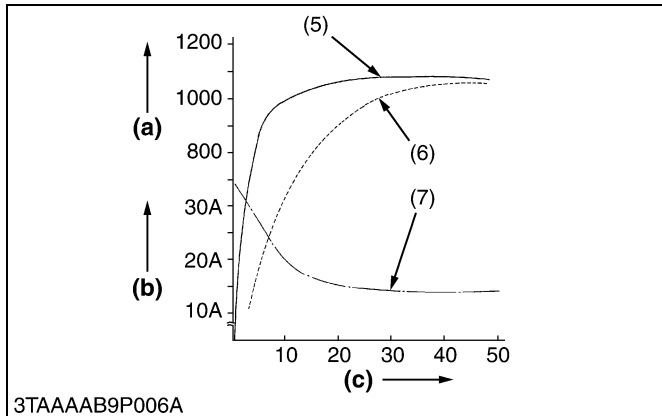

3TAAAAB9P006A

This plug is a two-material type QGS (Quick Glow System) for quick temperature rise, and has self-controlling function as well as excellent durability.

The heater (4) connected in series to the heater (3), which also functions as the resistor, is incorporated in the sheath tube (1) of the super glow plug.

The resistance of this heater (3) cum resistor is small when the temperature is low, while the resistance becomes large when the temperature rises.

Therefore, because sufficient current is flown to the heater (4) during the initial period of energization, the temperature rises quickly and the resistance grows with the rise in the temperature of the resistor, the flowing current is reduced to prevent the heater (4) from being heated.

The ignition point is in the area of 2 to 3 mm (0.079 to 0.118 in.) from the tip of the plug in order to reduce its projection into the combustion chamber.

- (1) Sheath Tube
 - (2) Insulation Powder
 - (3) Heater also functioning as a Resistor
 - (4) Heater
 - (5) Super Glow Plug
 - (6) Conventional Quick-heating type Glow Plug
 - (7) Glow Plug Current
- (a) Glow Plug Temperature (°C)
 - (b) Current (A)
 - (c) Time (Sec.)

W1013322

[3] SAFETY SWITCH

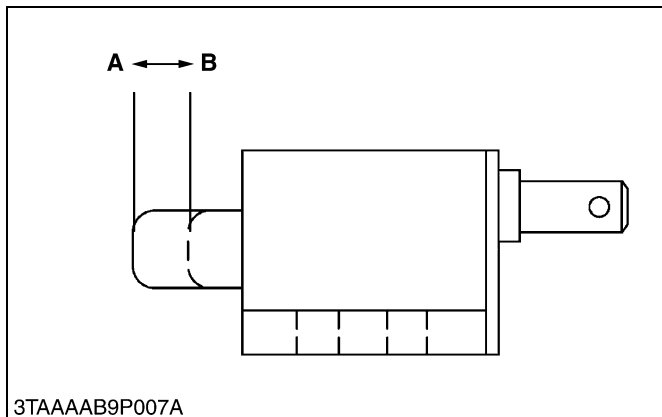

3TAAAAB9P007A

The safety switch prevents current from flowing to the starter when the safety switches are not depressed. This is to ensure safe starting.

The safety switches are located three (clutch pedal, PTO gear shift lever and range gear shift lever) different position.

- A : OFF
- B : ON

W1013107

[4] FUEL PUMP

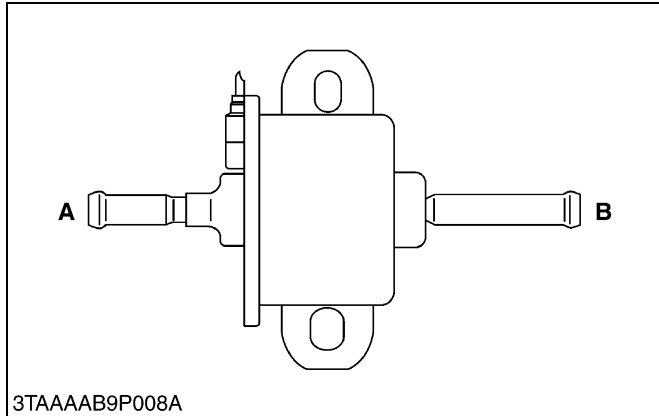

3TAAAAB9P008A

An electro magnetic fuel pump uses a transistor that causes the pump to start pumping fuel when the main switch is turned to the “ON” position.

Therefore, fuel is supplied to the fuel injection pump regardless of engine speed. This pump is driven by the battery. It can therefore be operated even with the engine being stopped.

A: Inlet

B: Outlet

W1013592

[5] ENGINE STOP SOLENOID

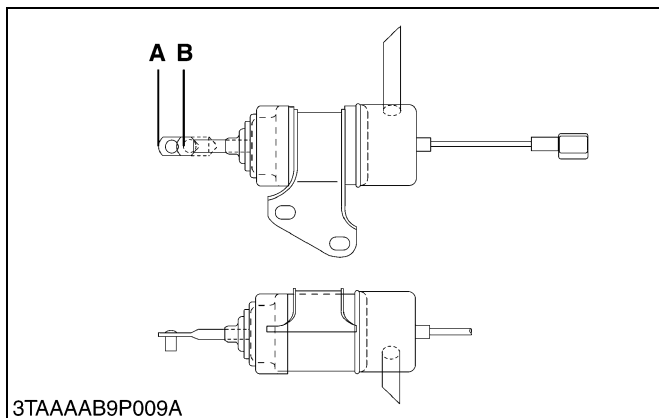

3TAAAAB9P009A

■ D722-E-BX

The timer relay is provided to actuate the engine stop solenoid approx. 10 seconds to stop after the main switch is turned from ON position to OFF position.

Flowing of the battery current into the coil while the timer relay contact point is closed attracts the plunger to actuate the stop lever of the injection pump. When the battery current stops, the plunger is returned to the original position by the spring.

A: ON

B: OFF

W1013394

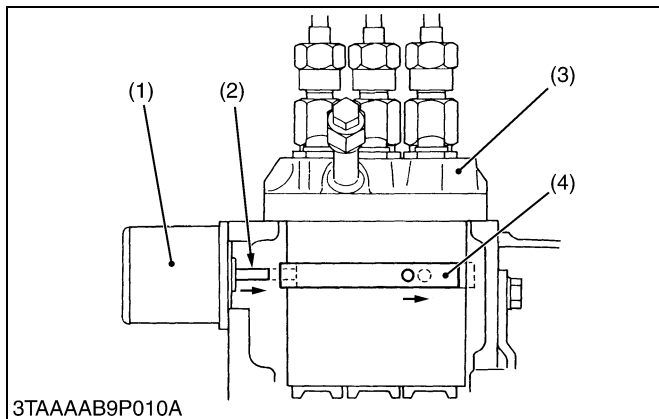

3TAAAAB9P010A

■ D905-E-BX

Flowing of the battery current into the engine stop solenoid, the plunger (2) move to right side so that the movement of control rack (4) becomes free. When the battery current stops, the plunger (2) is returned to the original position by the spring to keep the control rack (4) in “No fuel injection” position.

- (1) Engine Stop Solenoid
- (2) Plunger

- (3) Injection Pump
- (4) Control Rack

W1013496

3. CHARGING SYSTEM

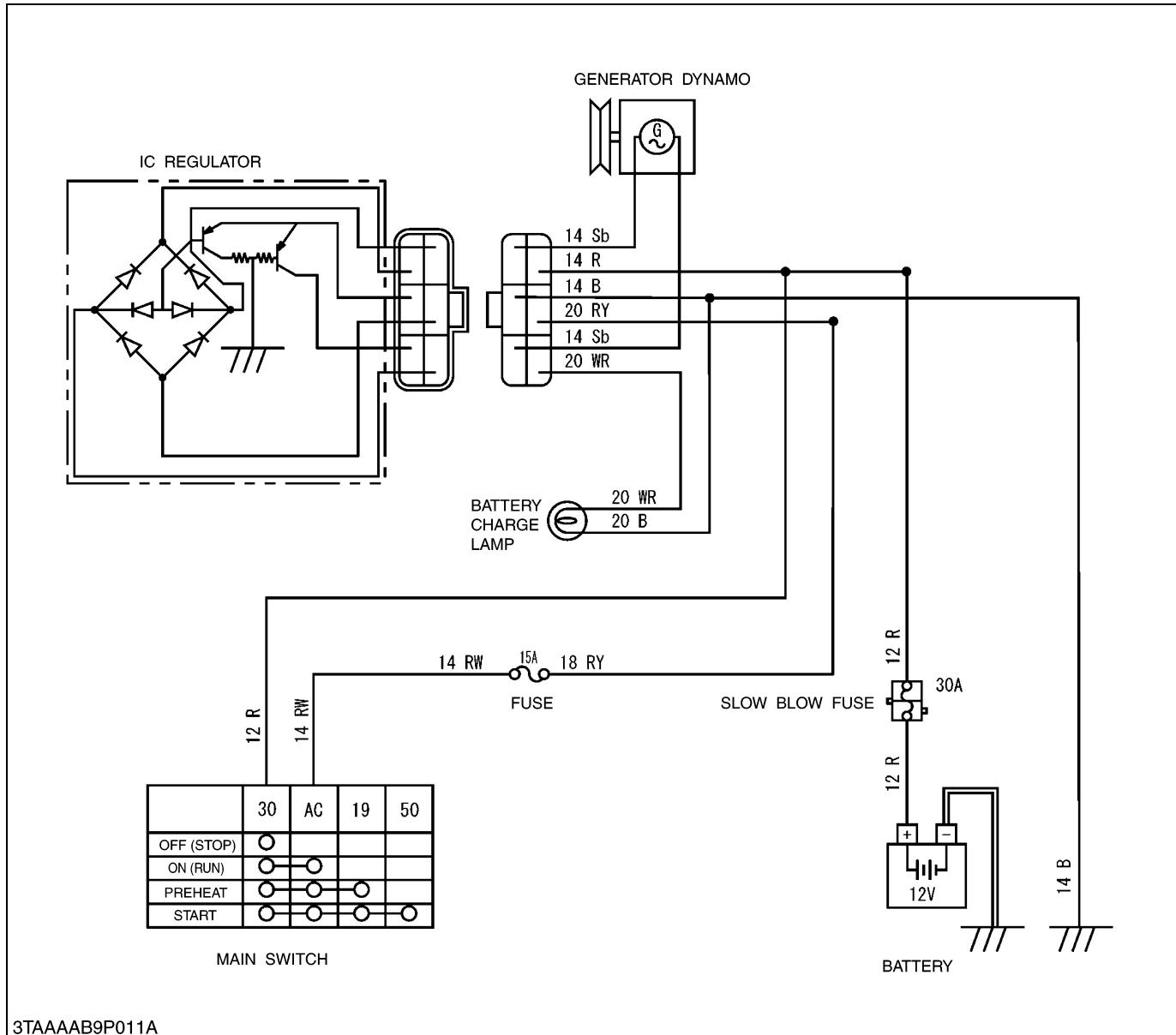

3TAAAAB9P011A

The charging system supplies electric power for various electrical devices and also charges the battery while the engine runs.

It consists of a AC dynamo and a regulator.

[1] AC DYNAMO

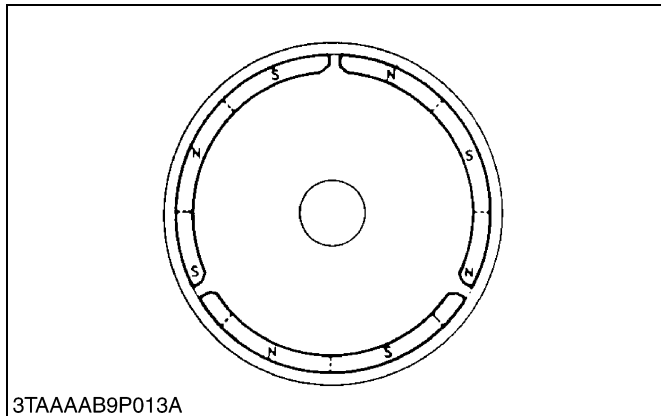
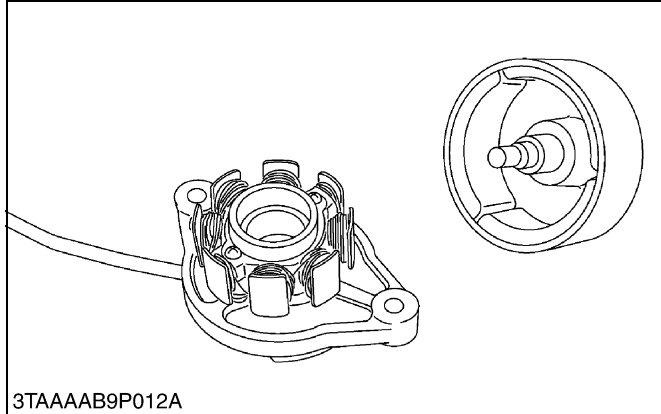

The dynamo is an 8-8 pole rotating magnet type generator. It is simple in construction, consisting of a stator and rotor. The rotor is made up of eight permanent magnet pole pieces assembled on a shaft and rotates on the center of the stator around which eight electromagnetic coils are provided for.

This dynamo produces higher voltage in slow speed rotation, and charges electric current to the battery during engine idling.

W1013535

[2] REGULATOR

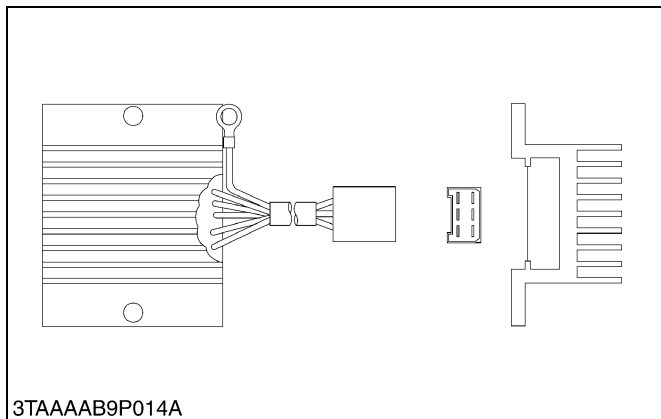

The regulator performs rectification and voltage regulation.

The regulator converts AC into DC which flows through the power consuming circuits and the battery, and also charges the battery.

If however, the battery voltage exceeds a certain level, the DC current is cut off from the charging circuit to prevent overcharging.

W1013678

[1] HEAD LIGHT

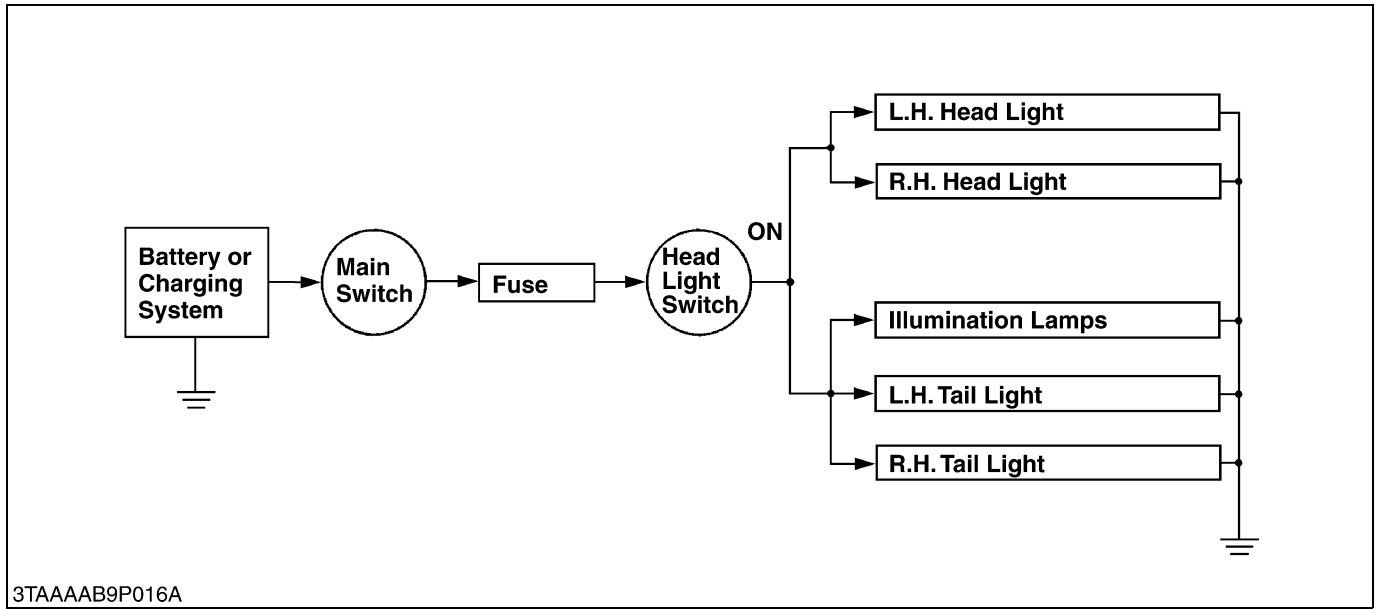

The head light switch has two positions; **OFF** and **ON**.

Current passes through the light circuit as shown in the figure above.

[2] TURN SIGNAL LIGHT

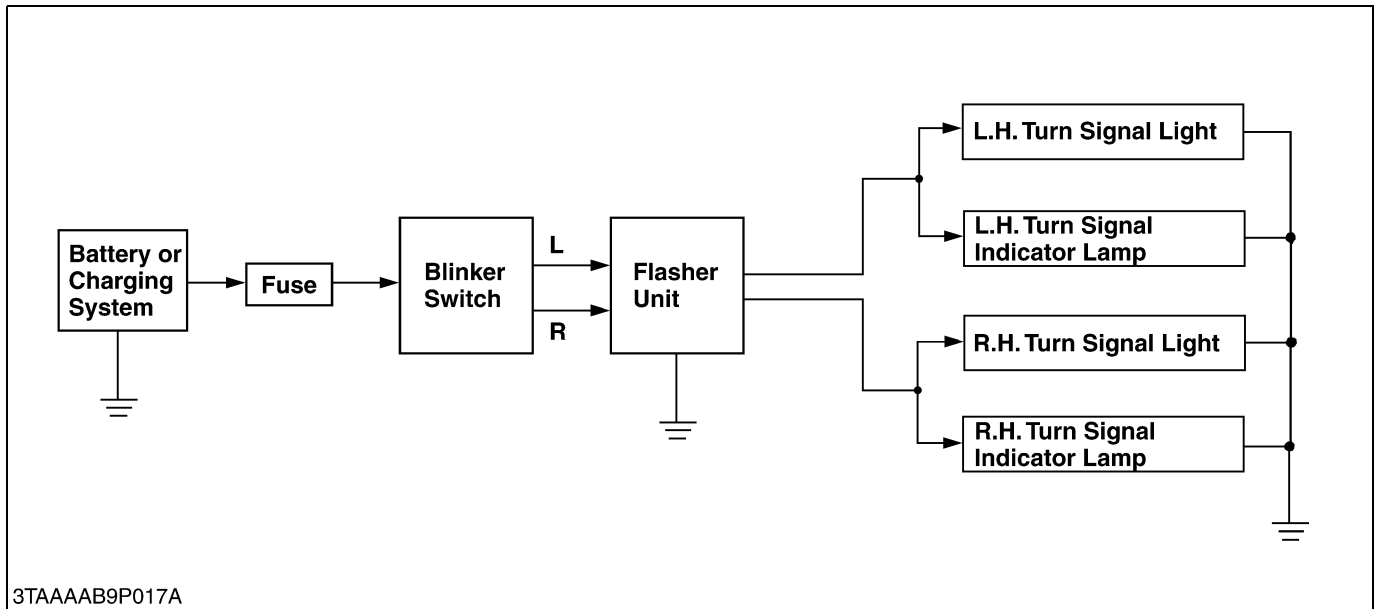

The blinker switch has three positions; **OFF**, **L** and **R**. When using blinker switch, blinks only one side light and other one stays on.

[3] HAZARD LIGHT

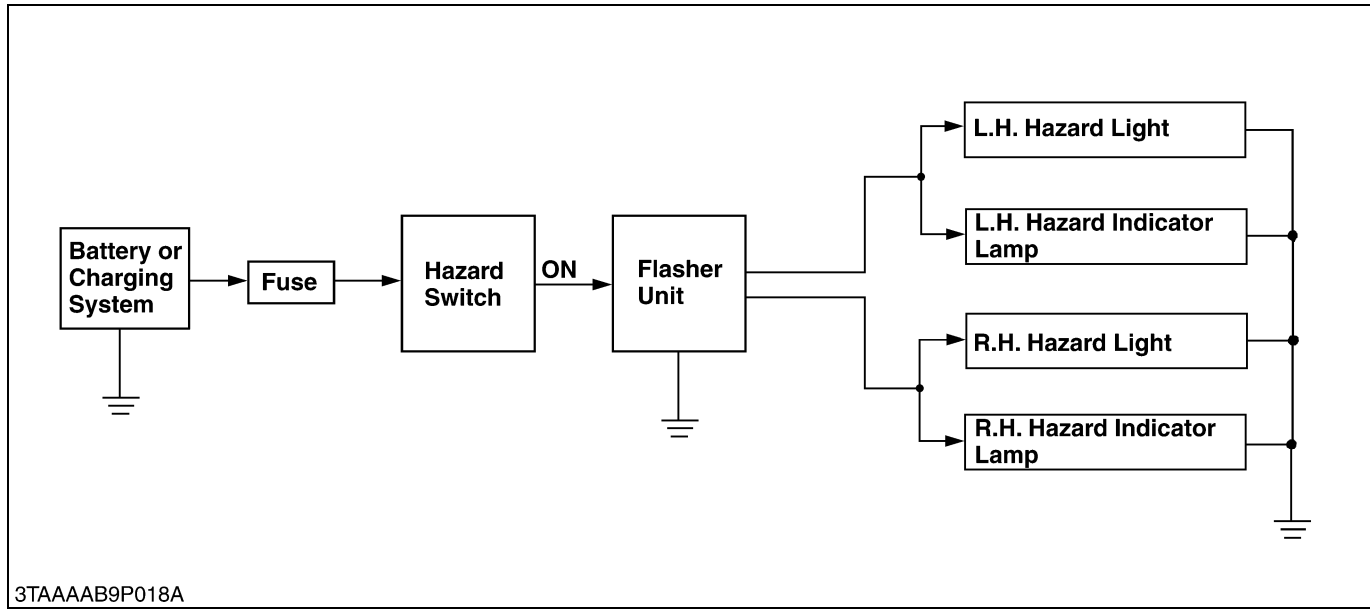

3TAAAB9P018A

Hazard switch has two positions; **ON** and **OFF**. Blinking the hazard lights and indicator lamps as shown in the figure above.

[4] EASY CHECKER

To check the conditions of tractor easily before and during operation, easy checker combination of lamps on the easy checker board is provided.

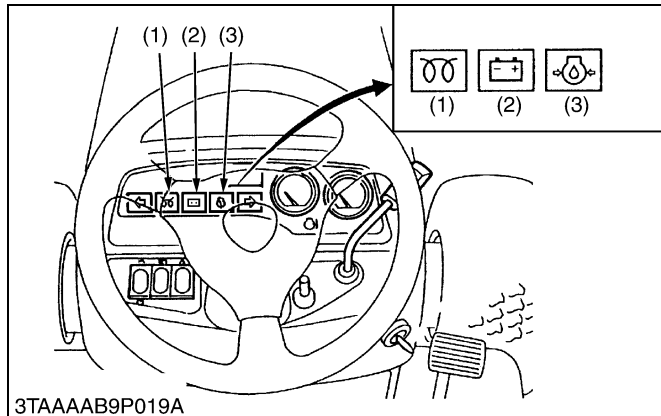

3TAAAB9P019A

■ Indication Items

(1) Pre-heat Indicator Lamp

When the key switch is in the “**Pre-heat**” position, the pre-heat indicator lamp illuminates.

(2) Charge Lamp

When the charging system is not functioning properly, this lamp illuminates.

(3) Oil Pressure Lamp

When the engine oil pressure is low, this lamp illuminates.

W1013386

■ Oil Pressure Switch

While oil pressure is high and the force applied to the diaphragm (2) is larger than the spring tension, the terminal contact (1) is open separated from the body contact (3). If the pressure drops below approx. 49 kPa (0.5 kgf/cm², 7.1 psi), the contact closes.

(1) Terminal Contact

(3) Body Contact

(2) Diaphragm

W1016053

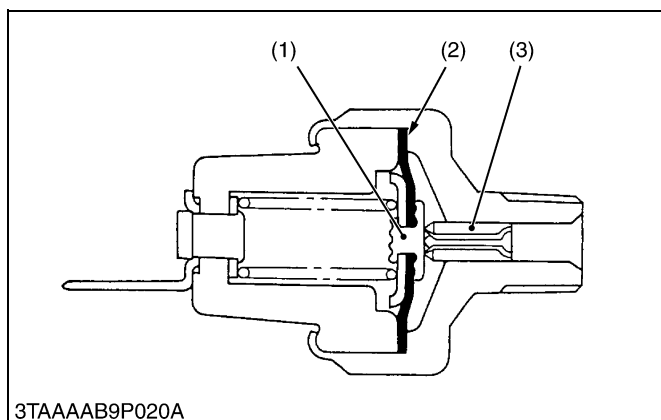

3TAAAB9P020A

5. GAUGES

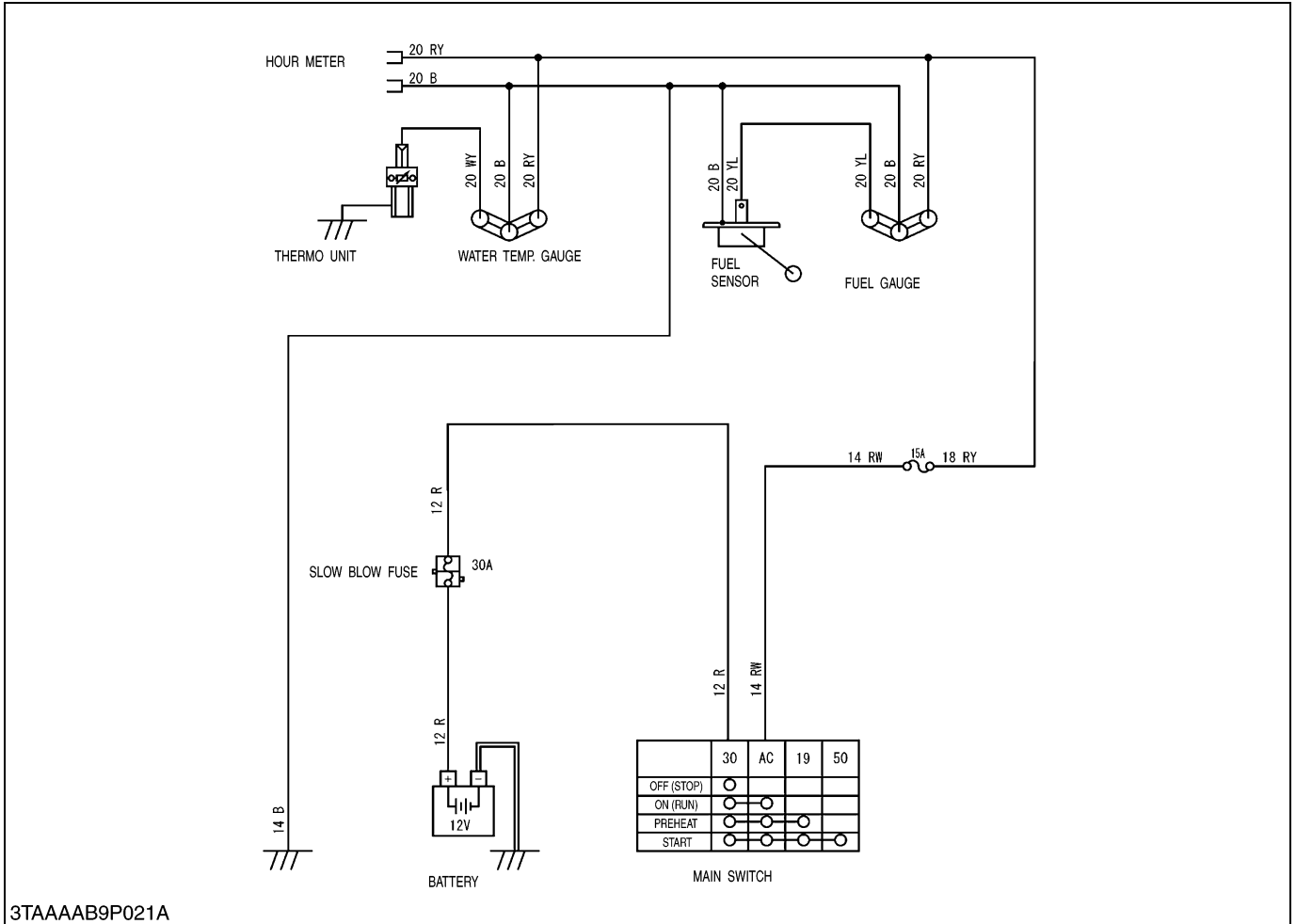

3TAAAAB9P021A

The fuel quantity and coolant temperature are indicated by the ammeters. The ammeters indicate each amperage flowing through the fuel level sensor for the fuel quantity detection and through the coolant temperature sensor for the coolant temperature detection.

[1] FUEL QUANTITY

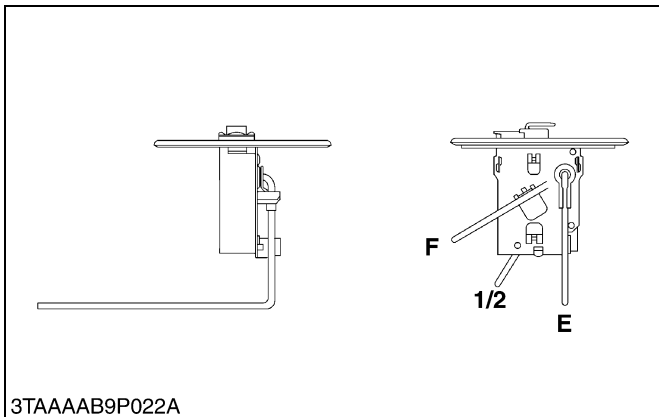

3TAAAAB9P022A

■ Fuel Level Sensor

The remaining fuel quantity is detected by the fuel level sensor installed in the fuel tank and indicated on the fuel gauge. For detection, a float and a resistor are used.

As the float lowers, the resistance of the variable resistor varies. The relation between the amount of fuel and the resistance is as follows.

F	1/2	E (Remaining fuel of approx. 5.0 L, 1.32 U.S.gal., 1.10 Imp.gal.)
1 to 5 Ω	28.5 to 36.5 Ω	103 to 117 Ω

W1013985

[2] COOLANT TEMPERATURE

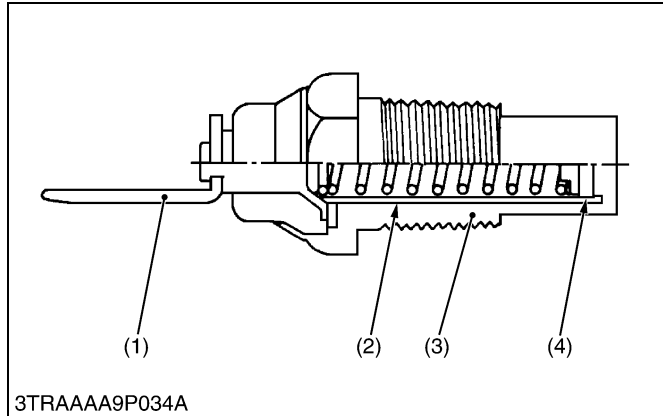

■ Coolant Temperature Sensor

The coolant temperature sensor is installed to the cylinder head of engine, and its tip is in touch with the coolant. It contains a thermistor (4) whose electrical resistance decreases as the temperature increases.

Current varies with changes in the coolant temperature, and the increases or decreases in the current move the pointer of gauge.

Characteristics of Thermistor	
Temperature	Resistance
50 °C (122 °F)	153.9 Ω
80 °C (176 °F)	51.9 Ω
100 °C (212 °F)	27.4 Ω
120 °C (248 °F)	16.1 Ω

(1) Terminal
(2) Insulator

(3) Body
(4) Thermistor

W1016720

SERVICING

CONTENTS

1. TROUBLESHOOTING	6-S1
2. SERVICING SPECIFICATIONS	6-S4
3. TIGHTENING TORQUES	6-S5
4. CHECKING, DISASSEMBLING AND SERVICING.....	6-S6
[1] BATTERY.....	6-S6
(1) Checking.....	6-S6
[2] STARTING SYSTEM	6-S7
(1) Checking.....	6-S7
(2) Disassembling and Assembling	6-S13
(3) Servicing	6-S13
[3] CHARGING SYSTEM.....	6-S16
(1) Checking.....	6-S16
(2) Disassembling and Assembling	6-S16
(3) Servicing	6-S17
[4] LIGHTING SYSTEM	6-S17
(1) Checking.....	6-S17
[5] GAUGES.....	6-S20
(1) Checking.....	6-S20

1. TROUBLESHOOTING

Symptom	Probable Cause	Solution	Reference Page
All Electrical Equipments Do Not Operate	• Battery discharged or defective	Recharge or replace	G-16, 2-S13
	• Battery positive cable disconnected or improperly connected	Repair or replace	–
	• Battery negative cable disconnected or improperly connected	Repair or replace	–
	• Slow blow fuse blown	Replace	–
Fuse Blown Frequently	• Short-circuited	Repair or replace	–

W10143220

BATTERY

Battery Discharges Too Quickly	• Battery defective	Replace	2-S13
	• Dynamo defective	Repair or replace	6-S16
	• IC Regulator defective	Replace	–
	• Wiring harness disconnected or improperly connected (between battery positive terminal and regulator B terminal)	Repair or replace	–
	• Cooling fan belt slipping	Adjust tension	G-18

W10137180

STARTING SYSTEM

Starter Motor Does Not Operate	• Battery discharged or defective	Recharge or replace	G-16, 2-S13
	• Slow blow fuse blown	Replace	–
	• Safety switch improperly adjusted or defective	Repair or replace	6-S10
	• Wiring harness disconnected or improperly connected (between main switch 50 terminal and safety switches, between safety switches and starter motor, between battery positive terminal and starter motor)	Repair or replace	–
	• Starter motor defective	Repair or replace	6-S13
Engine Does Not Stop When Main Switch is Turned OFF	• Main switch defective	Replace	6-S7
	• Fuse blown (20 A)	Replace	G-26
	• Wiring harness disconnected or improperly connected (between main switch AC terminal and engine stop solenoid)	Repair or replace	–
	• Engine stop solenoid defective	Replace	6-S11
Engine Does Not Start	• Timer relay defective	Replace	6-S12
	• Engine stop solenoid defective	Replace	6-S11
	• Timer relay defective	Replace	6-S12

W10137180

CHARGING SYSTEM

Symptom	Probable Cause	Solution	Reference Page
Charging Lamp Does Not Light when Main Switch is Turned ON	<ul style="list-style-type: none"> • Fuse blown (15 A) • Wiring harness disconnected or improperly connected (between main switch AC terminal and panel board, between panel board and dynamo) 	Replace	G-26
		Repair or Replace	–
Charging Lamp Does Not Go Off When Engine is Running	<ul style="list-style-type: none"> • Dynamo defective • Regulator defective 	Repair or Replace	6-S16
		Replace	–
Charging Lamp Does Not Go Off When Engine is Running	<ul style="list-style-type: none"> • Wiring harness disconnected or improperly connected (between main switch 30 terminal and dynamo, between panel board and dynamo) 	Repair or Replace	–
		<ul style="list-style-type: none"> • Dynamo defective • Regulator defective 	6-S16
		Replace	–

W10135800

LIGHTING SYSTEM

Head Light Does Not Light	<ul style="list-style-type: none"> • Fuse blown (15 A) • Bulb blown • Wiring harness disconnected or improperly connected (between main switch AC terminal and head light switch, between head light switch and head light) 	Replace Replace Repair or Replace	G-26 G-26 –
Tail Light Does Not Light	<ul style="list-style-type: none"> • Fuse blown (15 A) • Bulb blown • Wiring harness disconnected or improperly connected (between main switch AC terminal and head light switch, between head light switch and tail light) 	Replace Replace Repair or Replace	G-26 G-26 –
Illumination Light Does Not Light	<ul style="list-style-type: none"> • Fuse blown (15 A) • Bulb blown • Wiring harness disconnected or improperly connected (between main switch AC terminal and head light switch, between head light switch and illumination light) 	Replace Replace Repair or Replace	G-26 G-26 –
Hazard Light Does Not Light	<ul style="list-style-type: none"> • Fuse blown (15 A) • Bulb blown • Wiring harness disconnected or improperly connected 	Replace Replace Repair or Replace	G-26 G-26 –
		<ul style="list-style-type: none"> • Flasher unit defective • Hazard switch defective 	Replace Replace
Hazard Indicator Lamp Does Not Light	<ul style="list-style-type: none"> • Bulb blown • Wiring harness disconnected or improperly connected 	Replace Repair or Replace	– –
Hazard Light Does Not Flicker	<ul style="list-style-type: none"> • Flasher unit defective 	Replace	6-S18

W10137180

LIGHTING SYSTEM (Continued)

Symptom	Probable Cause	Solution	Reference Page
Turn Signal Light Does Not Light	<ul style="list-style-type: none"> • Fuse blown (15 A) • Bulb blown • Wiring harness disconnected or improperly connected • Flasher unit defective • Blinker switch defective 	Replace Replace Repair or Replace Replace Replace	G-26 G-26 – 6-S18 6-S17
Turn Signal Light Indicator Lamp Does Not Light	<ul style="list-style-type: none"> • Bulb blown • Wiring harness disconnected or improperly connected (blinker switch and indicator lamp) 	Replace Repair or Replace	G-26 –
Turn Signal Light Does Not Flicker	<ul style="list-style-type: none"> • Flasher unit defective • Blinker switch defective 	Replace Replace	6-S18 6-S17
Pre-heat Indicator Lamp Does Not Light When Main Switch Is in Pre-heat Position	<ul style="list-style-type: none"> • Battery discharged or defective • Slow blow fuse blown • Wiring harness disconnected or improperly connected (between main switch 19 terminal and pre-heat indicator, between pre-heat indicator and glow plugs) • Main switch defective • Pre-heat indicator defective 	Recharge or Replace Replace Repair or Replace Replace Replace	G-16, 2-S13 G-26 – – –
Oil Pressure Lamp Lights Up When Engine Is Running	<ul style="list-style-type: none"> • Engine oil pressure too low • Engine oil insufficient • Oil pressure switch defective • Short circuit between oil pressure switch lead and chassis 	Repair engine Replenish Replace Repair	– G-12 6-S19 –
Oil Pressure Lamp Does Not Light When Main Switch Is Turned ON and Engine Is Not Running	<ul style="list-style-type: none"> • Bulb blown • Oil pressure switch defective • Wiring harness disconnected or improperly connected (between panel board and oil pressure switch) 	Replace Replace Repair or Replace	G-26 6-S19 –

W10135800

GAUGES

Fuel Gauge Does Not Function	<ul style="list-style-type: none"> • Fuel gauge defective • Fuel level sensor defective • Wiring harness disconnected or improperly connected (between fuel gauge and fuel level sensor) 	Replace Replace Repair or Replace	6-S20 6-S20 –
Coolant Temperature Gauge Does Not Function	<ul style="list-style-type: none"> • Coolant temperature gauge defective • Coolant temperature sensor defective • Wiring harness disconnected or improperly connected (between coolant temperature gauge and coolant temperature sensor) 	Replace Replace Repair or Replace	6-S20 6-S20 –

W10137180

2. SERVICING SPECIFICATIONS

Item		Factory Specification	Allowable Limit	
Battery	Voltage	More than 12 V	–	
	Potential Difference	Less than 0.1 V	–	
Glow Plug	Resistance	Approx. 0.9 Ω	–	
Safety Switch	Distance	3 to 5 mm 0.118 to 0.197 in.	–	
Starter	Commutator	O.D.	30.0 mm 1.181 in.	29.0 mm 1.142 in.
		Difference of O.D.'s	Less than 0.02 mm 0.0008 in.	0.05 mm 0.0020 in.
	Mica	Undercut	0.50 to 0.80 mm 0.0197 to 0.0315 in.	0.20 mm 0.0079 in.
	Brush	Length	14.0 mm 0.551 in.	9.0 mm 0.354 in.
AC Dynamo	Charging Current / Dynamo Speed	14 to 15 A / 5200 min ⁻¹ (rpm)	–	
	Charging Voltage / Dynamo Speed	14 to 15 A / 5200 min ⁻¹ (rpm)	–	
Head Light Switch	Resistance OFF	Infinity	–	
	ON	0 Ω	–	
Blinker Switch	Resistance OFF	Infinity	–	
	R	0 Ω	–	
	L	0 Ω	–	
Hazard Light Switch	Resistance OFF	Infinity	–	
	ON	0 Ω	–	

W10138740

3. TIGHTENING TORQUES

Tightening torques of screws, bolts and nuts on the table below are especially specified.
(For general use screws, bolts and nuts : See page G-8.)

Item	N·m	kgf·m	ft-lbs
Starter B terminal nut	5.9 to 11.8	0.6 to 1.2	4.3 to 8.7
AC Dynamo Stator nut	39.2 to 44.1	4.0 to 4.5	28.9 to 32.5

W10127360

4. CHECKING, DISASSEMBLING AND SERVICING

CAUTION

- To avoid accidental short circuit, be sure to attach the positive cable to the positive terminal before the negative cable is attached to the negative terminal.
- Never remove the battery cap while the engine is running.
- Keep electrolyte away from eyes, hands and clothes. If you are splattered with it, wash it away completely with water immediately.
- Keep open sparks and flames away from the battery at all times. Hydrogen gas mixed with oxygen becomes very explosive.

■ IMPORTANT

- If the machine is to be operated for a short time without battery (using a slave battery for starting), use additional current (lights) while engine is running and insulate terminal of battery. If this advice is disregarded, damage to alternator and regulator may result.

[1] BATTERY

(1) Checking

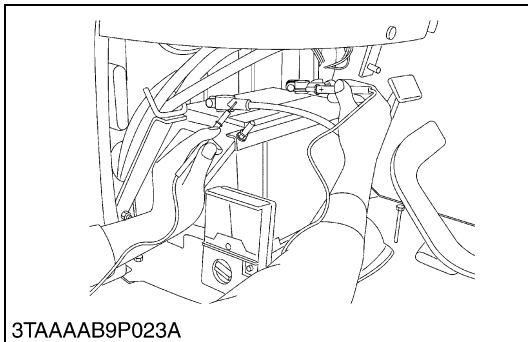

Battery Voltage

1. Stop the engine and turn the main switch off.
2. Connect the COM (-) lead of the voltmeter to the battery's negative terminal post and the (+) lead to the positive terminal post, and measure the battery voltage.
3. If the battery voltage is less than the factory specification, check the battery specific gravity and recharge the battery.

Battery voltage	Factory spec.	More than 12 V
-----------------	---------------	----------------

W10125620

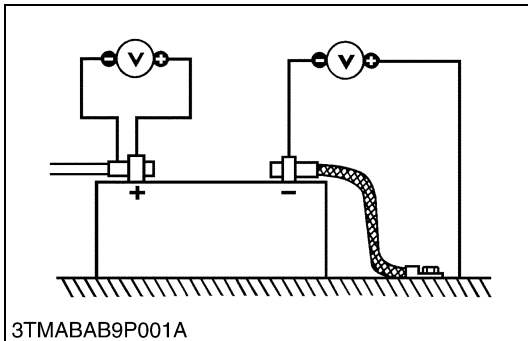

Battery Terminal Connection

1. Turn the main switch on, and turn on the head light.
2. Measure the voltage with a voltmeter across the battery's positive terminal post and the cable terminal, and the voltage across the battery's negative terminal post and the chassis.
3. If the measurement exceeds the factory specification, clean the battery terminal posts and cable clamps, and tighten them firmly.

Potential difference	Factory spec.	Less than 0.1 V
----------------------	---------------	-----------------

W10126630

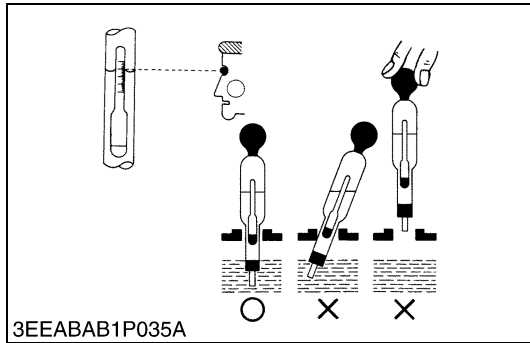
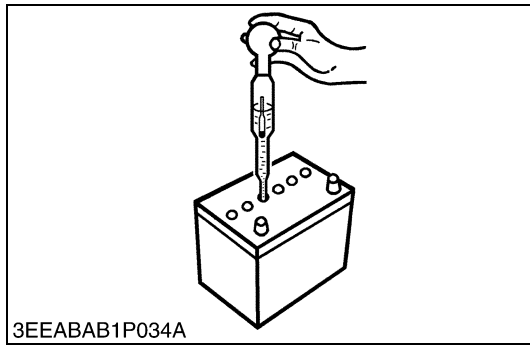

Battery Specific Gravity

1. Check the specific gravity of the electrolyte in each cell with a hydrometer.
2. When the electrolyte temperature differs from that at which the hydrometer was calibrated, correct the specific gravity reading following the formula mentioned in **(Reference)**.
3. If the specific gravity is less than 1.215 (after it is corrected for temperature), charge or replace the battery.
4. If the specific gravity differs between any two cells by more than 0.05, replace the battery.

NOTE

- **HOLD the hydrometer tube vertical without removing it from the electrolyte.**
- **Do not suck too much electrolyte into the tube.**
- **Allow the float to move freely and hold the hydrometer at eye level.**
- **The hydrometer reading must be taken at the highest electrolyte level.**

(Reference)

- Specific gravity slightly varies with temperature. To be exact, the specific gravity decreases by 0.0007 with an increase of 1 °C (0.0004 with an increase of 1 °F) in temperature, and increases by 0.0007 with a decreases of 1 °C (0.0004 with a decrease of 1 °F).

Therefore, using 20 °C (68 °F) as a reference, the specific gravity reading must be corrected by the following formula :

- Specific gravity at 20 °C = Measured value + 0.0007 × (electrolyte temperature – 20 °C)
- Specific gravity at 68 °F = Measured value + 0.0004 × (electrolyte temperature – 68 °F)

Specific Gravity	State of Charge
1.260 Sp. Gr.	100 % Charged
1.230 Sp. Gr.	75 % Charged
1.200 Sp. Gr.	50 % Charged
1.170 Sp. Gr.	25 % Charged
1.140 Sp. Gr.	Very Little Useful Capacity
1.110 Sp. Gr.	Discharged

At an electrolyte temperature of 20 °C (68 °F)

W10127630

[2] STARTING SYSTEM

(1) Checking

(A) Main Switch

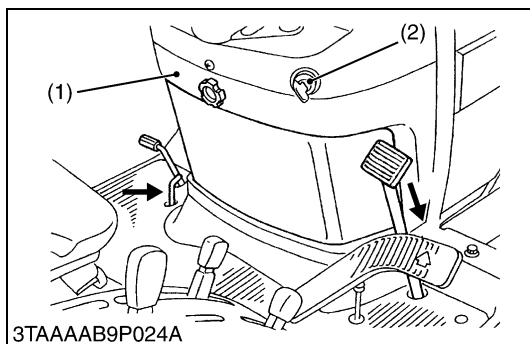

Main Switch

1. Remove the under panel (1).
2. Disconnect the **4P** connector and remove the main switch (2).
3. Perform the following checks.

(1) Under Panel

(2) Main Switch

W10134520

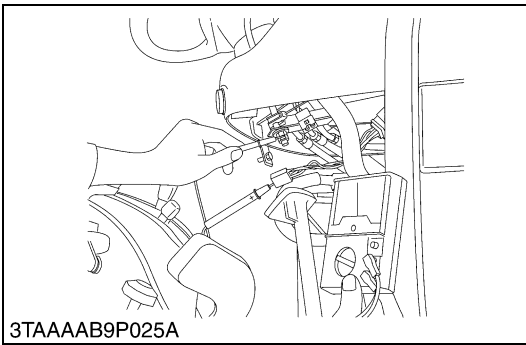

3TAAAAB9P025A

Connector Voltage

1. Measure the voltage with a voltmeter across the connector **30** (red) terminal and chassis.
2. If the voltage differs from the battery voltage (11 to 14 V), the wiring harness is faulty.

Voltage	Connector 30 terminal – chassis	Approx. battery voltage
---------	--	-------------------------

W10135530

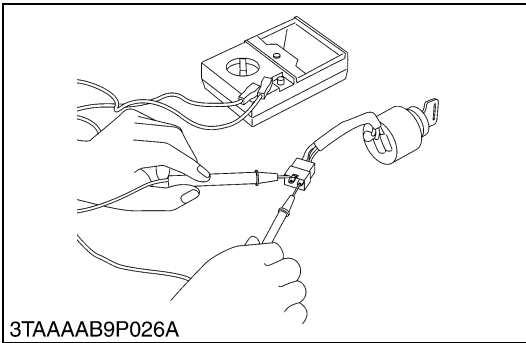

3TAAAAB9P026A

Main Switch Continuity

1) Main Switch Key at OFF Position

1. Set the main switch **OFF** position.
2. Measure the resistance with an ohmmeter across the **30** terminal and the **AC** terminal, **30** terminal and **50** terminal, **30** terminal and **19** terminal.
3. If infinity is not indicated, the contacts of the main switch are faulty.

Resistance	30 terminal – AC terminal	Infinity
	30 terminal – 50 terminal	
	30 terminal – 19 terminal	

2) Main Switch Key at ON Position

1. Set the main switch **ON** position.
2. Measure the resistance with an ohmmeter across the **30** terminal and the **AC** terminal.
3. If 0 ohm is not indicated, the **30** – **AC** contact of the main switch are faulty.

Resistance	30 terminal – AC terminal	0 Ω
------------	---	-----

3) Main Switch Key at PREHEAT Position

1. Set and hold the main switch key at the **PREHEAT** position.
2. Measure the resistance with an ohmmeter across the **30** terminal and the **19** terminal, and measure the resistance across the **30** terminal and the **AC** terminal.
3. If 0 ohm is not indicated, these contacts of the main switch are faulty.

Resistance	30 terminal – 19 terminal	0 Ω
	30 terminal – AC terminal	

4) Main Switch Key at START Position

1. Set and hold the main switch key at the **START** position.
2. Measure the resistance with an ohmmeter across the **30** terminal and the **19** terminal, across the **30** terminal and the **50** terminal, and across the **30** terminal and the **AC** terminal.
3. If 0 ohm is not indicated, these contacts of the main switch are faulty.

Resistance	30 terminal – 19 terminal	0 Ω
	30 terminal – 50 terminal	
	30 terminal – AC terminal	

- (1) **19** Terminal (Black / Red) (3) **50** Terminal (Black / White)
 (2) **AC** Terminal (Red / White) (4) **30** Terminal (Red)

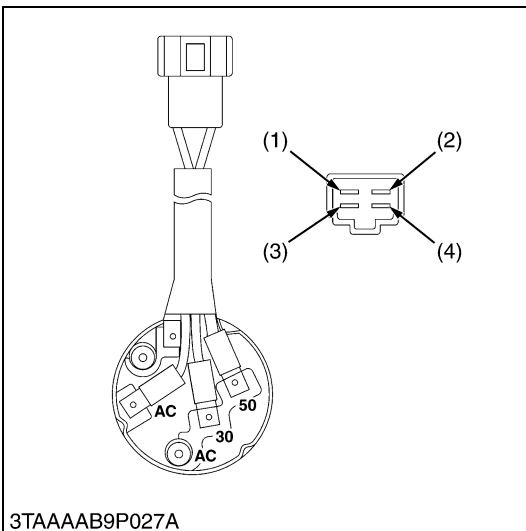

3TAAAAB9P027A

W10136580

(B) Starter

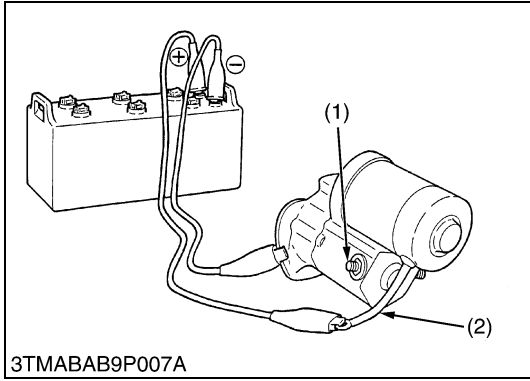

Motor Test



- **Secure the starter to prevent it from jumping up and down while testing the motor.**
1. Disconnect the battery negative cable from the battery.
 2. Disconnect the battery positive cable and the leads from the starter.
 3. Remove the starter from the engine.
 4. Disconnect the connecting lead (2) from the starter **C** terminal (1).
 5. Connect a jumper lead from the connecting lead (2) to the battery positive terminal post.
 6. Connect a jumper lead momentarily between the starter motor housing and the battery negative terminal post.
 7. If the motor does not run, check the motor.

(1) C Terminal (2) Connecting Lead

W10142670

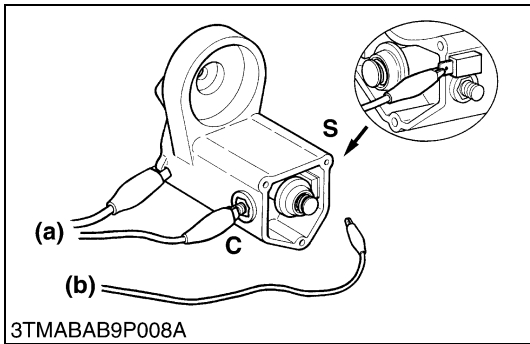

Magnet Switch Test (Pull-in, Holding Coils)

1. Remove the motor from the starter housing.
2. Prepare a 6 V battery for the test.
3. Connect jumper leads from the battery negative terminal to the housing and the starter **C** terminal.
4. The plunger should be attracted and the pinion gear should pop out when a jumper lead is connected from the battery positive terminal to the **S** terminal. It's a correct.
5. Disconnect the jumper lead to the starter **C** terminal. Then the pinion gear should remain popped out. It's a correct.

IMPORTANT

- **Testing time must be 3 to 5 sec..**

C : C Terminal (a) To Negative Terminal
S : S Terminal (b) To Positive Terminal

W1015210

(C) Glow Plug

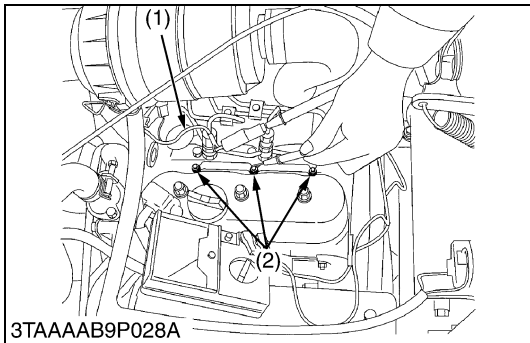

Lead Terminal Voltage

1. Disconnect the wiring lead (1) from the glow plug (2) after turning the main switch off.
2. Turn the main switch key to the "**PREHEAT**" position, and measure the voltage between the lead terminal and the chassis.
3. Turn the main switch key to the "**START**" position, and measure the voltage with a voltmeter between the lead terminal and the chassis.
4. If the voltage at either position differs from the battery voltage, the wiring harness or main switch is faulty.

Voltage (Lead terminal – Chassis)	Main switch key at " PREHEAT "	Approx. battery voltage
	Main switch key at " START "	Approx. battery voltage

(1) Wiring Lead (Positive) (2) Glow Plug

W10149130

(E) Fuel Pump

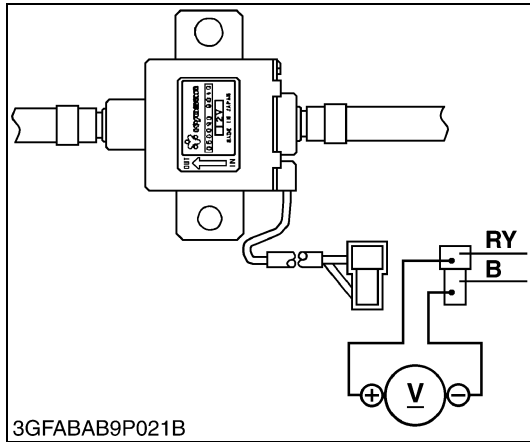

Connector Voltage

1. Disconnect the **2P** connector from the fuel pump.
2. Turn the main switch key to the “**ON**” position, and measure the voltage with a voltmeter between the connector terminals.
3. If the voltage differs from the battery voltage, the wiring harness or main switch is faulty.

Voltage	Between connector terminals	Approx. battery voltage
---------	-----------------------------	-------------------------

W1016341

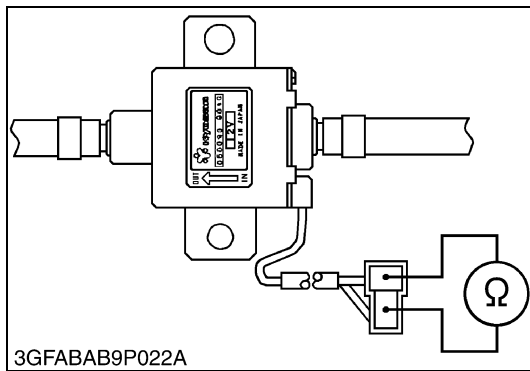

Fuel Pump Continuity

1. Disconnect the **2P** connector from the fuel pump.
2. Check the continuity between the connector terminals with an ohmmeter.
3. If it does not conduct, the fuel pump is faulty.

W1016134

(F) Engine Stop Solenoid

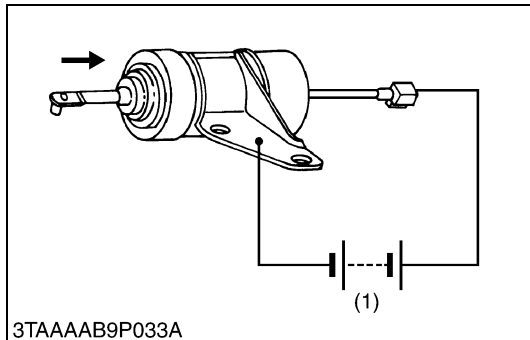

Engine Stop Solenoid Test (D722)

1. Disconnect the **1P** connector from the engine stop solenoid.
2. Remove the engine stop solenoid from the engine.
3. Connect the jumper leads from the battery positive terminal to the **1P** connector, and from the battery negative terminal to the engine stop solenoid body.
4. If the solenoid plunger is not attracted, the engine stop solenoid is faulty.

(1) Battery (12 V)

W1019658

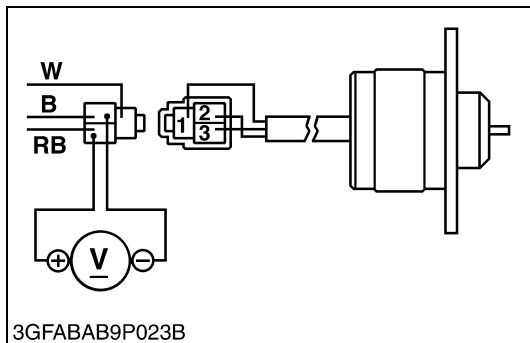

Connector Voltage (D905)

1. Disconnect the **3P** connector from the engine stop solenoid.
2. Turn the main switch key to the “**ON**” position, and measure the voltage with a voltmeter between the terminal **3** (Red / Black) and the terminal **2** (Black).
3. If the voltage differs from the battery voltage, the wiring harness or main switch is faulty.

Voltage	Terminal 3 - Terminal 2	Approx. battery voltage
---------	---------------------------------------	-------------------------

W1016508

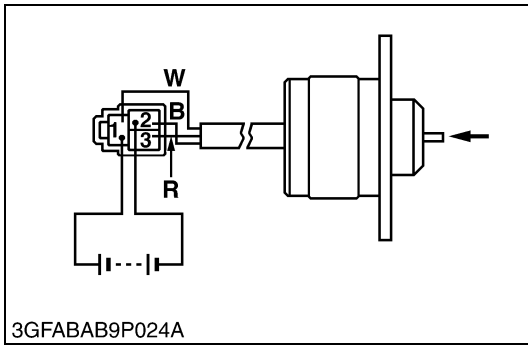

Engine Stop Solenoid Test (D905)

1. Disconnect the **3P** connector from the engine stop solenoid.
2. Remove the engine stop solenoid from the engine.
3. Connect the jumper leads from the battery positive terminal to the terminal **1** (White), and from the battery negative terminal to the terminal **2** (Black).
4. If the solenoid plunger is not attracted, the engine stop solenoid is faulty.
5. Connect the jumper leads from the battery positive terminal to the terminal **3** (Red), and from the battery negative terminal to the terminal **2** (Black).
Push the solenoid plunger in by your finger, and then release it.
6. If the solenoid plunger is not held, the engine stop solenoid is faulty.

W1016653

(G) Timer Relay (D722)

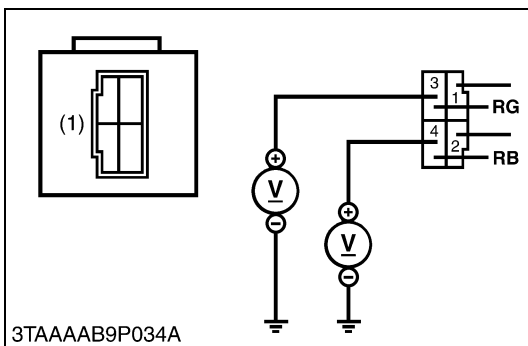

Timer Relay Connector Voltage

1. Disconnect the connector from the timer relay after turning the main switch off.
2. Measure the voltage with a voltmeter across the connector terminal **4** and chassis.
3. Turn the main switch on, and measure the voltage across the connector terminal **3** and chassis.
4. If these voltages differ from the battery voltage, the wiring harness or main switch is faulty.

Voltage	Connector terminal 4 -chassis	Approx. battery voltage
	Connector terminal 3 -chassis	Approx. battery voltage

(1) Timer Relay

W1016544

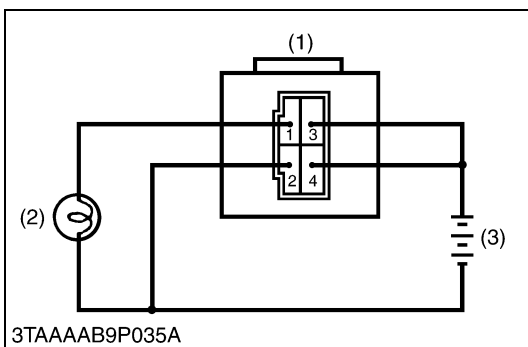

Test of Timer Relay

1. Remove the timer relay from the tractor.
2. Connect jumper leads across the battery positive terminal and the timer relay terminal **3**, and across the battery positive terminal and the timer relay terminal **4**.
3. Connect jumper leads across the battery negative terminal and the timer relay terminal **2**, and across the battery negative terminal and the bulb terminal.
4. Connect jumper lead across the timer relay terminal **1** and the bulb terminal.
5. The bulb lights up when disconnecting a jumper lead from the terminal **3** and goes off 6 to 13 seconds late, the timer relay is proper.

(1) Timer Relay
(2) Load (Lamp)

(3) Battery (12V)

W1016721

(2) Disassembling and Assembling

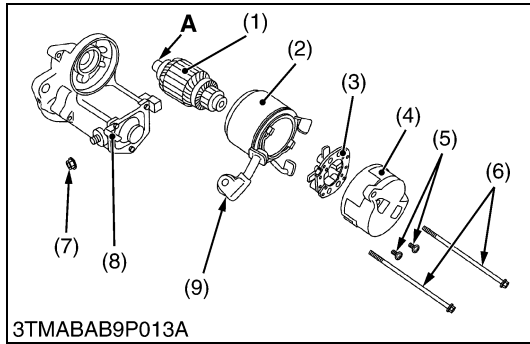

3TMABAB9P013A

Disassembling Motor

1. Disconnect the connecting lead (9) from the magnet switch (8).
2. Remove the screws (6), and then separate the end frame (4), yoke (2) and armature (1).
3. Remove the two screws (5), and then take out the brush holder (3) from the end frame (4).

(When reassembling)

- Apply grease to the spline teeth (A) of the armature (1).

Tightening torque	Nut (7)	5.9 to 11.8 N·m 0.6 to 1.2 kgf·m 4.3 to 8.7 ft·lbs
-------------------	---------	--

- | | |
|------------------|-------------------------|
| (1) Armature | (7) Nut |
| (2) Yoke | (8) Magnet Switch |
| (3) Brush Holder | (9) Connecting Lead |
| (4) End Frame | |
| (5) Screw | A : Spline Teeth |
| (6) Screw | |

W1016288

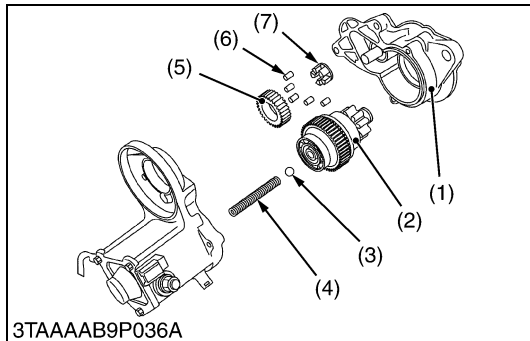

3TAAAAB9P036A

Disassembling Magnet Switch

1. Remove the drive end frame (1) mounting screws.
2. Take out the overrunning clutch (2), ball (3), spring (4), gears (5), rollers (6) and retainer (7).

(When reassembling)

- Apply grease to the gear teeth of the gears (5) and overrunning clutch (2), and ball (3).

- | | |
|------------------------|--------------|
| (1) Drive End Frame | (5) Gear |
| (2) Overrunning Clutch | (6) Roller |
| (3) Ball | (7) Retainer |
| (4) Spring | |

W1016728

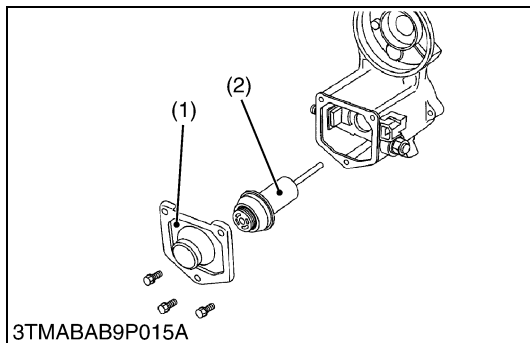

3TMABAB9P015A

Plunger

1. Remove the end cover (1).
2. Take out the plunger (2).

- | | |
|---------------|-------------|
| (1) End Cover | (2) Plunger |
|---------------|-------------|

W1016883

(3) Servicing

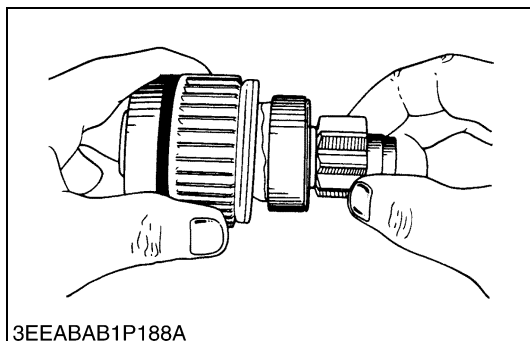

3EEABAB1P188A

Overrunning Clutch

1. Inspect the pinion for wear or damage.
2. If there is any defect, replace the overrunning clutch assembly.
3. Check that the pinion turns freely and smoothly in the overrunning direction and does not slip in the cranking direction.
4. If the pinion slips or does not rotate in the both directions, replace the overrunning clutch assembly.

W1016990

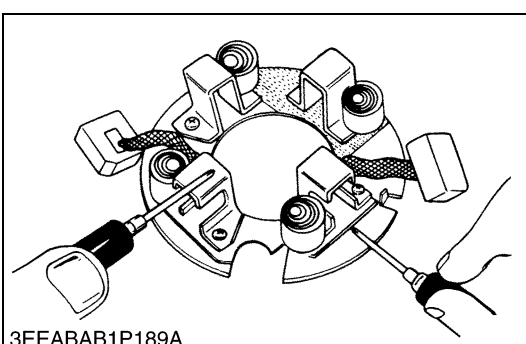
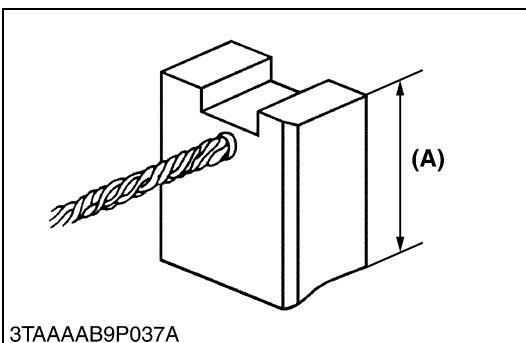
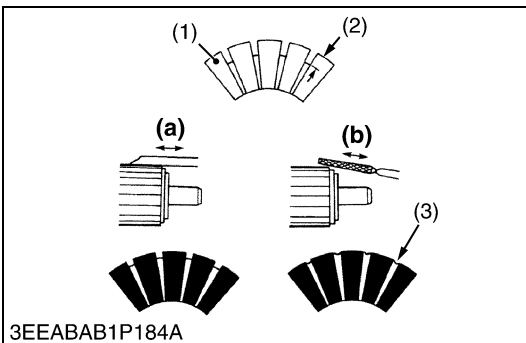
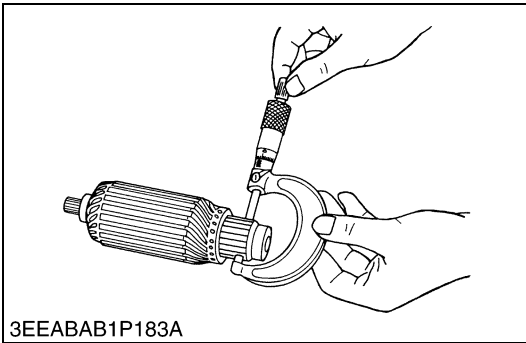
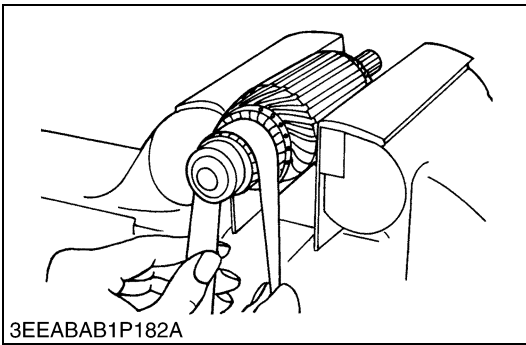

Commutator and Mica

1. Check the contact face of the commutator for wear, and grind the commutator with emery paper if it is slightly worn.
2. Measure the commutator O.D. with an outside micrometer at several points.
3. If the minimum O.D. is less than the allowable limit, replace the armature.
4. If the difference of the O.D.'s exceeds the allowable limit, correct the commutator on a lathe to the factory specification.
5. Measure the mica undercut.
6. If the undercut is less than the allowable limit, correct it with a saw blade and chamfer the segment edges.

Commutator O.D.	Factory spec.	30.0 mm 1.181 in.
	Allowable limit	29.0 mm 1.142 in.

Difference of O.D.'s	Factory spec.	Less than 0.02 mm 0.0008 in.
	Allowable limit	0.05 mm 0.0020 in.

Mica undercut	Factory spec.	0.50 to 0.80 mm 0.0197 to 0.0315 in.
	Allowable limit	0.20 mm 0.0079 in.

- (1) Segment
- (2) Undercut
- (3) Mica
- (a) Correct
- (b) Incorrect

W1017092

Brush Wear

1. If the contact face of the brush is dirty or dusty, clean it with emery paper.
2. Measure the brush length (A) with vernier calipers.
3. If the length is less than the allowable limit, replace the yoke assembly and brush holder.

Brush length (A)	Factory spec.	14.0 mm 0.551 in.
	Allowable limit	9.0 mm 0.354 in.

W1017544

Brush Holder

1. Check the continuity across the brush holder and the holder support with an ohmmeter.
2. If it conducts, replace the brush holder.

W1017672

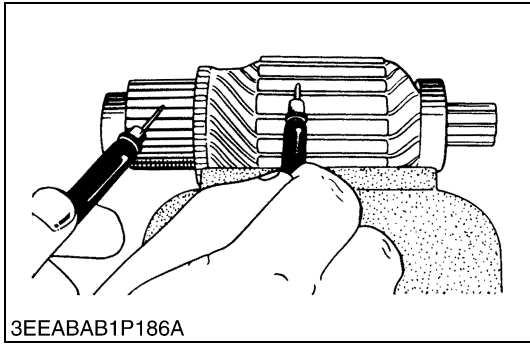

Armature Coil

1. Check the continuity across the commutator and armature coil core with an ohmmeter.
2. If it conducts, replace the armature.
3. Check the continuity across the segments of the commutator with an ohmmeter.
4. If it does not conduct, replace the armature.

W1017767

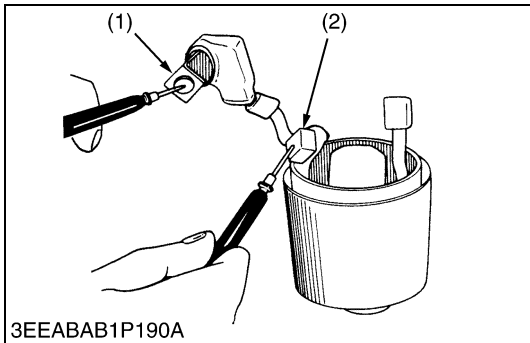
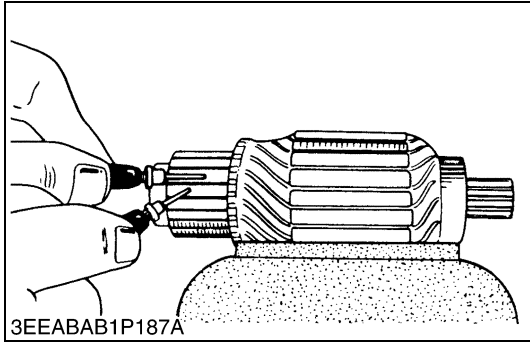

Field Coil

1. Check the continuity across the lead (1) and brush (2) with an ohmmeter.
2. If it does not conduct, replace the yoke assembly.
3. Check the continuity across the brush (2) and yoke (3) with an ohmmeter.
4. If it conducts, replace the yoke assembly.

- | | |
|-----------|----------|
| (1) Lead | (3) Yoke |
| (2) Brush | |

W1018015

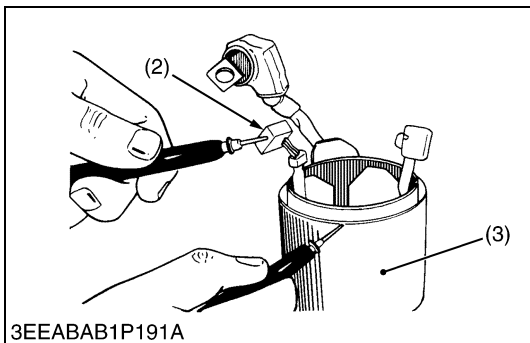

[3] CHARGING SYSTEM

(1) Checking

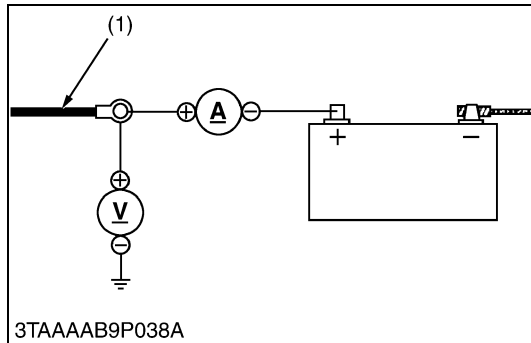

Battery Charging Current

- After starting the engine, disconnect the battery positive cord (+), and connect an ammeter and voltmeter. Then switch on all electrical loads (such as head lights) and measure the charging current.

■ **NOTE**

- Connect an ammeter only after starting the engine.
- When the electrical loads is considerably low or the battery is fully charged, the specified reading may not be obtained.

Factory spec.	Current	14 to 15 V
	Voltage	14 to 15 V
	Dynamo speed	5200 min ⁻¹ (rpm)

(1) Battery Positive Cord

W1018053

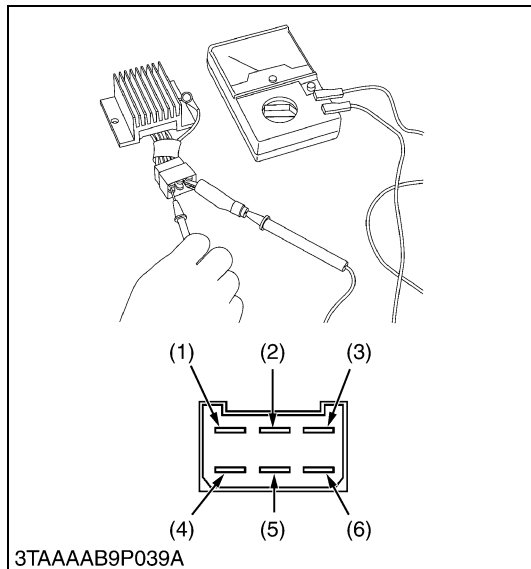

Continuity across Regulator's Terminals

- Remove the regulator coupler.
- Check with a tester whether the regulator is in optimum condition or not.

■ **Check Table**

■ **NOTE**

- Type to use a high-resistance tester as far as possible.
- The judgement should be as below table. "ON" if the indicator moves, otherwise "OFF".

Tester + terminal / Tester - terminal		Cord colors					
		Blue	Black	Blue	Green	Yellow	Red
Cord colors	Blue		OFF	ON	ON	ON	ON
	Black	ON		ON	ON	ON	ON
	Blue	ON	OFF		ON	ON	ON
	Green	OFF	OFF	OFF		OFF	OFF
	Yellow	OFF	OFF	OFF	OFF		OFF
	Red	ON	OFF	ON	ON	ON	

- (1) Blue
- (2) Black
- (3) Blue

- (4) Green
- (5) Yellow
- (6) Red

W1018232

(2) Disassembling and Assembling

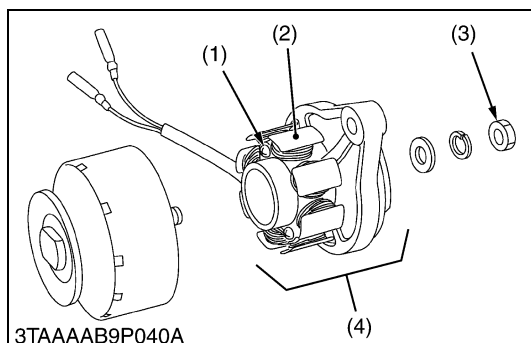

Stator

- Remove the nut (3) and separate the stator comp. (4).
- Unscrew the screws (1) and remove the stator (2).

(When reassembling)

Tightening torque	Nut	39.2 to 44.1 N·m 4.0 to 4.5 kgf·m 28.9 to 32.5 ft·lbs
-------------------	-----	---

- (1) Screw
- (2) Stator

- (3) Nut
- (4) Stator Comp.

W1018872

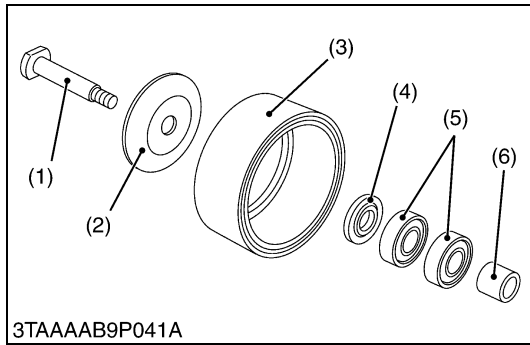

Rotor

1. Tap out the shaft (1) from the rotor (3).

(When reassembling)

- Take care the direction of the collar (4), the flat side should face to the pulley (2) side.

- | | |
|------------|--------------|
| (1) Shaft | (4) Collar |
| (2) Pulley | (5) Bearings |
| (3) Rotor | (6) Collar |

W1019015

(3) Servicing

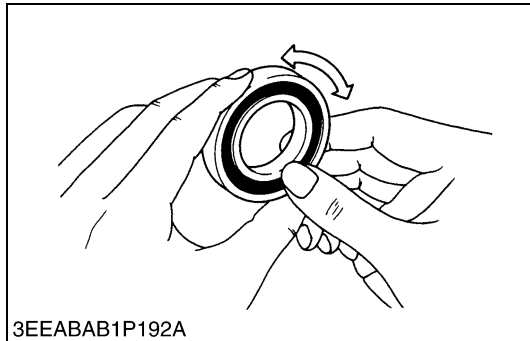

Bearing

1. Check the bearing for smooth rotation.
2. If it does not rotate smoothly, replace it.

W1019790

[4] LIGHTING SYSTEM

(1) Checking

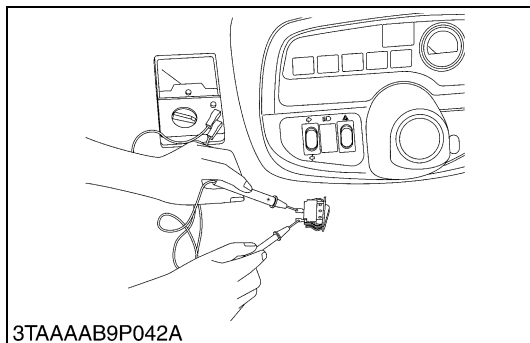

Head Light Switch Continuity

1. Remove the under panel.
2. Disconnect the wiring leads from head light switch and remove it.
3. Measure the resistance with an ohmmeter across the head light switch terminals in each position.
4. If the resistance differs from the factory specifications, the head light switch is faulty.

Resistance	Factory spec.	OFF	Infinity
		ON	0 Ω

W1019360

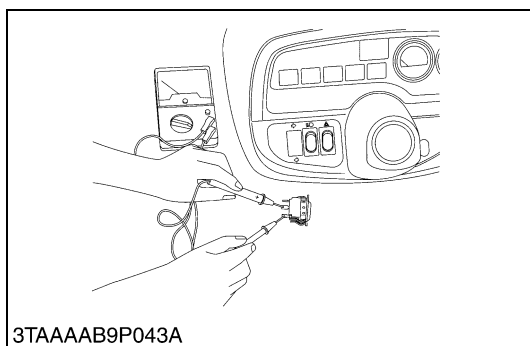

Blinker Switch Continuity

1. Remove the under panel.
2. Disconnect the connector from blinker switch and remove it.
3. Measure the resistance with an ohmmeter across the center terminal and terminal **R** or **L**.
4. If the resistance differs from the factory specifications, the blinker switch is faulty.

Resistance	Factory spec.	OFF	Infinity
		R	0 Ω
		L	0 Ω

W1019512

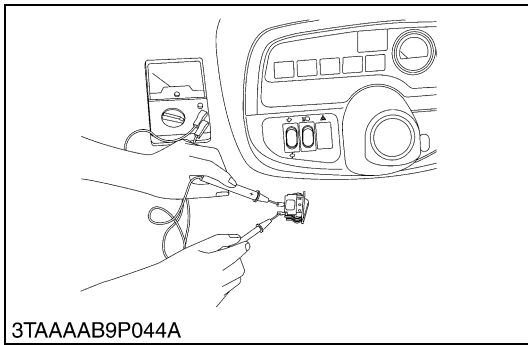

Hazard Light Switch Continuity

1. Remove the under panel.
2. Disconnect the wiring leads from hazard light switch and remove it.
3. Measure the resistance with an ohmmeter across the hazard light switch terminals in each position.
4. If the resistance differs from the factory specifications, the hazard light switch is faulty.

Resistance	Factory spec.	OFF	Infinity
		ON	0 Ω

W1019697

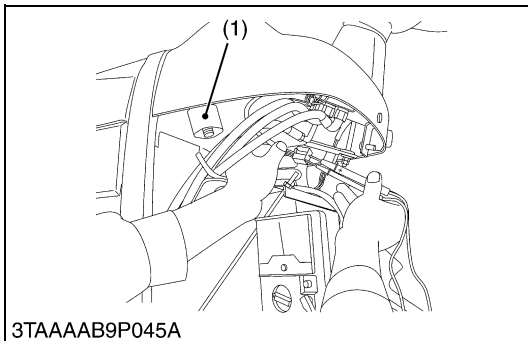

Flasher Unit

1. Remove the under panel.
2. Disconnect the coupler from flasher unit.
3. Measure the voltage with a voltmeter across the terminal **h** and terminal **c** or chassis.
4. If the voltage differs from the battery voltage, the wiring harness is faulty.

Voltage	Terminal h – Terminal c or Chassis	Approx. battery voltage
---------	--	-------------------------

(1) Flasher Unit

W1019868

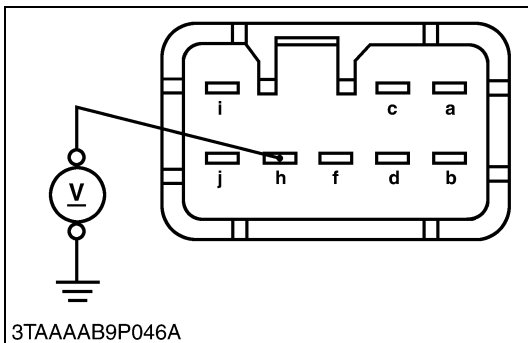

Flasher Unit Actuation Test

1. Set the hazard switch to the **ON** position, and make sure the hazard light gives 60 to 85 flashes for a minute.
2. With the main switch and the hazard switch at the **ACC** and **ON** positions, respectively, move the blinker switch to the left. Make sure that the right-hand light stays on and the left-hand light gives flashes earlier (by about 20 flashes) than when the hazard lamp is activated. Then move the blinker switch to the right and make sure the corresponding actions take place.
3. Now set the main switch to the **ACC** position and move the blinker switch alone. Make sure the same actions as above result.
4. If both the hazard switch and the blinker switch function but the above actions do not take place, replace the flasher unit with new one.

(1) Hazard Switch
(2) Blinker Switch

(3) Flasher Unit

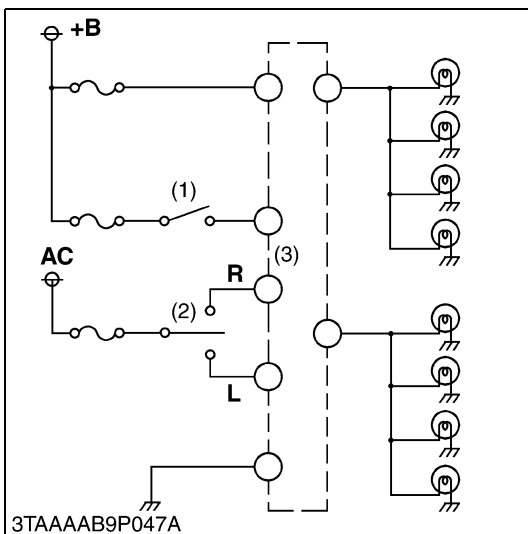

W1020049

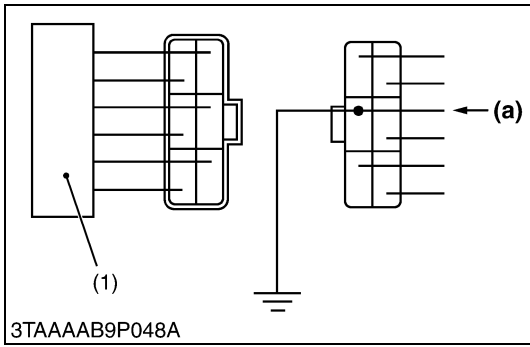

Charge Lamp (Charging Circuit)

1. Remove the under panel.
2. Disconnect the **6P** connector from the regulator after turning the main switch **OFF**.
3. Turn the main switch **ON** and connect a jumper lead from the wiring harness connector terminal (Black) to the chassis.
4. If the charge lamp does not light, the wiring harness or fuse is faulty.

(1) Regulator

(a) From Charge Lamp

W1020208

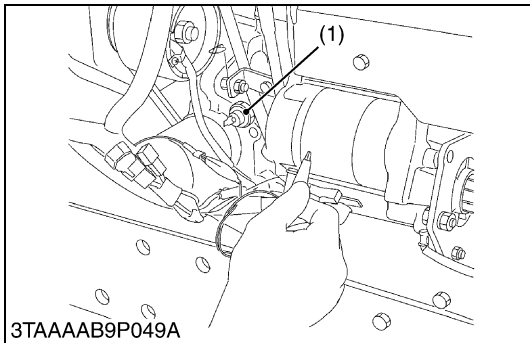

Engine Oil Pressure Lamp

1. Disconnect the lead from the engine oil pressure switch after turning the main switch **OFF**.
2. Turn the main switch **ON** and connect a jumper lead from the lead to the chassis.
3. If the engine oil pressure indicator lamp does not light, the wiring harness is faulty.

(1) Engine Oil Pressure Switch

(a) From Oil Pressure Lamp

W1025954

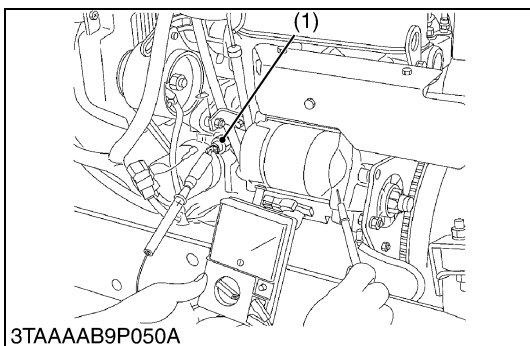
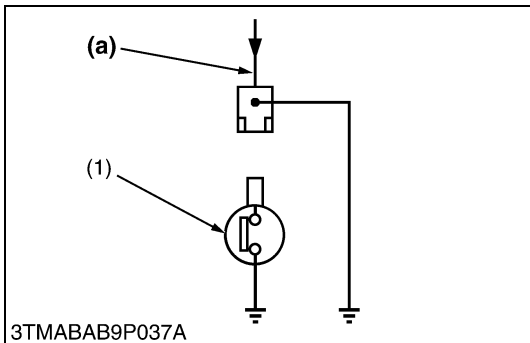

Engine Oil Pressure Switch Continuity

1. Measure the resistance with an ohmmeter across the switch terminal and the chassis.
2. If 0 ohm is not indicated in the normal state, the switch is faulty.
3. If infinity is not indicated at pressure over 4.9 kPa (0.5 kgf/cm², 7 psi), the switch is faulty.

Resistance (Switch terminal – Chassis)	In normal state	0 Ω
	At pressure over approx. 4.9 kPa (0.5 kgf/cm ² , 7 psi)	Infinity

(1) Engine Oil Pressure Switch

W1026084

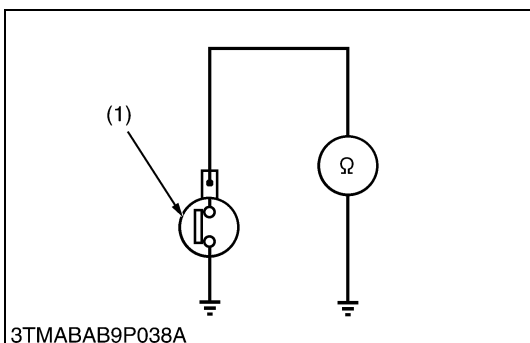

[5] GAUGES

(1) Checking

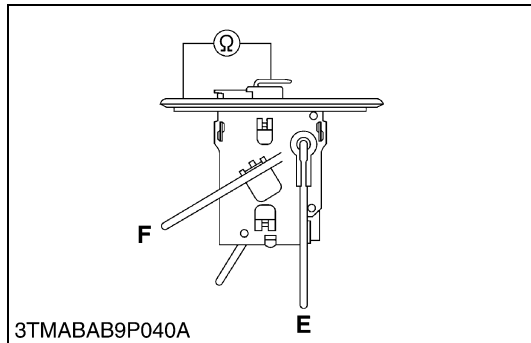

Fuel Level Sensor

1) Sensor Continuity

1. Remove the fuel level sensor from the fuel tank.
2. Measure the resistance with an ohmmeter across the sensor terminal and its body.
3. If the reference values are not indicated, the sensor is faulty.

Resistance (Sensor terminal – its body)	Reference value	Float at upper-most position	1 to 5 Ω
		Float at lower-most position	103 to 117 Ω

E : Empty

F : Full

W1024865

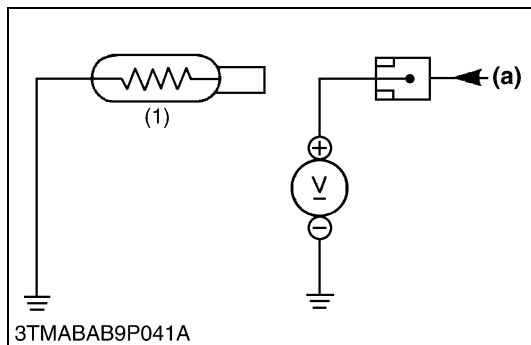

Coolant Temperature Sensor

1) Lead Terminal Voltage

1. Disconnect the lead from the coolant temperature sensor after turning the main switch **OFF**.
2. Turn the main switch **ON** and measure the voltage with a voltmeter across the lead terminal and the chassis.
If the voltage differs from the battery voltage, the wiring harness, fuse or coolant temperature gauge is faulty.

Voltage	Lead terminal – Chassis	Approx. battery voltage
---------	-------------------------	-------------------------

2) Sensor Continuity

1. Measure the resistances with an ohmmeter across the sensor terminal and the chassis.
2. If the reference value is not indicated, the sensor is faulty.

Resistance (Sensor terminal – Chassis)	Reference value	Approx. 16.1 Ω at 120 °C (248 °F)
		Approx. 27.4 Ω at 100 °C (212 °F)
		Approx. 51.9 Ω at 80 °C (176 °F)
		Approx. 153.9 Ω at 50 °C (122 °F)

(1) Coolant Temperature Sensor

(a) From Temperature Gauge

W1025104

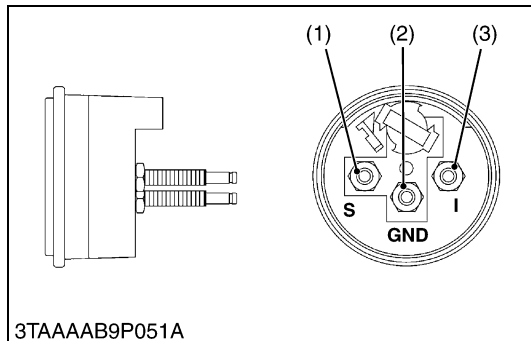
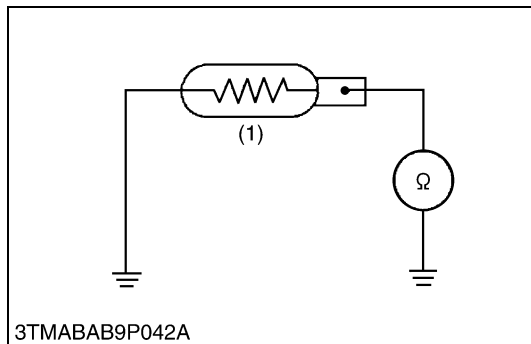

Fuel Gauge and Coolant Temperature Gauge Operation

1. Remove the under panel.
2. Turn the main switch to **ON** position. Measure the voltage with a voltmeter across the **I** terminal (3) and **GND** terminal (2) of the gauge.
3. If approx. battery voltage is indicated, the ignition and ground lead connections are good.
4. Turn the main switch to **OFF** position. Connect a jumper lead between **S** terminal (1) and **GND** terminal (2) of the gauge.
5. Turn the main switch to **ON** position. If the gauge resisters a full scale reading under those conditions, the gauge is good. If less than full scale reading is indicated, the gauge is defective and should be replaced.

(1) S Terminal

(3) I Terminal

(2) GND Terminal

W1027205

EDITOR:

KUBOTA FARM & INDUSTRIAL MACHINERY SERVICE, LTD.

64, ISHIZU-KITAMACHI, SAKAI-KU, SAKAI-CITY, OSAKA, 590-0823, JAPAN

PHONE : (81)72-241-1129

FAX : (81)72-245-2484

E-mail : ksos-pub@kubota.co.jp
