

# ASSEMBLY INSTRUCTIONS

MODEL BH77

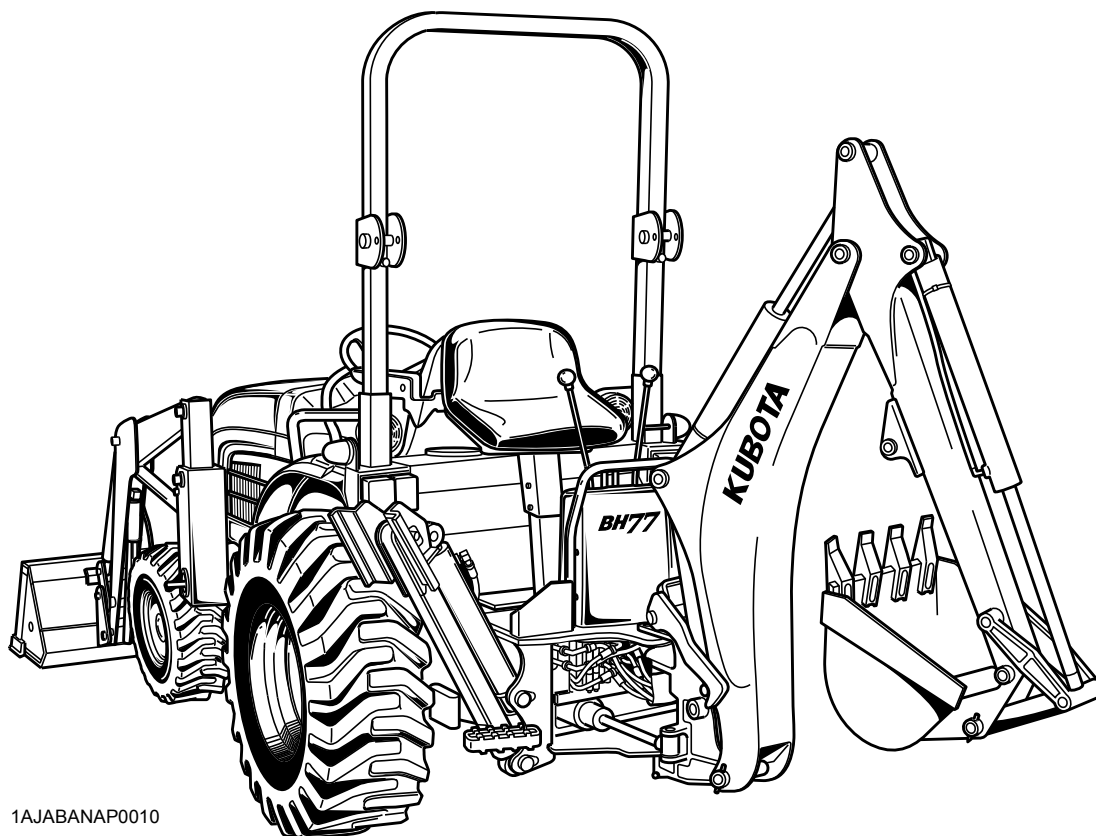

1AJABANAP0010

READ AND UNDERSTAND THIS MANUAL  
BEFORE ASSEMBLING

**Kubota**



# CONTENTS

TO THE DEALER.....	1
SAFETY .....	1
UNPACKING AND CHECKING PARTS .....	3
UNPACKING WOODEN CRATE.....	3
CHECKING PARTS.....	4
OPERATION .....	7
TRACTOR PREPARATION .....	8
ASSEMBLY [BH4972 BH4975 BH4976 BH4988].....	8
Layout of BH77 Backhoe Hydraulic Lines .....	8
Hydraulic Line .....	9
Sub Frame .....	14
CAB Spacer [BH4972].....	17
Rear Wheels .....	18
ASSEMBLY [BH4984].....	18
Layout of BH77 Backhoe Hydraulic Lines .....	18
Hydraulic Line .....	19
Sub Frame .....	19
Operator's Seat.....	20
Lever Stopper .....	24
Rear Wheels .....	25
ASSEMBLY [BH4962 BH4963 BH4973].....	25
Layout of BH77 Backhoe Hydraulic Lines .....	25
Hydraulic Line .....	25
Sub Frame .....	28
Hazard Light, Tool Box and SMV Emblem [BH4962, BH4963] .....	29
Operator's Seat [BH4962, BH4963].....	30
Label [BH4962, BH4963].....	37
CAB Spacer [BH4973].....	37
Rear Wheels .....	38
ASSEMBLY [BH4985].....	38
Sub Frame .....	38
Hydraulic Line .....	41
Tool Box.....	45
Installing the Lift Rod Bracket .....	45
ASSEMBLY [BH4996 BH4986].....	46
Layout of BH77 Backhoe Hydraulic Line .....	46
Hydraulic Line .....	47
Sub Frame .....	48
Rear Wheels .....	51
Installing the Stay for ROPS Connecting Bar [BH4996 only].....	52
Reinstalling the Top Link Holder [BH4996 only] .....	52
Installing the Lift Rod Bracket .....	52
SETTING UP THE BACKHOE.....	53
Dipperstick .....	53
Seat [Except BH4962 BH4963 BH4984] .....	54
Step Plate [BH4962 BH4963 BH4984] .....	54
Control Lever [BH4962 BH4963 BH4984] .....	54
Bucket.....	55

Mech. Thumb BH1976 (Option).....	56
INSTALLING THE BACKHOE .....	56
REMOVING THE BACKHOE.....	58
Removal of The Backhoe .....	58
Storage of The Backhoe.....	61
PRE-OPERATION CHECK.....	61
Lubrication .....	61
Transmission Fluid.....	62
ASSEMBLY TIME .....	64
TIGHTENING TORQUE OF BOLTS AND NUTS .....	65
General Torque Specification .....	65
TIGHTENING TORQUE OF ADAPTORS, ELBOWS AND OTHERS.....	66
CHECK LIST FOR INSPECTION AFTER ASSEMBLY .....	67

## TO THE DEALER

- This manual contains procedures intended to assist the dealer in unpacking and assembling the product before delivering to the customer.  
The customer's purchase is based on confidence in both the product and your store. Observe the procedures in this manual to assemble and adjust equipment for your customer's safety and satisfaction. When fully assembled, check function of each part and feature.
- The following safety alert symbol marks and indications are found throughout this manual in steps where particular attention is required so as to ensure your safety and to avoid product damage. Observe the instructions in these warnings where indicated.

 <b>DANGER</b>	Indicates an imminently hazardous situation which, if not avoided, will result in death or serious injury.
 <b>WARNING</b>	Indicates a potentially hazardous situation which, if not avoided, could result in death or serious injury.
 <b>CAUTION</b>	Indicates a potentially hazardous situation which, if not avoided, could result in minor or moderate injury.
<b>IMPORTANT :</b>	Indicates that equipment or property damage could result if instructions are not followed.
<b>NOTE :</b>	Gives helpful information

## SAFETY

To prevent accidents, read through the following items before starting work, and always regard safety when working. It is your responsibility to ensure your safety on the job.

### 1. Preparations

- Select a work site which is level, has sufficient space, and is not close to dangerous objects.
- Avoid poorly ventilated rooms. Asphyxiation from exhaust fumes is always a possibility that accompanies running engine.

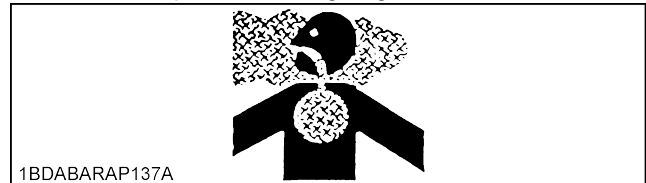

- Working clothes which may be pinched or caught in the equipment must not be worn. Loose clothing can cause serious injury or death.

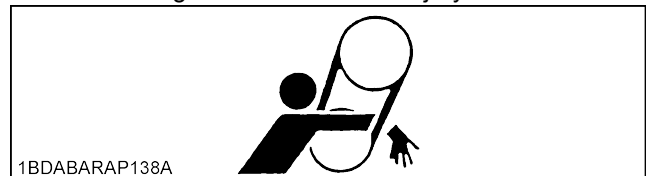

- Always wear a mask and protective goggles during work when dust or flying debris may be thrown by equipment.

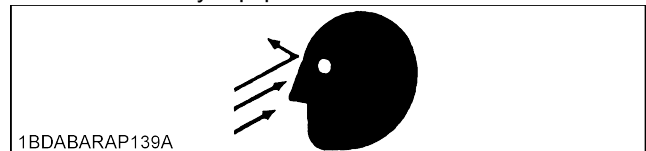

## 2. Assembly and adjustments

- (1) Before assembling equipment, read the assembly instructions for the product to become familiar with the equipment and procedures.

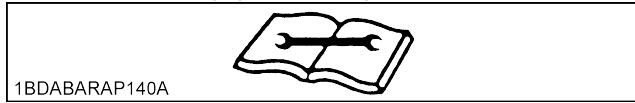

- (2) Use only adequate and required equipment, tools and instruments (e.g. torque wrench, battery hydrometer and etc.).
- (3) Set the parking brake and block wheels to prevent machine (or tractor) movement.
- (4) Lower the attachment or implement to the ground before assembling or adjusting equipment.
- (5) Before working under suspended or raised equipment, support the equipment or attachment to prevent the machine from falling or moving out of place.

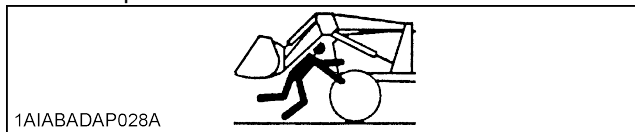

- (6) Keep fire from cigarettes, matches or other ignition sources away from fuel, oil, antifreeze and other flammable materials.



## 3. After assembly check

- (1) Before operating or test driving the equipment, read and understand the operator's manual.
- (2) Once the equipment is fully assembled, select a safe place for a test run. Prevent bystanders from approaching the equipment.

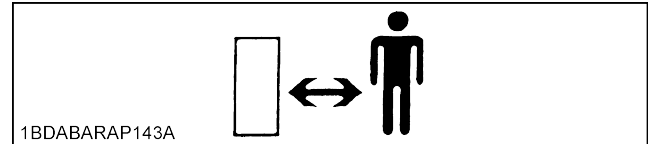

### DANGER

To avoid personal injury or death:

- Do not start engine or operate levers from anywhere other than the seat.

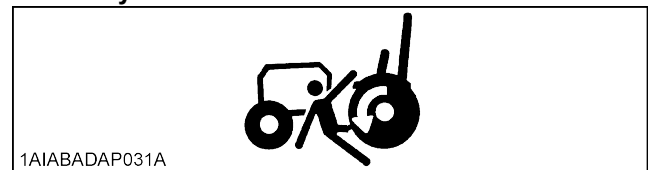

### DANGER

To avoid personal injury:

- Do not bypass-start the equipment. Short circuiting the starter terminal runs the risk that the equipment will start operating or moving unexpectedly.

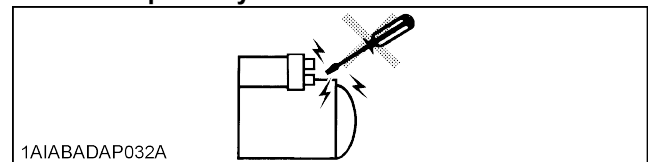

## ■ [S] processes

1. [S] processes mean any process that requires priority control due to its characteristics of having a high probability of leading to physical injuries or fire disasters because of abnormal values and defects in manufacturing quality.
2. The [S] marks in the text indicate the processes that include the following safety characteristics.
  - (1) Any assembly process with important safety characteristic values that require control to ensure product safety.
  - (2) Any assembly process with characteristic values having impact on the strength and performance of [S] parts.
  - (3) Previous occurrence of accidents related to [S] process (including probability.)

## UNPACKING AND CHECKING PARTS

### ■ UNPACKING WOODEN CRATE

1. Cutting metal bands (if two are banded together). Metal bands hold the two crates together as one. Cut these bands and separate the crates.
2. Unpacking the crates
  - (1) Hook a hoist to the 4 corners of the crate and raise the hoist cable until taut. This serves to prevent the upper part of the crate from striking the backhoe when cut.
  - (2) Saw the crate as indicated in the figure below.

#### IMPORTANT :

- Sawing outside the indicated area may damage the backhoe or accessory parts.
- Be sure that the crate is free of other obstructions (e.g. nails, staples and etc.).

- (3) Raise the upper part of crate and remove from the immediate area.
- (4) Remove the remaining slats from the crate.

These are indicated by the oblique lines in

**Figure 1**..... // // // //

**Figure 1** : Cutting area of the crate

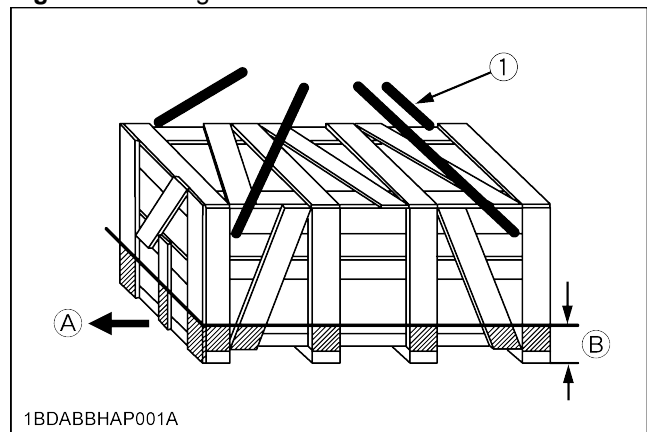

(1) Nylon strap

(A) Front

(B) 300 mm (12 in.)

### ■ CHECKING PARTS

Remove all backhoe components. Referring to the illustration, ensure that all components have been included.

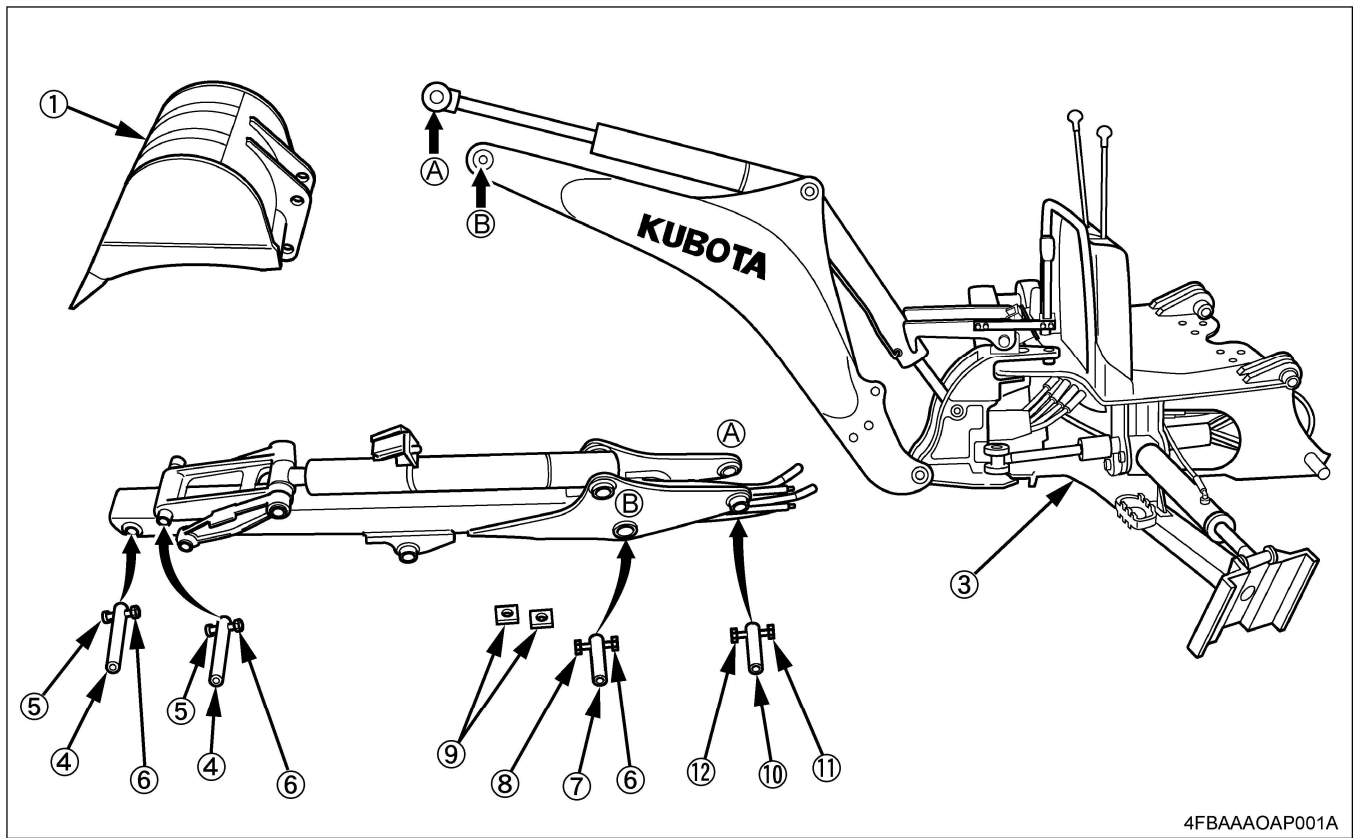

- (1) Backhoe bucket
- (2) Dipperstick (arm) assy
- (3) Main frame-Boom assy
- (4) Pin (24.9 x 157)
- (5) Hex. bolt (M10 x 55)
- (6) Locking nut (M10)

- (7) Pin (29.9 x 202)
- (8) Hex. bolt (M10 x 65)
- (9) Spacer
- (10) Pin (24.9 x 137)
- (11) Hex. bolt (M6 x 50)
- (12) Locking nut (M6)

◆ **Seat assy**  
**[BH4972, BH4975B, BH4976A, BH4996A, BH4988]**

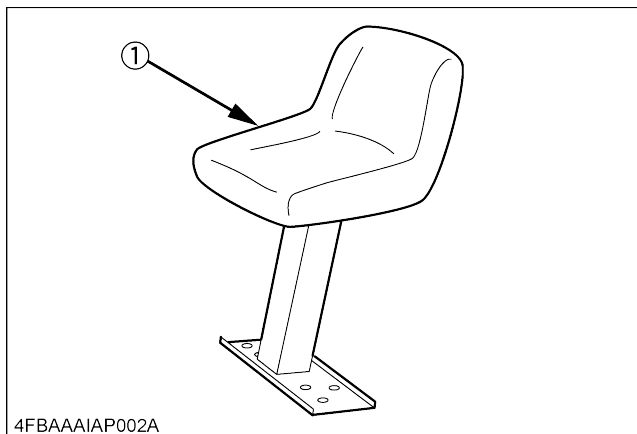

(1) Seat assy

◆ **Seat support**  
**[BH4962, BH4963, BH4984]**

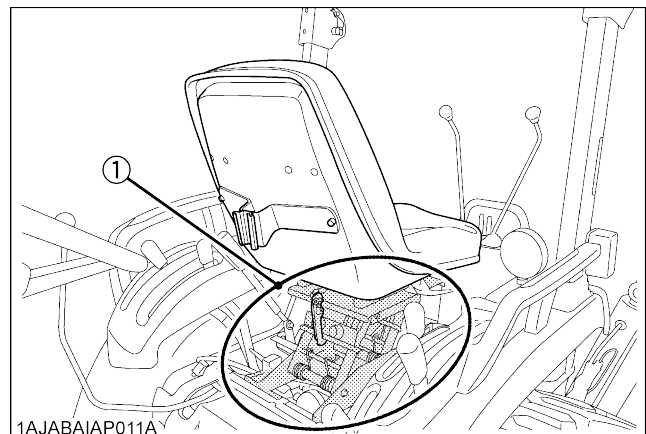

(1) Seat support

**[BH4984]**

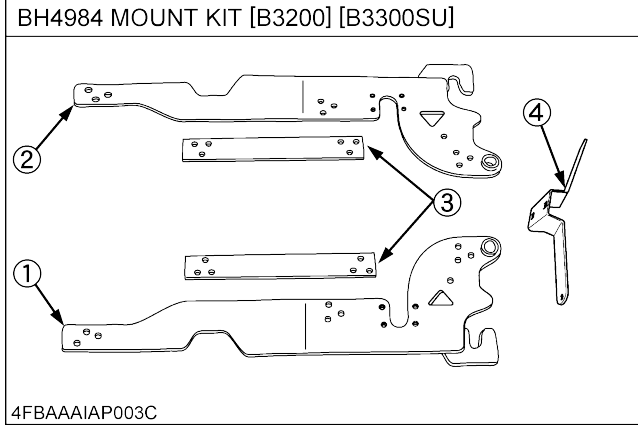

- (1) Sub frame LH
- (2) Sub frame RH
- (3) Connecting plate
- (4) SMV stay "See page 21."

**[BH4975B]**

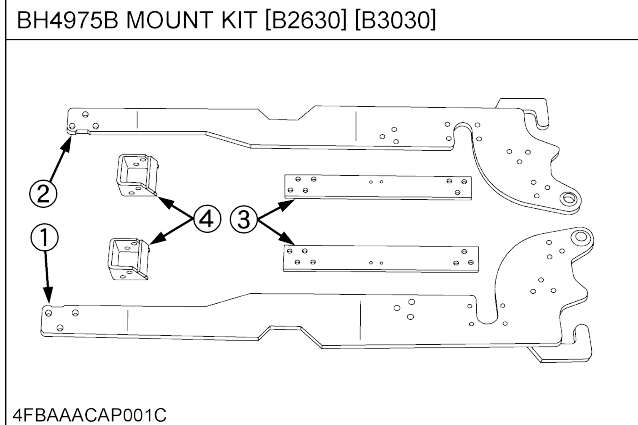

- (1) Sub frame LH
- (2) Sub frame RH
- (3) Connecting plate
- (4) Frame bracket

**[BH4976A]**

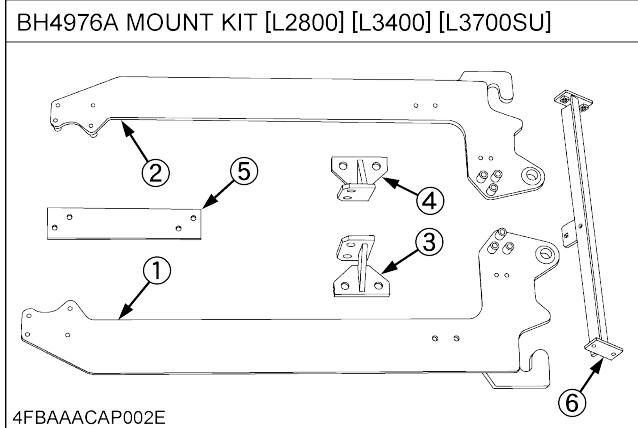

- (1) Sub frame LH
- (2) Sub frame RH
- (3) Frame bracket LH
- (4) Frame bracket RH
- (5) Support joint
- (6) Fender bracket "See page 12."

**[BH4988]**

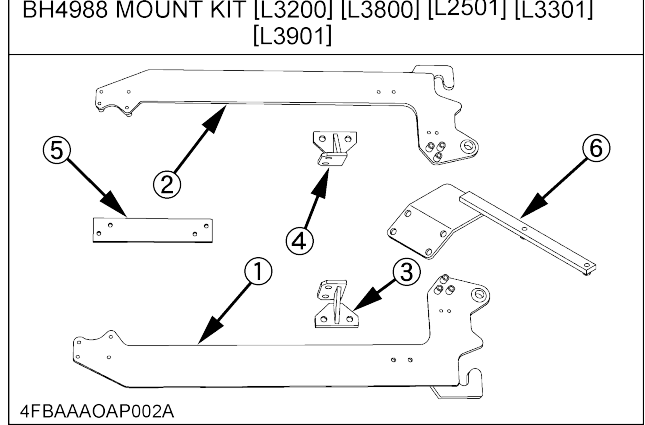

- (1) Sub frame LH
- (2) Sub frame RH
- (3) Frame bracket LH
- (4) Frame bracket RH
- (5) Support joint
- (6) Toolbox stay

**[BH4996A]**

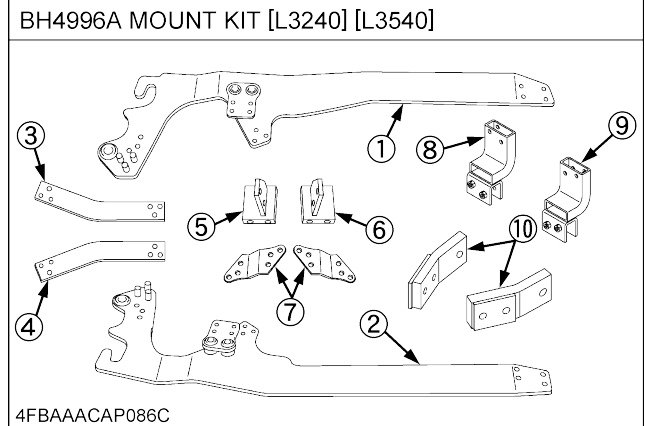

- (1) Sub frame LH
- (2) Sub frame RH
- (3) Connecting plate RH
- (4) Connecting plate LH
- (5) Rear bracket LH
- (6) Rear bracket RH
- (7) Frame support
- (8) Stay for ROPS connecting bar RH
- (9) Stay for ROPS connecting bar LH
- (10) Lift rod bracket

**[BH4986]**

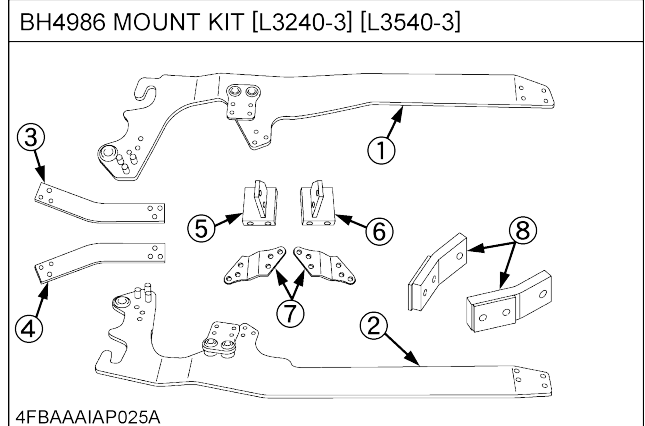

- (1) Sub frame LH
- (2) Sub frame RH
- (3) Connecting plate RH
- (4) Connecting plate LH
- (5) Rear bracket LH
- (6) Rear bracket RH
- (7) Frame support
- (8) Lift rod bracket



**[BH4972]**

BH4972 MOUNT KIT [B3000CAB]

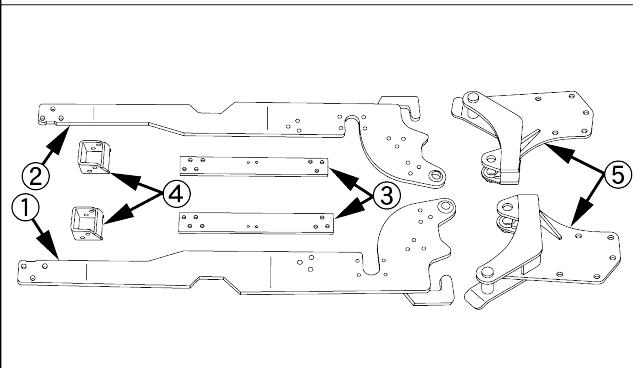

4FBAAAOP013A

- (1) Sub frame LH
- (2) Sub frame RH
- (3) Connecting plate
- (4) Frame bracket
- (5) Cab spacer

**[BH4973]**

BH4973 MOUNT KIT [B2650CAB] [B3350CAB]

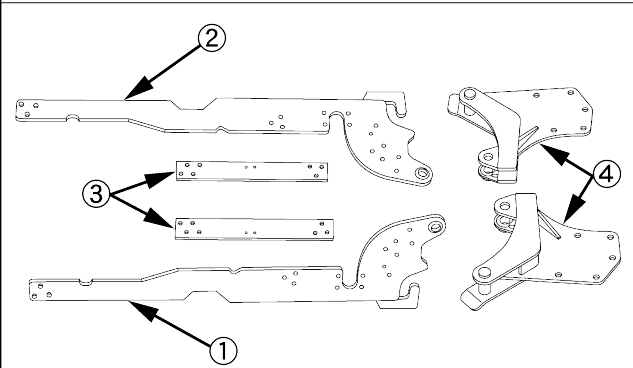

4FBAAAOP029A

- (1) Sub frame LH
- (2) Sub frame RH
- (3) Connecting plate
- (4) Cab spacer

**[BH4962, BH4963]**

BH4962 MOUNT KIT [B2650ROPS] [B3350ROPS]  
BH4963 MOUNT KIT [B3350SU]

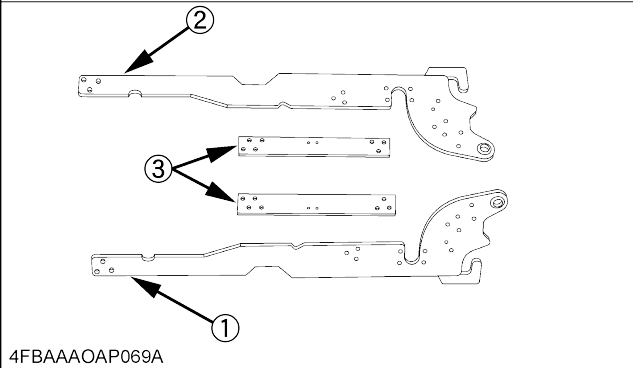

4FBAAAOP069A

- (1) Sub frame LH
- (2) Sub frame RH
- (3) Connecting plate

**[BH4985]**

BH4985 MOUNT KIT [L3560]

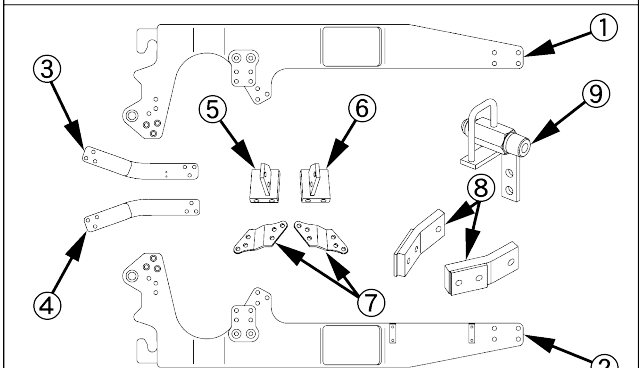

4FBAAAOP050A

- (1) Sub frame LH
- (2) Sub frame RH
- (3) Connecting plate RH
- (4) Connecting plate LH
- (5) Rear bracket LH
- (6) Rear bracket RH
- (7) Frame support
- (8) Lift rod bracket
- (9) Joint

◆ **Lever stopper**

**[BH4984]**

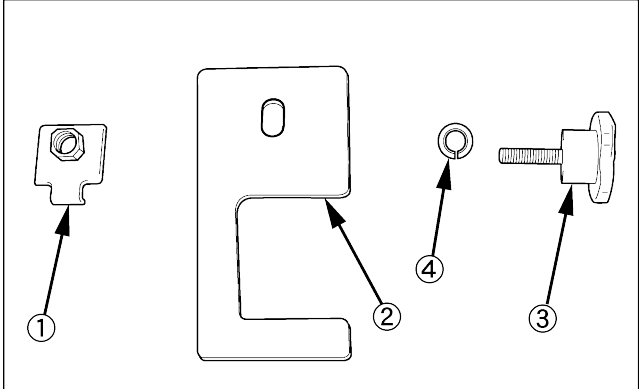

4FBAAAFAP035A

- (1) Stopper
- (2) Lever stopper
- (3) Knob bolt
- (4) Spring washer

## OPERATION

1. The BH77 backhoe is approved for use on:
  - B3200 and B3300SU tractor(s) with foldable ROPS, LA504 Loader and BH4984 mount kit.
  - B2650 and B3350 tractors with CAB, LA534 Loader and BH4973 mount kit.
  - B2650 and B3350 tractors with foldable ROPS, LA534 Loader and BH4962 mount kit.
  - B3350SU tractor with foldable ROPS, LA534 Loader and BH4963 mount kit.
  - B2630 and B3030 tractors with foldable ROPS, LA403 Loader and BH4975B mount kit.
  - B3000 tractor with CAB, LA403 Loader and BH4972 mount kit.
  - L2800, L3400 and L3700SU tractors with rigid and foldable ROPS, LA463 Loader and BH4976A mount kit.
  - L3200, L3800, L2501, L3301 and L3901 tractors with foldable ROPS, LA524 or LA525 Loader and BH4988 mount kit.
  - L3240 and L3540 tractors with rigid and foldable ROPS, LA514 or LA724 Loader and BH4996A mount kit.
  - L3240-3 and L3540-3 tractors with foldable ROPS, LA514 or LA724 Loader and BH4986 mount kit.
  - L3560 tractor with foldable ROPS, LA555 or LA805 Loader and BH4985 mount kit.
2. When using other implements with the backhoe removed, mount the 3-point linkage to the tractor.
3. Removal and reinstallation of the backhoe sub frame should be performed by your KUBOTA dealer.
4. Save the 3-point linkage components when they are removed.

### ◆ Operating seat

1.  Attach the operating seat to the seat link. Tighten the bolts by the correct tightening torque.

### IMPORTANT :

- When backhoe is attached to B2650, B3350 and B3000, use the anterior holes of seat link by necessity.

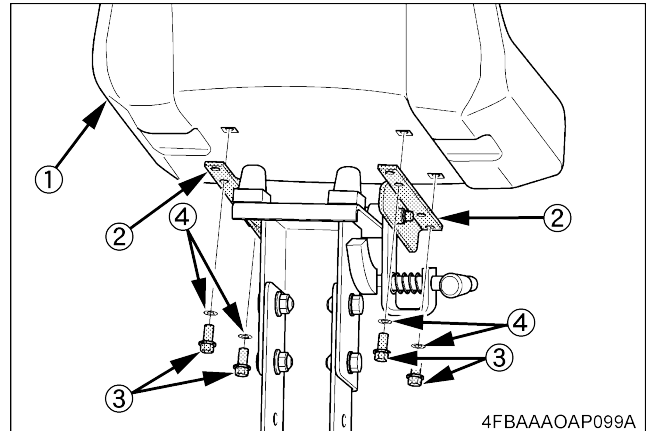

(1) Seat

(2) Seat link

(3) 4 - 5/16 UNC x 80 bolts (75599-01220)

(4) 4 - spring washers (04512-50080)

Tightening torque: 7.5 to 10.7 N-m

(0.8 to 1.1 kgf-m, 5.5 to 7.9 ft-lbs)

◆ **Operating seat support link**

1. Before starting the tractor, unlock the backhoe's seat by lifting the support link lever and tilting the seat forward. Make sure the lever is locked.
2. To use the backhoe, first tilt the tractor's seat forward. Next, unlock the backhoe's seat by lifting the support link lever and tilting the seat backward and down. Make sure the lever is locked.
3. To avoid pinching your hand or fingers, keep them away from the seat support link.

**[BH4972, BH4973, BH4975, BH4996, BH4986, BH4988, BH4985]**

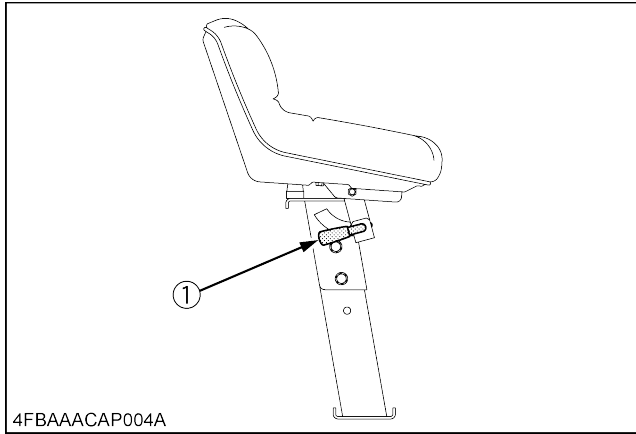

(1) Support link lever

**[BH4976]**

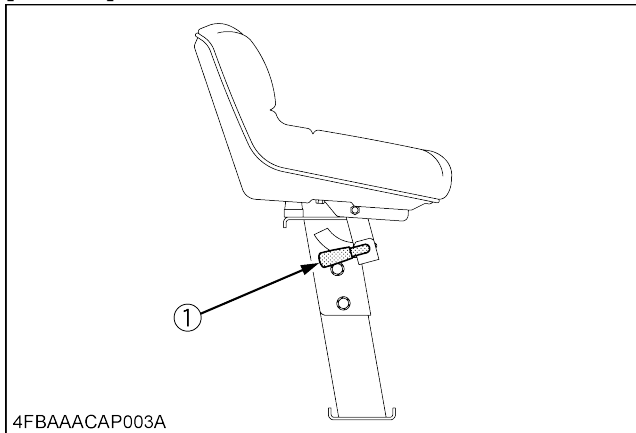

(1) Support link lever

**TRACTOR PREPARATION**

1. Park the tractor on a hard and level surface.
2. Remove the 3-point linkage from the tractor.
3. Remove the rear wheels.

**NOTE :**

- Do not remove PIN (LOWER LINK) when installing backhoe sub frames (BH4962, BH4963, BH4973 only).

**ASSEMBLY [BH4972 BH4975 BH4976 BH4988]**

**Layout of BH77 Backhoe Hydraulic Lines [BH4972]**

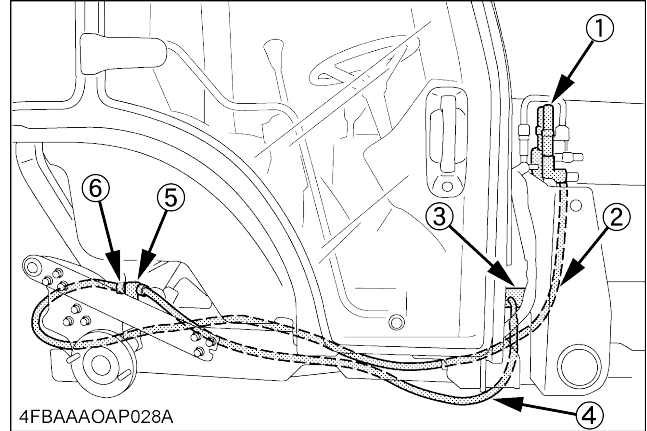

**[BH4975, BH4976, BH4988]**

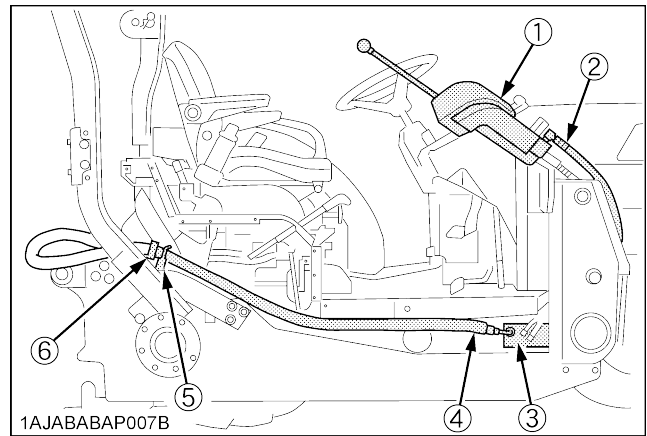

- |                        |                         |
|------------------------|-------------------------|
| (1) Front loader valve | (4) Backhoe outlet hose |
| (2) Backhoe inlet hose | (5) Coupler joint       |
| (3) Hydraulic block    | (6) Female coupler      |

## Hydraulic Line

[BH4972]

1. To replace the front loader power beyond hose (1), disconnect the front loader inlet hose (2) from the hydraulic block. Disconnect the front loader power beyond hose.

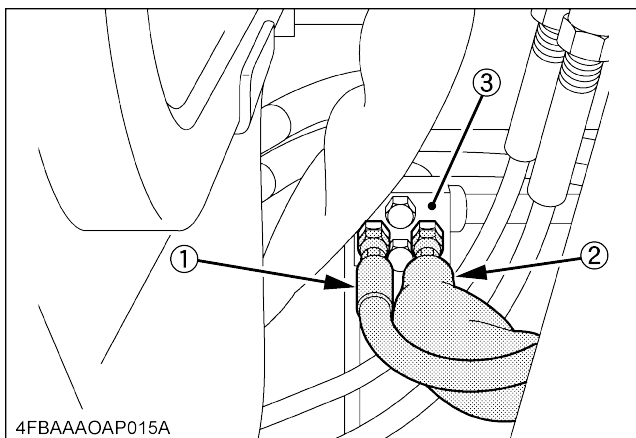
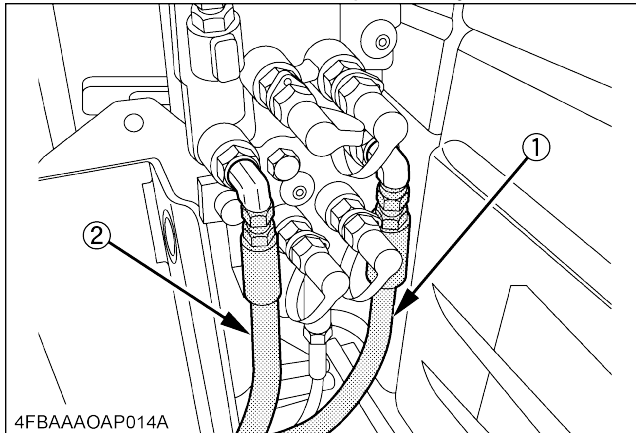

- (1) Front loader power beyond hose
- (2) Front loader inlet hose
- (3) Hydraulic block

2. Connect the backhoe inlet hose to the power beyond port (c) adapter. Route the backhoe inlet hose as shown below.

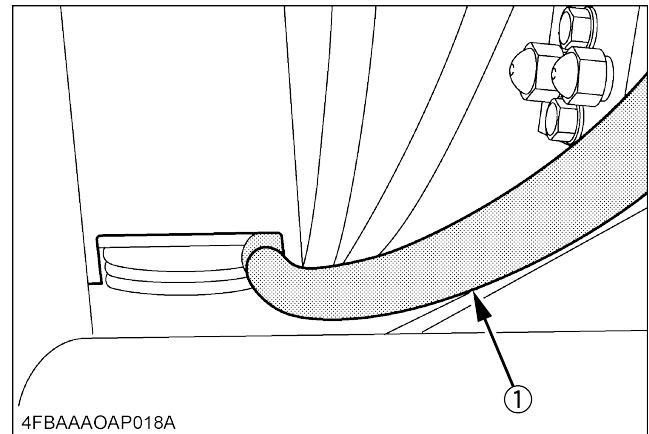
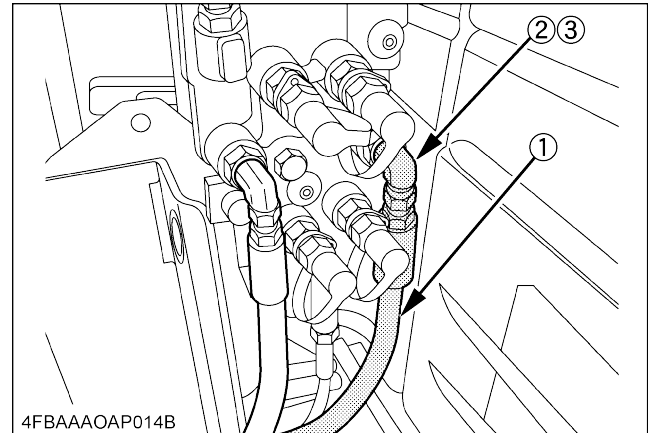

- (1) Backhoe inlet hose
- (2) Power beyond port (C)
- (3) Adapter

3. Connect the backhoe outlet hose to the power beyond port (c) of the hydraulic block at the specified angle.

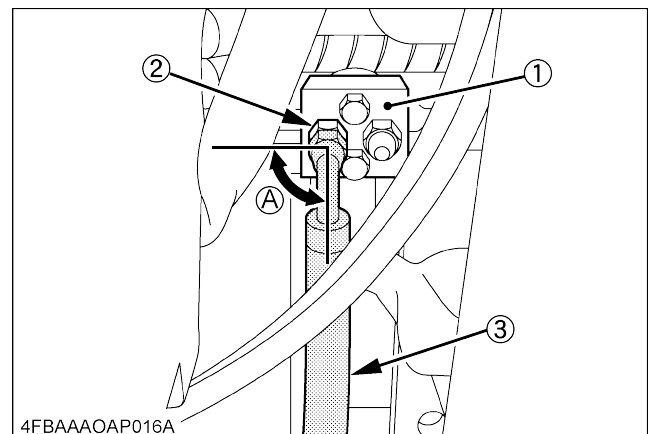

- (1) Hydraulic block
  - (2) Power beyond port (C)
  - (3) Backhoe outlet hose
- (A) 90°

Connect the front loader inlet hose.

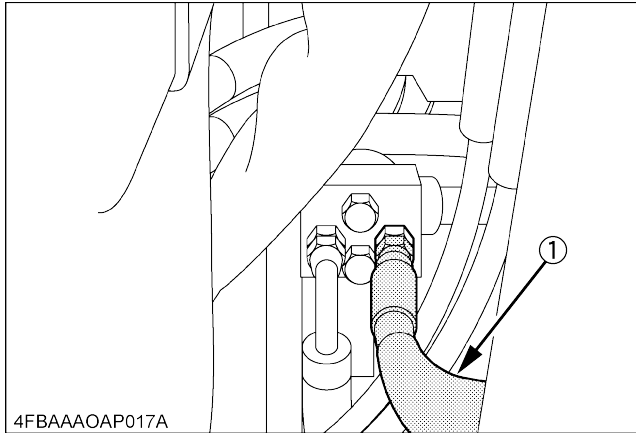

(1) Front loader inlet hose

**[BH4975, BH4976, BH4988]**

1. Disconnect the front loader power beyond hose.

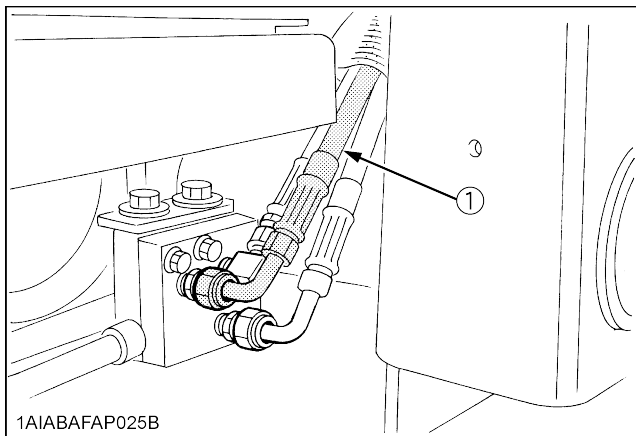
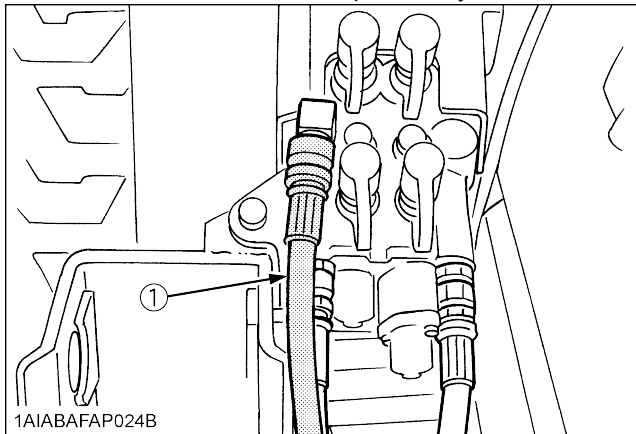

(1) Front loader power beyond hose

2. Loosen the power beyond port adapter lock nut and turn the adapter away from the tractor 5 degrees. Connect the backhoe inlet hose to the power beyond port (c) adapter. Route the backhoe inlet hose above the hydraulic block.

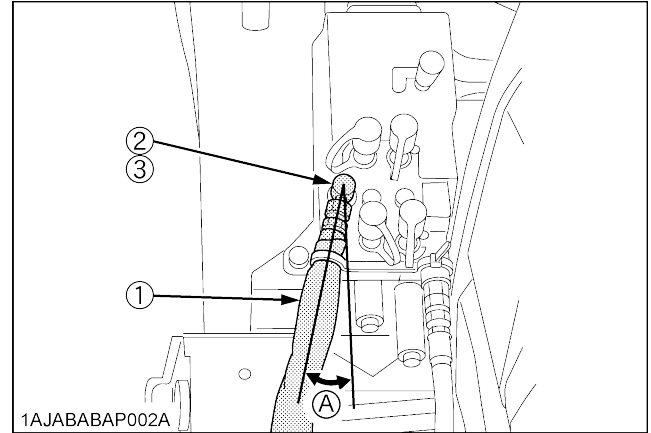

(1) Backhoe inlet hose (A) 5°  
 (2) Power beyond port (C)  
 (3) Adapter

**IMPORTANT :**

- Make sure that the loader hydraulic hose quick coupler, with the red dust plug, can be easily connected without contacting the backhoe inlet hose.

3. Connect the backhoe outlet hose to the power beyond port (c) of the hydraulic block at the specified angle.

**[BH4975]**

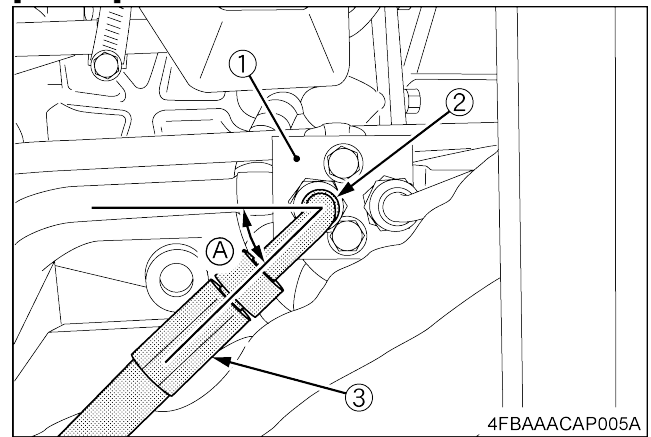

(1) Hydraulic block (A) 45°  
 (2) Power beyond port (C)  
 (3) Backhoe outlet hose

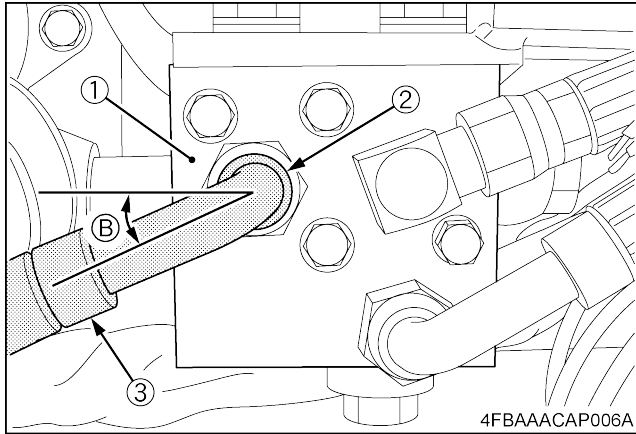
**[BH4976, BH4988]**

- (1) Hydraulic block  
 (2) Power beyond port (C)  
 (3) Backhoe outlet hose

(B) 15°

**[BH4972, BH4975, BH4976, BH4988]**

4. Attach the frame bracket to the rear tractor frame.
5. Pass the inlet and outlet hoses through the sleeves and secure them by the cord bands on both sides.
6. Connect the female coupler with the blue cap to the coupler joint, using thread tape.
7. Tighten the coupler joint to the specified torque.
8. Connect the backhoe inlet hose to the coupler joint at the specified angle.
9. Pass the backhoe outlet hose through the guide of coupler joint guide.
10. Wrap the sealing tape around the threads of the outlet hose and connect the male coupler with the red cap to the outlet hose.
11. Attach the coupler joint to the connecting plate.

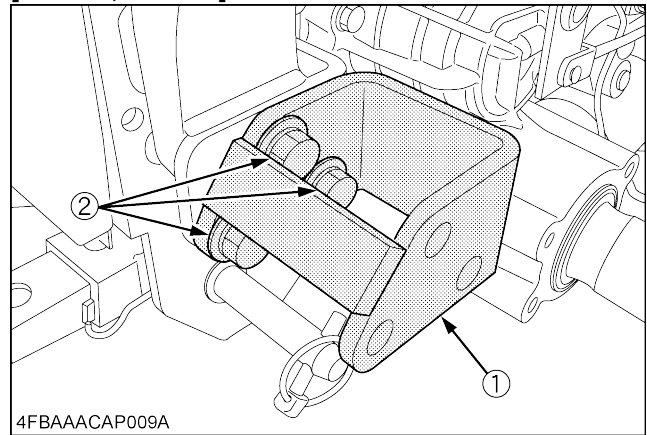
**[BH4972, BH4975]**

- (1) Bracket  
 (2) 3 - M16 x 50 bolts  
     3 - 5/8 hardened plain washers  
     3 - M16 spring lock washers

Tightening torque: 196 to 225 N-m  
 (20.0 to 23.0 kgf-m, 145 to 166 ft-lbs)

**NOTE :**

- Tighten the fasteners to the specified torque.

[BH4972, BH4975]

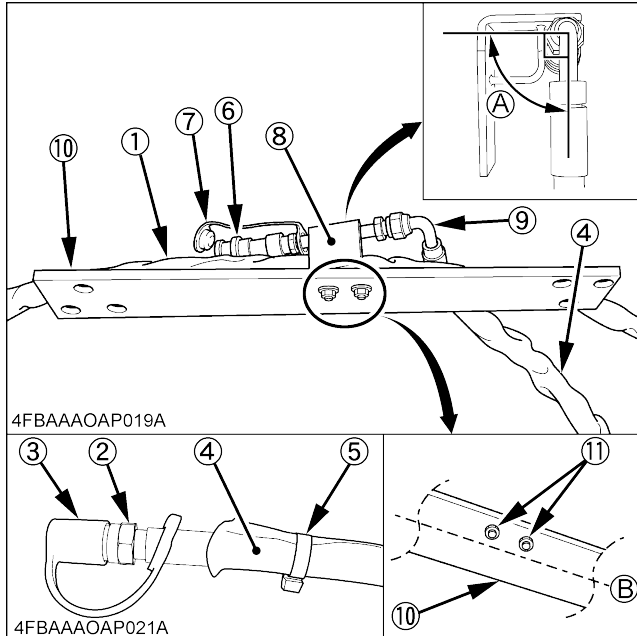

4FBAAAOP019A

4FBAAAOP021A

- (1) Outlet hose
- (2) Male coupler
- (3) Cap (red)
- (4) Sleeve
- (5) Cord band
- (6) Female coupler
- (7) Cap (blue)
- (8) Coupler joint
- (9) Inlet hose
- (10) Connecting plate
- (11) 2 - M8 x 20 flange bolts  
2 - M8 nuts

Tightening torque: 23.6 to 27.4 N-m  
(2.4 to 2.8 kgf-m, 17.4 to 20.2 ft-lbs)

(A) 90°  
(B) Center line

[BH4976, BH4988]

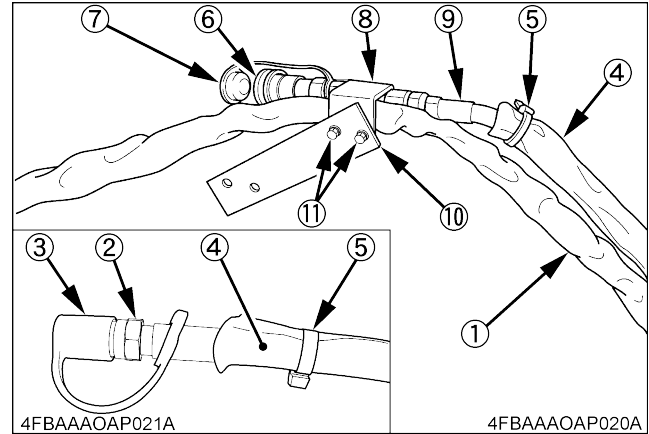

4FBAAAOP021A

4FBAAAOP020A

- (1) Outlet hose
- (2) Male coupler
- (3) Cap (red)
- (4) Sleeve
- (5) Cord band
- (6) Female coupler
- (7) Cap (blue)
- (8) Coupler joint
- (9) Inlet hose
- (10) Support joint
- (11) 2 - M8 x 20 flange bolts  
2 - M8 nuts

Tightening torque: 23.6 to 27.4 N-m  
(2.4 to 2.8 kgf-m, 17.4 to 20.2 ft-lbs)

12. Detach the fender bracket from the tractor fender.  
(BH4976 only)

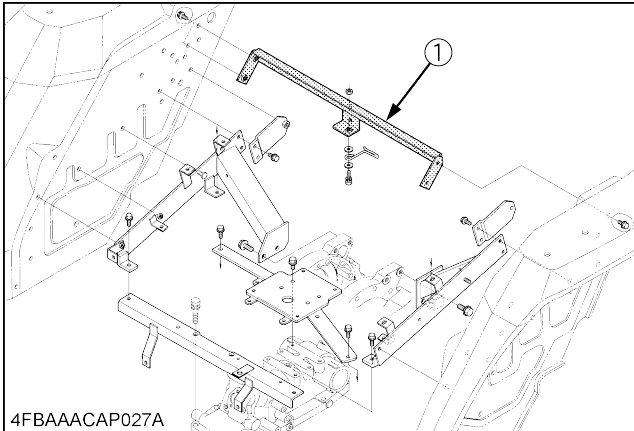

(1) Fender bracket

Afterwards, attach the fender bracket to the tractor fender. (BH4976 only)

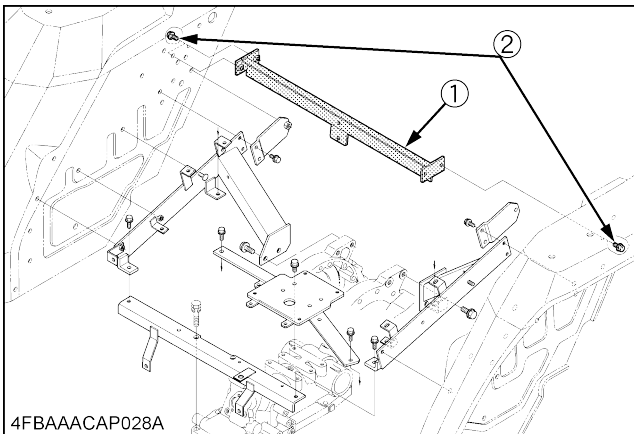

(1) Fender bracket  
(2) 2 - M8 x 16 flange bolts

Tightening torque: 23.6 to 27.4 N-m  
(2.4 to 2.8 kgf-m, 17.4 to 20.2 ft-lbs)

13. Detach the fender bracket from the tractor fender.  
(BH4988 only)

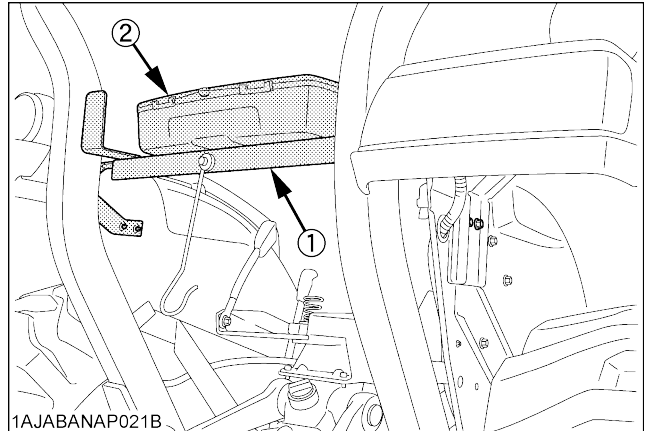

(1) Fender bracket  
(2) Tool box

Detach the tool box from the fender bracket.  
Afterwards, attach the tool box and the stay to the left side of the tractor ROPS.

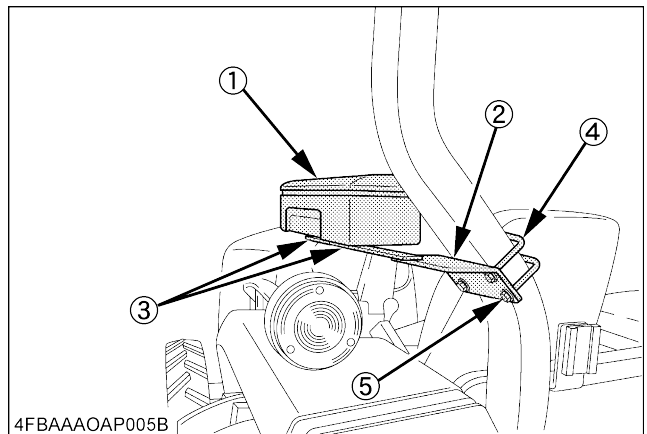

(1) Tool box  
(2) Tool box stay  
(3) 2 - M8 x 25 w-sems bolts  
(4) U-bolt  
(5) 4 - M10 flange nuts

**NOTE :**

- Secure the tool box horizontally as shown above.



14. Install the 5/8 - 18 x 4 stop bolt into the rear hole of the foldable ROPS hinge section. One side only. (BH4975)

Tighten the stop bolt slightly and secure it with the 5/8 - 18 nut.

**NOTE :**

- Be careful not to over-tighten the bolt into the welded nut.



**CAUTION**

To avoid personal injury:

- See Operator's Manual, Operations Section "Operating foldable ROPS!", for the correct free fall adjustment to the upper frame of the ROPS.

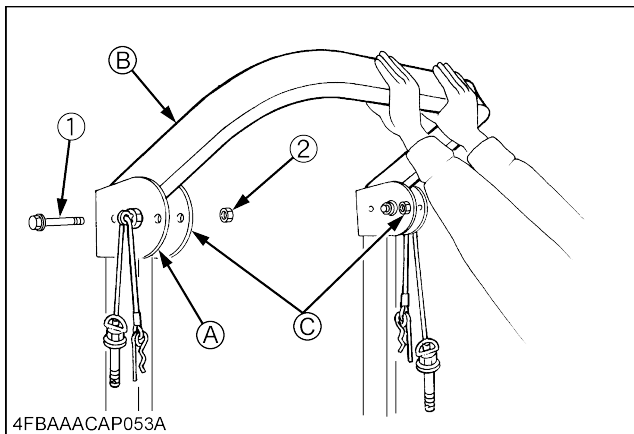

- (1) 5/8 - 18 x 4 stop bolt  
 (2) 5/8 - 18 nut  
 (A) Rear hole of the foldable ROPS hinge section  
 (B) Upper frame  
 (C) 5/8 - 18 welded nut



**CAUTION**

To avoid personal injury:

- Do not operate the backhoe with ROPS in held position.
- "Fold the ROPS down only when absolutely necessary and fold it up and lock it again as soon as possible!"
- Hold the ROPS tightly with both hands and fold the ROPS slowly and carefully.

Make sure that both set bolts are properly installed as soon as the ROPS is in the upright position and secured with hair pins.

**Sub Frame**

1. Lift the sub frame into place using a hoist in the rear and a jack in the front. Attach the sub frame with the supplied nuts and bolts, but do not torque them.

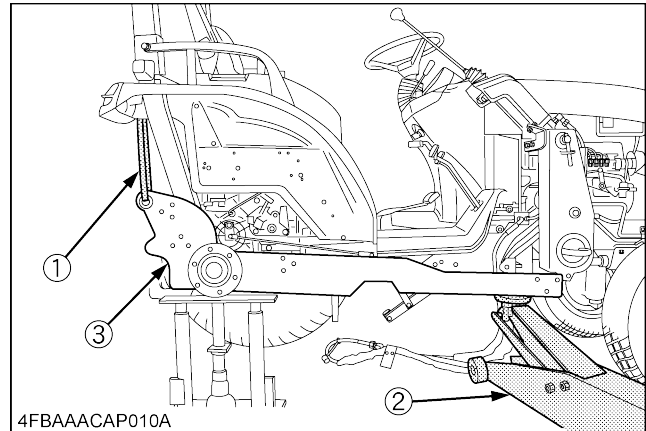

- (1) Nylon strap  
 (2) Jack  
 (3) Sub frame

**[BH4972]**

Place the sub frame between the inlet and outlet hoses as shown below.

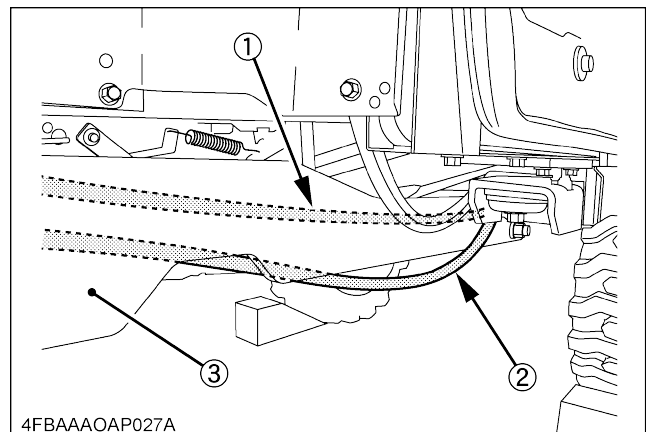

- (1) Inlet hose  
 (2) Outlet hose  
 (3) Sub frame

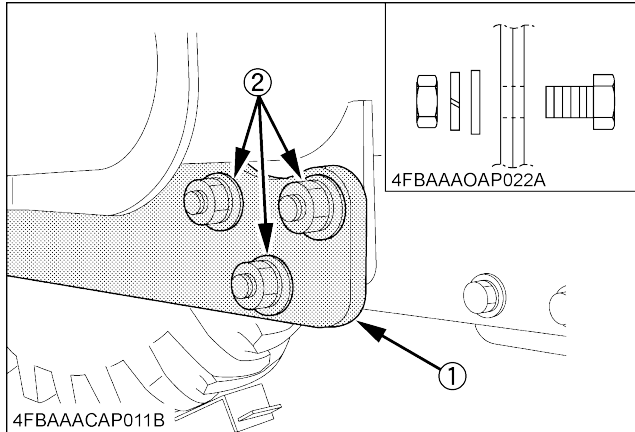
**[BH4972, BH4975]**

(1) Sub frame

(2) 3 - M16 x 50 bolts

3 - 5/8 hardened plain washers

3 - M16 spring lock washers

3 - M16 nuts

Tightening torque: 196 to 225 N-m

(20.0 to 23.0 kgf-m, 145 to 166 ft-lbs)

**IMPORTANT :**

- Do not tighten fasteners until all components are assembled.
- Finally tighten the fasteners to the specified torque.

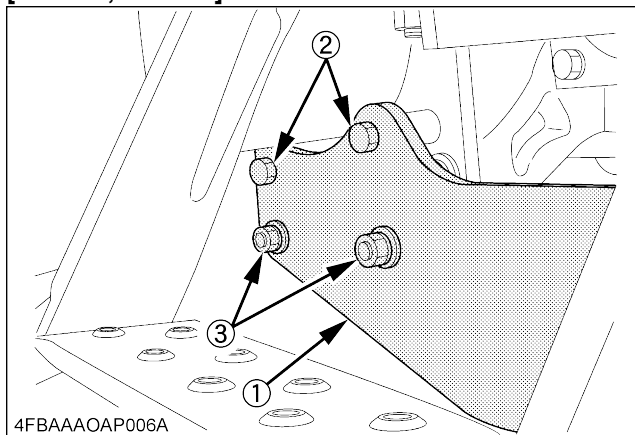
**[BH4976, BH4988]**

(1) Sub frame

(2) 2 - M12 x 75 bolts

(3) 2 - M12 x 90 bolts

2 - 1/2 hardened plain washers

2 - M12 spring lock washers

2 - M12 nuts

Tightening torque: 77.5 to 90.1 N-m

(7.9 to 9.2 kgf-m, 57.2 to 66.5 ft-lbs)

**IMPORTANT :**

- Be sure to apply a nylon strap to the back end of the sub frame for hoisting it.
- For the three-section auxiliary control valve, move the inlet hose behind the sub frame (below the auxiliary control valve) before hoisting the sub frame.

- Do not tighten fasteners until all components are assembled.
- Finally tighten the fasteners to the specified torque.

2. Using the supplied bolts and nuts, loosely fix the following components to the sub frame:

BH4972, BH4975: bracket, rear axle case and connecting plate.

BH4976, BH4988: ROPS frame, bracket and rear axle case.

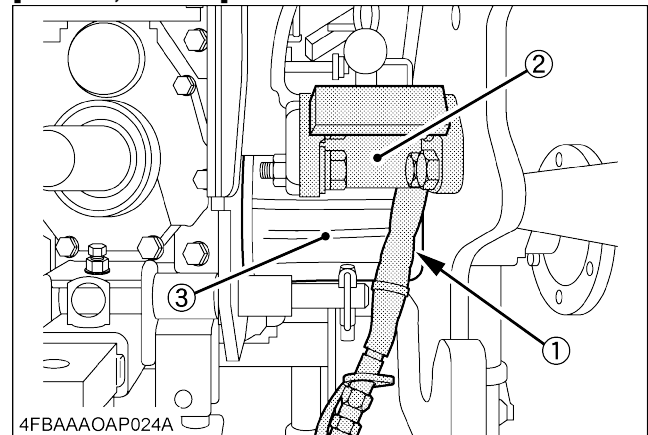
**[BH4972, BH4975]**

(1) Outlet hose

(2) Bracket

(3) Rear axle case

**NOTE :**

- Before attaching the connecting plate, pass the outlet hose between the bracket and rear axle case.

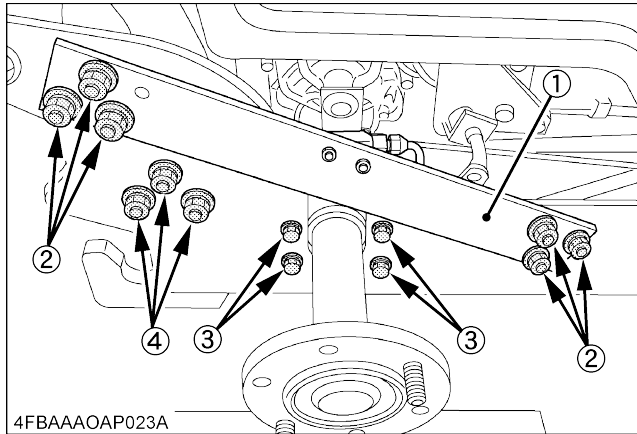

(1) Connecting plate

(2) 6 - M16 x 50 bolts

6 - 5/8 hardened plain washers

6 - M16 spring lock washers

6 - M16 nuts

Tightening torque: 196 to 225 N-m

(20.0 to 23.0 kgf-m, 145 to 166 ft-lbs)

(3) 4 - M12 x 45 or 50 semi bolts (P1.75)

4 - 1/2 hardened plain washers

Tightening torque: 80 N-m

(8.1 kgf-m, 59.0 ft-lbs)

(4) 3 - M16 x 50 bolts

3 - 5/8 hardened plain washers

3 - M16 spring lock washers

3 - M16 nuts

Tightening torque: 196 to 225 N-m

(20.0 to 23.0 kgf-m, 145 to 166 ft-lbs)

**IMPORTANT :**

- Do not tighten fasteners until all components are assembled.
- Finally tighten the fasteners to the specified torque.

[BH4976, BH4988]

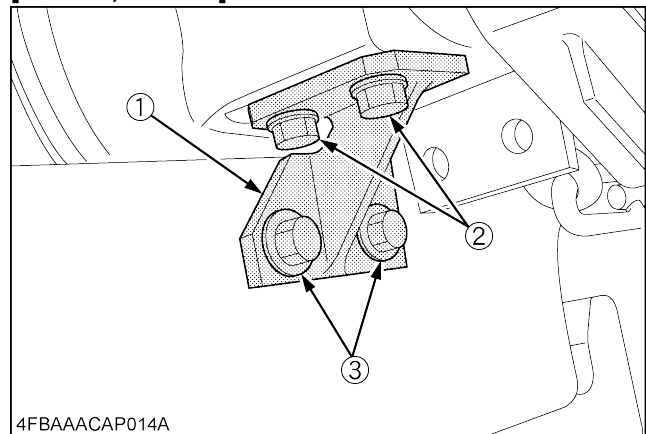

(1) Frame bracket

(2) 2 - M14 x 30 semi bolts

(3) 2 - M14 x 45 bolts

2 - 9/16 hardened plain washers

2 - M14 spring lock washers

2 - M14 nuts

Tightening torque: 124 to 147 N-m

(12.6 to 15.0 kgf-m, 91.2 to 108 ft-lbs)

(4) 3 - M16 x 90 bolts

3 - 5/8 hardened plain washers

3 - M16 spring lock washers

3 - M16 nuts

Tightening torque: 196 to 225 N-m

(20.0 to 23.0 kgf-m, 145 to 166 ft-lbs)

(1) Frame bracket

(2) 2 - M14 x 30 semi bolts

(3) 2 - M14 x 45 bolts

2 - 9/16 hardened plain washers

2 - M14 spring lock washers

2 - M14 nuts

Tightening torque: 124 to 147 N-m

(12.6 to 15.0 kgf-m, 91.2 to 108 ft-lbs)

(4) 3 - M16 x 90 bolts

3 - 5/8 hardened plain washers

3 - M16 spring lock washers

3 - M16 nuts

Tightening torque: 196 to 225 N-m

(20.0 to 23.0 kgf-m, 145 to 166 ft-lbs)

**IMPORTANT :**

- Do not tighten fasteners until all components are assembled.
- Finally tighten the fasteners to the specified torque.

3. Tighten all the nuts and bolts to the specified torque.
4. Reinstall the rear wheels.

**[BH4976, BH4988]**

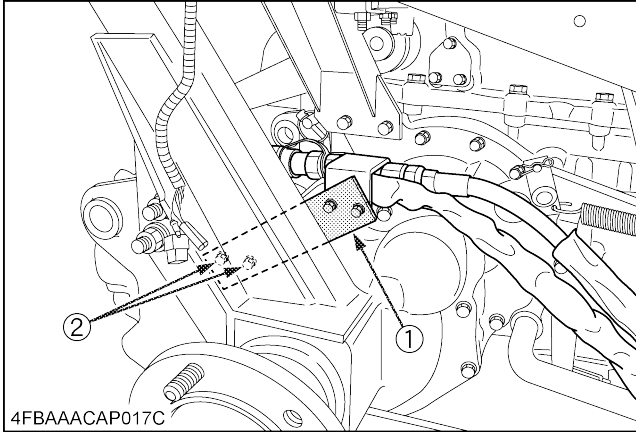

- (1) Connecting plate
  - (2) 2 - M12 x 30 flange bolts  
2 - M12 flange nuts
- Tightening torque: 77.5 to 90.1 N-m  
(7.9 to 9.2 kgf-m, 57.2 to 66.5 ft-lbs)

5. Secure the inlet and outlet hoses with the plastic band in the specified locations.

**IMPORTANT :**

- Hoses pre-installed on the control valve assembly are not securely tightened to ease installation to the hydraulic block. Be sure to securely tighten all hose fittings after installation.
- Adjust the hose fittings so the hoses clear the tractor.

**[BH4972, BH4975]**

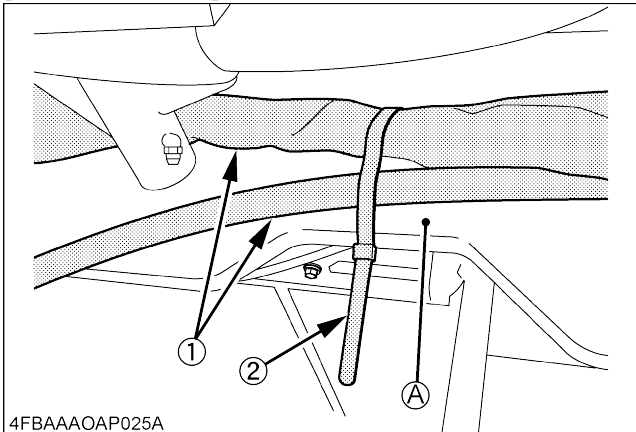

- (1) Hoses
  - (2) Plastic band
- (A) Clamp onto sub frame (inside)

**[BH4976, BH4988]**

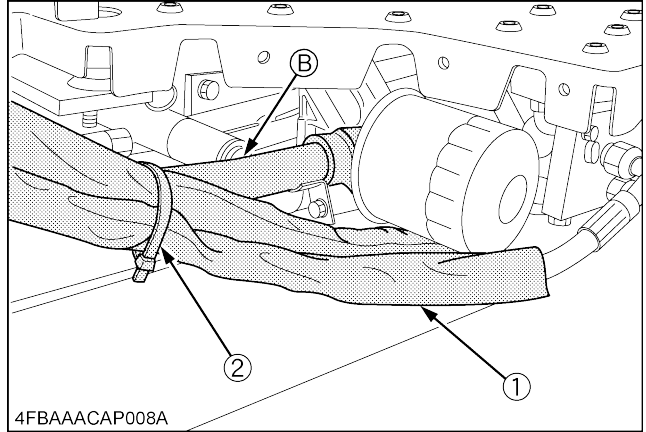

- (1) Hoses
  - (2) Plastic band
- (B) Clamp onto this pipe

**■ CAB Spacer [BH4972]**

1. Attach the cab spacer.

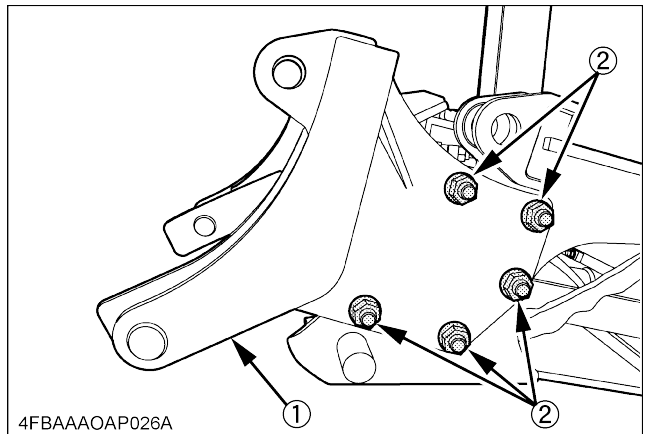

- (1) Cab spacer
  - (2) 5 - M20 x 55 bolts  
10 - 3/4 hardened plain washers  
5 - M20 spring lock washers  
5 - M20 nuts
- Tightening torque: 368 to 431 N-m  
(37.6 to 44.0 kgf-m, 272 to 318 ft-lbs)

## ■ Rear Wheels

1.  Install the right and left rear wheels to the tractor with the bolts and nuts. Tighten the bolts and nuts by the correct tightening torque.

[BH4972, BH4975]

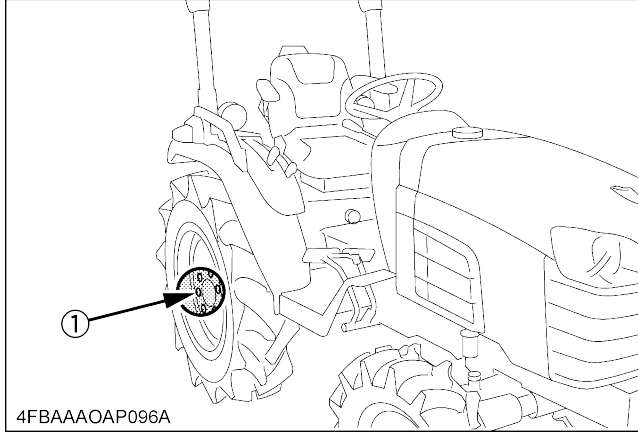

(1) M16 bolts

Tightening torque: 196 to 225 N-m  
(20.0 to 23.0 kgf-m, 145 to 166 ft-lbs)

M16 nuts

Tightening torque: 167 to 191 N-m  
(17.0 to 20.0 kgf-m, 123 to 144 ft-lbs)

[BH4976, BH4988]

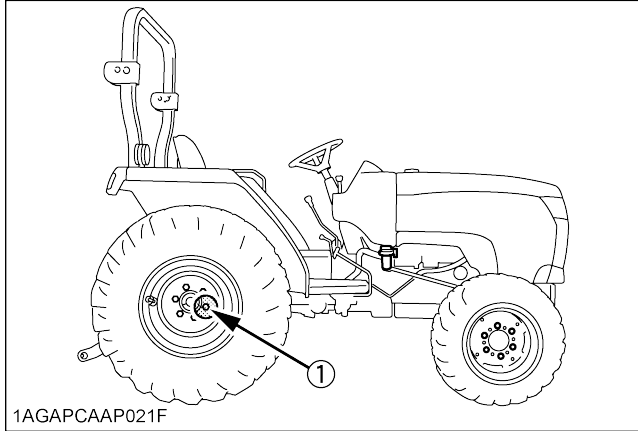

(1) Tightening torque: 215 N-m (22 kgf-m, 160 ft-lbs)

## ASSEMBLY [BH4984]

### ■ Layout of BH77 Backhoe Hydraulic Lines

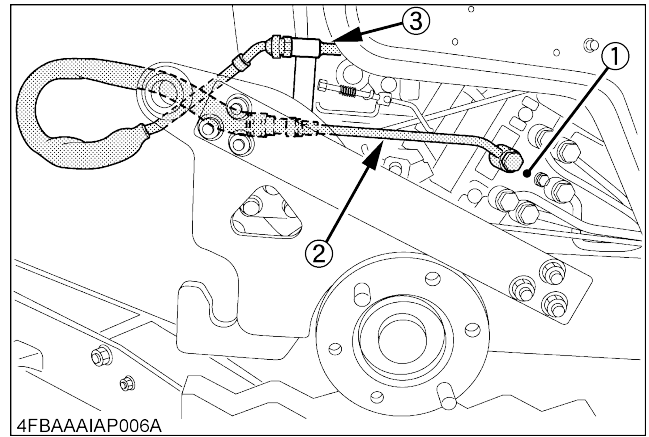

- (1) Front loader valve
- (2) Backhoe inlet pipe
- (3) Backhoe outlet pipe

## Hydraulic Line

1. Disconnect the front loader power beyond pipe.

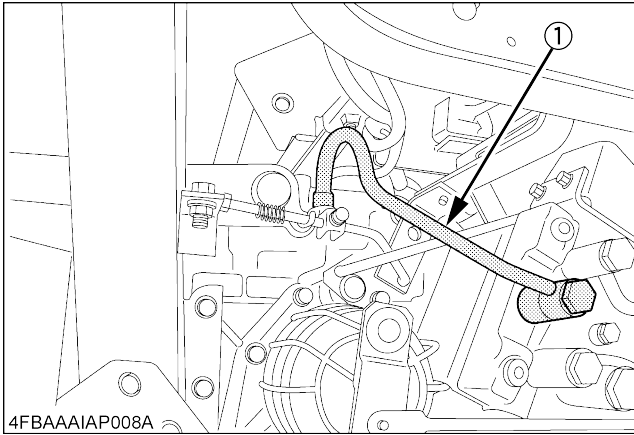

(1) Front loader power beyond pipe

2. Connect the backhoe inlet pipe to the front loader valve. Connect the backhoe outlet pipe to the hydraulic cylinder.

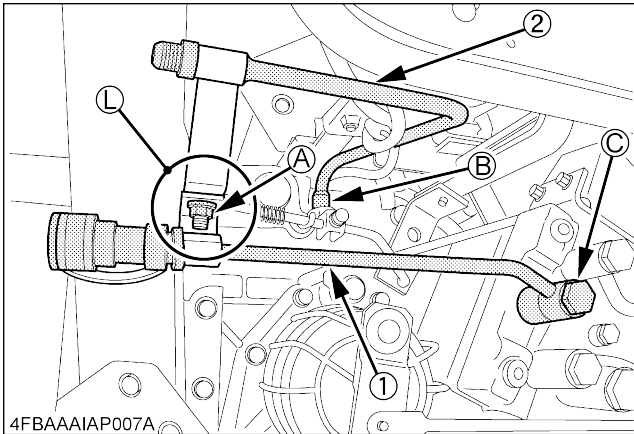

(1) Backhoe inlet pipe  
(2) Backhoe outlet pipe

(L) "On the level"

### NOTE :

- Make sure to apply the two gaskets to the backhoe outlet pipe at the hydraulic cylinder side (B).
- Make sure to apply the two O-rings to the backhoe inlet pipe at the front loader valve side (C).

### IMPORTANT :

- Temporarily tighten the bolt and nut (A) so that the brackets of the inlet and outlet pipes are on the level. Tighten the hydraulic cylinder side (B) of the backhoe outlet pipe and the front loader valve side (C) of the backhoe inlet pipe. And then, remove the bolt and nut (A).

## Sub Frame

1. Lift the sub frame into place using a hoist in the rear and a jack in the front. Attach the sub frame with the supplied nuts and bolts, but do not torque them.

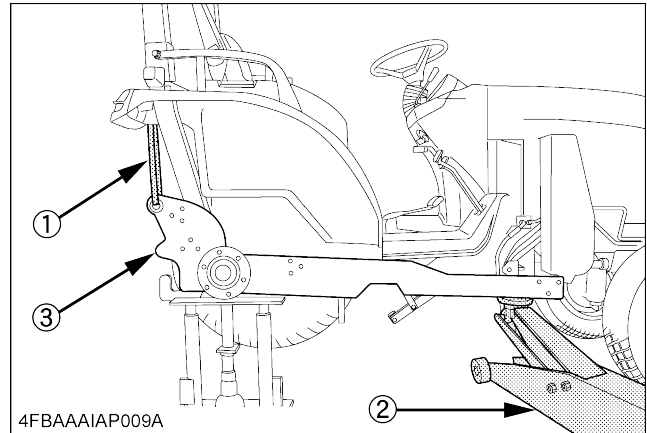

(1) Nylon strap  
(2) Jack  
(3) Sub frame

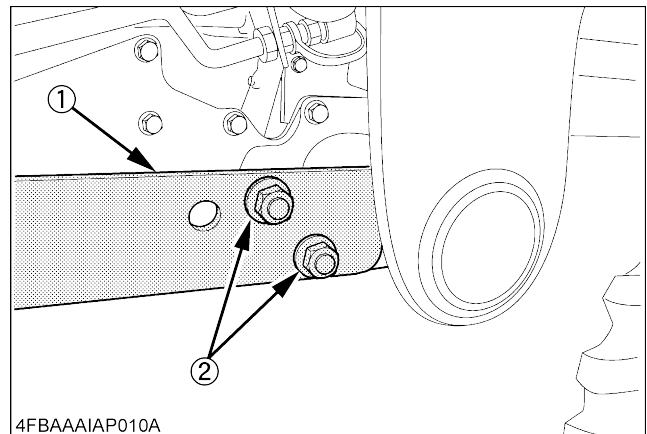

(1) Sub frame  
(2) 2 - M16 x 50 bolts  
4 - 5/8 hardened plain washers  
2 - M16 spring lock washers  
2 - M16 nuts

Tightening torque: 196 to 225 N-m  
(20.0 to 23.0 kgf-m, 145 to 166 ft-lbs)

### IMPORTANT :

- Do not tighten fasteners until all components are assembled.
- Finally tighten the fasteners to the specified torque.

- Using the supplied bolts and nuts, loosely fix the following components to the sub frame:  
 bracket, rear axle case and connecting plate.

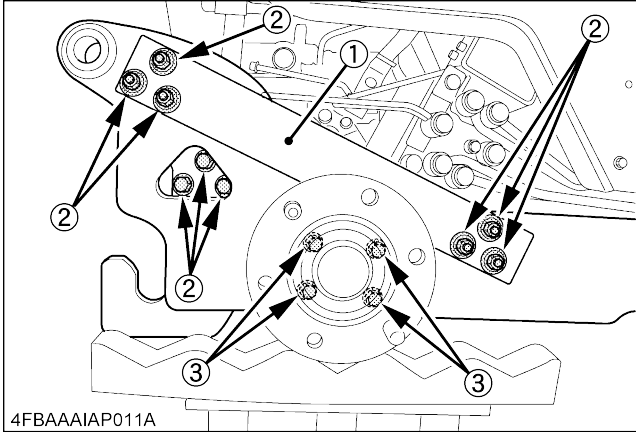

- (1) Connecting plate
- (2) 9 - M16 x 50 bolts  
 18 - 5/8 hardened plain washers  
 9 - M16 spring lock washers  
 9 - M16 nuts
- Tightening torque: 196 to 225 N-m  
 (20.0 to 23.0 kgf-m, 145 to 166 ft-lbs)
- (3) 4 - M12 x 45 sems bolts (P1.75)  
 8 - 1/2 hardened plain washers
- Tightening torque: 63 to 72 N-m  
 (6.4 to 7.4 kgf-m, 46.3 to 53.5 ft-lbs)

**IMPORTANT :**

- Do not tighten fasteners until all components are assembled.
- Finally tighten the fasteners to the specified torque.

- Secure the inlet and outlet pipes with the stay of the sub frame.

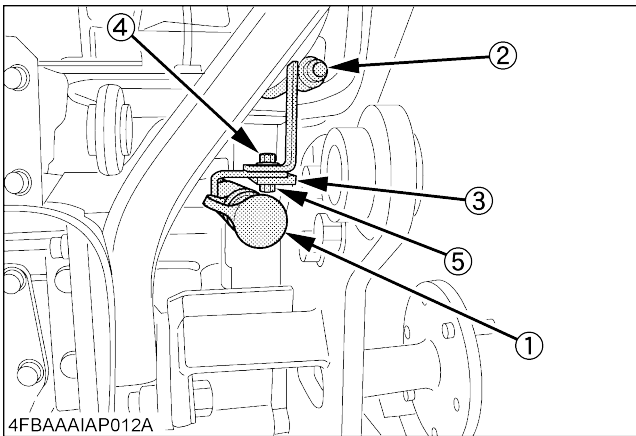

- (1) Inlet pipe
- (2) Outlet pipe
- (3) Stay of sub frame
- (4) M10 x 30 bolt
- (5) Nut

**Operator's Seat**

- Detach the fender stay from the tractor fender. Remove the lights, cup holder and SMV emblem from the fender stay.

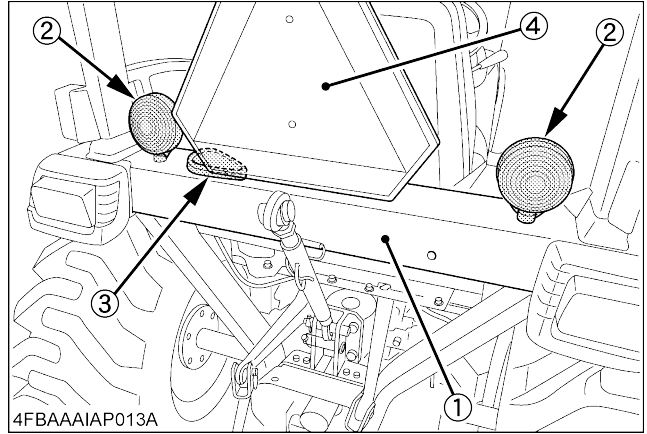

- (1) Fender stay
- (2) Light
- (3) Cup holder
- (4) SMV emblem

- Attach the light to the fender using the light stay. (LH, RH)

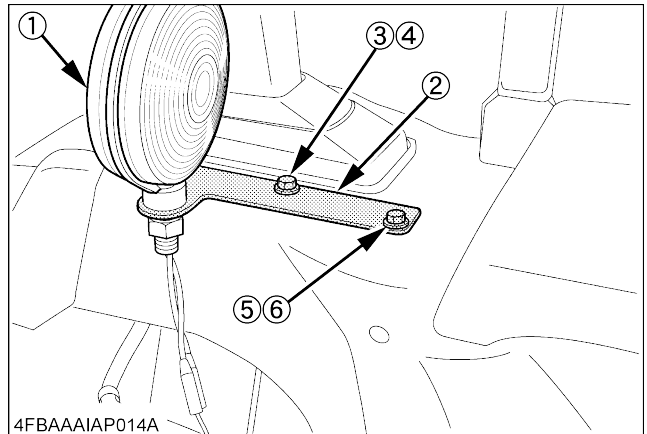

- (1) Light
- (2) Light stay
- (3) M8 x 16 bolt
- (4) M8 nut
- (5) M6 x 14 bolt
- (6) M6 nut

3. Tilt the seat forward, remove the snap pins and disconnect the couplers of the harness. Remove the harness and the seat.

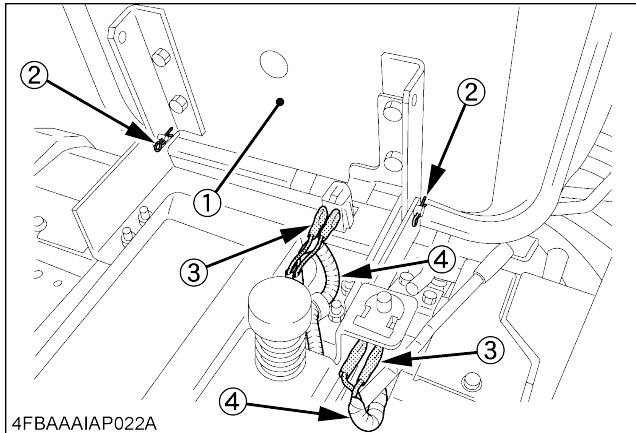

- (1) Seat  
 (2) 2 - Snap pins  
 (3) 4 - Couplers  
 (4) Harness

5. Remove the four bolts from the seat rail stays and remove the seat rail assembly. And then, remove the two bolts.

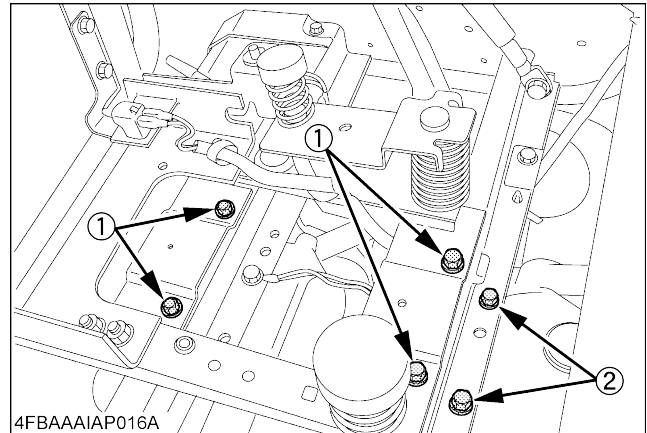

- (1) 4 - Bolts  
 (2) 2 - Bolts

4. Open the tool box, remove the nuts and remove the tool box.

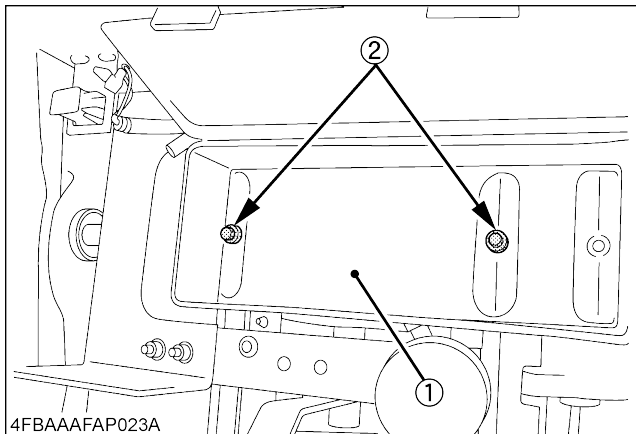

- (1) Tool box  
 (2) 2 - Nuts



6.  Attach the seat support with the sems bolts, spring washers and nuts. Tighten the bolts and nuts by the correct tightening torque.

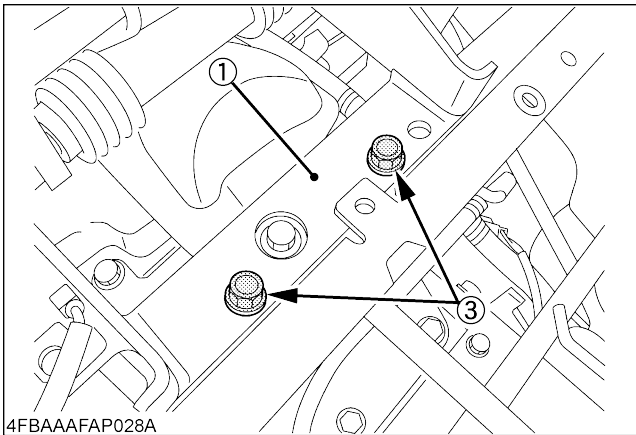
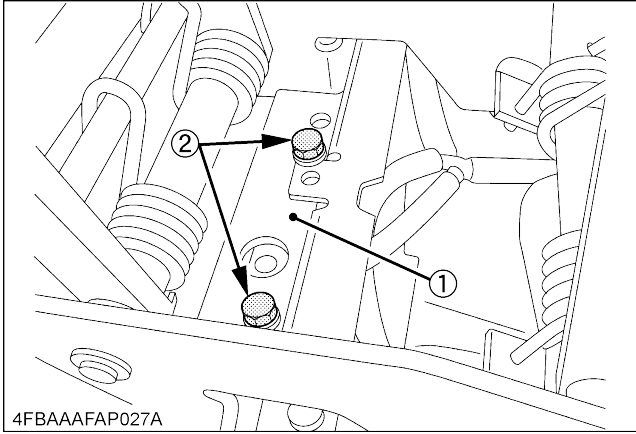

- (1) Seat support  
 (2) 2 - M10 x 25 sems bolts (P1.5)  
 (3) 2 - M10 x 20 nuts  
 Tightening torque: 48.1 to 55.8 N-m  
 (4.9 to 5.7 kgf-m, 35.5 to 41.2 ft-lbs)

7. Attach the SMV socket to the SMV stay with the two nuts. Attach the SMV stay to the seat with the two M8 x 16 bolts (black).

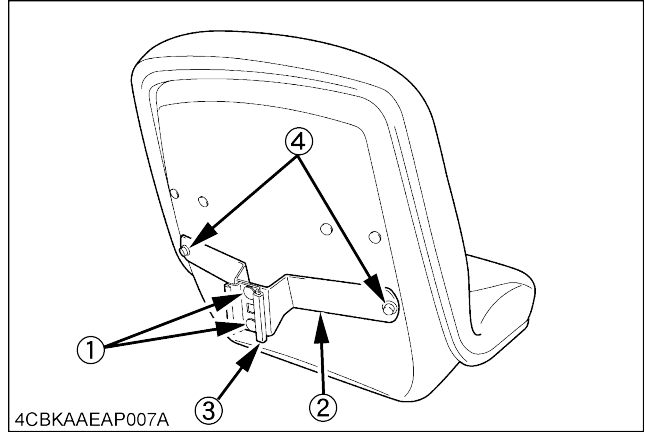

- (1) 2 - Nuts  
 (2) SMV stay  
 (3) SMV socket  
 (4) 2 - M8 x 16 bolts

8. Fit all the parts removed in step 3 back into position.  
 9. Remove the original plates.  
 Attach the seat stay with the sems bolts. Tighten the bolts by the correct tightening torque.

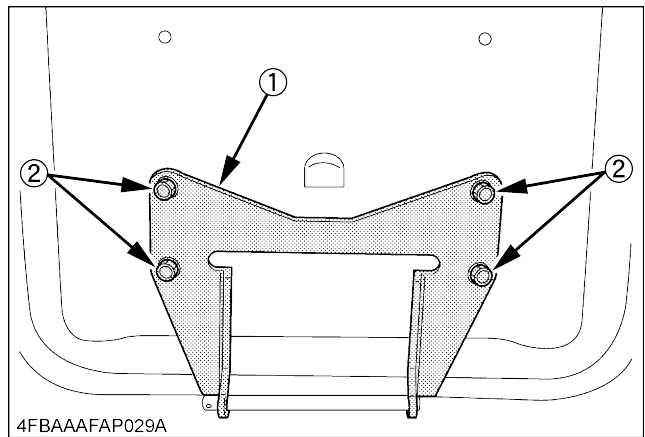

- (1) Seat stay  
 (2) 4 - M8 x 20 sems bolts  
 Tightening torque: 23.6 to 27.4 N-m  
 (2.4 to 2.8 kgf-m, 17.4 to 20.2 ft-lbs)

10.  Attach the seat to the seat adjuster, insert the snap pin to the joint pin surely.

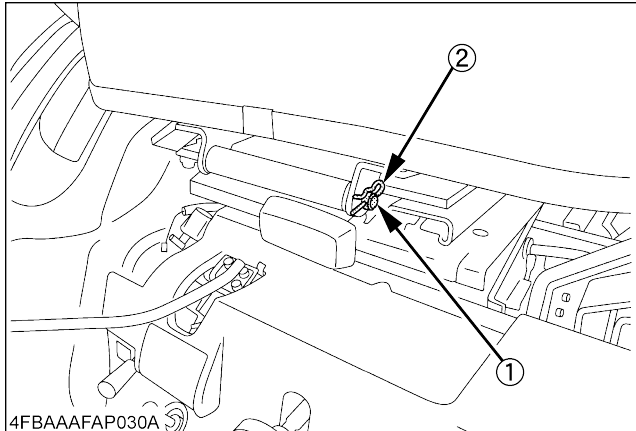

(1) Joint pin  
(2) Snap pin

11. Connect the extension wire harness and secure it by the cord band as shown below.

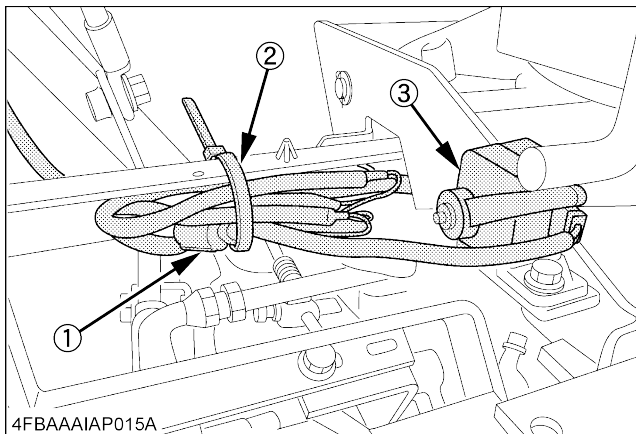

(1) Extension wire harness  
(2) Cord band  
(3) Seat sensor

**NOTE :**

- Connect the wire harness couplers of the extension wire harness to their respective same-color couplers.

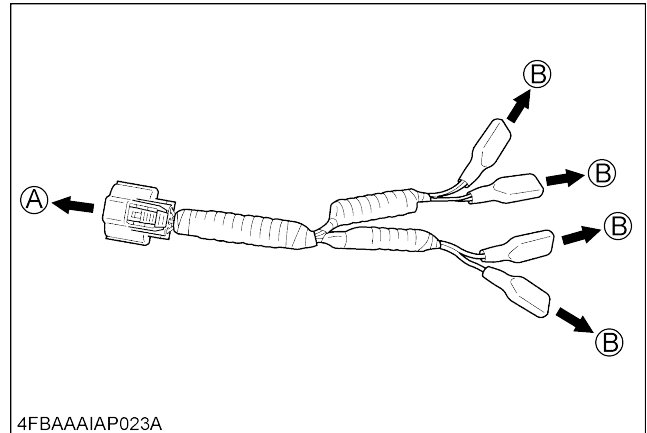

(A) To seat sensor  
(B) To tractor harness

12. Attach the tool box stay to the ROPS frame LH with the U bolts. And then, attach the tool box and cup holder stay with the bolts and nuts, as shown below.

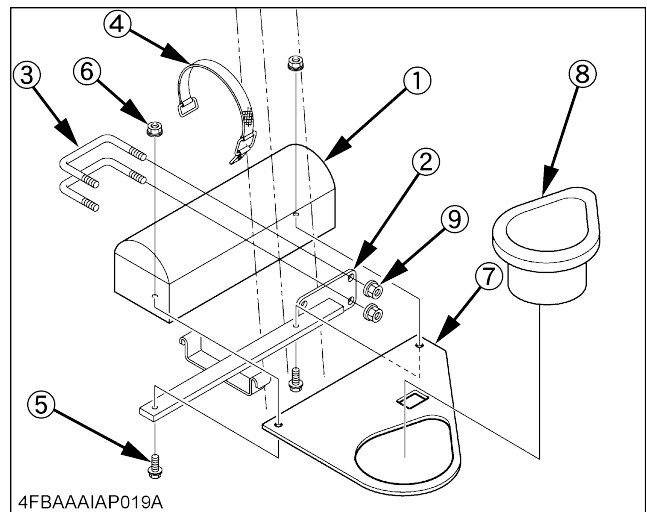

4FBAAAIAP019A

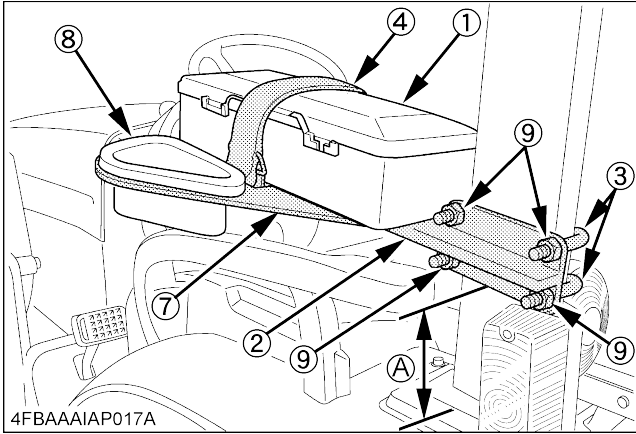

- (1) Tool box
- (2) Tool box stay
- (3) 2 - U bolts
- (4) Band
- (5) 2 - M6 x 25 bolts
- (6) 2 - M6 flange nuts
- (7) Cup holder stay
- (8) Cup holder
- (9) 4 - M10 nuts
- (A) 165 mm (6.5 in.)

**NOTE :**

- Secure the tool box where your hand does not hit against it when moving the levers.

13. Attach the SMV emblem to the SMV socket.

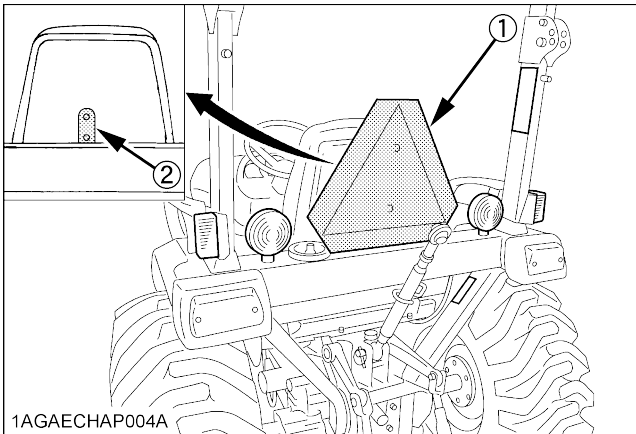

- (1) SMV emblem
- (2) SMV socket

**■ Lever Stopper**

1. Attach the lever stopper to the lever guide.

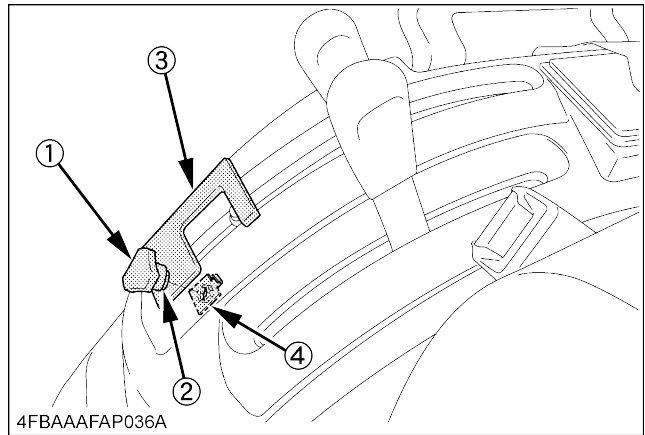

- (1) Knob bolt
- (2) Spring washer
- (3) Lever stopper
- (4) Stopper

2. Apply the important label (7K504-7534-1) as shown below.

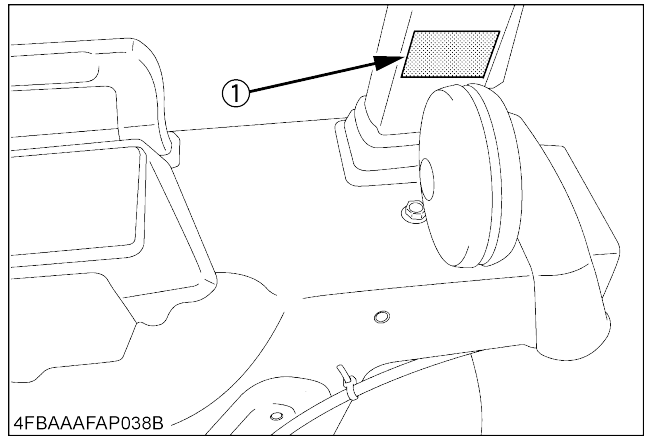

- (1) Important label

## ■ Rear Wheels

1.  Install the right and left rear wheels to the tractor with the bolts and nuts. Tighten the bolts and nuts by the correct tightening torque.

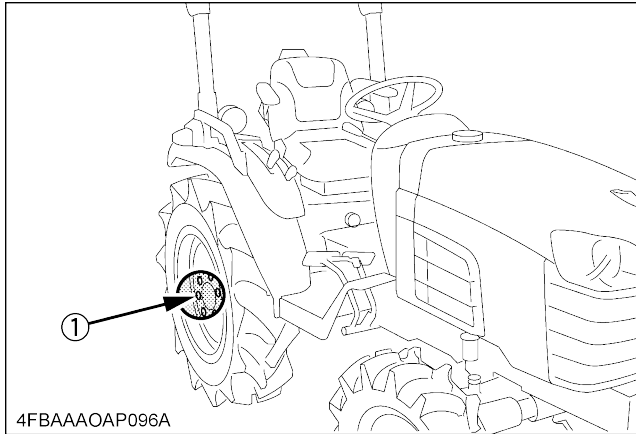

(1) M16 bolts

Tightening torque: 196 to 225 N-m  
(20.0 to 23.0 kgf-m, 145 to 166 ft-lbs)

M16 nuts

Tightening torque: 167 to 191 N-m  
(17.0 to 20.0 kgf-m, 123 to 144 ft-lbs)

## ASSEMBLY [BH4962 BH4963 BH4973]

### ■ Layout of BH77 Backhoe Hydraulic Lines

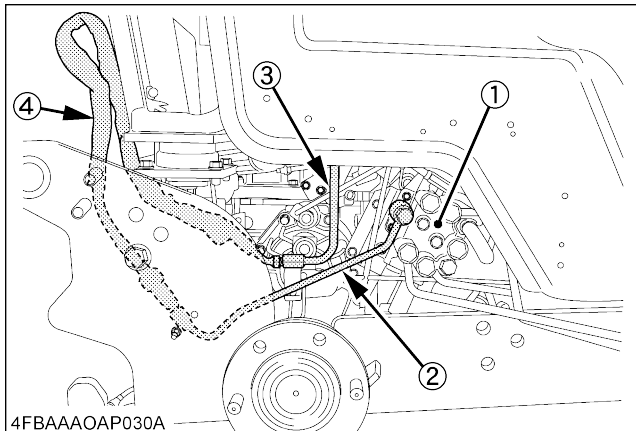

(1) Front loader valve  
(2) Backhoe inlet pipe

(3) Backhoe outlet pipe  
(4) Backhoe outlet hose

## ■ Hydraulic Line

1. Attach the female coupler and the dust plug to the backhoe inlet pipe and male coupler and the dust cap to the backhoe outlet hose.

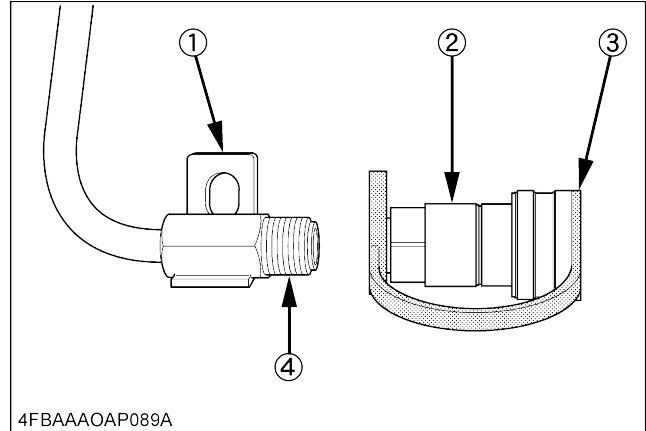

(1) Backhoe inlet pipe

(2) Female coupler (in the BH77 kit)

Tightening torque: 39 to 60 N-m  
(3.9 to 6.1 kgf-m, 29 to 44 lbf-ft)

(3) Dust plug (in the BH77 kit)

(4) Sealing tape

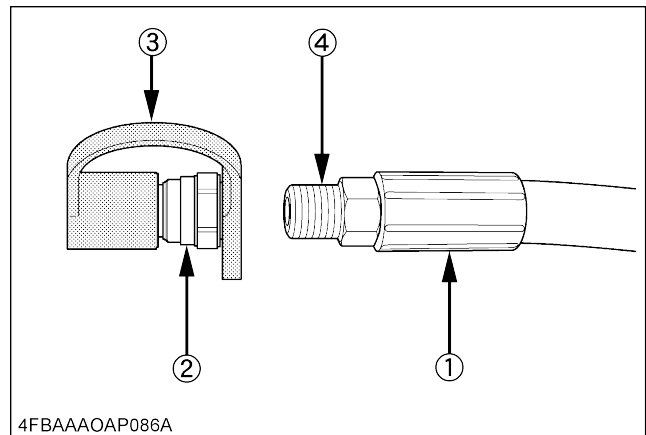

(1) Backhoe outlet hose

(2) Male coupler (in the BH77 kit)

Tightening torque: 39 to 60 N-m  
(3.9 to 6.1 kgf-m, 29 to 44 lbf-ft)

(3) Dust cap (in the BH77 kit)

(4) Sealing tape

#### NOTE :

- Wrap tapered thread of the pipe and hose adapters with sealing tape before assembling.
- When wrapping the sealing tape, leave the 1st and 2nd threads free and wrap 2 to 3 times clockwise pulling tightly.

2. Disconnect the front loader power beyond pipe.

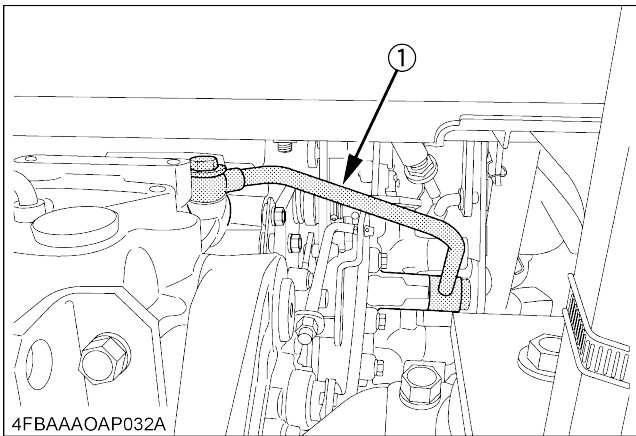
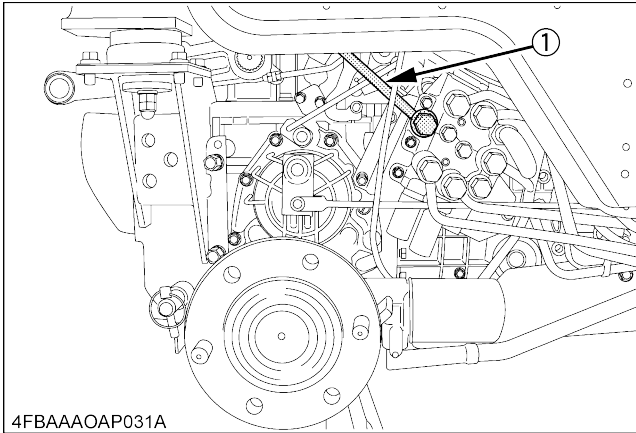

(1) Front loader power beyond pipe

3. Connect the backhoe inlet pipe to the power beyond port of loader valve. Then, connect the backhoe outlet pipe to the hydraulic cylinder and the backhoe outlet hose.

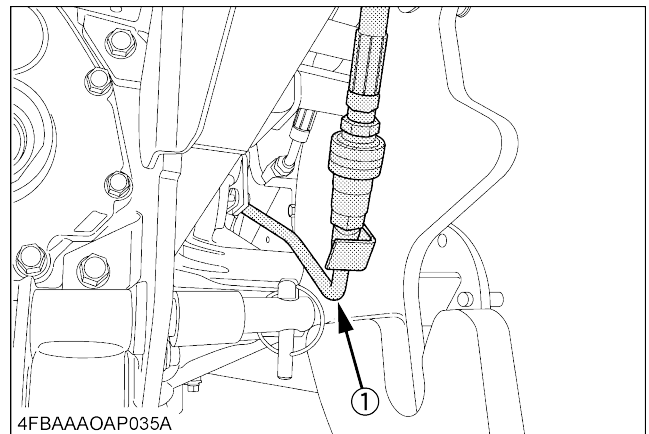
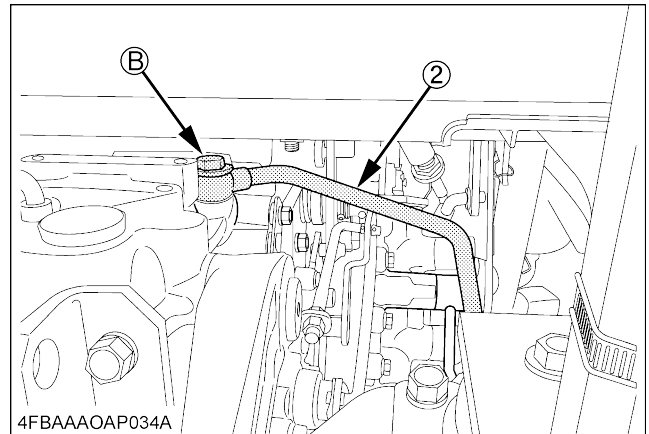
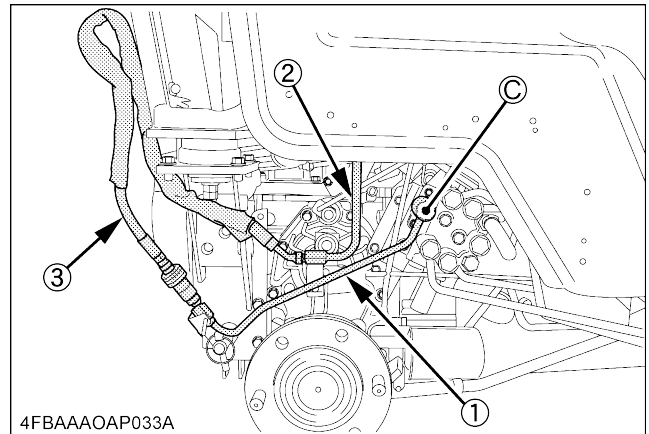

(1) Backhoe inlet pipe  
(2) Backhoe outlet pipe

(3) Backhoe outlet hose

**NOTE :**

- Make sure to apply the two gaskets to the backhoe outlet pipe at the hydraulic cylinder case side (B).
- Make sure to apply the two O-rings to the backhoe inlet pipe at the front loader valve side (C).

4. Attach the sub frame and hose by the cord band as shown below.

[BH4973]

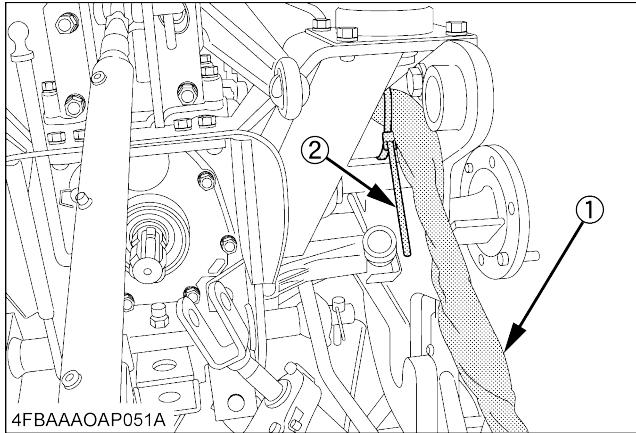

(1) Hose

(2) Cord band

6. A hose should be wired as shown in the following figure.

[BH4973]

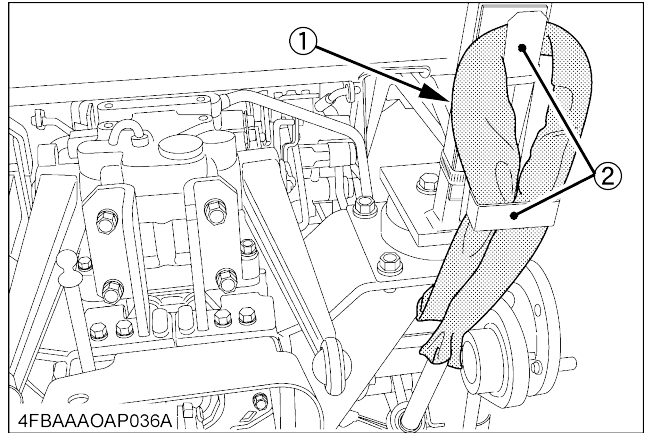

5. Attach the guide and cushion as shown below.

[BH4973]

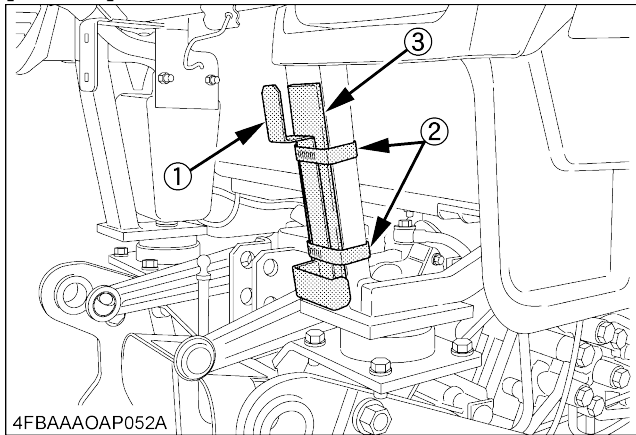

[BH4962, BH4963]

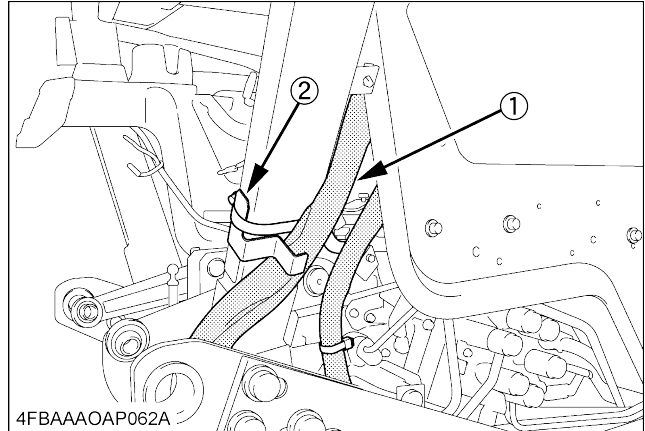

(1) Hose

(2) Guide

[BH4962, BH4963]

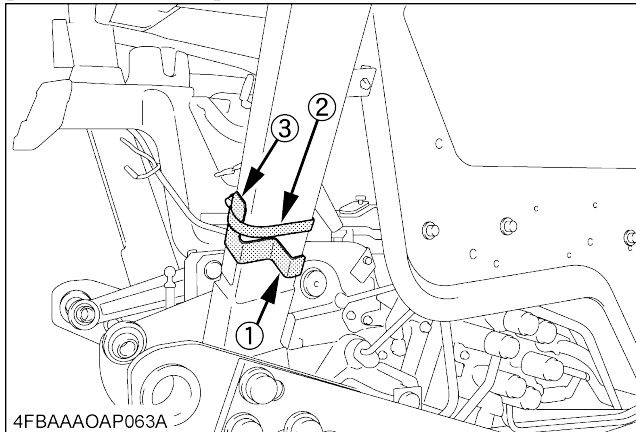

(1) Guide

(2) Band

(3) Cushion

## ■ Sub Frame

1. Lift the sub frame into place using a hoist in the rear and a jack in the front. Attach the sub frame with the supplied nuts and bolts, but do not torque them.

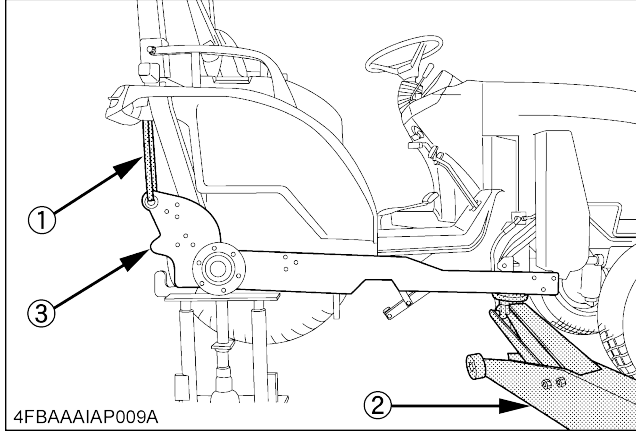

(1) Nylon strap  
(2) Jack

(3) Sub frame

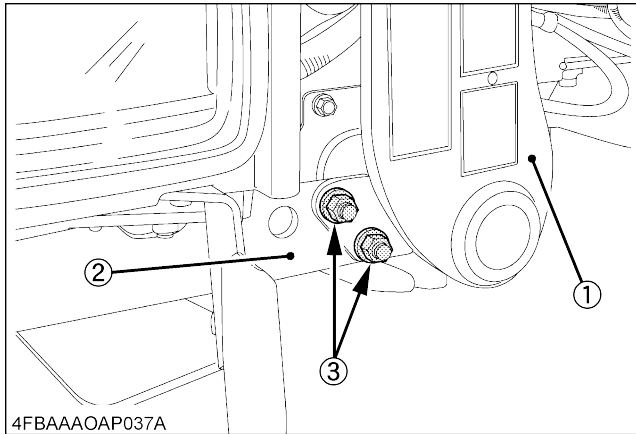

(1) Main frame  
(2) Sub frame  
(3) 2-M16 x 50 bolts  
2-M16 nuts  
4-5/8 hardened plain washers  
2-M16 spring lock washer  
2-M16 nuts

Tightening torque: 196 to 225 N-m  
(20.0 to 23.0 kgf-m, 145 to 166 ft-lbs)

### IMPORTANT :

- Do not tighten fasteners until all components are assembled.
- Finally tighten the fasteners to the specified torque.

2. Using the supplied bolts and nuts, loosely fix the following components to the sub frame: rear axle case and connecting plate.

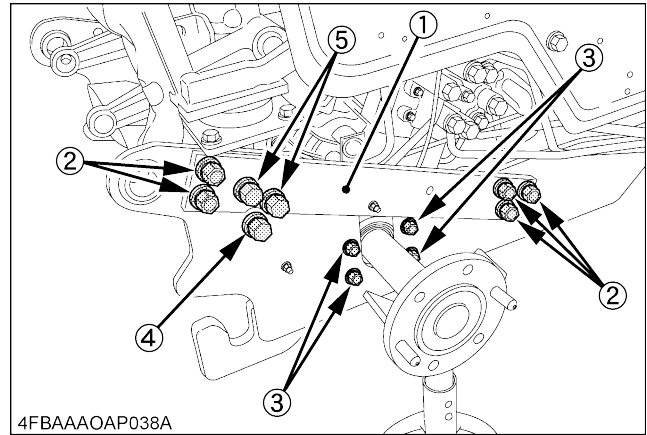

(1) Connecting plate  
(2) 5 - M16 x 50 bolts  
5 - 5/8 hardened plain washers  
5 - M16 spring lock washers  
5 - M16 nuts

Tightening torque: 196 to 225 N-m

(20.0 to 23.0 kgf-m, 145 to 166 ft-lbs)

(3) 4 - M12 x 50 semi bolts  
4 - 1/2 hardened plain washers

Tightening torque: 80 N-m

(8.1 kgf-m, 59.0 ft-lbs)

(4) 1 - M16 x 130 bolt  
1 - 5/8 hardened plain washer

(5) 2 - M16 x 140 bolts  
2 - 5/8 hardened plain washers

Tightening torque: 196 to 225 N-m

(20.0 to 23.0 kgf-m, 145 to 166 ft-lbs)

### IMPORTANT :

- Do not tighten fasteners until all components are assembled.
- Finally tighten the fasteners to the specified torque.

- Secure the outlet pipe with the connecting plate, and the inlet pipe with the sub frame.

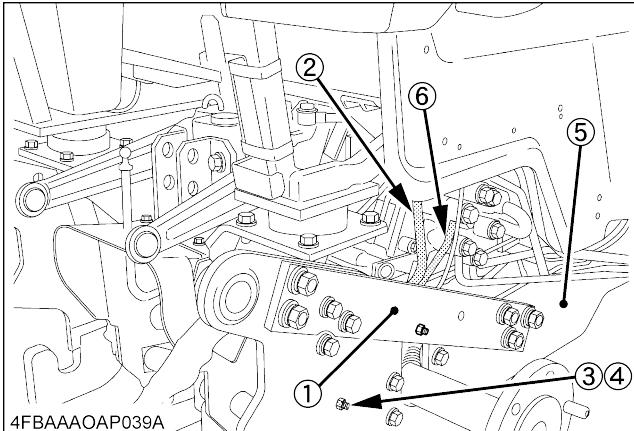

- |                      |                |
|----------------------|----------------|
| (1) Connecting plate | (5) Sub frame  |
| (2) Outlet pipe      | (6) Inlet pipe |
| (3) 1 - M8 x 30 bolt |                |
| (4) 1 - M8 nut       |                |

### ■ Hazard Light, Tool Box and SMV Emblem [BH4962, BH4963]

- Detach the fender stay from the tractor fender.

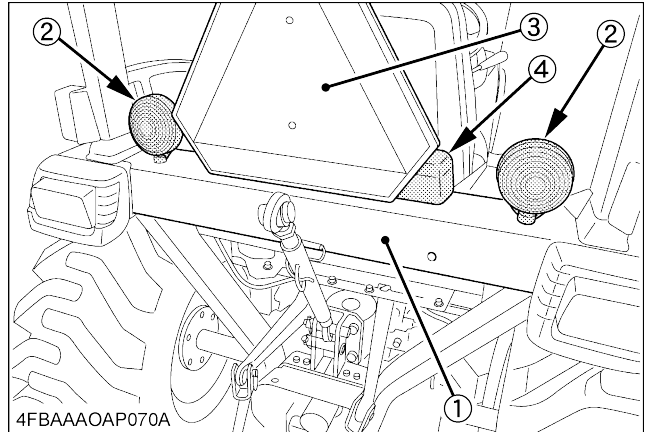

- |                  |
|------------------|
| (1) Fender stay  |
| (2) Hazard light |
| (3) SMV emblem   |
| (4) Tool box     |

- Detach the hazard light, tool box and SMV emblem from the fender stay.
- Attach the hazard light to the fender with the light stay (LH and RH).

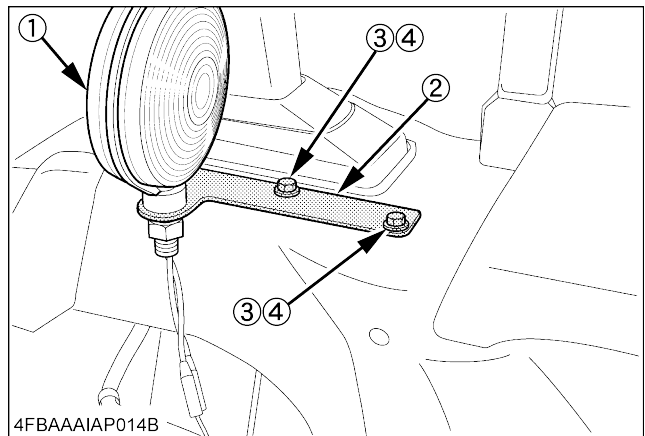

- |                  |
|------------------|
| (1) Hazard light |
| (2) Light stay   |
| (3) M8 x 16 bolt |
| (4) M8 nut       |



- Attach the tool box to the left side of the ROPS with the tool box stay.

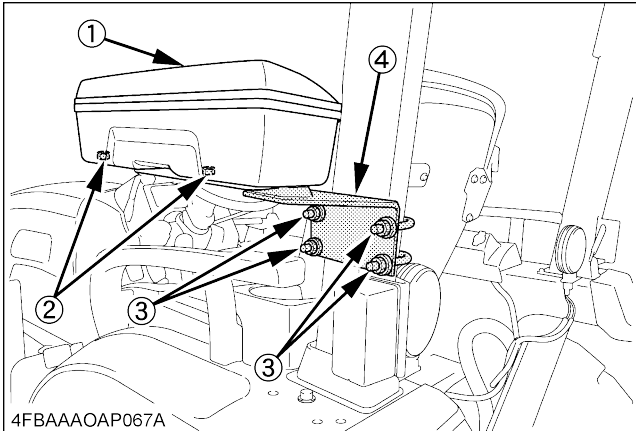

- (1) Tool box
- (2) 2-M8 x 25 bolts
- (3) 2-U bolts  
4-M10 nuts

Tightening torque: 10 to 15 N-m  
(1.0 to 1.5 kgf-m, 7.3 to 11 ft-lbs)

- (4) Tool box stay

**NOTE :**

- Secure the tool box where your hand does not hit against it when moving the levers.

- Attach the SMV emblem to the SMV socket of the backhoe.

**IMPORTANT :**

- When traveling on the road, be sure to attach the SMV emblem.

**Operator's Seat [BH4962, BH4963]  
[B2650ROPS, B3350ROPS (BH4962)]**

- Draw out the snap pin and joint pin, and take out the operator's seat.

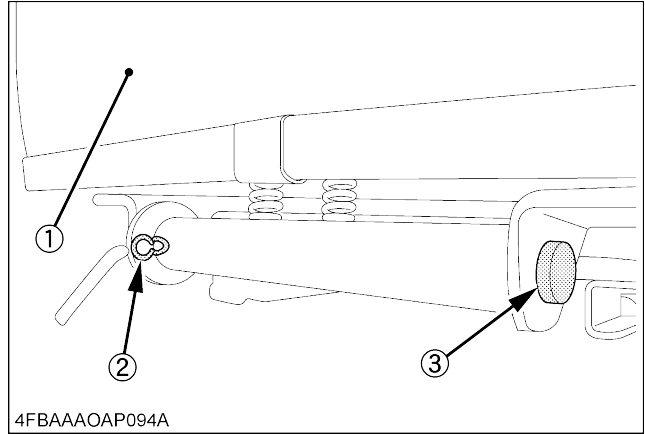

- (1) Operator's seat
- (2) Snap pin
- (3) Joint pin

- Disconnect the sensor harness coupler and take out the sensor.

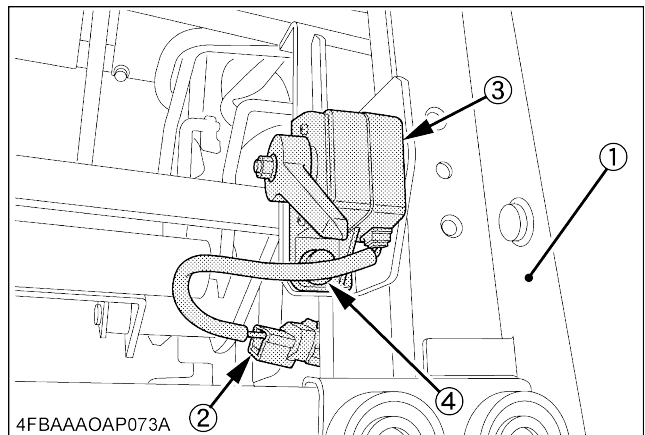

- (1) Seat support assembly
- (2) Sensor harness coupler
- (3) Sensor
- (4) M6 semi bolt

3. Remove the 4 bolts and detach the seat support assembly.

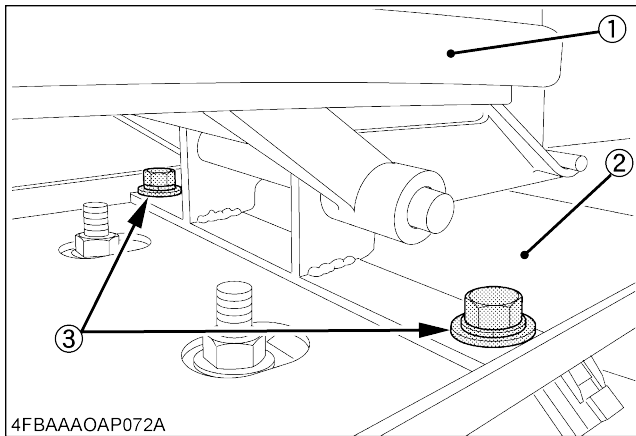
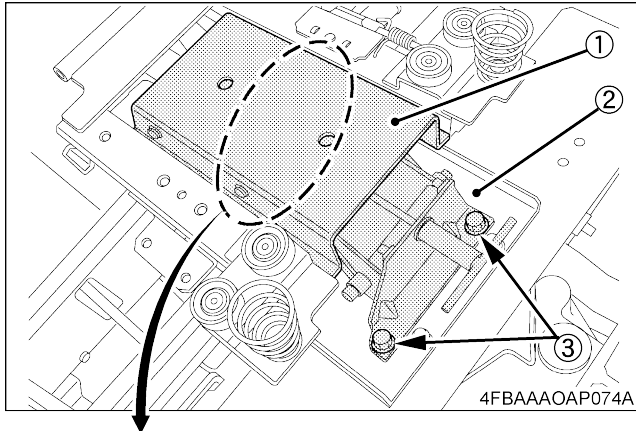

- (1) *Seat support assembly*  
 (2) *Reinforcing stay*  
 (3) *4-M8 W sems bolts*

4. Remove the 4 nuts, and detach the seat adjuster assembly and seat belt stay from the seat support assembly.

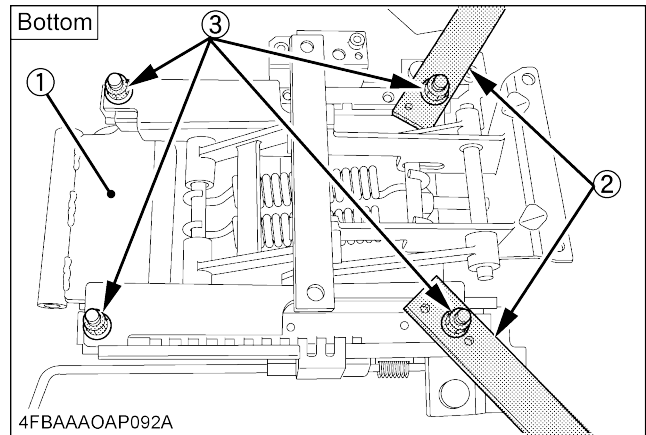

- (1) *Seat adjuster assembly*  
 (2) *Seat belt stay*  
 (3) *4-M8 flange nuts*

5.  Attach the seat adjuster assembly and seat belt stay onto the rotating seat support assembly in the kit as shown below. Tighten the flange nuts by the correct tightening torque.

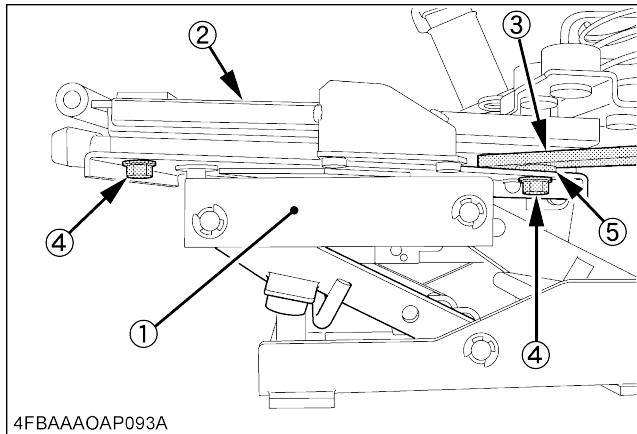
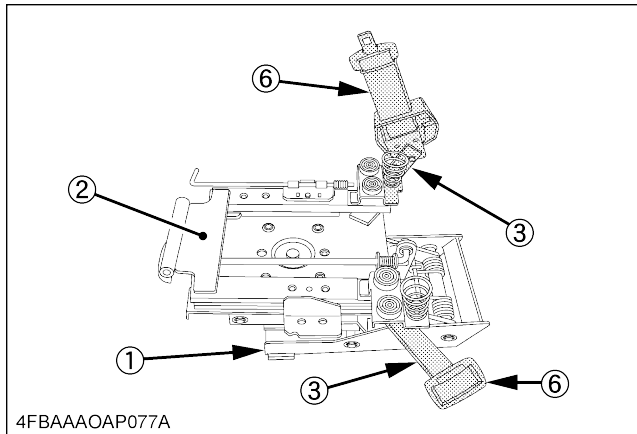

- (1) Rotating seat support assembly
  - (2) Seat adjuster assembly
  - (3) Seat belt stay (original)
  - (4) 4-M10 flange nuts (original)
- Tightening torque: 48.1 to 55.8 N-m  
(4.9 to 5.7 kgf-m, 35.5 to 41.2 ft-lbs)
- (5) 2-Collars
  - (6) Seat belt (original)

**IMPORTANT :**

- Install the collar onto the bottom of the seat belt stay.

6. Tighten up the bolt and lock it with the nut, as shown below.

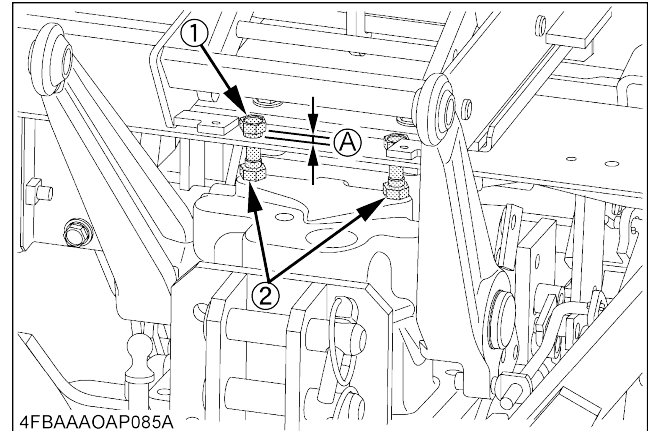

- (1) 2-Bolts (M10 x 1.5)
  - (2) 2-Nuts (M10 x 1.5)
- (A) 2 to 4 mm

7. Remove the 4 nuts from the tractor in the following figure.

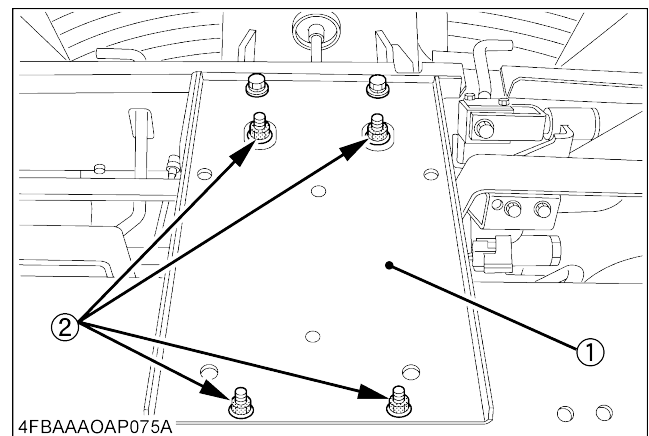

- (1) Reinforcing stay.
- (2) 4-M8 flange nuts

8. Install the collar to the reinforcing stay in the position as shown below.

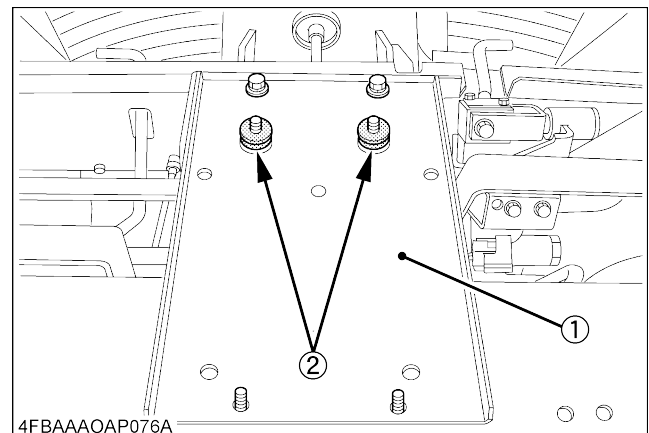

- (1) Reinforcing stay
- (2) 2-Collars

9.  Attach the rotating seat support assembly to the tractor as shown below. Tighten the flange nuts by the correct tightening torque.

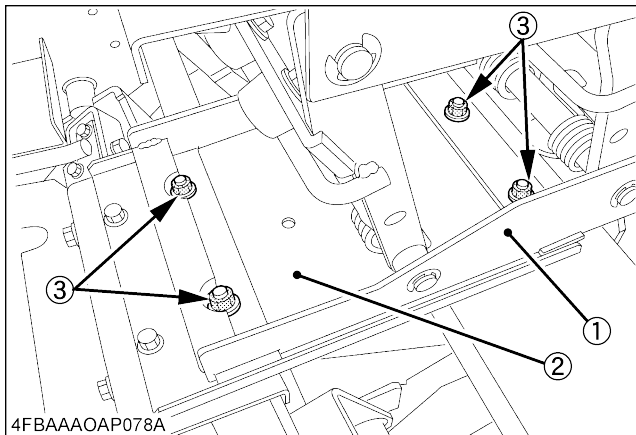

- (1) Rotating seat support assembly  
 (2) Reinforcing stay  
 (3) 4-M8 flange nuts (original)

Tightening torque: 23.6 to 27.4 N-m  
 (2.4 to 2.8 kgf-m, 17.4 to 20.2 ft-lbs)

10. Attach the sensor to the right side of the rotating seat support assembly. Reconnect sensor harness.

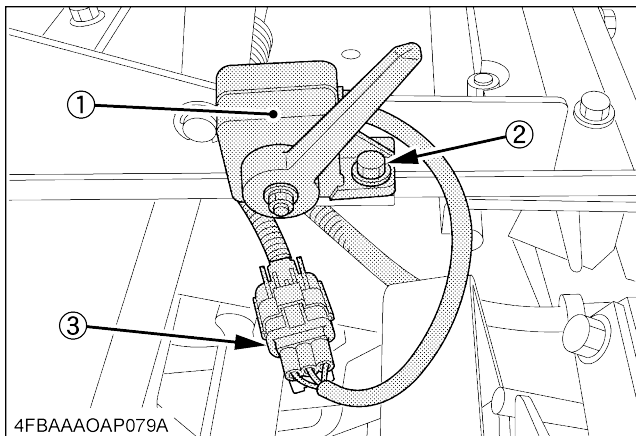

- (1) Sensor (original)  
 (2) M6 semi bolt (original)  
 (3) Sensor harness (original)

11.  Attach the seat to the seat adjuster, insert the snap pin to the joint pin surely.

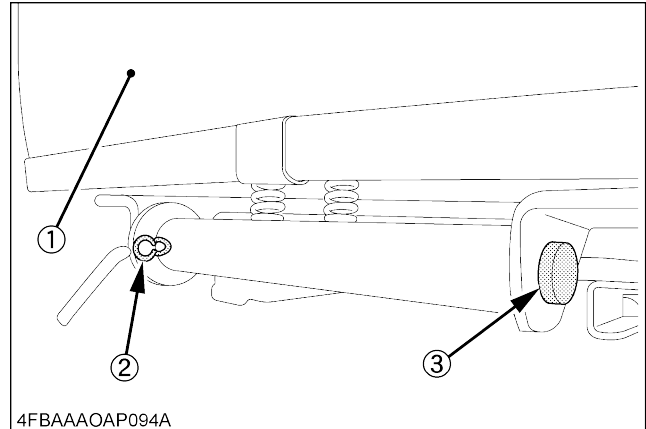

- (1) Operator's seat  
 (2) Snap pin  
 (3) Joint pin

### [B3350SU (BH4963)]

1. Tilt the operator's seat forward, and disconnect the sensor wire harness coupler. Next draw out the snap pins and take out the sensor assembly and the operator's seat.

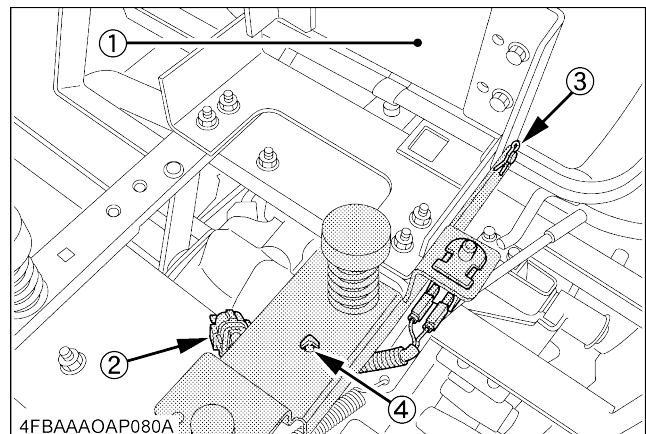

- (1) Operator's seat  
 (2) Coupler  
 (3) Snap pin  
 (4) Sensor assembly

2. Replace the seat stay, which is behind the seat, with the one in the kit.

**[BEFORE]**

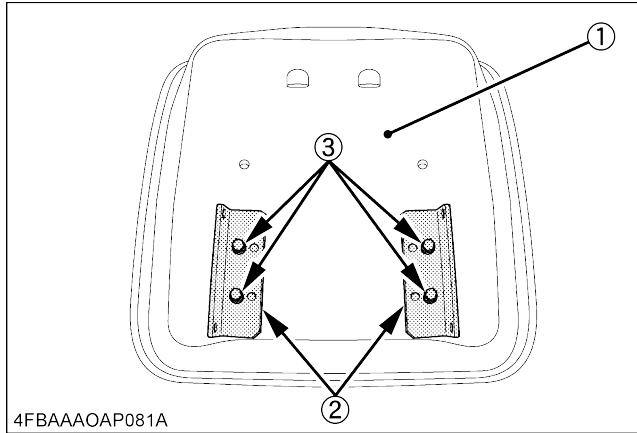

- (1) Operator's seat                      (3) 4-M8 sems bolts  
 (2) Seat stay

5. Attach the seat stay with the sems bolts. Tighten the bolts by the correct tightening torque.

**[AFTER]**

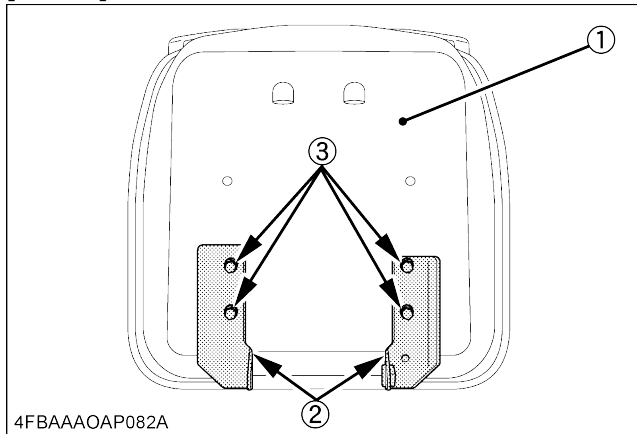

- (1) Operator's seat  
 (2) Seat stay  
 (3) 4-M8 sems bolts (original)  
 Tightening torque: 23.6 to 27.4 N-m  
 (2.4 to 2.8 kgf-m, 17.4 to 20.2 ft-lbs)

3. Remove the nuts and detach the seat support assembly. Then remove the bolts and detach the seat belt and the seat belt stay.

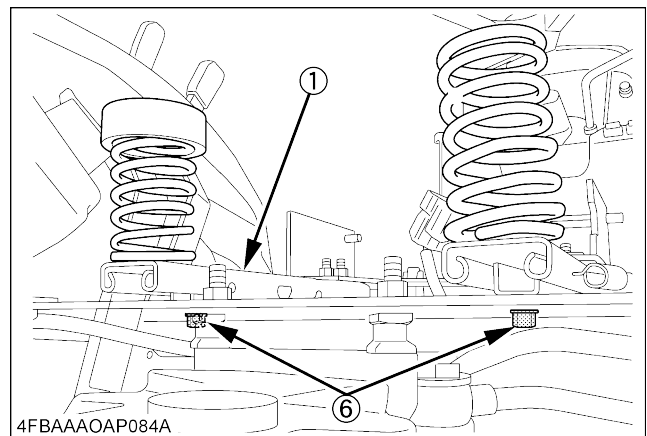
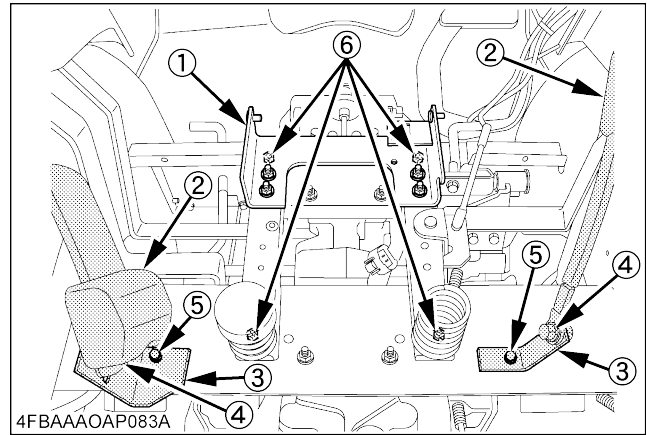

- (1) Seat support assembly                      (4) 2-M10 flange bolts  
 (2) Seat belt                                      (5) 2-M8 sems bolts  
 (3) Seat belt stay                                (6) 4-M8 nuts

**NOTE :**

- Use the stay bolt holes, two at each stay, which are located at the rear and center as shown above.

4. Remove the 4 lock nuts as shown below.

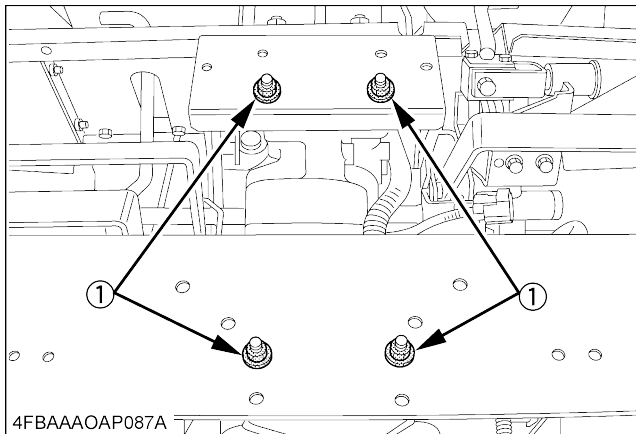

(1) 4-M8 flange nuts

5. Place the reinforcing stay in position and fix it with the bolts.

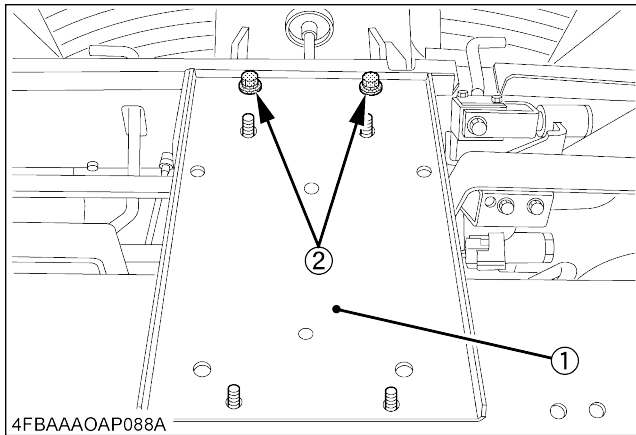

(1) Reinforcing stay  
(2) 2-M8 W sems bolts

6.  Attach the seat belt to the seat belt stay (LH and RH) as illustrated below. Tighten the bolts by the correct tightening torque.

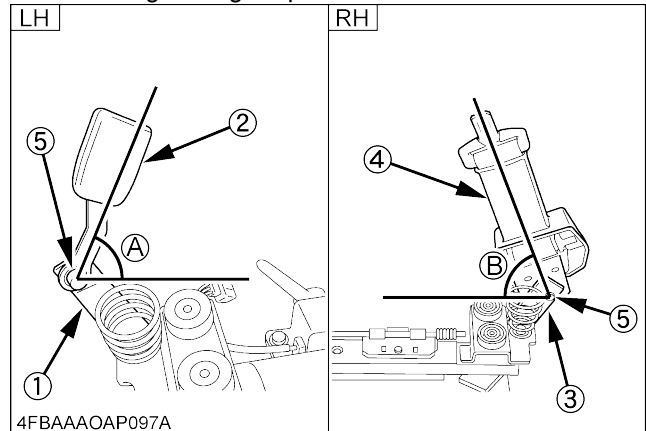

(1) Seat belt stay LH  
(2) Seat belt LH (original)  
(3) Seat belt stay RH  
(4) Seat belt RH (original)  
(5) 2-M10 x 25 sems bolts

(A) 55 to 65 deg.  
(B) 55 to 65 deg.

Tightening torque: 48.1 to 55.8 N-m

(4.9 to 5.7 kgf-m, 35.5 to 41.2 ft-lbs)

7.  Attach the seat adjuster assembly and seat belt stay and seat belt onto the rotating seat support assembly as shown below. Tighten the flange nuts by the correct tightening torque.

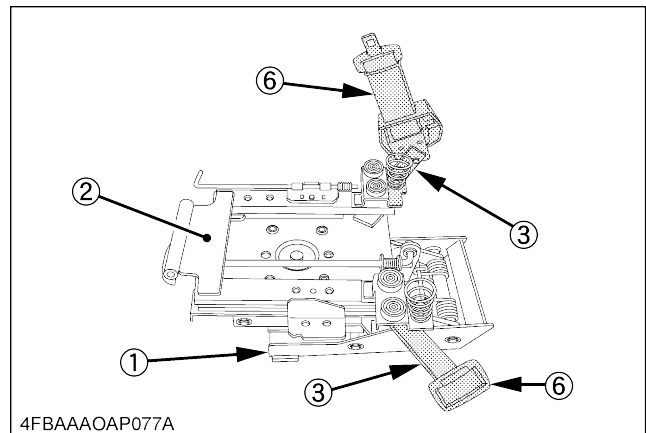

4FBAAA0AP077A

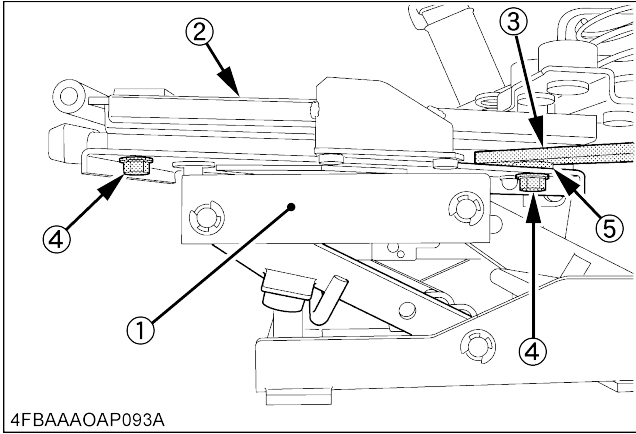

- (1) Rotating seat support assembly
  - (2) Seat adjuster assembly
  - (3) Seat belt stay
  - (4) 4-M10 flange nuts
- Tightening torque: 48.1 to 55.8 N-m  
(4.9 to 5.7 kgf-m, 35.5 to 41.2 ft-lbs)
- (5) 2-Collars
  - (6) Seat belt (original)

**IMPORTANT :**

- Install the collar onto the bottom of the seat belt stay.

8. Tighten up the bolt and lock it with the nut, as shown below.

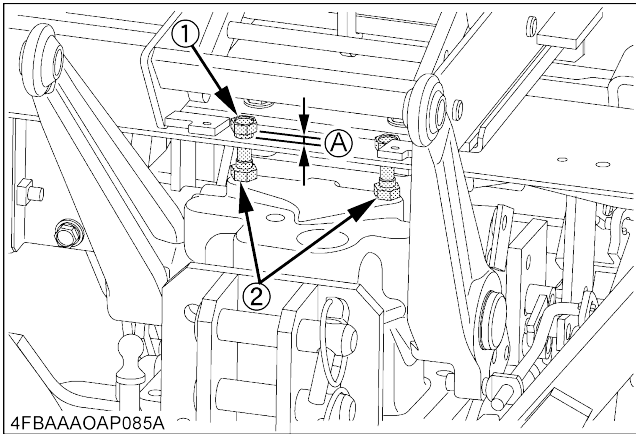

- (1) 2-Bolts (M10 x 1.5)
- (2) 2-Nuts (M10 x 1.5)
- (A) 2 to 4 mm

9. Install the collar to the reinforcing stay in the position as shown below.

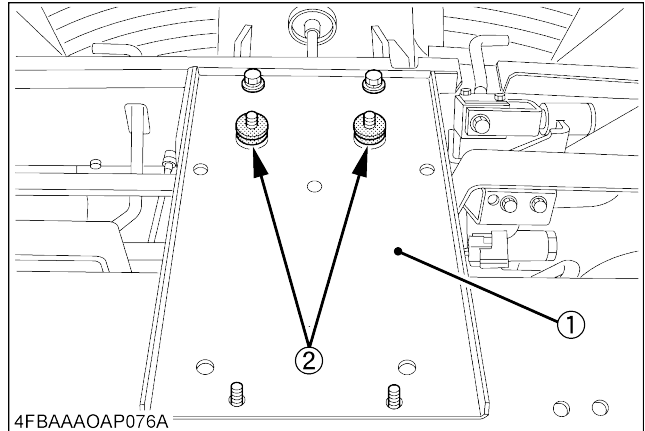

- (1) Reinforcing stay
- (2) 2-Collars

10. Attach the rotating seat support assembly to the tractor as shown below. Tighten the flange nuts by the correct tightening torque.

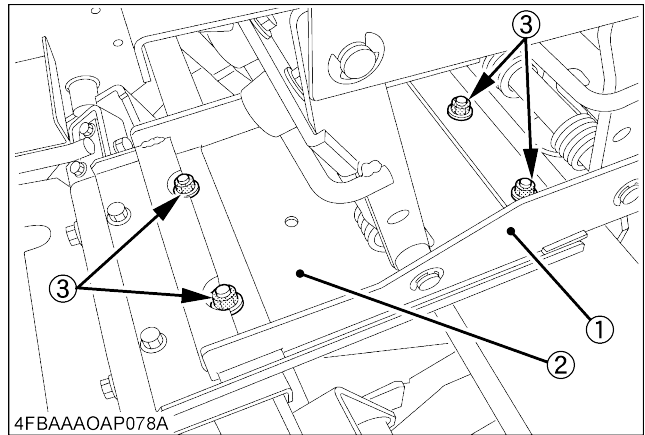

- (1) Rotating seat support assembly
- (2) Reinforcing stay
- (3) 4-M8 flange nuts (original)

Tightening torque: 23.6 to 27.4 N-m  
(2.4 to 2.8 kgf-m, 17.4 to 20.2 ft-lbs)

11. Attach the sensor in the kit to the right side of the rotating seat support assembly. Connect sensor harness.

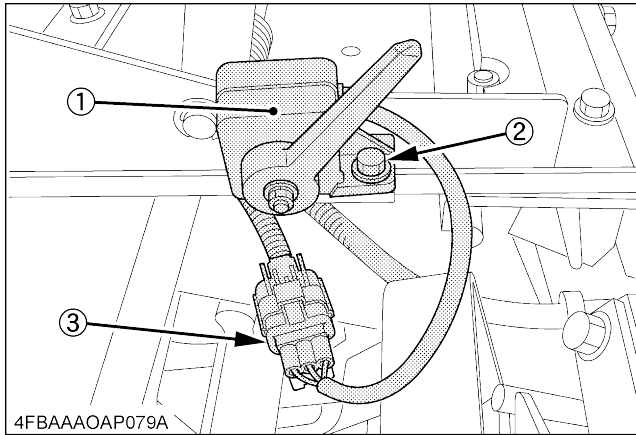

- (1) Sensor  
 (2) M6 semi bolt  
 (3) Sensor harness

12.  Attach the seat to the seat adjuster, insert the snap pin to the joint pin surely.

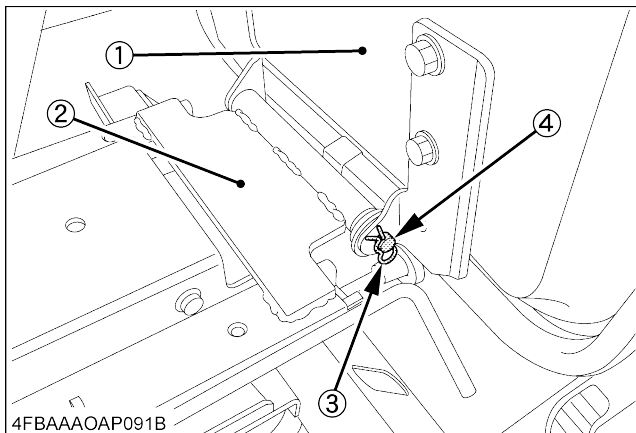

- (1) Operator's seat  
 (2) Rotating seat support  
 (3) Snap pin  
 (4) Joint pin

### Label [BH4962, BH4963]

Apply the label in the kit to the fender RH as shown below.

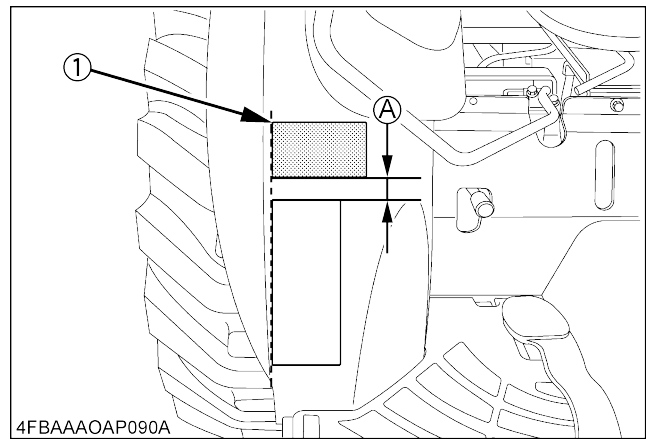

- (1) Label (IMPORTANT)      (A) 10 to 20 mm

### NOTE :

- Wipe off dust and oil completely before applying.

### CAB Spacer [BH4973]

1. Attach the cab spacer.

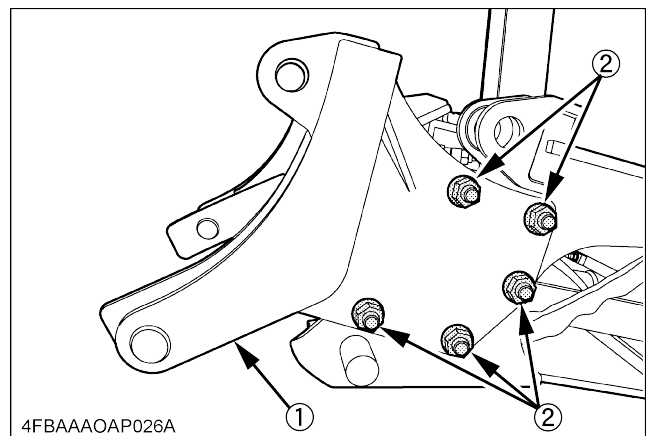

- (1) Cab spacer  
 (2) 5 - M20 x 55 bolts  
 10 - 3/4 hardened plain washers  
 5 - M20 spring lock washers  
 5 - M20 nuts

Tightening torque: 368 to 431 N-m  
 (37.6 to 44.0 kgf-m, 272 to 318 ft-lbs)



## ■ Rear Wheels

1.  Install the right and left rear wheels to the tractor with the bolts and nuts. Tighten the bolts and nuts by the correct tightening torque.

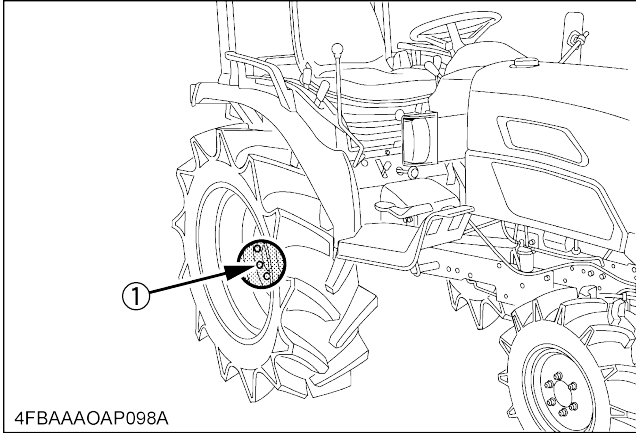

(1) *M16 bolts*

Tightening torque: 196 to 225 N-m  
(20.0 to 23.0 kgf-m, 145 to 166 ft-lbs)

*M16 nuts*

Tightening torque: 167 to 191 N-m  
(17.0 to 20.0 kgf-m, 123 to 144 ft-lbs)

## ASSEMBLY [BH4985]

1. Detach the rear tire from the tractor.

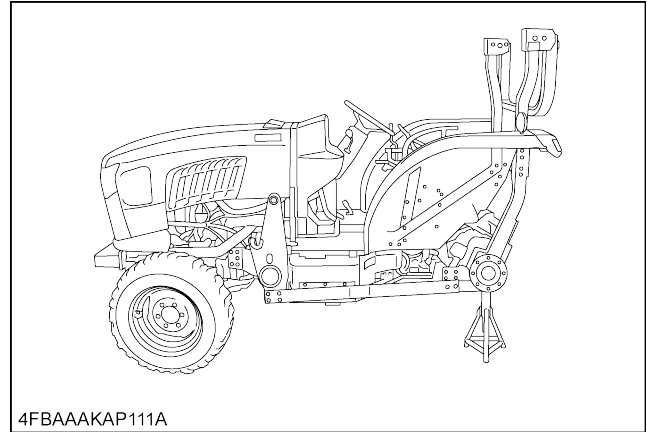

## ■ Sub Frame

1. Detach the front loader sub frame.

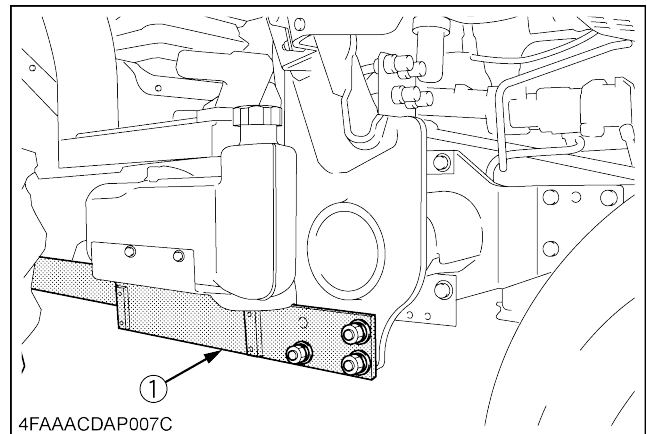

(1) *Sub frame*

2. Detach the collar and attach the rear bracket in place.

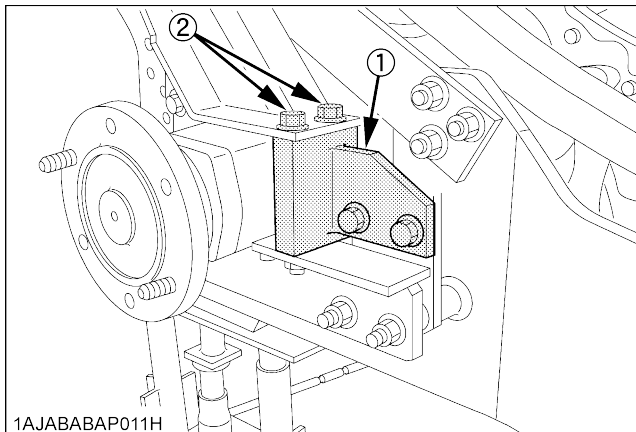

- (1) Rear bracket  
 (2) 2 - M14 x 148 bolts [Original bolts]  
 2 - M14 spring lock washers  
 Tightening torque: 167-196 N-m  
 (17.0-20.0 kgf-m, 123-144 ft-lbs)

3. Tighten a bolt only one of the front of a sub frame and lift the back end of the sub frame using a hoist.

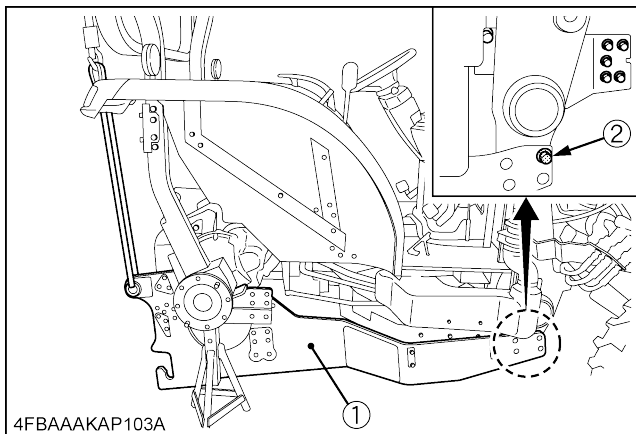

- (1) Sub frame  
 (2) 1 - M16 x 55 bolt  
 1 - 5/8 hardened plain washer  
 1 - M16 spring lock washer  
 1 - M16 nut

**IMPORTANT :**

- Be sure to apply a nylon strap to the back end of the sub frame for hoisting it.
- If the rear of the sub frame is raised too much with a crane, it will hit the fuel tank. Take much care not to hit it when raising the rear of the sub frame.

4. Temporarily tighten the bolts and nuts in place.

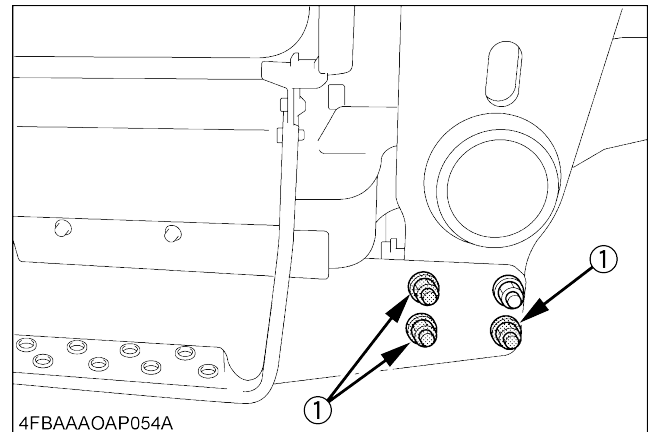

- (1) 3 - M16 x 55 bolts  
 3 - 5/8 hardened plain washers  
 3 - M16 spring lock washers  
 3 - M16 nuts  
 Tightening torque: 196-225 N-m  
 (20.0-23.0 kgf-m, 145-166 ft-lbs)

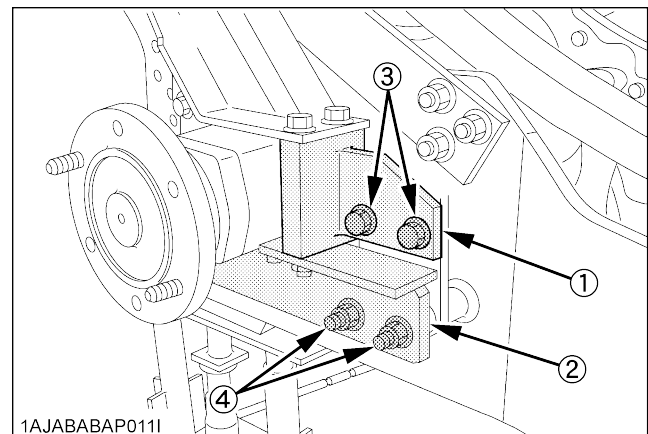

- (1) Rear bracket  
 (2) Frame  
 (3) 4 - M16 x 50 bolts  
 4 - 5/8 hardened plain washers  
 4 - M16 spring lock washers  
 4 - M16 nuts  
 (4) 2 - M16 x 140 bolts  
 2 - 5/8 hardened plain washers  
 2 - M16 spring lock washers  
 2 - M16 nuts  
 Tightening torque: 196-225 N-m  
 (20.0-23.0 kgf-m, 145-166 ft-lbs)

**IMPORTANT :**

- If the number of bolts and that of hardened plain washers are the same, additionally put the hardened plain washers at the nut.

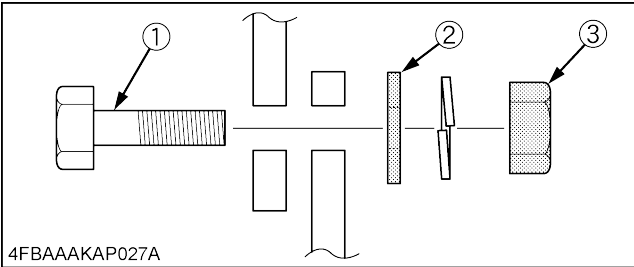

- (1) Bolt  
 (2) Hardened plain washer  
 (3) Nut

5. Attach the female coupler and plug to joint coupler.

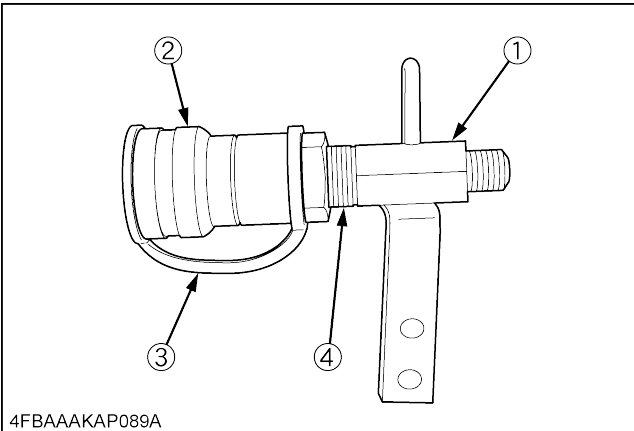

4FBAAAKAP089A

- (1) Joint coupler  
 Thread size: 1/2 - 14 NPT  
 Tightening torque: 49 to 58 N-m  
 (5.0 to 5.9 kgf-m, 36 to 43 ft-lbs)
- (2) Female coupler  
 (3) Plug  
 (4) Sealing tape

**NOTE :**

- Wrap tapered thread of the joint coupler with sealing tape before assembling.
- When wrapping the sealing tape, leave 1st and 2nd threads free and wrap 2 to 3 times clockwise pulling tightly.

6. Attach the frame support, connecting plate and joint stay.  
 Attach the joint coupler to joint stay.

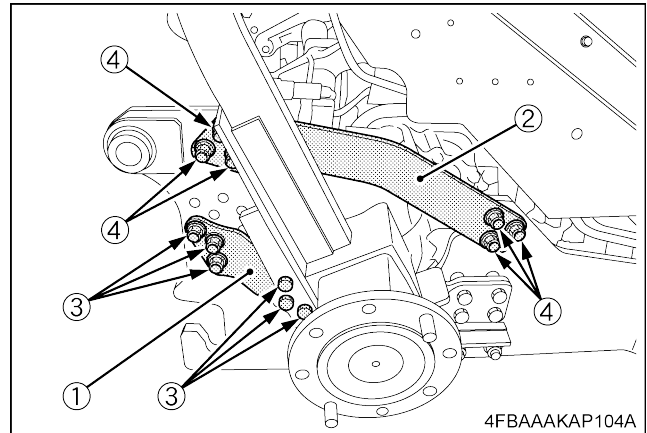

4FBAAAKAP104A

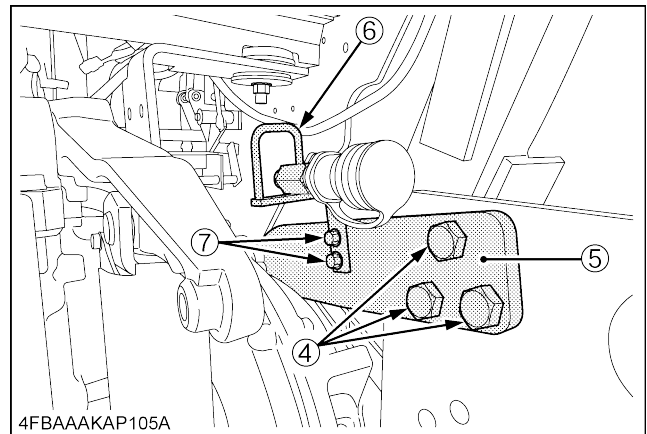

4FBAAAKAP105A

- (1) Frame support  
 (2) Connecting plate  
 (3) 6 - M16 x 50 bolts  
 6 - 5/8 hardened plain washers  
 6 - M16 spring lock washers  
 6 - M16 nuts  
 (4) 12 - M16 x 50 bolts  
 12 - 5/8 hardened plain washers  
 12 - M16 spring lock washers  
 12 - M16 nuts  
 (5) Connecting plate [RH only]  
 Tightening torque: 196 to 225 N-m  
 (20.0 to 23.0 kgf-m, 145 to 166 ft-lbs)  
 (6) Joint coupler  
 (7) 2 - M8 X 20 bolts

**IMPORTANT :**

- Do not tighten fasteners until all components are assembled.
- Finally tighten the fasteners to the specified torque.

## Hydraulic Line

- Remove each bolt and raise the operating seat. And then lock the seat.

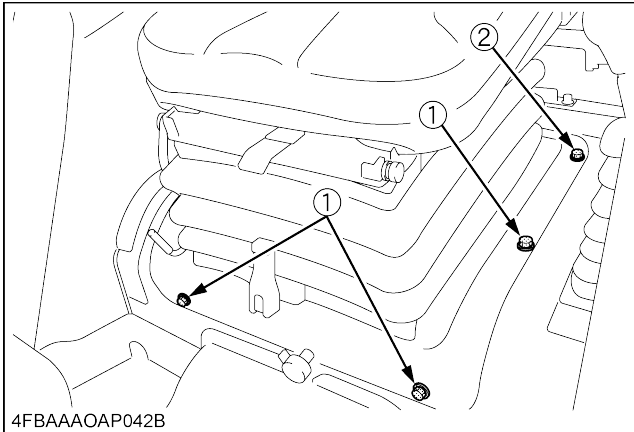

4FBAAAOP042B

- 4 - M8 bolts
- 2 - M8 nuts

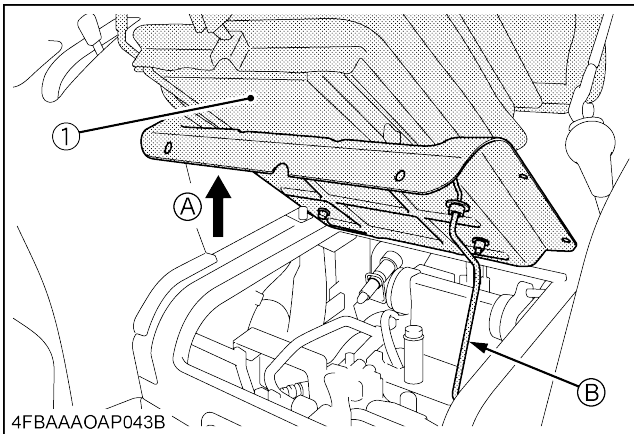

4FBAAAOP043B

- Operating seat
- (A) Raise
- (B) Lock the seat

- Remove the bolt and tube.

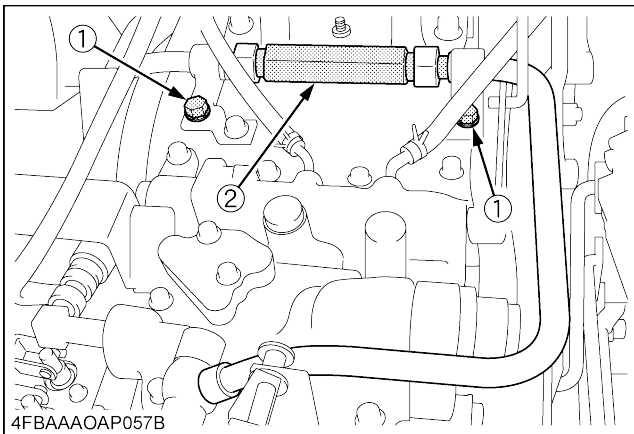

4FBAAAOP057B

- 2 - M8 bolts
- Tube

- Wind the sealing tape around the backhoe outlet hose. Attach sleeve by band cord, male coupler and cap to the outlet hose.

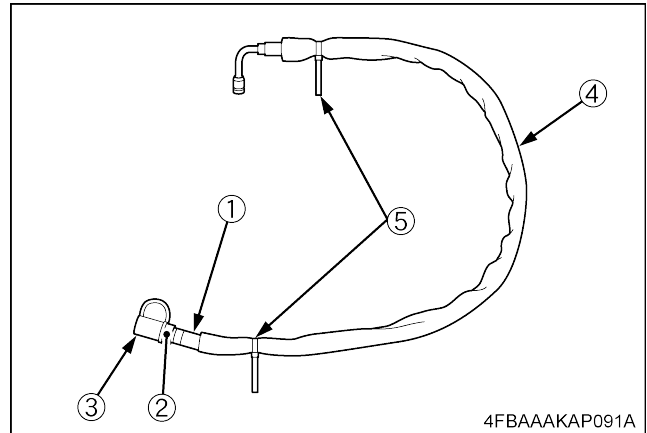

4FBAAAOP091A

- Backhoe outlet hose
- Male coupler  
Thread size: 1/2 - 14 NPT  
Tightening torque: 49 to 58 N-m  
(5.0 to 5.9 kgf-m, 36 to 43 ft-lbs)
- Cap
- Sleeve
- Band cord

- Connect the joints as shown below and connect the backhoe inlet hose and backhoe outlet hose. Then tighten the bolts using torque.

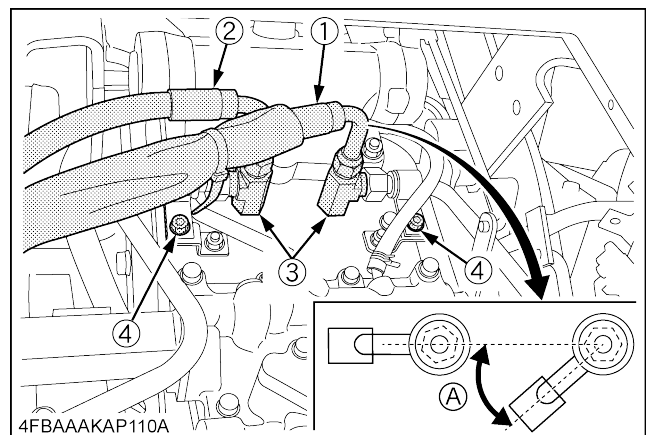

4FBAAAOP110A

- Backhoe outlet hose
- Backhoe inlet hose  
Thread size: 3/4 - 16 UNF  
Tightening torque: 36 to 40 N-m  
(3.7 to 4.1 kgf-m, 27 to 30 ft-lbs)
- Joint  
Tightening torque: 36 to 108 N-m  
(9.2 to 11.0 kgf-m, 67 to 79 ft-lbs)
- 2-M8 bolts

(A) 10°

5. Connect the backhoe inlet hose to the coupler joint.

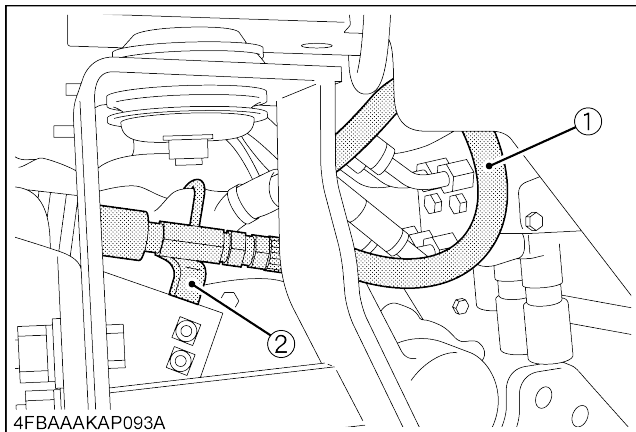

- (1) Backhoe inlet hose  
Thread size: 3/4 - 16 UNF  
Tightening torque: 36 to 40 N-m  
(3.7 to 4.1 kgf-m, 27 to 30 ft-lbs)

- (2) Coupler joint

6. Lower the operating seat and tighten each bolt.  
7. Connect the male coupler to the female coupler.  
Pass the outlet hose through the coupler joint.

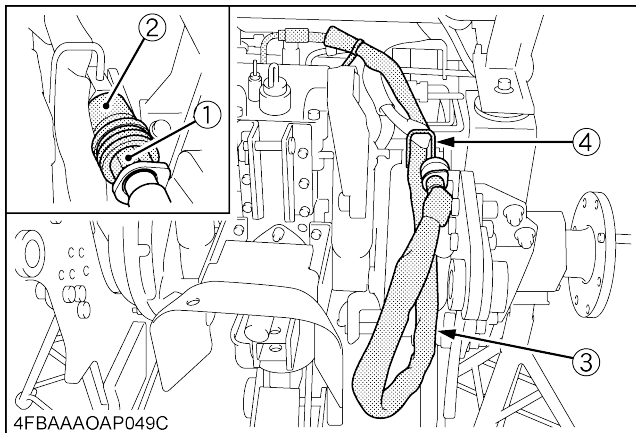

- (1) Male coupler  
(2) Female coupler  
(3) Outlet hose  
(4) Coupler joint

8.  Attach the operating seat to the floor seat cover. Tighten the bolts and nuts by the correct tightening torque.

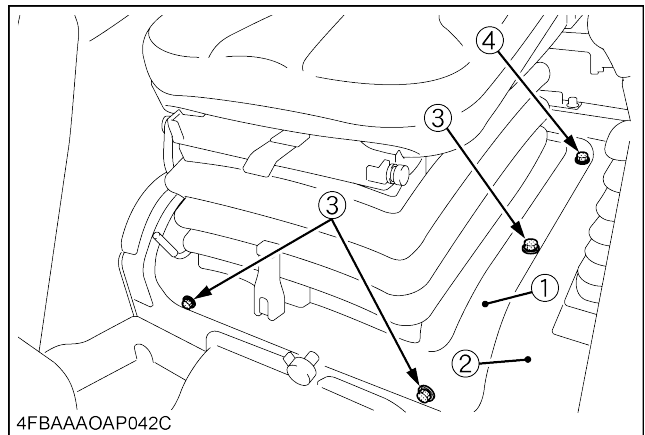

- (1) Operating seat  
(2) Floor seat cover  
(3) 4-M8 bolts  
(4) 2-M8 nuts

Tightening torque: 23.6 to 27.4 N-m  
(2.4 to 2.8 kgf-m, 17.4 to 20.2 ft-lbs)

#### ◆ Rear Wheels

1.  Install the right and left rear wheels to the tractor with the bolts and nuts. Tighten the bolts and nuts by the correct tightening torque.

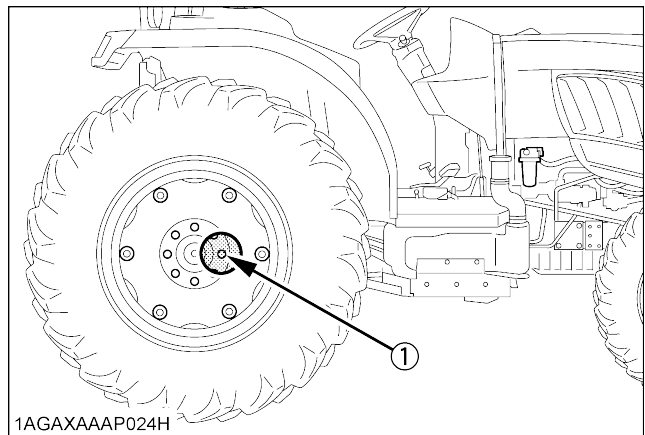

(1) Tightening torque: 215 N-m (22 kgf-m, 160 ft-lbs)

◆ **Loader option**

(When the machine is equipped with the 3rd function or the hydraulic 2 lever quick coupler)

1. Disconnect the loader option's hoses.

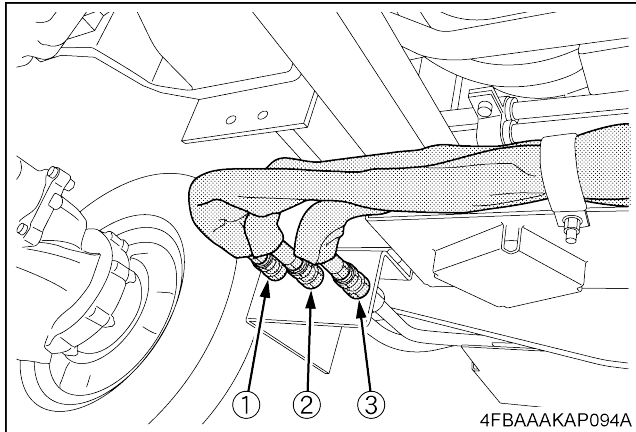

- (1) Hose (P.B)
- (2) Hose (OUT)
- (3) Hose (IN)

2. Remove the sub frame bolts first and then the optional valve cover.

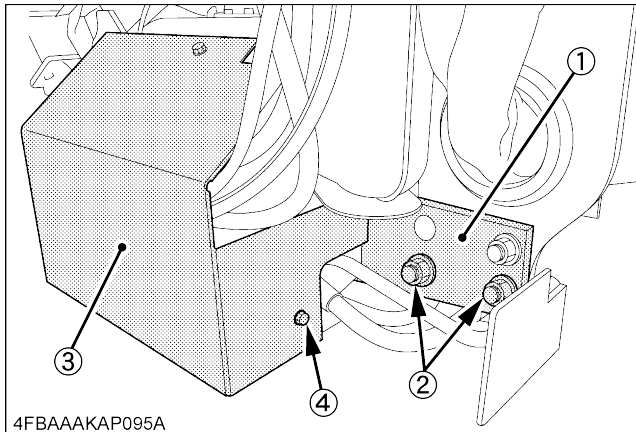

- (1) Sub frame
- (2) 2 - M16 nuts
- (3) Valve cover
- (4) 3 - M8 bolts

3. Disconnect the coupler, the relay and the band cord.

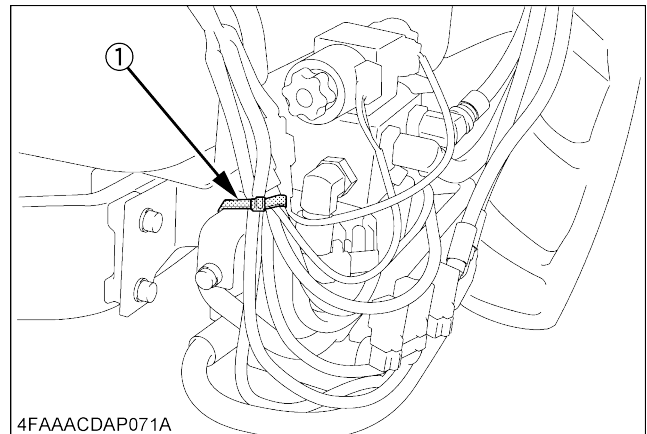

**[3rd function]**

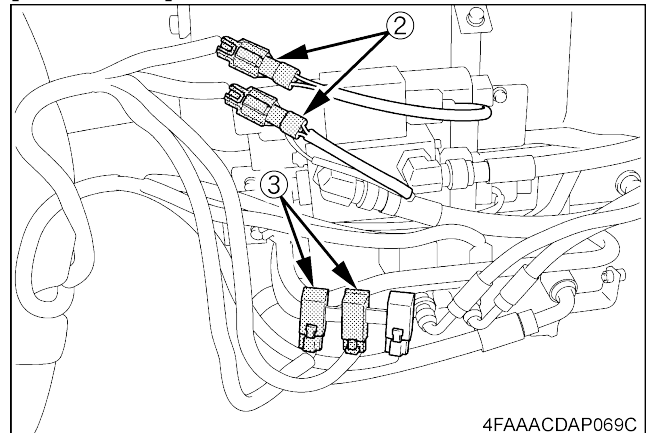

**[Hydraulic 2 lever quick coupler]**

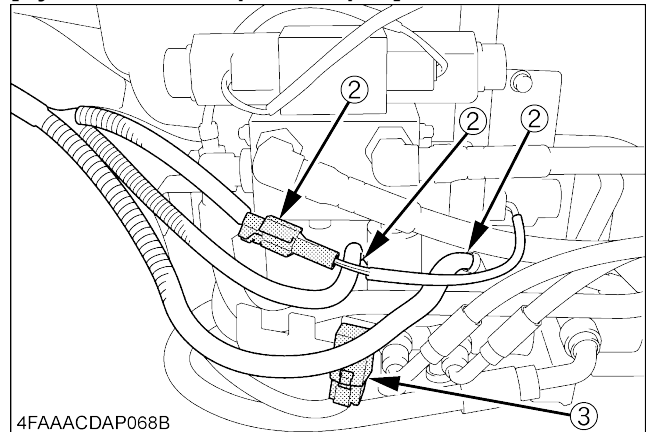

- (1) Band cord
- (2) Coupler
- (3) Relay

4. Disconnect the 3rd function hose and the hydraulic 2 lever quick coupler hose.  
Remove the bolts and take the valve out of the sub frame.

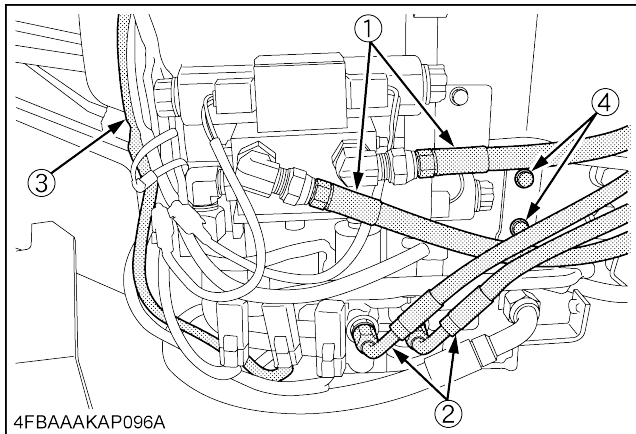

- (1) 3rd function hose  
(2) HYD. 2 lever quick coupler hose  
(3) Wire harness  
(4) 4 - M10 bolts

5. Dismount the loader sub frame.  
6. Mount the backhoe sub frame instead.  
(For details, refer to "Sub Frame" in "ASSEMBLY [BH4985]" section.)  
7. Disconnect the inlet hose.

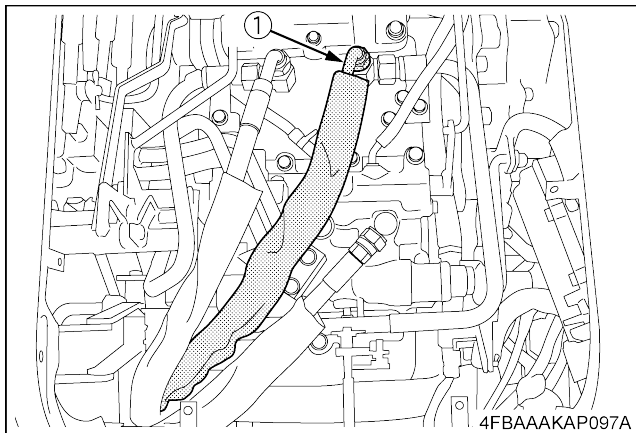

- (1) Inlet hose

8. Reconnect the inlet hose to the coupler joint.  
Pass the backhoe outlet hose through the coupler joint and connect this hose, as shown below.

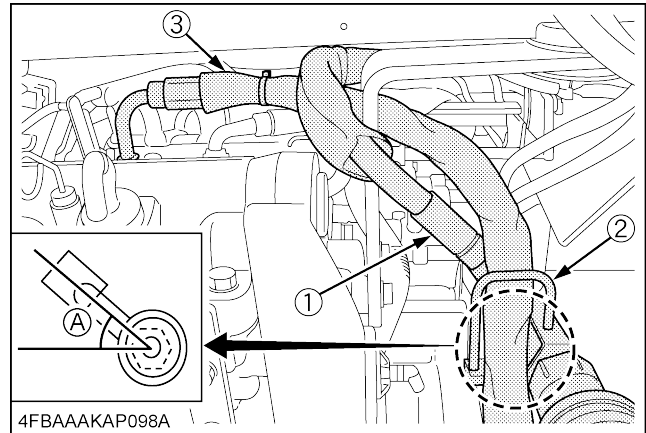

- (1) Inlet hose  
(2) Coupler joint  
(3) Backhoe outlet hose  
(A) 35°  
Thread size: 3/4 - 16 UNF  
Tightening torque: 36 to 40 N-m  
(3.7 to 4.1 kgf-m, 27 to 30 ft-lbs)

9. Reattach the related parts in the reverse order of dismantling the loader option.  
(For details, refer to LA555, LA805, LA1055 ASSEMBLY INSTRUCTIONS)

## ■ Tool Box

1. Detach the tool box from the tool box stay.

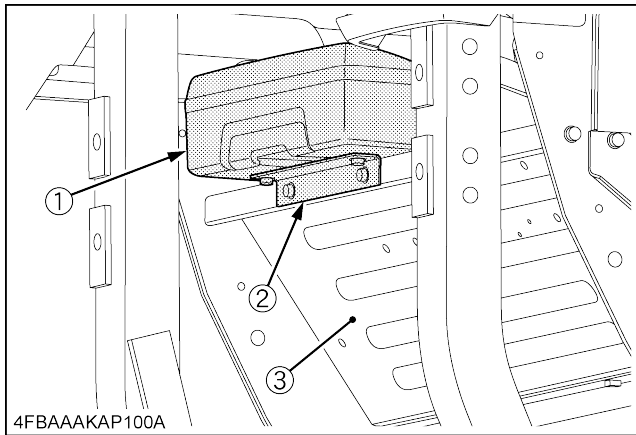

- (1) Tool box
- (2) Tool box stay
- (3) Floor seat

### NOTE :

- After detaching the tool box, secure its stay back in position in order not to lose it.

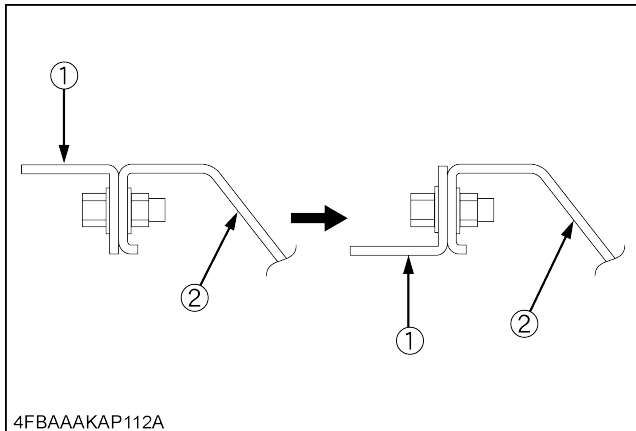

- (1) Tool box stay
- (2) Floor seat

2. Attach the tool box and the tool box stay to the left side of the tractor ROPS.

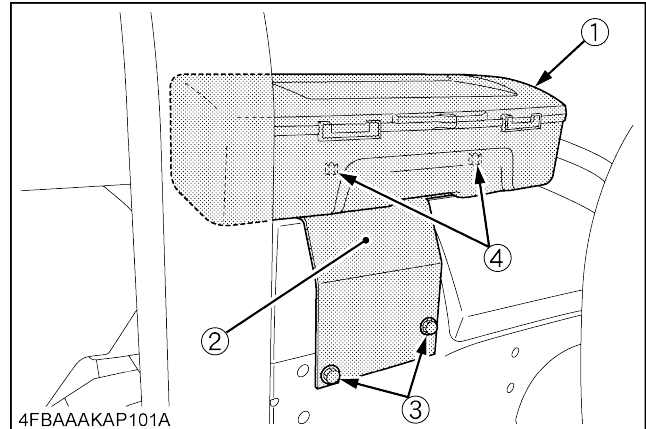

- (1) Tool box
- (2) Tool box stay
- (3) 2 - M8 x 16 bolts  
2 - M8 Flange nuts
- (4) 2 - M8 x 25 bolts

## ■ Installing the Lift Rod Bracket

When using the 3P-link, attach the lift rod brackets to the lower links in the following figure.

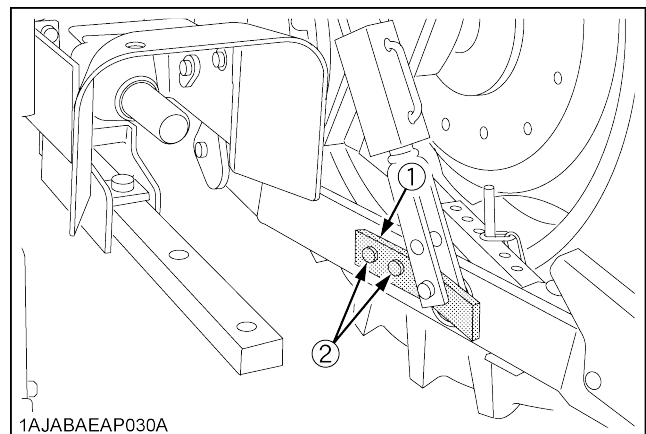

- (1) 2 - lift rod bracket
- (2) 4 - M16 x 75 bolts  
4 - M16 spring lock washers  
4 - M16 nuts



## ASSEMBLY [BH4996 BH4986]

1. Detach the rear tire (RH), fender (RH) and operating seat from the tractor.

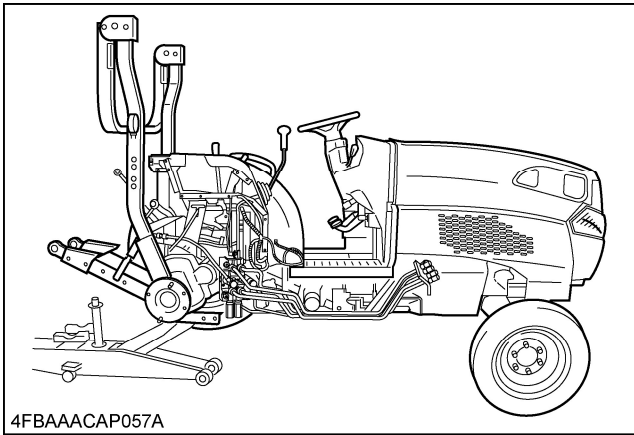

### NOTE :

- Before detaching the operating seat, disconnect the OPC wire harness.

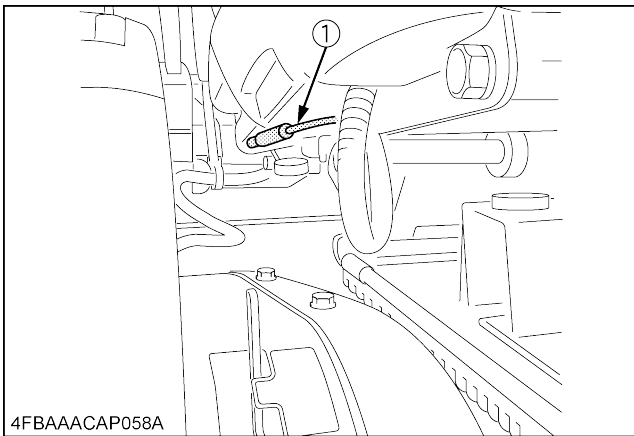

(1) OPC wire harness

## Layout of BH77 Backhoe Hydraulic Line

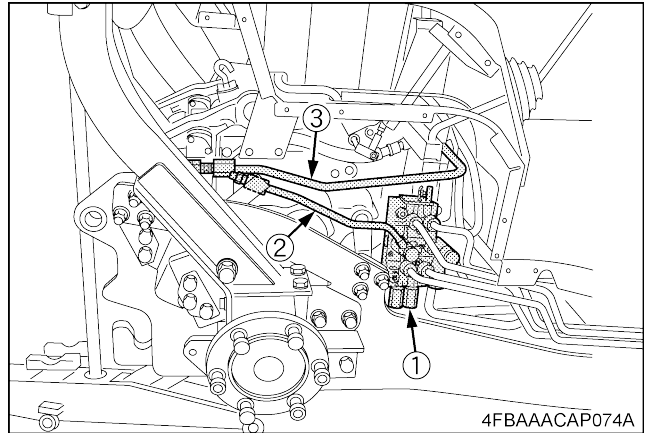

- (1) Front loader valve
- (2) Backhoe inlet tube
- (3) Backhoe outlet tube

## ■ Hydraulic Line

1. Disconnect the front loader power beyond tube.

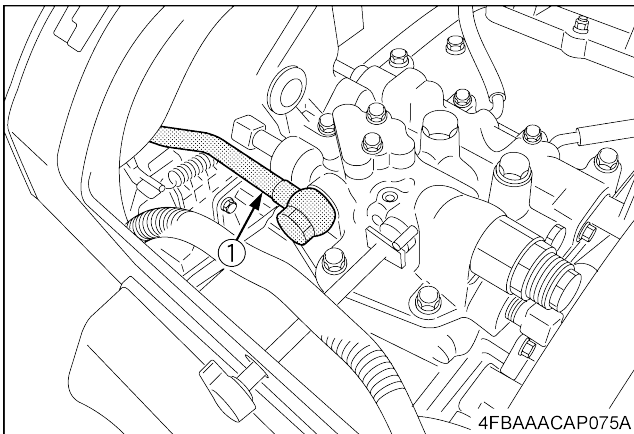
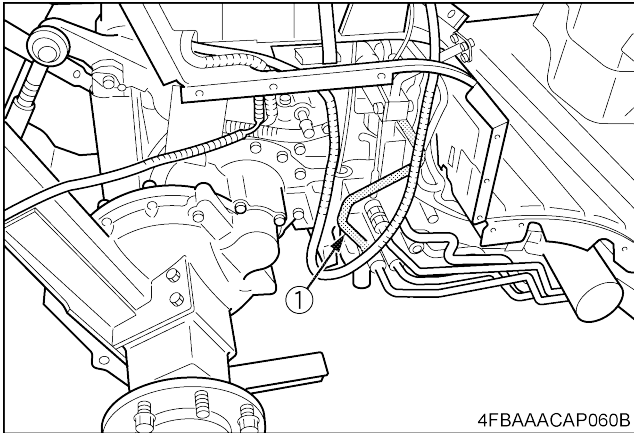

(1) Front loader power beyond tube

2. Connect the backhoe inlet tube to the power beyond port of the loader valve.

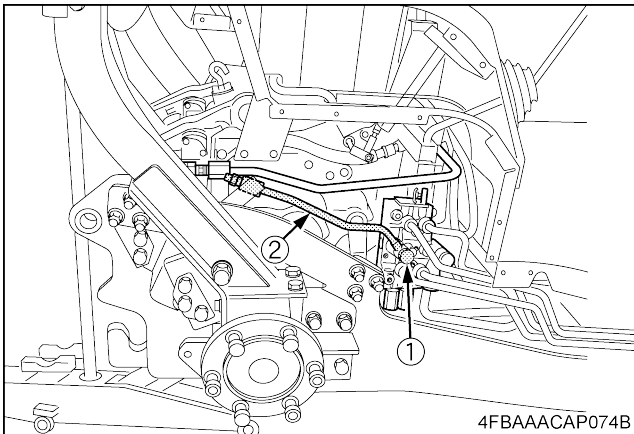

(1) Power beyond port  
(2) Backhoe inlet tube

3. Connect the backhoe outlet hose to the power beyond port (C) of the hydraulic block.

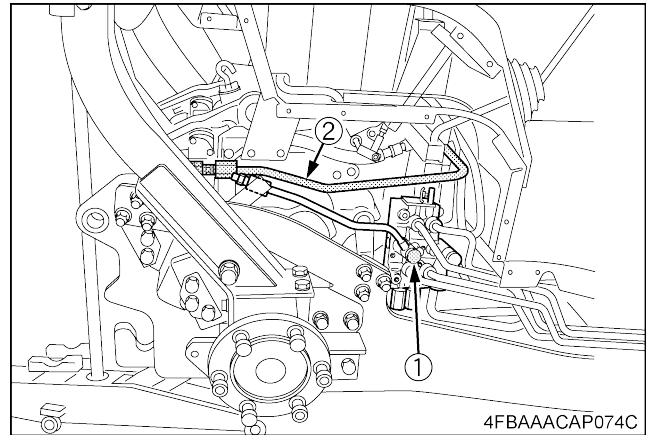

(1) Power beyond port (C)  
(2) Backhoe outlet tube

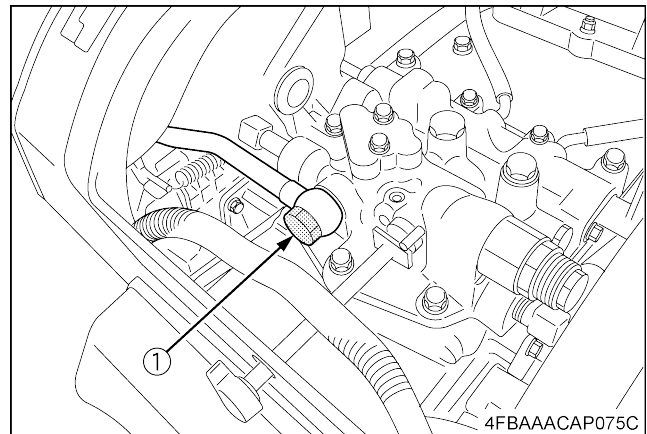

### IMPORTANT :

- Make sure quick coupler with red cap is connected securely.

4.  Attach the operating seat to the floor seat cover. Tighten the bolts and nuts by the correct tightening torque.

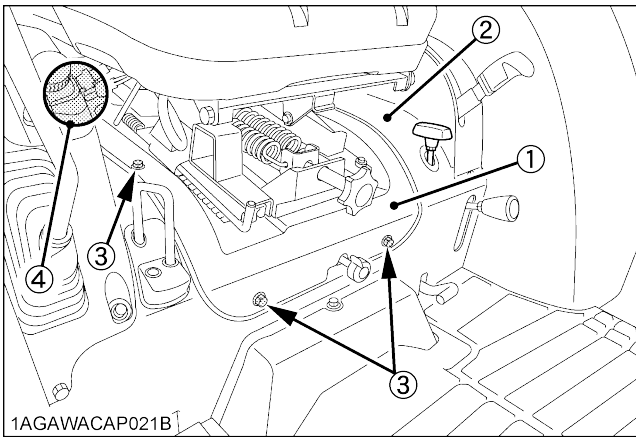

- (1) Operating seat
- (2) Floor seat cover
- (3) 4-M8 bolts
- (4) 2-M8 nuts

Tightening torque: 23.6 to 27.4 N-m  
(2.4 to 2.8 kgf-m, 17.4 to 20.2 ft-lbs)

## ■ Sub Frame

1. Detach the front loader sub frames.

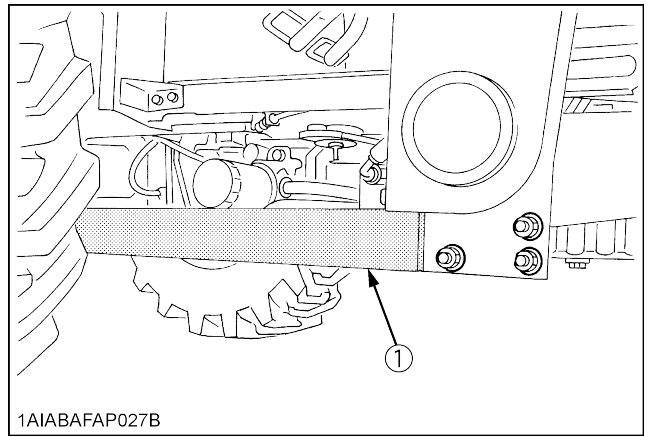

- (1) Sub frame

2. On the L3240(-3) and L3540(-3), remove the collar first and then attach the rear bracket.

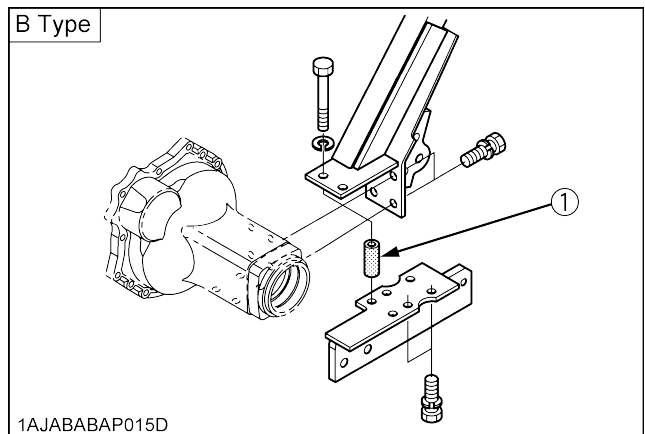
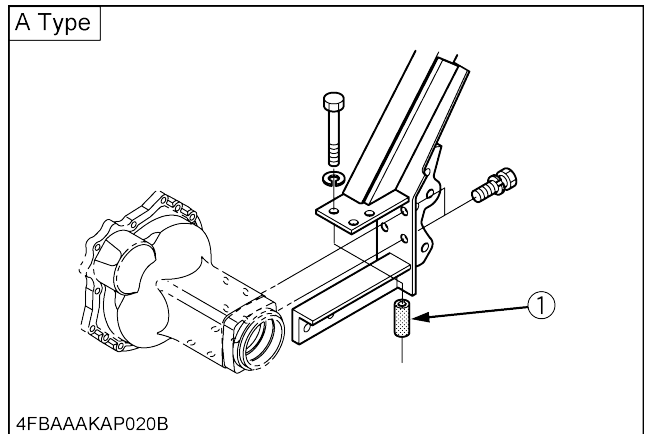

- (1) Collar

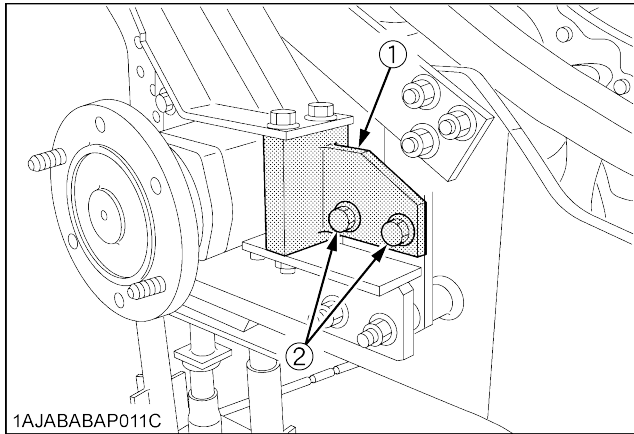

(1) Rear bracket

- (2) 2 - M16 x 55 bolts [L3240(-3), L3540(-3)]  
 4 - 5/8 hardened plain washers  
 2 - M16 spring lock washers  
 2 - M16 nuts

Tightening torque: 196 to 225 N-m  
 (20.0 to 23.0 kgf-m, 145 to 166 ft-lbs)

**IMPORTANT :**

- Do not tighten fasteners until all components are assembled.
- Finally tighten the fasteners to the specified torque.

3. Lift the back end of the sub frame using a hoist and jack up the front of the sub frame. Temporarily tighten the bolts and nuts in place.

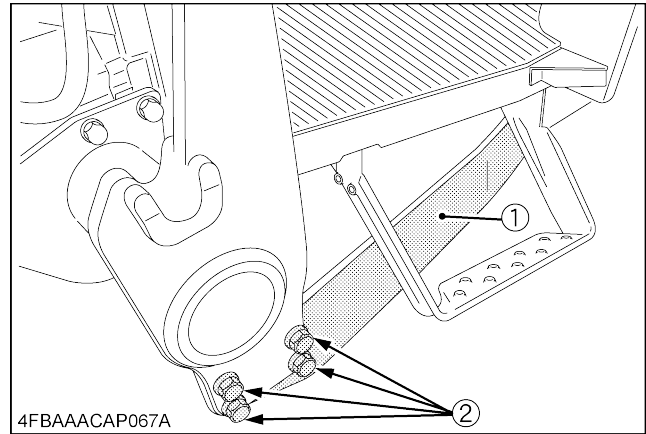

(1) Sub frame

- (2) 4 - M16 x 55 bolts  
 8 - 5/8 hardened plain washers  
 4 - M16 spring lock washers  
 4 - M16 nuts

Tightening torque: 196 to 225 N-m  
 (20.0 to 23.0 kgf-m, 145 to 166 ft-lbs)

**IMPORTANT :**

- Be sure to apply a nylon strap to the back end of the sub frame for hoisting it.
- Do not tighten fasteners until all components are assembled.
- Finally tighten the fasteners to the specified torque.

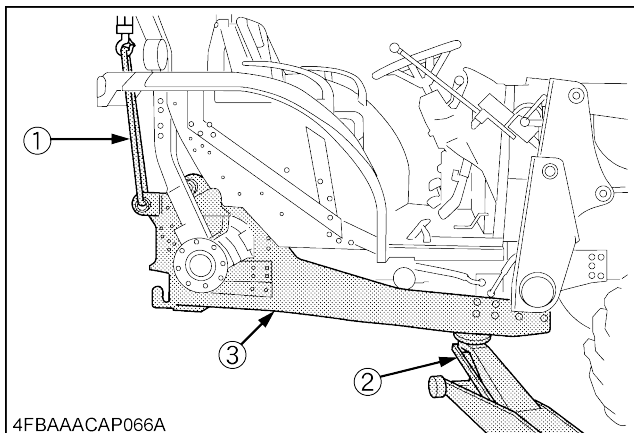

- (1) Nylon strap  
 (2) Jack  
 (3) Sub frame

4. Using the bolts and nuts, temporarily fix the following components to the sub frame: ROPS frame, rear bracket, frame support and connecting plate.

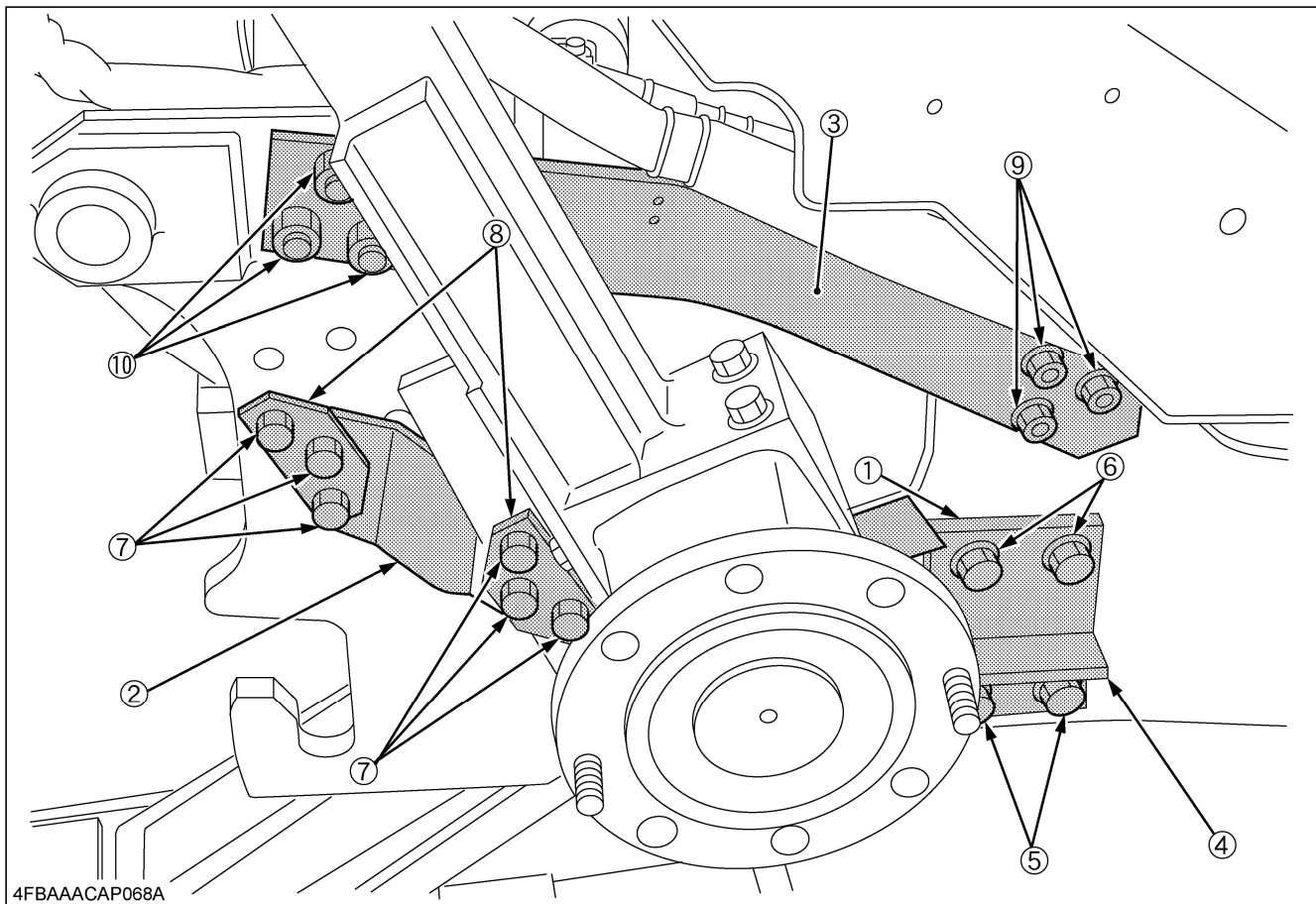

4FBAAACAP068A

- (1) Rear bracket  
 (2) Frame support  
 (3) Connecting plate  
 (4) ROPS Frame  
 (5) 2 - M16 x 135 bolts  
 4 - 5/8 hardened plain washers  
 2 - M16 spring lock washers  
 2 - M16 nuts  
 (6) 2 - M16 x 55 bolts  
 4 - 5/8 hardened plain washers  
 2 - M16 spring lock washers  
 2 - M16 nuts  
 (7) 6 - M16 x 55 bolts  
 6 - M16 spring lock washers  
 6 - M16 nuts  
 (8) 4 - Locking washers  
 (9) 3 - M16 x 55 bolts  
 6 - 5/8 hardened plain washers  
 3 - M16 spring lock washers  
 3 - M16 nuts  
 (10) 3 - M16 x 110 bolts  
 3 - M16 spring lock washers  
 3 - M16 nuts

Tightening torque: 196 to 225 N-m  
 (20.0 to 23.0 kgf-m, 145 to 166 ft-lbs)

**IMPORTANT :**

- When mounting part (8) be sure to have correct position of (X) and (Y).
- If mounting in the wrong direction you may damage threads of bolt.

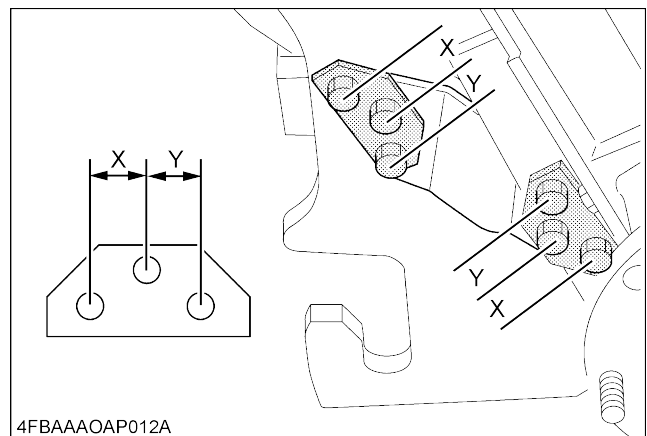

4FBAAAOAP012A

(X)=36.5 mm (1.4 in.)  
 (Y)=39.0 mm (1.5 in.)

5. Connect the male coupler to the inlet hose. Connect the coupler joint and female coupler to the inlet pipe. Fix the coupler joint to the connecting plate (RH). Connect the male coupler to the female coupler.

**NOTE :**

- Take this step after mounting the connection plate (RH) in position.

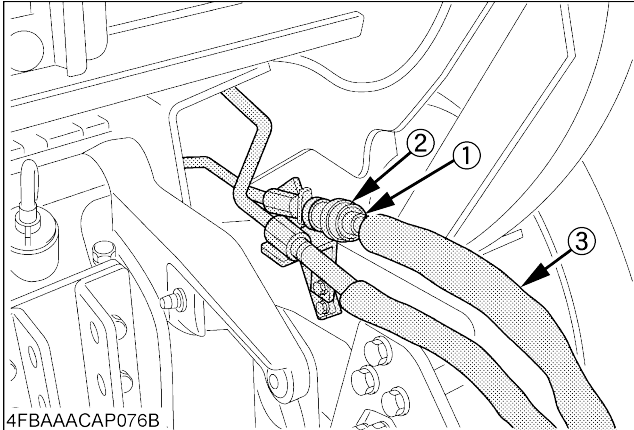

- (1) Male coupler
- (2) Female coupler
- (3) Inlet hose
- (4) Stay

6. After assembling, connect the OPC wire harness.

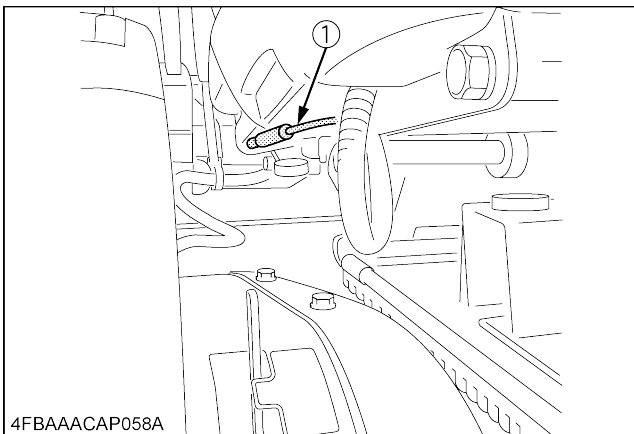

- (1) OPC wire harness

**■ Rear Wheels**

1.  Install the right and left rear wheels to the tractor with the bolts and nuts. Tighten the bolts and nuts by the correct tightening torque.

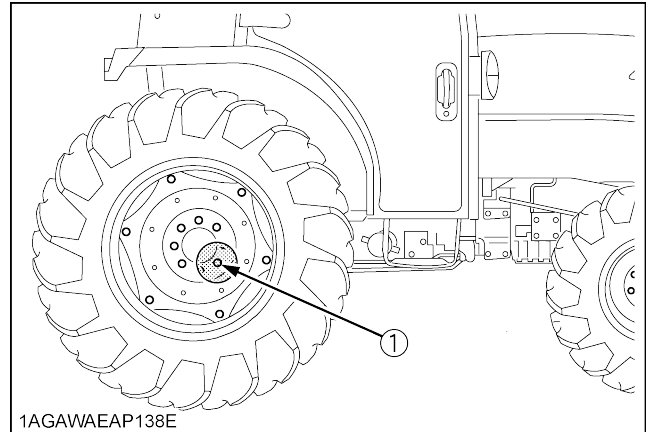

- (1) Tightening torque: 215 N-m (22 kgf-m, 160 ft-lbs)

## ■ Installing the Stay for ROPS Connecting Bar [BH4996 only]

1. Detach the bar.

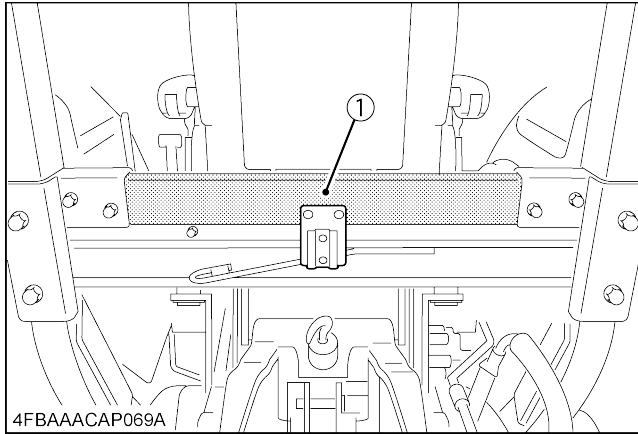

(1) Bar

2. Attach the stay (LH, RH).

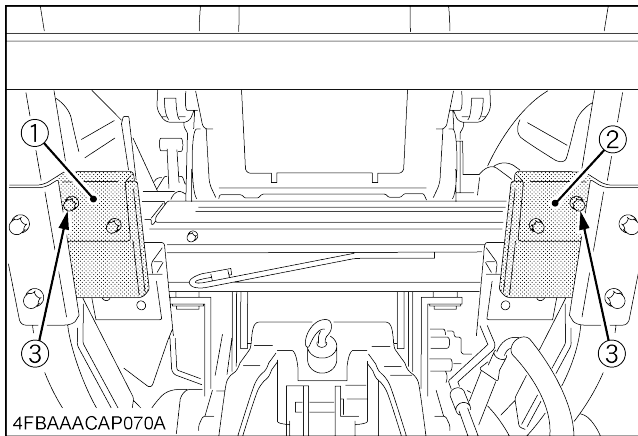

(1) Stay (LH)                      (3) 4 - M12 x 65 sems bolts  
(2) Stay (RH)                      (Re-use)

3. Reinstall the bar.

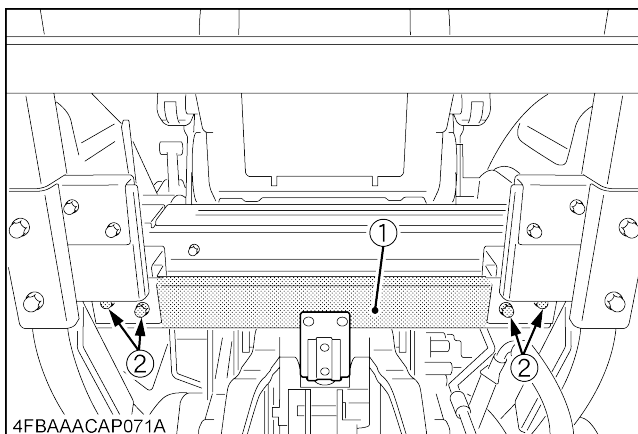

(1) Bar                                      (2) 4 - M12 x 65 sems bolts

## ■ Reinstalling the Top Link Holder [BH4996 only]

1. Remove the top link holder.
2. Fit the collar on the removed top link holder. Set them together back into position.

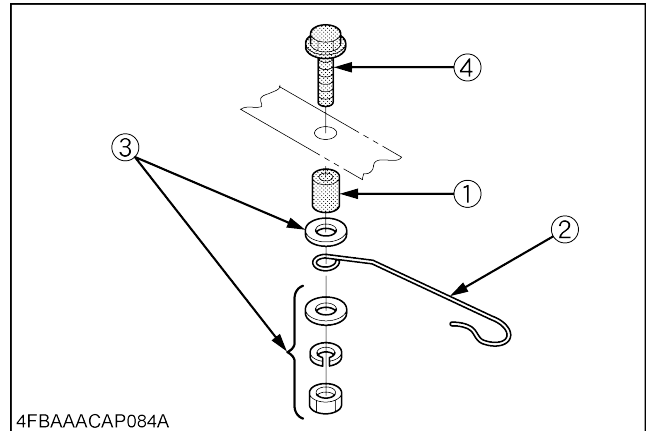

(1) Collar  
(2) Top link holder  
(Re-use)  
(3) 2 - plain washers  
1 - spring lock washer  
1 - locking nut  
(Re-use)  
(4) M8 x 45 flange bolt

## ■ Installing the Lift Rod Bracket

When using the 3P-link, attach the lift rod brackets to the lower links in the following figure.

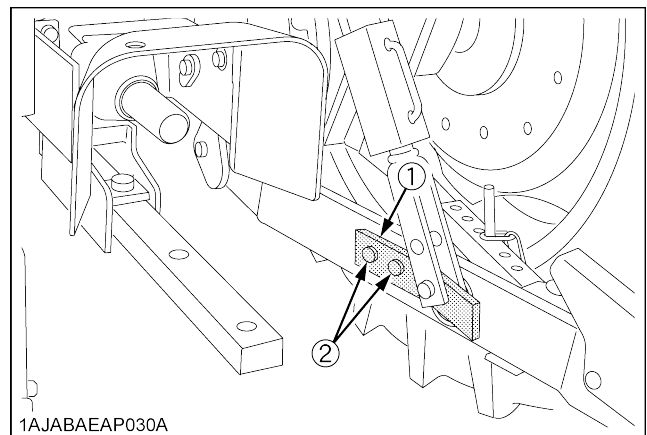

(1) 2 - lift rod bracket  
(2) 4 - M16 x 75 bolts  
4 - M16 spring lock washers  
4 - M16 nuts

## SETTING UP THE BACK-HOE

### ■ Dipperstick

1. Install dipperstick assy to the boom using pins, spacers, bolts, nuts.  
Connect hoses to the each port on the boom.

#### IMPORTANT :

- Check the position and the direction of the hose as shown below.

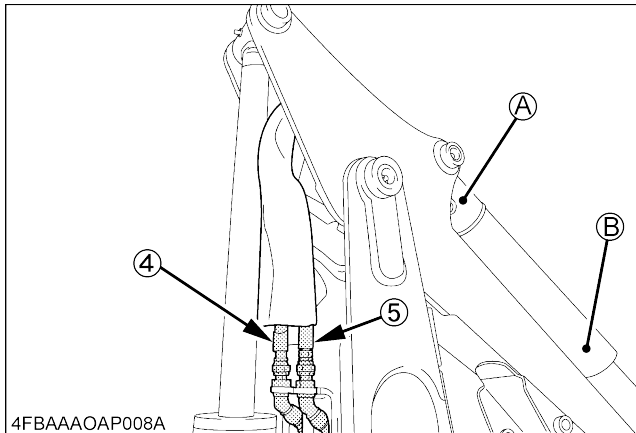
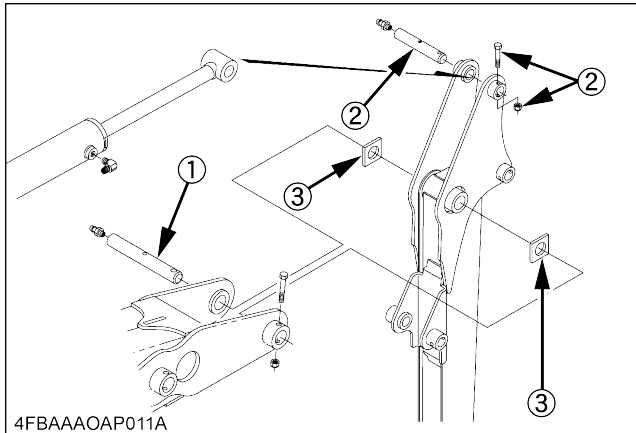

- |                                                                              |                             |
|------------------------------------------------------------------------------|-----------------------------|
| (1) Pin ( $\phi 30 \times 202$ mm),<br>Bolt (M10 x 65), Locking Nut (M10)    | (A) Cylinder<br>bottom side |
| (2) Pin ( $\phi 25 \times 137$ mm),<br>Hex. Bolt (M6 x 50), Locking Nut (M6) | (B) Cylinder<br>rod side    |
| (3) Spacer                                                                   |                             |
| (4) Hose (9/16-18) (Cylinder bottom side)                                    |                             |
| (5) Hose (9/16-18) (Cylinder rod side)                                       |                             |

Tightening torque: 21.7 to 25.8 N-m  
(2.2 to 2.6 kgf-m, 15.9 to 18.8 ft-lbs)

#### NOTE :

- Do not tighten too much a locking nut firmly. The gap between the boss and the locking nut is adjusted in 1 to 3 mm (0.04 to 0.12 in.).
- Tighten up the hose in parallel with the cylinder rod.

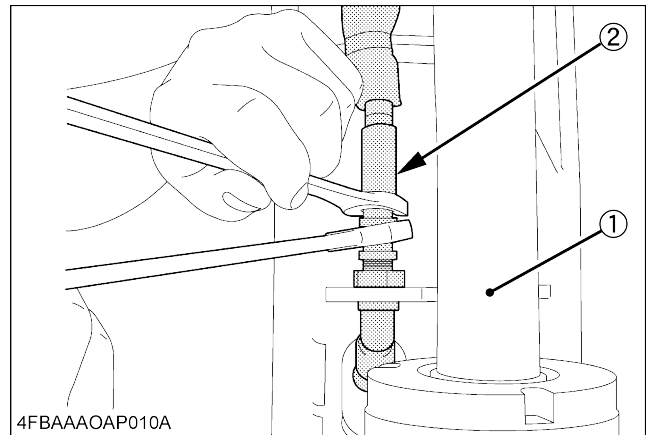
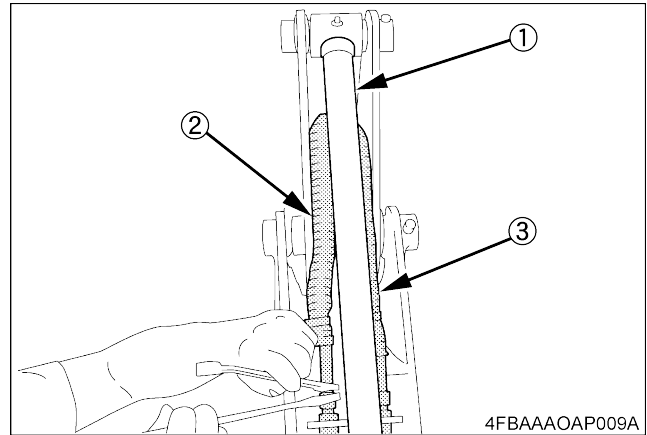

- (1) Cylinder rod  
(2) Hose (Cylinder bottom side)  
(3) Hose (Cylinder rod side)



### ■ Seat [Except BH4962 BH4963 BH4984]

1.  Attach the seat assy and seat support. Tighten the bolts and nuts by the correct tightening torque.

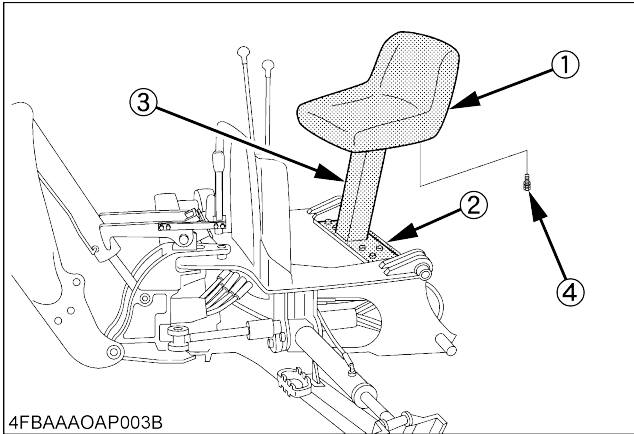

4FBAAAOAP003B

- (1) Seat  
 (2) 6 - M12 x 35 flange bolts  
 6 - M12 nuts  
 Tightening torque: 77.5 to 90.1 N-m  
 (7.9 to 9.2 kgf-m, 57.2 to 66.5 ft-lbs)
- (3) Seat support  
 (4) 4 - 5/16-18 UNC flange bolts  
 Tightening torque: 19.0 to 23.1 N-m  
 (1.9 to 2.4 kgf-m, 14.0 to 17.0 ft-lbs)

2. Secure the outlet hose to the seat assy using the coupler joint.

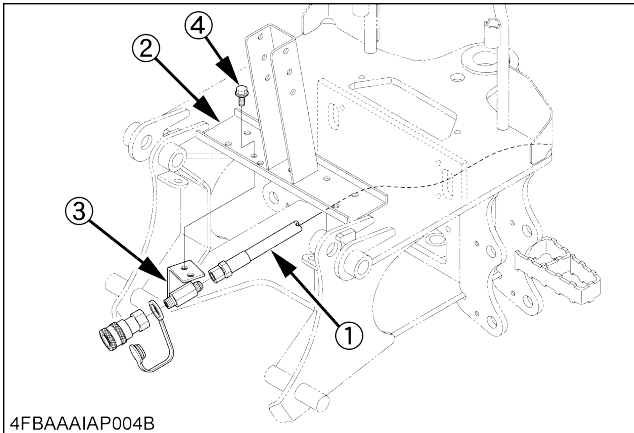

4FBAAAIAP004B

- (1) Outlet hose  
 (2) Seat assy  
 (3) Coupler joint  
 (4) Flange bolt

### ■ Step Plate [BH4962 BH4963 BH4984]

1. Attach the step plate.
2. Secure the outlet hose to the step plate using the coupler joint.

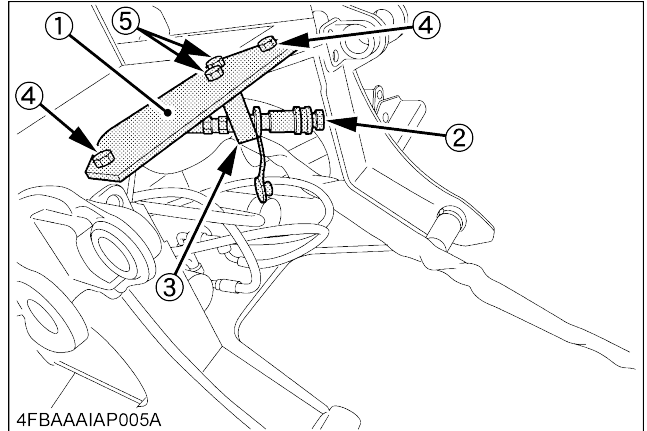

4FBAAAIAP005A

- (1) Step plate  
 (2) Outlet hose  
 (3) Coupler joint  
 (4) 2 - M12 x 35 bolts  
 2 - M12 nuts  
 (5) 2 - M8 flange bolts

### ■ Control Lever [BH4962 BH4963 BH4984]

1. Remove the lever grips and detach the cover plate.
2. Detach the valve cover.

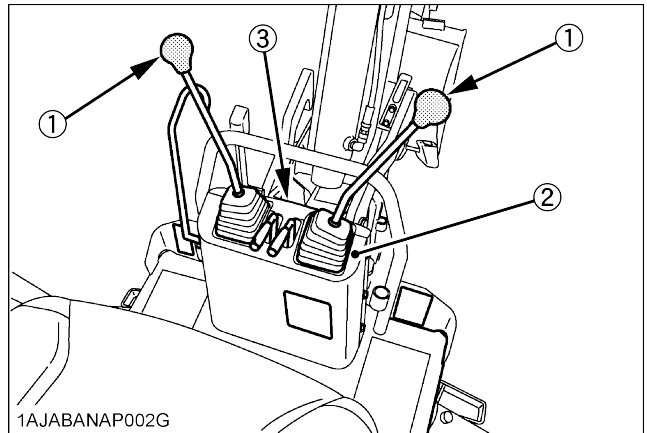

1AJABANAP002G

- (1) Lever grip  
 (2) Cover plate  
 (3) Valve cover

3. Remove the bolts and replace the original control levers (RH and LH) with the accompanying levers.

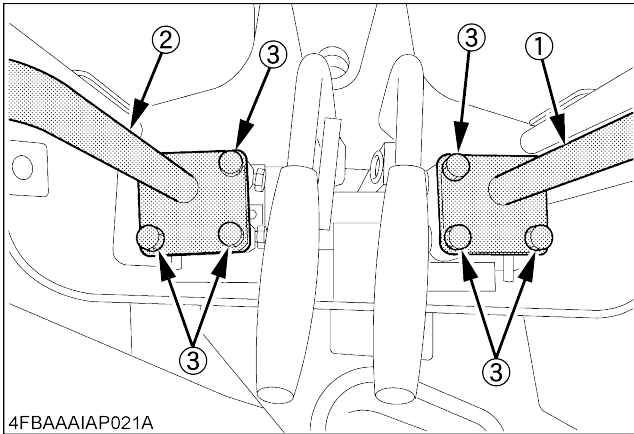

4FBAAAIP021A

(1) Control lever RH

(2) Control lever LH

(3) 6 - M6 x 16 bolts

Tightening torque : 9.8 to 11.2 N-m

(1.0 to 1.1 kgf-m, 7.2 to 8.3 ft-lbs)

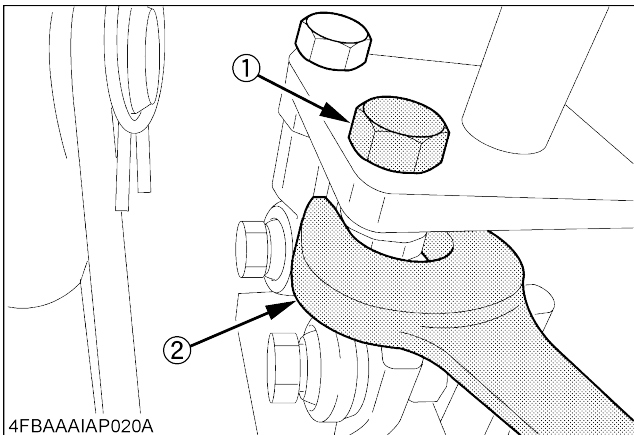

4FBAAAIP020A

(1)

(2)

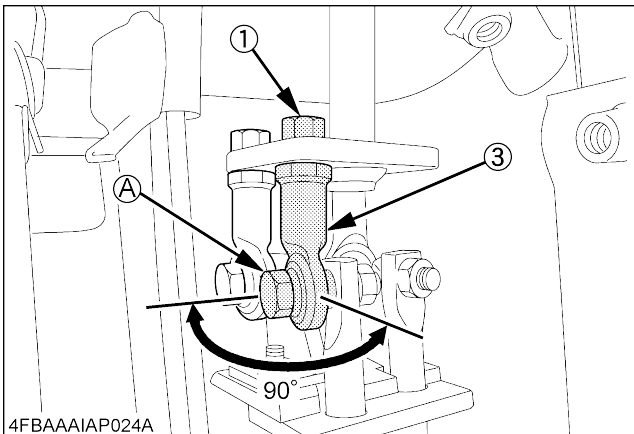

4FBAAAIP024A

(1) M6 x 16 bolt

(2) Wrench

(3) Rod end

**NOTE :**

- When loosening or tightening the bolt, make sure to secure the rod end using a wrench.
- Make sure to attach the rod end at right angles to the bolts (A).

4. Attach the valve cover, cover plate and lever grips back into position.

**■ Bucket**

1. Install bucket to the dipperstick of the backhoe using two pins, bolts and nuts.

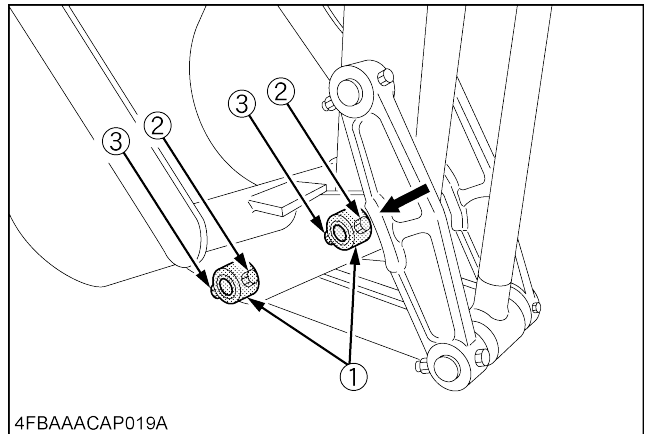

4FBAAACAP019A

(1) Pins (0.98 x 6.17)

(2) Bolt (M10 x 55)

(3) Locking Nut (M10)

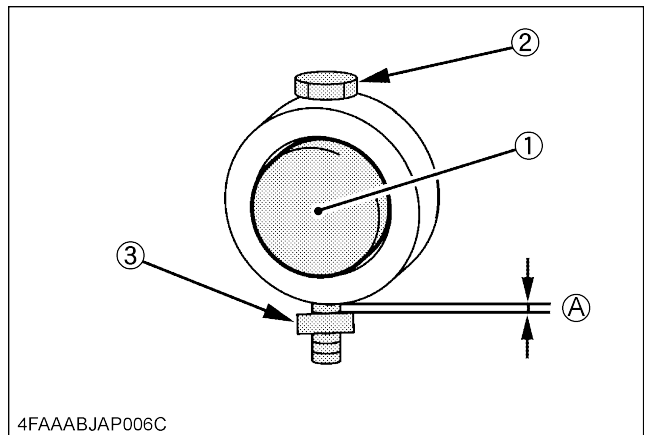

4FAAABJAP006C

(1) Pin

(2) Bolt

(3) Locking nut

(A) 2 to 3 mm (0.08 to 0.12 in.)

**IMPORTANT :**

- Nuts : Do not tighten firmly. Gap between boss and nut should be 2 to 3 mm (0.08 to 0.12 in.).
- Bolts : Make sure not to confuse the set-up direction of bolts.
- Pins : Apply a small amount of multipurpose grease.

## ■ Mech. Thumb BH1976 (Option)

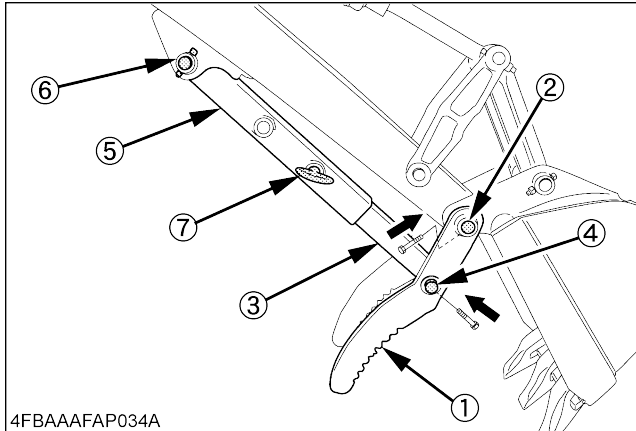

4FBAAAFAP034A

- (1) Thumb weldment
- (2) Pin (25 x 231)  
Grease fitting  
(1/4 - 28T.T. x .68)  
Hex. bolt  
Locking nut
- (3) Adjust link 1
- (4) Pin (25 x 222)  
Hex. bolt  
Locking nut
- (5) Adjust link 2
- (6) Pin (0.98 x 5.90)  
Hex. bolt  
Locking nut
- (7) Set adjust pin

### IMPORTANT :

- Nuts : Do not tighten firmly. Gap between boss and nut should be 2 to 3 mm (0.08 to 0.12 in.).
- Bolts : Make sure not to confuse the set-up direction of bolts.
- Pins : Apply a small amount of multipurpose grease.

## INSTALLING THE BACKHOE



### WARNING

To avoid personal injury or death:

- When starting the engine, always sit in the operator's seat.
- When getting off the tractor, make sure that PTO lever is off and range gear shift lever is in neutral. Set the parking brake.
- Keep hands, feet and body from between tractor and backhoe. Never allow any part of body under the machine.



### CAUTION

To avoid personal injury:

- Make sure the tractor PTO is disengaged.

### IMPORTANT :

- When installing the backhoe, set the engine speed to low idle.
1. Remove the 3-point hitch and / or drawbar. (if equipped)
  2. Make sure the swing lock pin is installed.
  3. Slowly back the tractor / loader, centering to the backhoe main frame.  
Stop the tractor 250 to 300 mm (10 to 12 inches) away from the backhoe.
  4. Shut the engine off and set the parking brake.
  5. Connect the inlet and outlet hoses of the backhoe to the outlet hose and return hose of the tractor.

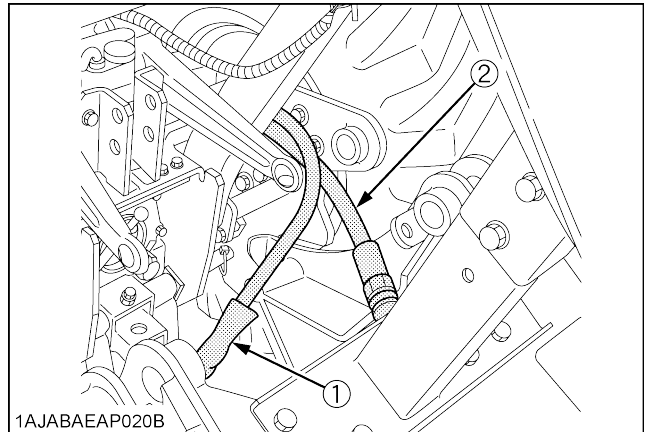

1AJABAEAP020B

- (1) Inlet hose
- (2) Return hose

### IMPORTANT :

- Make sure both hoses are firmly connected before starting the engine.

6. Restart the engine.



## WARNING

To avoid personal injury or death:

- Do not move the joystick control lever to the swing position.

7. Stand beside the rear tire. Move the boom to fully raised position and raise the backhoe by operating the stabilizers until the mount bars on the backhoe main frame are slightly higher than the tractor main frame support hooks.

### NOTE :

- If the support hooks are not parallel to the mount bars, adjust with the stabilizers.

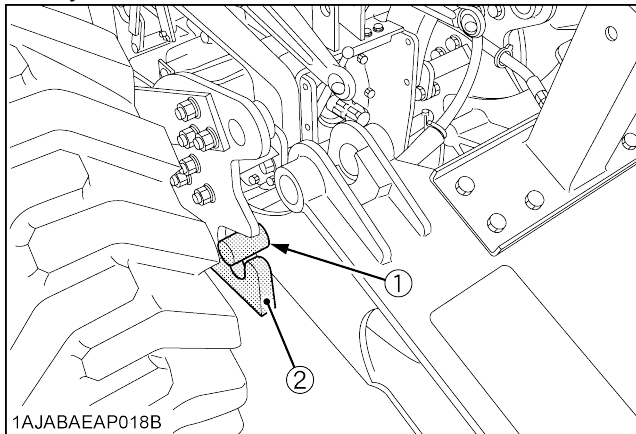

- (1) Mount bar  
(2) Support hook

8. Move the tractor backward until the support hooks on the tractor main frame are just beneath the mount bar on the backhoe main frame.

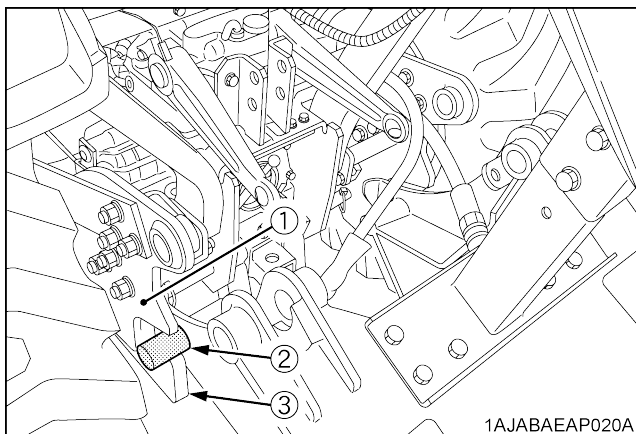

- (1) Guide stop  
(2) Mount bar  
(3) Support hook

9. Lower the mount bar onto the support hooks by operating the stabilizer and boom control levers.
10. Move the boom slowly to the lowering position, and engage the guide plates of the main frame to the bosses of sub frame. Then raise the rear wheels slightly by operating the boom in the lowering direction.
11. Shut off the engine. Reinstall the mounting pins, and insert the slide bar of the mounting pins to the lower hole of the main frame.

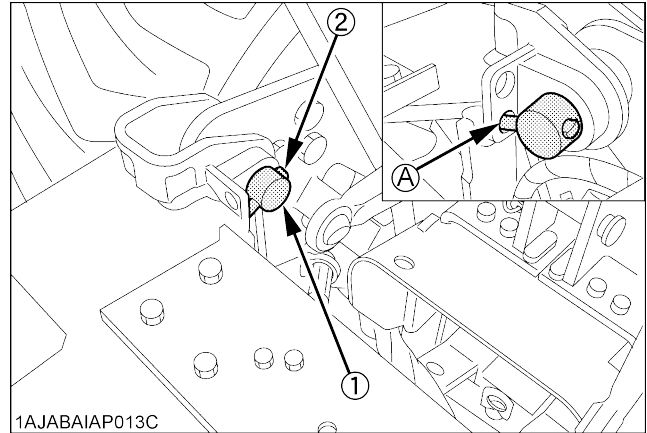

- (1) Mounting pin  
(2) Slide bar  
(A) "Lower hole"

### IMPORTANT :

- If the slide bar of the mounting pins is inserted to the upper hole, the mounting pin comes off and the backhoe might come off. Therefore, please make sure to insert the slide bar to the lower hole.

### NOTE :

- Move the tractor / loader / backhoe to an open area and cycle all backhoe functions. This will check their operation and flow oil back through the system, filtering it and refilling each circuit. Check the hydraulic oil level before putting the backhoe into full operation. See section "MAINTENANCE" for oil type and correct level.

## REMOVING THE BACKHOE

### ■ Removal of The Backhoe



### CAUTION

To avoid personal injury:

- When starting the engine, always sit in the tractor operator's seat.
- When getting off the tractor, make sure that PTO lever is off and range gear shift lever is in neutral. Then set the parking brake.
- Keep hands, feet and body from between tractor and backhoe. Never allow any part of body under the machine.
- When leaving the backhoe operator's seat, fully lower the boom to the ground.
- When removing the backhoe set the swing lock pin.

### IMPORTANT :

- When removing the backhoe, set the engine speed to low idle.
  - For removing the backhoe, locate the tractor / loader / backhoe on a flat level and hard surface, preferably concrete.
- If the surface is soft, place a board on the ground for the bucket and stabilizers.

1. Set the swing lock pin to prevent the pivoting of the boom before removing the backhoe.

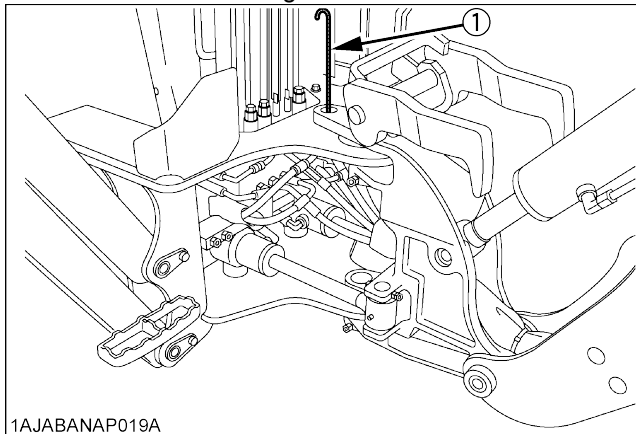

1AJABANAP019A

(1) Swing lock pin

2. Stand beside the rear tire, fully close the dipperstick, curl the bucket and lower the boom until the back of bucket contacts the ground.
3. Keep the stabilizer pads at about 380 mm (15 inches) high.

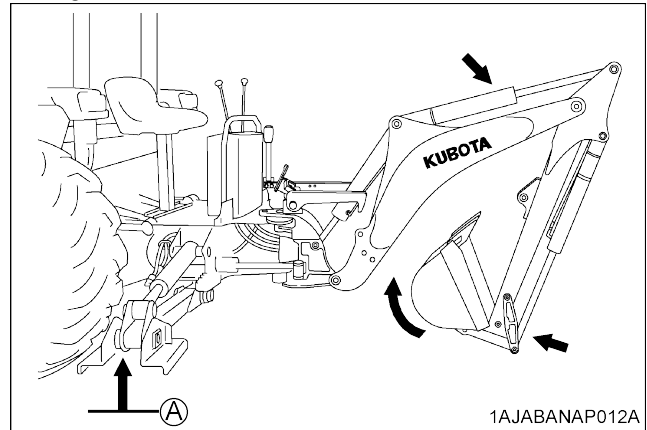

1AJABANAP012A

(A) 380 mm (15 inches)

4. Raise the rear wheels slightly with the boom and remove the mounting pins.

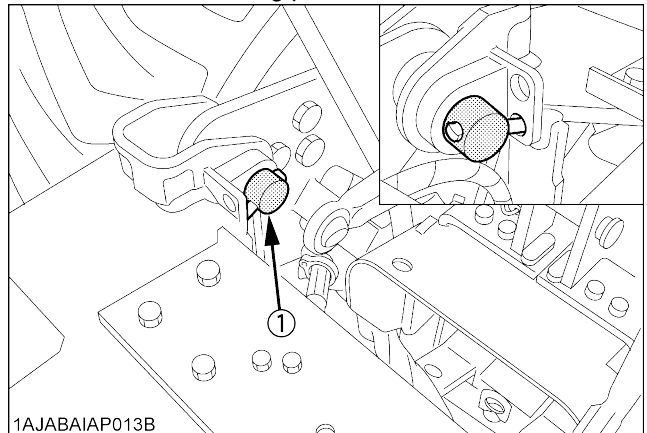

1AJABAIP013B

(1) Mounting pin

5. Slowly raise the boom to disengage the backhoe from the tractor.

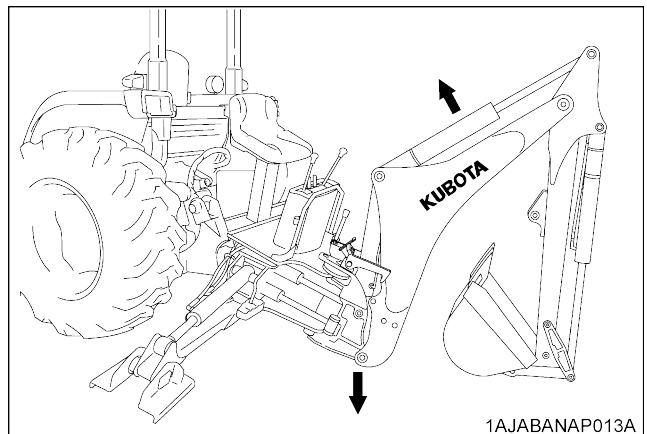

1AJABANAP013A

6. Raise the backhoe by operating the stabilizers in the lowering direction until the mount bars hit the guide stopper on the support hooks.

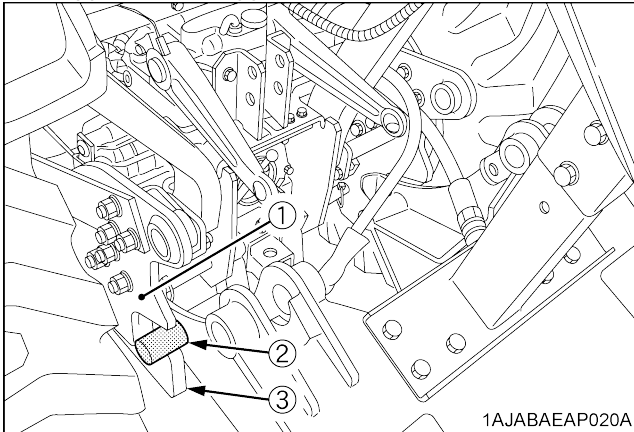

- (1) Guide stop  
(2) Mount bar  
(3) Support hook

7. Move the tractor forward from the backhoe about 200 mm (8 inches).

**IMPORTANT :**

- Be careful not to damage or break the hoses when moving the tractor.

8. Lower the main frame and swing frame onto the ground by operating the boom and stabilizer control levers.

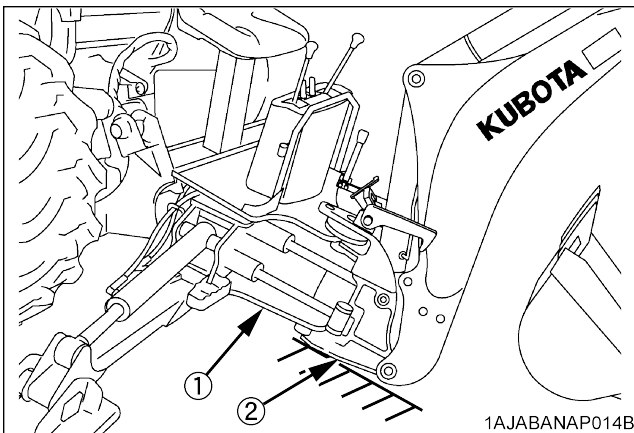

- (1) Main frame  
(2) Swing frame

9. Shut off the engine and set the parking brake.  
10. Slowly release all hydraulic pressure by moving the backhoe hydraulic control levers in all directions.  
11. Disconnect hydraulic hoses in the following manner:  
(1) Disconnect the inlet and outlet hoses from the tractor.  
(2) Connect tractor's outlet hose to the coupler of return hose.

**NOTE :**

- Failure to reconnect the hose can result in severe damage to Hydraulic Pump and seals.  
Do not start tractor with hose disconnected.

**[B3200, B3300SU]**

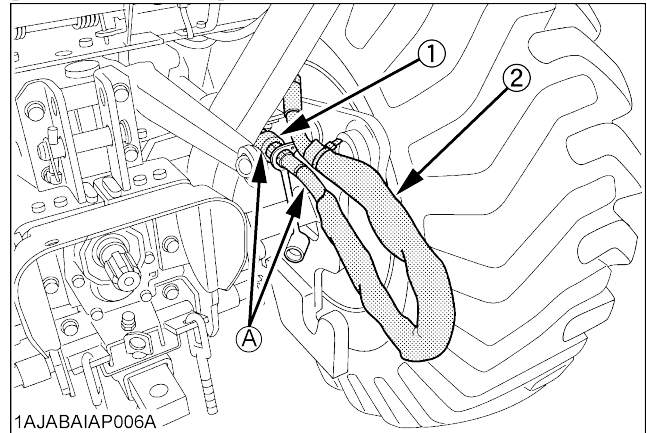

**[B2630, B3030, B3000]**

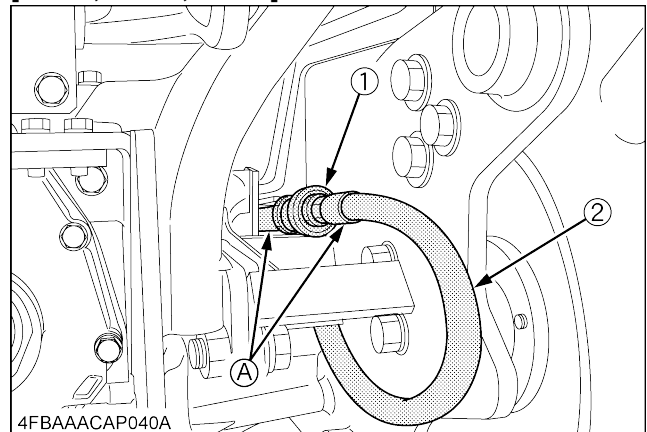

**[B2650CAB, B3350CAB]**

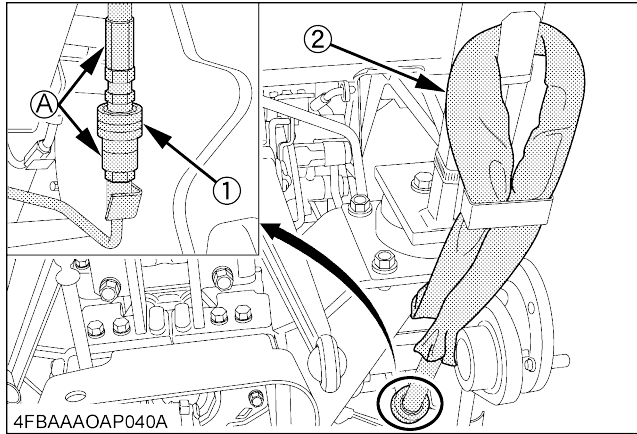

**[L3240(-3), L3540(-3)]**

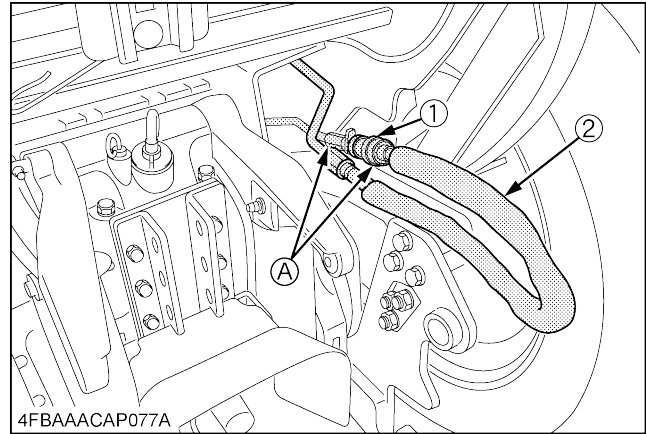

**[B2650ROPS, B3350ROPS, B3350SU]**

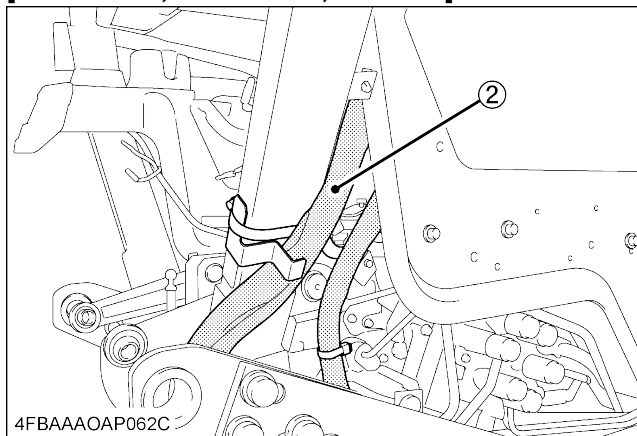

**[L3560]**

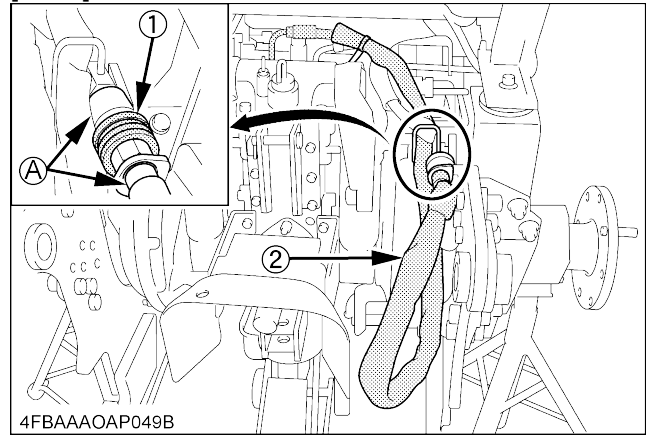

**NOTE :**

- Pass the backhoe outlet hose through the inside of backhoe.

- (1) Coupler
- (A) To be connected
- (2) Outlet hose

**[L2800, L3400, L3700SU, L3200, L3800, L2501, L3301, L3901]**

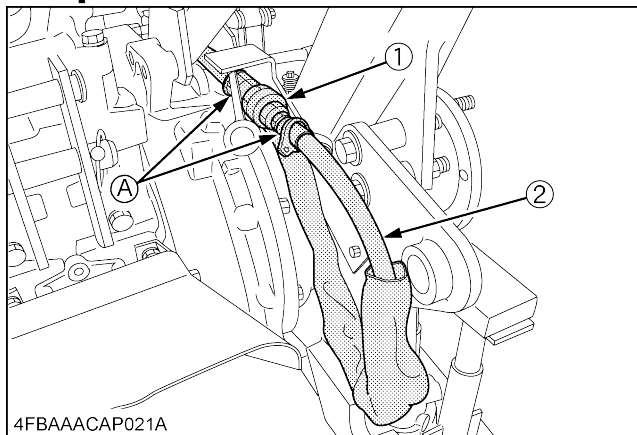

12. Restart the engine.

Then drive the tractor / loader slowly away from the backhoe.

13. Shut off the engine and remove the key from the tractor. Set the parking brake.

**NOTE :**

- The entire three point hitch can now be reinstalled on the tractor for use with other rear mount implements.
- Be sure that there is sufficient ballast in the rear tires and an implement is attached to the three point hitch before using the loader with backhoe removed.

**IMPORTANT :**

- Tractor outlet hose must be connected to tractor return hose when backhoe is removed.

## ■ Storage of The Backhoe

1. Store the backhoe in a dry place.
2. Apply a coat of grease to all exposed cylinder rods to prevent rusting.
3. If the backhoe is being stored outside, cover the backhoe with a suitable weather cover. This will keep moisture, dirt and other airborne debris from getting into the system.
4. Repair or replace any worn, damaged or missing parts.

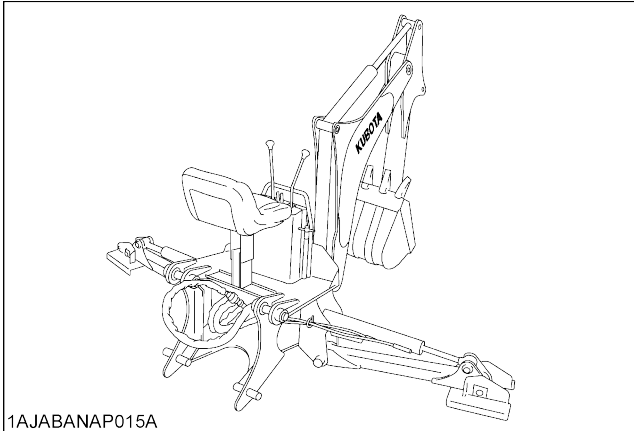

1AJABANAP015A

### IMPORTANT :

- When storing the backhoe, install the dust caps onto the backhoe's hydraulic fittings to prevent contamination.

## PRE-OPERATION CHECK

### ■ Lubrication

Lubricate all grease fittings with SAE multipurpose grease.

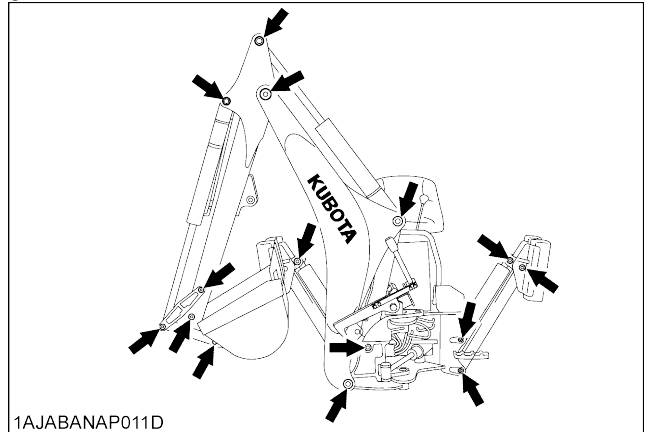

1AJABANAP011D

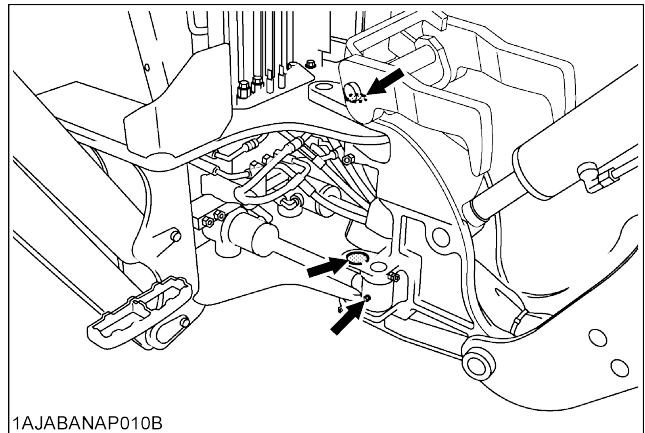

1AJABANAP010B



### ■ Transmission Fluid

Check tractor transmission fluid level. Add fluid if necessary. Refer to the tractor operator's manual for instructions and proper fluid. Repeat this check after purging air from the system. At that time, it will be necessary to add transmission fluid.

**IMPORTANT :**

- If oil level is low, do not run engine.
- When checking the oil level, locate the tractor / loader / backhoe on a flat and level surface and set the loader / backhoe as illustrated.

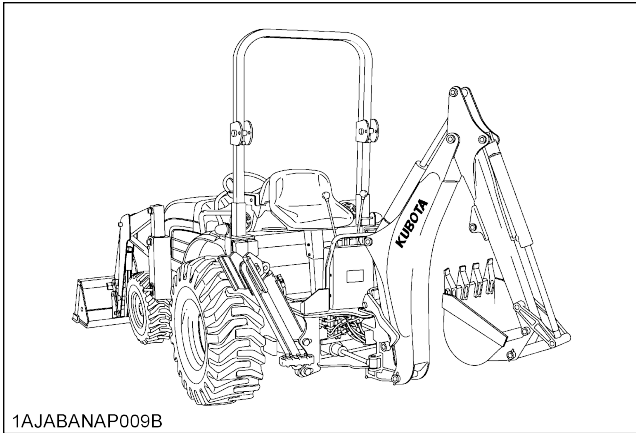

After purging air from the hydraulic circuit, add transmission oil to prescribed level.

**[B3200, B3300SU]**

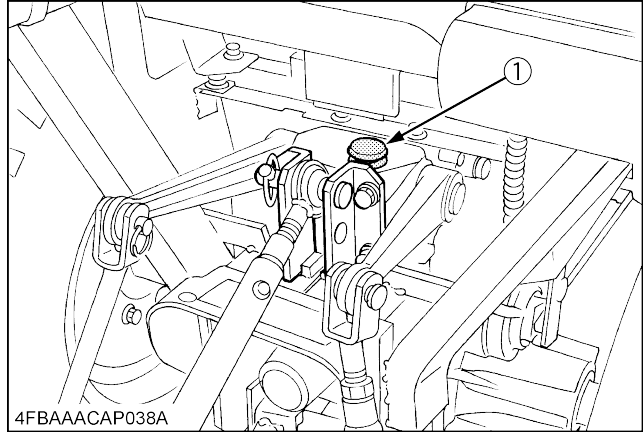

(1) Oil inlet

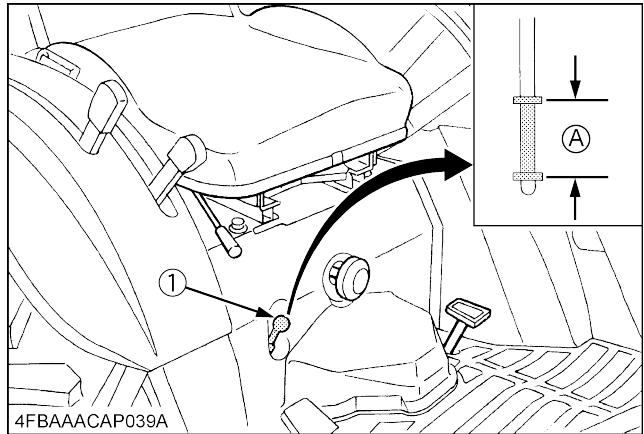

(1) Dipstick (A) Oil level is acceptable within this range

**[B2630/B3030, B3000, B2650/B3350]**

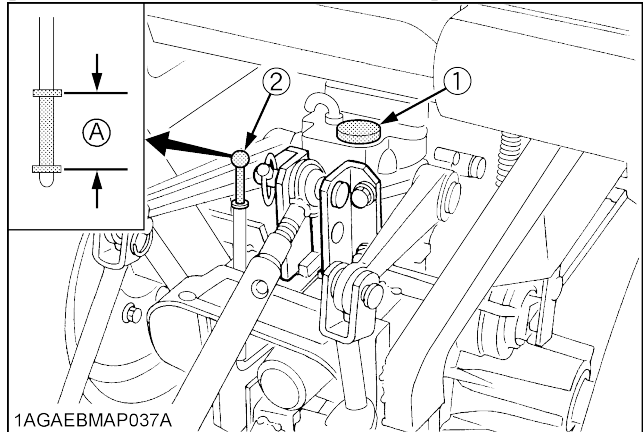

(1) Oil inlet (A) Oil level is acceptable within this range  
(2) Dipstick

**[L3301, L3901]  
[Manual Transmission Type]**

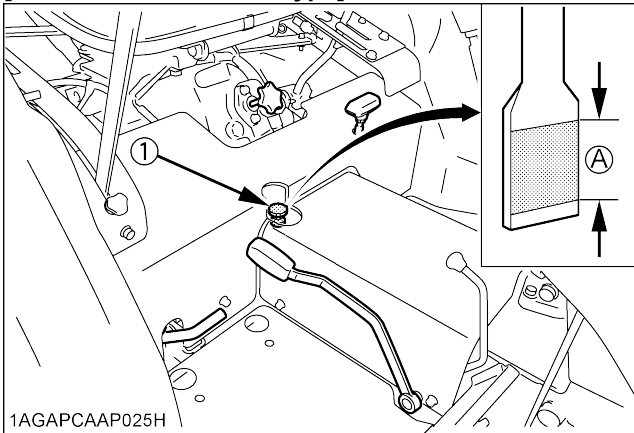

1AGAPCAAP025H

(1) Dipstick (A) Oil level is acceptable within this range

**[L2800, L3400, L3700SU, L3200, L3800, L2501]  
[Manual Transmission Type]**

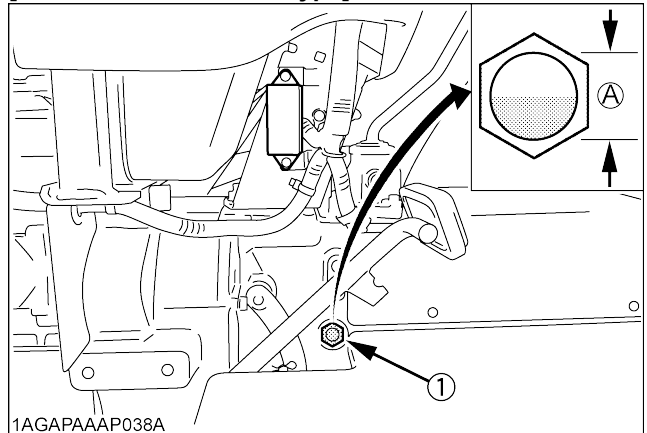

1AGAPAAAP038A

(1) Gauge (A) Oil level is acceptable within this range

**[HST Type]**

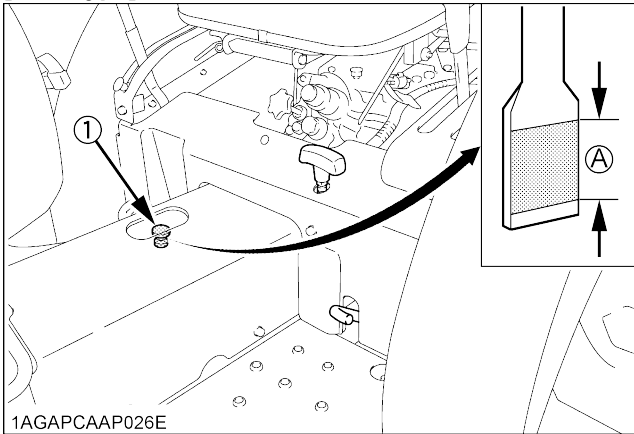

1AGAPCAAP026E

(1) Dipstick (A) Oil level is acceptable within this range

**[HST Type]**

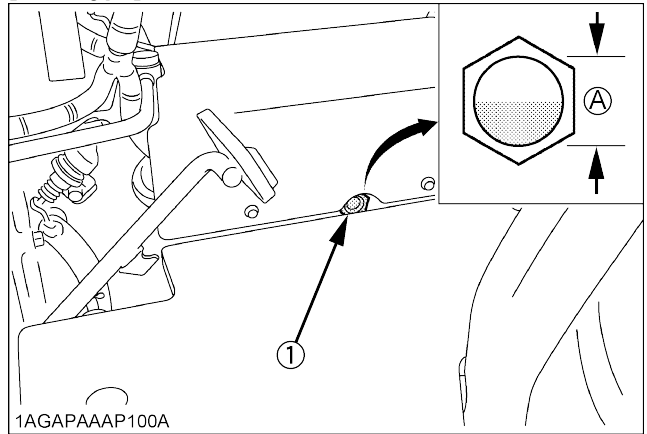

1AGAPAAAP100A

(1) Gauge (A) Oil level is acceptable within this range

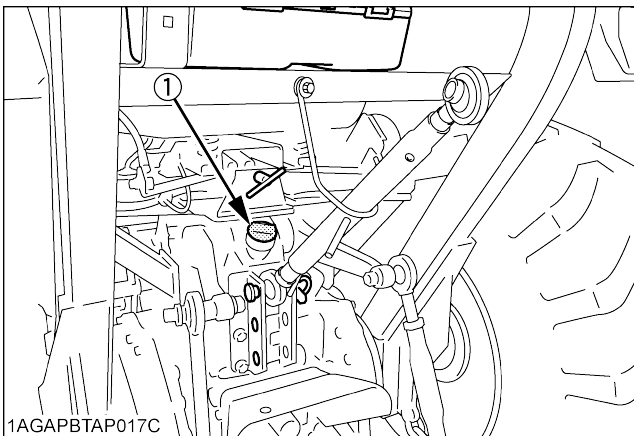

1AGAPBTAP017C

(1) Oil inlet

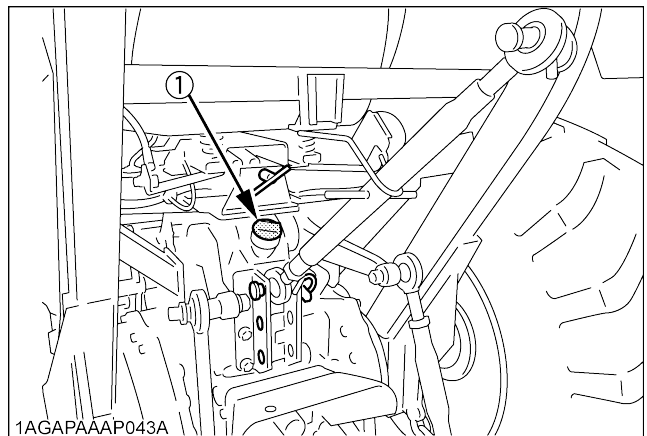

1AGAPAAAP043A

(1) Oil inlet

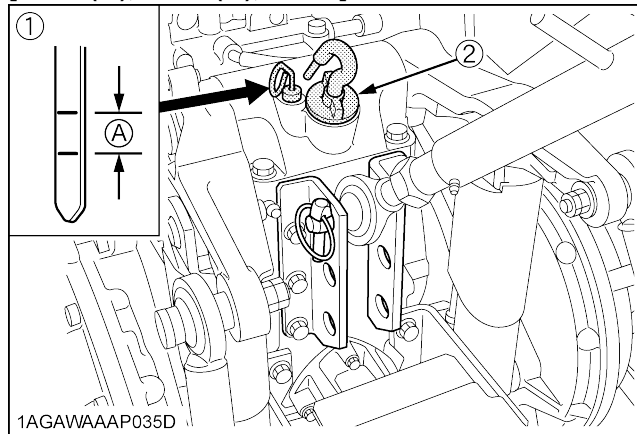
**[L3240(-3), L3540(-3), L3560]**

- (1) Gauge      (A) Oil level is acceptable within this range  
 (2) Oil inlet

**ASSEMBLY TIME**

Refer to the following table for the assembly time to open the crate and assemble the tractor.



Assembly times on the table are just for reference under the following conditions.

1. Assembly by one worker.
2. Following tools and equipment are available.
  - (1) Chain hoist or crane.
  - (2) Impact wrench, Ratchet wrench, Torque wrench, Socket wrench, Spanner wrench.
  - (3) Nylon strap.

B3200 B3300SU B2630 B3030 B3000 B2650 B3350 L2800 L3400 L3700SU L3200 L3800 L2501 L3560 L3301 L3901	1.9 HRS
L3240(-3) L3540(-3)	2.15 HRS

# TIGHTENING TORQUE OF BOLTS AND NUTS

## ■ General Torque Specification

American standard screws, bolts and nuts with UNC or UNF threads				Metric cap screws 		
SAE grade No.	SAE GR.5 	SAE GR.8 	property class	8.8 Approx. SAE GR 5		
1/4 (N-m) (kgf-m) (ft-lbs)	11.7 to 15.8 1.19 to 1.61 8.6 to 11.6	16.3 to 19.8 1.66 to 2.02 12.0 to 14.6	M6 (N-m) (kgf-m) (ft-lbs)	9.8 to 11.2 1.0 to 1.1 7.2 to 8.3		
5/16 (N-m) (kgf-m) (ft-lbs)	23.1 to 27.8 2.35 to 2.83 17.0 to 20.5	32.5 to 39.3 3.31 to 4.01 24.0 to 29.0	M8 (N-m) (kgf-m) (ft-lbs)	23.6 to 27.4 2.4 to 2.8 17.4 to 20.2		
3/8 (N-m) (kgf-m) (ft-lbs)	47.5 to 57.0 4.84 to 5.81 35.0 to 42.0	61.0 to 73.2 6.22 to 7.46 45.0 to 54.0	M10 (N-m) (kgf-m) (ft-lbs)	48.1 to 55.8 4.9 to 5.7 35.5 to 41.2		
1/2 (N-m) (kgf-m) (ft-lbs)	108.5 to 130.2 11.06 to 13.28 80.0 to 96.0	149.2 to 179.0 15.21 to 18.25 110.0 to 132.0	M12 (N-m) (kgf-m) (ft-lbs)	77.5 to 90.1 7.9 to 9.2 57.2 to 66.5		
9/16 (N-m) (kgf-m) (ft-lbs)	149.2 to 179.0 15.21 to 18.25 110.0 to 132.0	217.0 to 260.4 22.13 to 26.55 160.0 to 192.0	M14 (N-m) (kgf-m) (ft-lbs)	124 to 147 12.6 to 15.0 91.5 to 108.4		
5/8 (N-m) (kgf-m) (ft-lbs)	203.4 to 244.1 20.74 to 24.89 150.0 to 180.0	298.3 to 358.0 30.42 to 36.51 220.0 to 264.0	M16 (N-m) (kgf-m) (ft-lbs)	196 to 225 20.0 to 23.0 145 to 166		
			M18 (N-m) (kgf-m) (ft-lbs)	275 to 318 28.0 to 32.5 203 to 235		
			M20 (N-m) (kgf-m) (ft-lbs)	368 to 431 37.6 to 44.0 272 to 318		

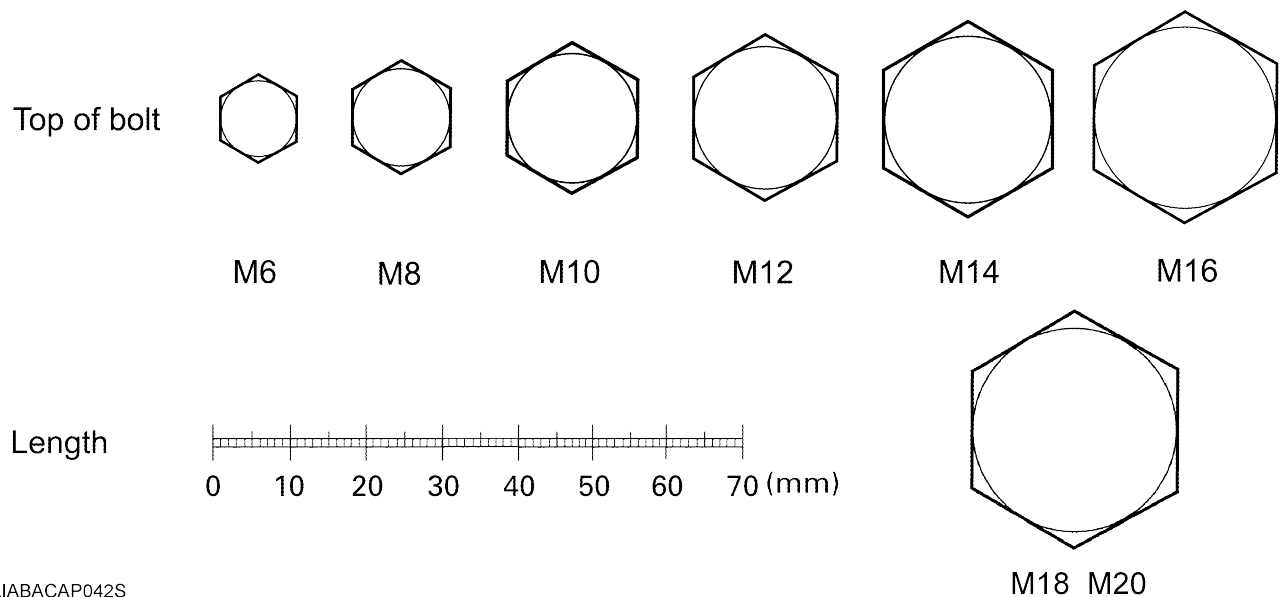

## TIGHTENING TORQUE OF ADAPTORS, ELBOWS AND OTHERS

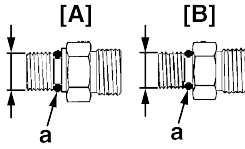
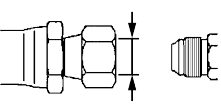
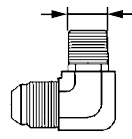
Item	Shape	Thread size	Tightening torque		
			N-m	kgf-m	ft-lbs
Adjustable elbow, Adaptor (O-ring port) (UNF)	 <p>[A] Nut Type [B] No Nut Type a: O-ring</p> <p>4FBAAAKAP064A</p>	9/16	37 to 44	3.8 to 4.5	27 to 33
		3/4	48 to 54	4.9 to 5.5	35 to 40
		7/8	77 to 85	7.9 to 8.6	57 to 62
Hose fitting, Flare nut (UNF)	 <p>4FBAAAKAP065A</p>	9/16	22 to 25	2.3 to 2.6	16 to 19
		3/4	36 to 40	3.6 to 4.1	26 to 30
		7/8	43 to 50	4.4 to 5.0	32 to 36
Adaptor (NPT)	 <p>4FBAAAKAP066A</p>	1/4	30 to 50	3.1 to 5.0	23 to 36
		3/8	39 to 60	4.0 to 6.1	29 to 44
		1/2	49 to 58	5.0 to 5.9	36 to 43

## CHECKLIST FOR INSPECTION AFTER ASSEMBLY

Inspector:	Date completed:
Backhoe model:	Serial No.:

Classification	Inspection items	Result
Assembly	<b>[BH4962, BH4963, BH4984]</b> 1. Check for proper tightening of seat support assy. <b>[BH4962, BH4963]</b> Tightening torque for M8 flange nuts: 23.6 to 27.4 N-m <b>[BH4984]</b> Tightening torque for M10 bolts: 48.1 to 55.8 N-m	
	<b>[BH4963, BH4984]</b> 2. Check for proper tightening of seat stay. Tightening torque for M8 bolts: 23.6 to 27.4 N-m	
	<b>[BH4963]</b> 3. Check for proper tightening of seat belt LH and RH. Tightening torque for M10 flange bolts: 48.1 to 55.8 N-m	
	<b>[BH4962, BH4963]</b> 4. Check for proper tightening torque of seat belt stay LH and RH. Tightening torque for M10 flange nuts: 48.1 to 55.8 N-m	
	<b>[BH4962, BH4963, BH4984]</b> 5. Check that the snap pin of seat joint pin is inserted surely.	
	<b>[BH4985, BH4986, BH4996A]</b> 6. Check for proper tightening of floor seat cover. Tightening torque for M8 bolts and nuts: 23.6 to 27.4 N-m	
	<b>[BH4972, BH4973, BH4975B, BH4976A, BH4985, BH4986, BH4988, BH4996A]</b> 7. Check for proper tightening of backhoe seat. Tightening torque for 5/16" bolts: 19.0 to 23.1 N-m	
	<b>[BH4972, BH4973, BH4975B, BH4976A, BH4985, BH4986, BH4988, BH4996A]</b> 8. Check for proper tightening of seat support assy. Tightening torque for M12 flange bolts and nuts: 77.5 to 90.1 N-m	
	<b>[All tractors]</b> 9. Check for proper tightening of rear tires. <b>[B3200, B3300SU, B2630, B3030, B3000, B2650, B3350, B3350SU]</b> Tightening torque for M16 bolts: 196 to 225 N-m Tightening torque for M16 nuts: 167 to 191 N-m <b>[L2800, L3400, L3700SU, L3200, L3800, L2501, L3301, L3901, L3240(-3), L3540(-3), L3560]</b> Tightening torque for M16 bolts and nuts: 215 N-m	