

# Rotary Cutter

RCR1242, RCR1248, RCR1260 & RCR1272

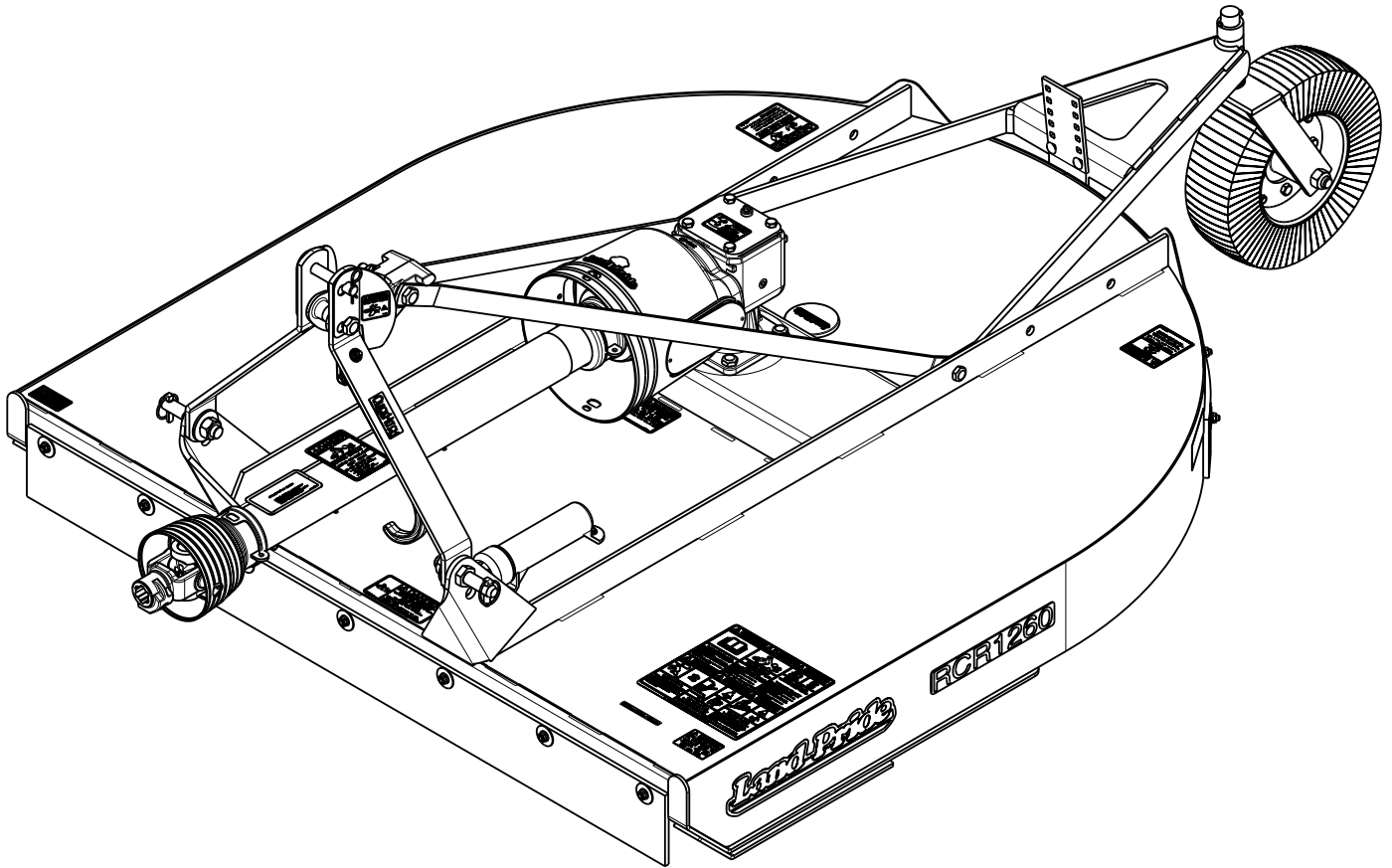

30287

## 326-047M Operator's Manual



Read the Operator's Manual entirely. When you see this symbol, the subsequent instructions and warnings are serious - follow without exception. Your life and the lives of others depend on it!

**Cover photo may show optional equipment not supplied with standard unit.**

**For an Operator's Manual and Decal Kit in French or Spanish Language, please see your Land Pride dealer.**



## Machine Identification

Record your machine details in the log below. If you replace this manual, be sure to transfer this information to the new manual.

If you, or the dealer, have added Options not originally ordered with the machine, or removed Options that were originally ordered, the weights and measurements are no longer accurate for your machine. Update the record by adding the machine weight and measurements provided in the Specifications & Capacities Section of this manual with the Option(s) weight and measurements.

<b>Model Number</b>	
<b>Serial Number</b>	
<b>Machine Height</b>	
<b>Machine Length</b>	
<b>Machine Width</b>	
<b>Machine Weight</b>	
<b>Delivery Date</b>	
<b>First Operation</b>	
<b>Accessories</b>	<hr/> <hr/> <hr/>

## Dealer Contact Information

**Name:** \_\_\_\_\_

**Street:** \_\_\_\_\_

**City/State:** \_\_\_\_\_

**Telephone:** \_\_\_\_\_

**Email:** \_\_\_\_\_

 <b>WARNING:</b> Cancer and reproductive harm - <a href="http://www.P65Warnings.ca.gov">www.P65Warnings.ca.gov</a>
---



<b>Important Safety Information</b> . . . . .	<b>1</b>	<b>Section 5: Maintenance &amp; Lubrication</b> . . . . .	<b>28</b>
Safety at All Times . . . . .	1	Maintenance . . . . .	28
Look for the Safety Alert Symbol . . . . .	1	Hydraulic System . . . . .	28
Safety Labels . . . . .	6	Cutter Blade Maintenance . . . . .	28
<b>Introduction</b> . . . . .	<b>11</b>	Driveline Maintenance . . . . .	30
Application . . . . .	11	Driveline with Shear Bolt Clutch . . . . .	30
Using This Manual . . . . .	11	Driveline with Slip Clutch . . . . .	31
Owner Assistance . . . . .	11	Clutch Run-In . . . . .	31
<b>Section 1: Assembly &amp; Set-up</b> . . . . .	<b>12</b>	Clutch Disassembly . . . . .	32
Tractor Requirements . . . . .	12	Clutch Assembly . . . . .	32
Dealer Preparations . . . . .	12	Long-Term Storage . . . . .	33
Hitch & Tailwheel Assembly . . . . .	12	Ordering Replacement Parts . . . . .	33
Gearbox Vented Plug . . . . .	14	Lubrication Points . . . . .	34
Front Rubber Deflector Assembly . . . . .	14	Gauge Wheel Spindle Tube . . . . .	34
Driveline Installation . . . . .	15	Gauge Wheel Hub . . . . .	34
3-Point Hook-Up . . . . .	16	Gearbox Input Shaft . . . . .	34
Driveline Hook-Up . . . . .	17	Gearbox . . . . .	35
Check Driveline Collapsible Length . . . . .	18	Driveline U-Joints . . . . .	35
Reassemble Driveline . . . . .	18	Driveline Shield Bearings . . . . .	35
Check Driveline Interference . . . . .	19	Driveline Profiles . . . . .	35
<b>Section 2: Accessories</b> . . . . .	<b>20</b>	<b>Section 6: Specifications &amp; Capacities</b> . . . . .	<b>36</b>
Replaceable Skid Shoes (Accessory) . . . . .	20	<b>Section 7: Features &amp; Benefits</b> . . . . .	<b>38</b>
<b>Section 3: Adjustments</b> . . . . .	<b>21</b>	<b>Section 8: Troubleshooting</b> . . . . .	<b>39</b>
Deck Leveling & Cutting Height . . . . .	21	<b>Section 9: Torque Values Chart</b> . . . . .	<b>40</b>
Deck Leveling Left to Right . . . . .	21	<b>Section 10: Warranty</b> . . . . .	<b>41</b>
Cutting Height Adjustment . . . . .	21		
Center 3-Point Link Adjustment . . . . .	22		
Tailwheel Height Adjustment . . . . .	22		
<b>Section 4: Operating Procedures</b> . . . . .	<b>23</b>		
Operating Checklist . . . . .	23		
Inspection of Tractor & Cutter . . . . .	23		
Safety Information . . . . .	24		
Tractor Shutdown Procedure . . . . .	25		
Transporting . . . . .	25		
Blade Engagement & Disengagement . . . . .	25		
Blade Engagement . . . . .	25		
Blade Disengagement . . . . .	25		
Field Operation . . . . .	26		
Unhook Rotary Cutter . . . . .	26		
General Operating Instructions . . . . .	27		



© Copyright 2022 All rights Reserved

Land Pride provides this publication “as is” without warranty of any kind, either expressed or implied. While every precaution has been taken in the preparation of this manual, Land Pride assumes no responsibility for errors or omissions. Neither is any liability assumed for damages resulting from the use of the information contained herein. Land Pride reserves the right to revise and improve its products as it sees fit. This publication describes the state of this product at the time of its publication, and may not reflect the product in the future.

Land Pride is a registered trademark.

All other brands and product names are trademarks or registered trademarks of their respective holders.

Printed in the United States of America.

See previous page for Table of Contents.



### ***Parts Manual QR Locator***

The QR (Quick Reference) code on the left will take you to the Parts Manual for this equipment. Download the appropriate App on your smart phone, open the App, point your phone on the QR code and take a picture.



### ***Dealer QR Locator***

The QR code on the left will link you to available dealers for Land Pride products. Refer to Parts Manual QR Locator on this page for detailed instructions.



Listed below are common practices that may or may not be applicable to the products described in this manual.

### Safety at All Times

Careful operation is your best assurance against an accident.

All operators, no matter how much experience they may have, should carefully read this manual and other related manuals, or have the manuals read to them, before operating the power machine and this implement.

- ▲ Thoroughly read and understand the "Safety Label" section. Read all instructions noted on them.
- ▲ Do not operate the equipment while under the influence of drugs or alcohol as they impair the ability to safely and properly operate the equipment.
- ▲ The operator should be familiar with all functions of the tractor and attached implement, and be able to handle emergencies quickly.
- ▲ Make sure all guards and shields appropriate for the operation are in place and secured before operating the implement.
- ▲ Keep all bystanders away from equipment and work area.
- ▲ Start tractor from the driver's seat with hydraulic controls in neutral.
- ▲ Operate tractor and controls from the driver's seat only.
- ▲ Never dismount from a moving tractor or leave tractor unattended with engine running.
- ▲ Do not allow anyone to stand between tractor and implement while backing up to implement.
- ▲ Keep hands, feet, and clothing away from power-driven parts.
- ▲ While transporting and operating equipment, watch out for objects overhead and along side such as fences, trees, buildings, wires, etc.
- ▲ Do not turn tractor so tight as to cause hitched implement to ride up on the tractor's rear wheel.
- ▲ Store implement in a safe and secure area where children normally do not play. When needed, secure implement against falling with support blocks.



### Look for the Safety Alert Symbol

The SAFETY ALERT SYMBOL indicates there is a potential hazard to personal safety and extra precaution must be taken. When you see this symbol, be alert and carefully read the message that follows it. Hazard control, and accident prevention are dependent upon the awareness, concern, prudence, and proper training of personnel involved in the operation, transport, maintenance, and storage of equipment.

### Be Aware of Signal Words

A signal word designates a degree or level of hazard seriousness. They are:

- ▲ **DANGER:** Indicates a hazardous situation that, if not avoided, will result in death or serious injury.
- ▲ **WARNING:** Indicates a hazardous situation that, if not avoided, could result in death or serious injury.
- ▲ **CAUTION:** Indicates a hazardous situation that, if not avoided, may result in minor or moderate injury.

### Be Aware of Special Notices

Special notices are intended to point out important and helpful information that should be followed. They are usually placed inside a box. They are:

- ▲ **IMPORTANT:** Indicates that equipment or property damage could result if instructions are not followed.
- ▲ **NOTE:** Indicates supplementary explanations that will be helpful when using the equipment.

### Safety Precautions for Children

Tragedy can occur if the operator is not alert to the presence of children, Children generally are attracted to implements and their work.

- ▲ Never assume children will remain where you last saw them.
- ▲ Keep children out of the work area and under the watchful eye of a responsible adult.
- ▲ Be alert and shut the implement and tractor down if children enter the work area.
- ▲ Never carry children on the tractor or implement. There is not a safe place for them to ride. They may fall off and be run over or interfere with the control of the power machine.
- ▲ Never allow children to operate the power machine, even under adult supervision.
- ▲ Never allow children to play on the power machine or implement.
- ▲ Use extra caution when backing up. Before the tractor starts to move, look down and behind to make sure the area is clear.

### Tractor Shutdown & Storage

- ▲ If engaged, disengage power take-off.
- ▲ Park on solid, level ground and lower implement to ground or onto support blocks.
- ▲ Put tractor in park or set park brake.
- ▲ Turn off engine and remove ignition key to prevent unauthorized starting.
- ▲ Relieve all hydraulic pressure to auxiliary hydraulic lines.
- ▲ Wait for all components to stop before leaving operator's seat.
- ▲ Use steps, grab-handles and anti-slip surfaces when stepping on and off the tractor.

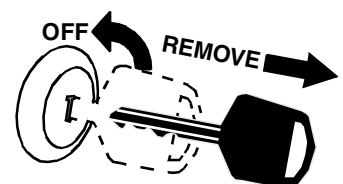

Listed below are common practices that may or may not be applicable to the products described in this manual.

### Use A Safety Chain

- ▲ A safety chain will help control drawn machinery should it separate from the tractor drawbar.
- ▲ Use a chain with the strength rating equal to or greater than the gross weight of the towed implement.
- ▲ Attach the chain to the tractor drawbar support or other specified anchor location. Allow only enough slack in the chain to permit turning.
- ▲ Always hitch the implement to the machine towing it. Do not use the safety chain to tow the implement.

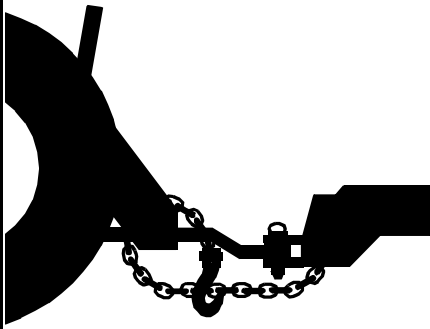

### Transport Safely

- ▲ Comply with federal, state, and local laws.
- ▲ Use towing vehicle and trailer of adequate size and capacity. Secure equipment towed on a trailer with tie downs and chains.
- ▲ Sudden braking can cause a towed trailer to swerve unexpectedly. Reduce speed if towed trailer is not equipped with brakes.
- ▲ Avoid contact with any overhead utility lines or electrically charged conductors.
- ▲ Always drive with load on end of loader arms low to the ground.
- ▲ Always drive straight up and down steep inclines with heavy end of skid steer on the "uphill" side.
- ▲ Engage park brake when stopped on an incline.
- ▲ Maximum transport speed for an attached equipment is 20 mph (32 km/h). **DO NOT EXCEED.** Never travel at a speed which does not allow adequate control of steering and stopping. Some rough terrains require a slower speed.
- ▲ As a guideline, use the following maximum speed weight ratios for attached equipment:
  - 20 mph (32 km/h)** when weight of attached equipment is less than or equal to the weight of machine towing the equipment.
  - 10 mph (16 km/h)** when weight of attached equipment exceeds weight of machine towing equipment but not more than double the weight.
- ▲ **IMPORTANT:** Do not tow a load that is more than double the weight of the vehicle towing the load.

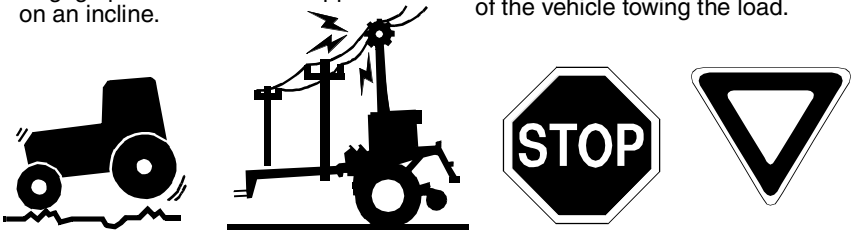

### Tire Safety

- ▲ Tire changing can be dangerous and must be performed by trained personnel using the correct tools and equipment.
- ▲ Always properly match the wheel size to the properly sized tire.
- ▲ Always maintain correct tire pressure. Do not inflate tires above recommended pressures shown in the Operator's Manual.
- ▲ When inflating tires, use a clip-on chuck and extension hose long enough to allow you to stand to one side and NOT in front of or over the tire assembly. Use a safety cage if available.
- ▲ Securely support the implement when changing a wheel.
- ▲ When removing and installing wheels, use wheel handling equipment adequate for the weight involved.
- ▲ Make sure wheel bolts have been tightened to the specified torque.



### Practice Safe Maintenance

- ▲ Understand procedure before doing work. Refer to the Operator's Manual for additional information.
- ▲ Work on a level surface in a clean dry area that is well-lit.
- ▲ Lower implement to the ground and follow all shutdown procedures before leaving the operator's seat to perform maintenance.
- ▲ Do not work under any hydraulically supported equipment. It can settle, suddenly leak down, or be lowered accidentally. If it is necessary to work under the equipment, securely support it with stands or suitable blocking beforehand.
- ▲ Use properly grounded electrical outlets and tools.
- ▲ Use correct tools and equipment for the job that are in good condition.
- ▲ Allow equipment to cool before working on it.
- ▲ Disconnect battery ground cable (-) before servicing or adjusting electrical systems or before welding on implement.
- ▲ Inspect all parts. Make certain parts are in good condition & installed properly.
- ▲ Replace parts on this implement with genuine Land Pride parts only. Do not alter this implement in a way which will adversely affect its performance.
- ▲ Do not grease or oil implement while it is in operation.
- ▲ Remove buildup of grease, oil, or debris.
- ▲ Always make sure any material and waste products from the repair and maintenance of the implement are properly collected and disposed.
- ▲ Remove all tools and unused parts from equipment before operation.
- ▲ Do not weld or torch on galvanized metal as it will release toxic fumes.



Listed below are common practices that may or may not be applicable to the products described in this manual.

**Prepare for Emergencies**

- ▲ Be prepared if a fire starts.
- ▲ Keep a first aid kit and fire extinguisher handy.
- ▲ Keep emergency numbers for doctor, ambulance, hospital, and fire department near the phone.

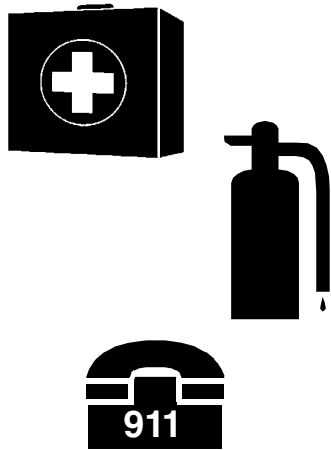

**Wear Personal Protective Equipment (PPE)**

- ▲ Wear protective clothing and equipment appropriate for the job such as safety shoes, safety glasses, hard hat, dust mask, and ear plugs.
- ▲ Clothing should fit snug without fringes and pull strings to avoid entanglement with moving parts.
- ▲ Prolonged exposure to loud noise can cause hearing impairment or hearing loss. Wear suitable hearing protection such as earmuffs or earplugs.
- ▲ Operating a machine safely requires the operator's full attention. Avoid wearing headphones while operating equipment.



**Avoid High Pressure Fluids**

- ▲ Escaping fluid under pressure will penetrate the skin or eyes causing serious injury.
- ▲ Relieve all residual pressure before disconnecting hydraulic lines or performing work on the hydraulic system.
- ▲ Make sure all hydraulic fluid connections are properly tightened/torqued and all hydraulic hoses and lines are in good condition before applying pressure to the system.
- ▲ Use a piece of paper or cardboard, NOT BODY PARTS, to check for suspected leaks.
- ▲ Wear protective gloves and safety glasses or goggles when working with hydraulic systems.
- ▲ **DO NOT DELAY.** If an accident occurs, seek immediate emergency medical care or gangrene may result.



**Use Safety Lights and Devices**

- ▲ A Slow moving power machine can create a hazard when driven on public roads. They are difficult to see, especially at night. Use the Slow Moving Vehicle (SMV) sign when on public roads.
- ▲ Flashing warning lights and turn signals are recommended whenever driving on public roads.

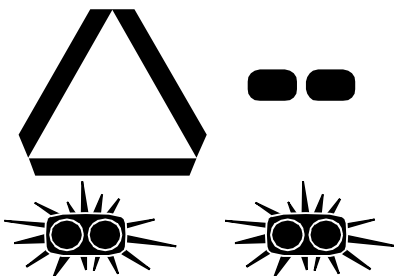

**Use Seat Belt and ROPS**

- ▲ Land Pride recommends the use of a CAB or roll-over-protective-structures (ROPS) and seat belt in almost all power machines. Combination of a CAB or ROPS and seat belt will reduce the risk of serious injury or death if the power machine should be upset.
- ▲ If ROPS is in the locked-up position, fasten seat belt snugly and securely to help protect against serious injury or death from falling and machine overturn.

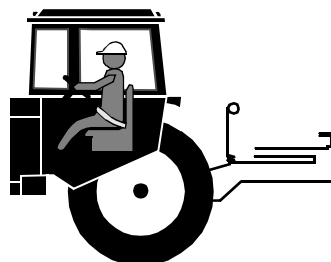

**Keep Riders Off Machinery**

- ▲ Never carry riders on the tractor or implement.
- ▲ Riders obstruct operator's view and interfere with the control of the power machine.
- ▲ Riders can be struck by objects or thrown from the equipment.
- ▲ Never use the tractor or implement to lift or transport riders.

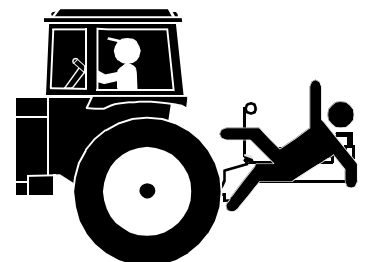

Listed below are common practices that may or may not be applicable to the products described in this manual.

### Avoid crystalline Silica (quartz) Dust

Because crystalline silica is a basic component of sand and granite, many activities at construction sites produce dust containing crystalline silica. Trenching, sawing, and boring of material containing crystalline silica can produce dust containing crystalline silica particles. This dust can cause serious injury to the lungs (silicosis).

There are guidelines which should be followed if crystalline silica (quartz) is present in the dust.



- ▲ Be aware of and follow OSHA (or other local, State, or Federal) guidelines for exposure to airborne crystalline silica.
- ▲ Know the work operations where exposure to crystalline silica may occur.
- ▲ Participate in air monitoring or training programs offered by the employer.
- ▲ Be aware of and use optional equipment controls such as water sprays, local exhaust ventilation, and enclosed cabs with positive pressure air conditioning if the machine has such equipment. Otherwise respirators shall be worn.
- ▲ Where respirators are required, wear a respirator approved for protection against crystalline silica containing dust. Do not alter respirator in any way. Workers who use tight-fitting respirators can not have beards/mustaches which interfere with the respirator seal to the face.
- ▲ If possible, change into disposable or washable work clothes at the work site; shower and change into clean clothing before leaving the work site.
- ▲ Do not eat, drink, use tobacco products, or apply cosmetics in areas where there is dust containing crystalline silica.
- ▲ Store food, drink, and personal belongings away from the work area.
- ▲ Wash hands and face before eating, drinking, smoking, or applying cosmetics after leaving the exposure area.

### Handle Chemicals Properly

- ▲ Protective clothing should be worn.
- ▲ Handle all chemicals with care.
- ▲ Follow instructions on container label.
- ▲ Agricultural chemicals can be dangerous. Improper use can seriously injure persons, animals, plants, soil, and property.
- ▲ Inhaling smoke from any type of chemical fire can be a serious health hazard.
- ▲ Store or dispose of unused chemicals as specified by the chemical manufacturer.



### Dig Safe - Avoid Underground Utilities

- ▲ **USA: Call 811**  
**CAN: [digsafecanada.ca](http://digsafecanada.ca)**  
Always contact your local utility companies (electrical, telephone, gas, water, sewer, and others) before digging so that they may mark the location of any underground services in the area.
- ▲ Be sure to ask how close you can work to the marks they positioned.





This page left blank intentionally.



## Important Safety Information

### Safety Labels

Your Rotary Cutter comes equipped with all safety labels in place. They were designed to help you safely operate your implement. Read and follow their directions.

1. Keep all safety labels clean and legible.
2. Refer to this section for proper label placement. Replace all damaged or missing labels. Order new labels from your nearest Land Pride dealer. To find your nearest dealer, visit our dealer locator at [www.landpride.com](http://www.landpride.com).
3. Some new equipment installed during repair requires safety labels to be affixed to the replaced component as

specified by Land Pride. When ordering new components make sure the correct safety labels are included in the request.

4. Refer to this section for proper label placement. To install new labels:
  - a. Clean surface area where label is to be placed.
  - b. Spray soapy water onto the cleaned area.
  - c. Peel backing from label and press label firmly onto the surface.
  - d. Squeeze out air bubbles with edge of a credit card or with a similar type of straight edge.

70376

<b>⚠ WARNING</b>	<b>⚠ DANGER</b>	<b>⚠ DANGER</b>	
<p>To prevent serious injury or death:</p> <ul style="list-style-type: none"> <li>• Do not operate or work on this machine without reading and understanding the Operator's Manual.</li> <li>• Avoid unsafe operation or maintenance.</li> <li>• Transport with clean reflectors, SMV, and lights as required by federal, state, and local laws.</li> <li>• If manual is lost, contact your nearest dealer for a new manual.</li> </ul>	<p><b>ROTATING DRIVELINE CONTACT CAN CAUSE DEATH KEEP AWAY!</b></p> <p><b>DO NOT OPERATE WITHOUT:</b></p> <ul style="list-style-type: none"> <li>• All driveline guards, tractor and equipment shields in place.</li> <li>• Drivelines securely attached at both ends.</li> <li>• Driveline guards that turn freely on driveline.</li> </ul> <p><b>DO NOT USE PTO ADAPTORS</b></p>	<p><b>THROWN OBJECT AND ROTATING BLADE HAZARD</b></p> <p>To prevent serious injury or death:</p> <ul style="list-style-type: none"> <li>• Do not operate unless all guards are installed and in good condition.</li> <li>• Inspect and clear debris from mowing area prior to mowing.</li> <li>• Do not operate with bystanders in or around mowing area.</li> <li>• Do not place hands or feet under deck when operating or when engine is running.</li> <li>• Do not dismount until blades come to a complete stop.</li> </ul>	
<b>⚠ WARNING</b>	<b>⚠ WARNING</b>	<b>⚠ WARNING</b>	
<p><b>CRUSHING HAZARD</b></p> <p>Before performing maintenance on machine and to prevent serious injury or death:</p> <ul style="list-style-type: none"> <li>• Read and understand operator's manual.</li> <li>• Stop engine, set brake, and wait for all moving parts to stop before dismounting.</li> <li>• Support cutter securely before working beneath.</li> </ul>	<p><b>RUN OVER HAZARD</b></p> <p>To prevent serious injury or death:</p> <ul style="list-style-type: none"> <li>• Always use seat belt when operating.</li> <li>• Never allow riders on tractor or machine.</li> </ul>	<p><b>ROLLOVER HAZARD</b></p> <p>To prevent serious injury or death:</p> <ul style="list-style-type: none"> <li>• Always use seat belt when operating.</li> <li>• Only operate on tractors equipped with a rollover protective structure (ROPS).</li> <li>• If equipped with foldable ROPS, only operate in the unfolded and locked position.</li> <li>• Use caution when mowing along inclines.</li> </ul> <p style="text-align: right; font-size: small;">844-190C REV.A</p>	

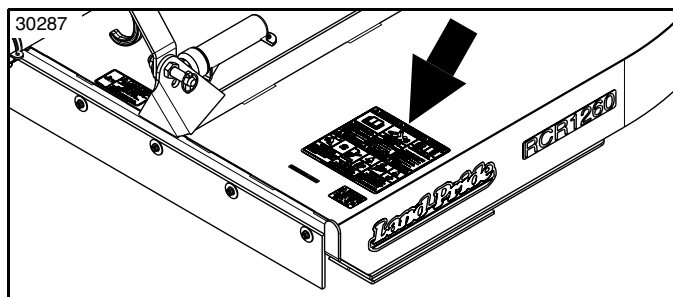

### 844-190C

Danger/Warning Safety Combo: List of Safety Hazards  
1 - Place: At the front of the deck on the left side

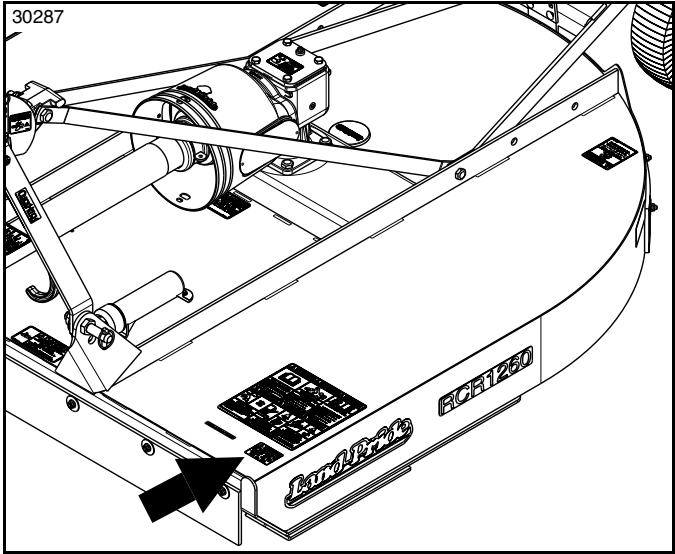

70382

**818-130C**

Warning: Operate with 540 rpm Power Take-off Speed  
1 Place: At the front of the deck on the left side

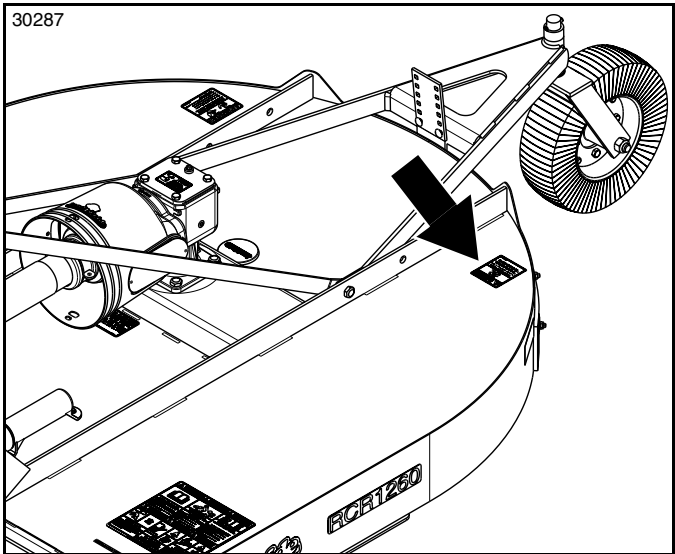

70376

**818-556C**

Danger: Thrown Object Hazard  
1 Place: At the back of the deck on the left side

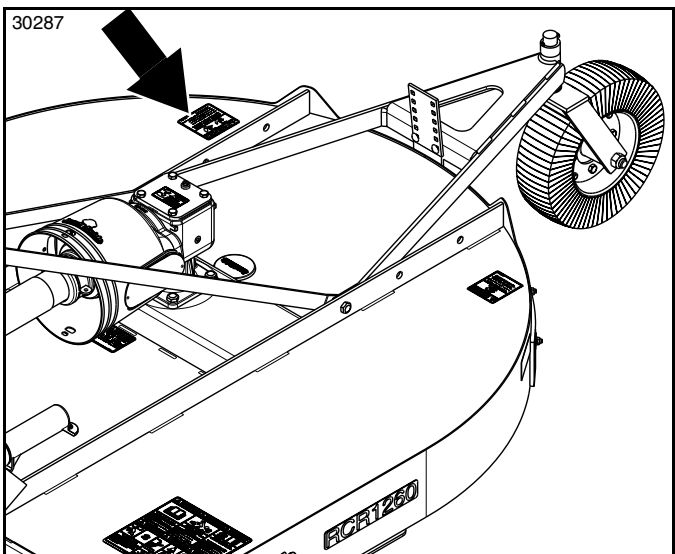

70266

**818-555C**

Danger: Rotating Blade Hazard  
1 Place: At the back of the deck on the right side



Important Safety Information

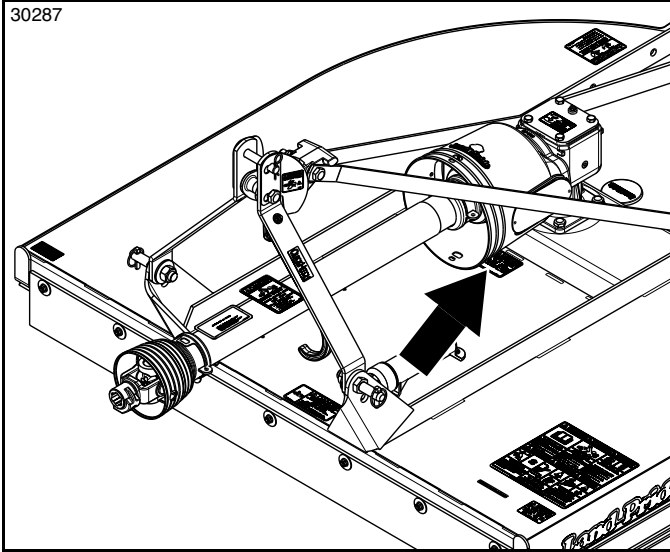

70358

**818-543C**

Danger: Guard Missing Hazard - Do not Operate

1 Place: Beneath the gearbox/driveline shield

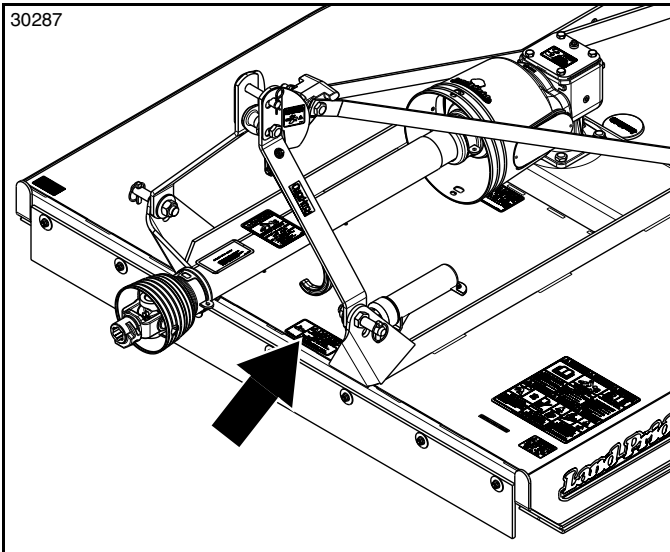

70249

**818-142C**

Danger: Rotating Driveline Entanglement Hazard

1 Place: At the front of the deck

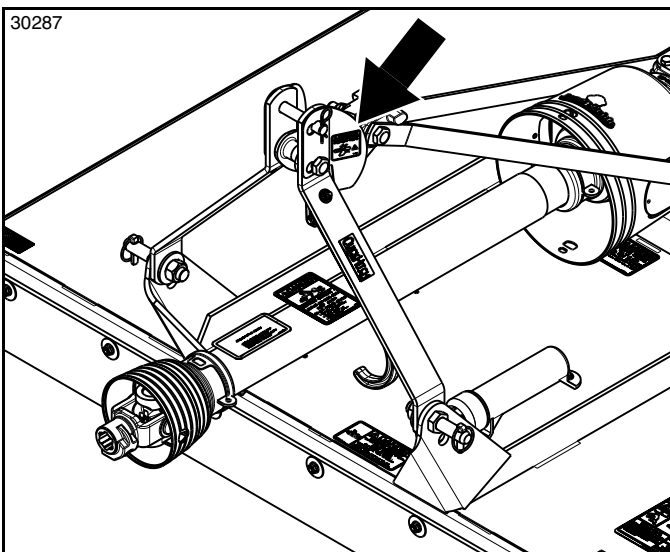

70247

**858-148C**

Warning: Pinch Point Hazard

1 Place



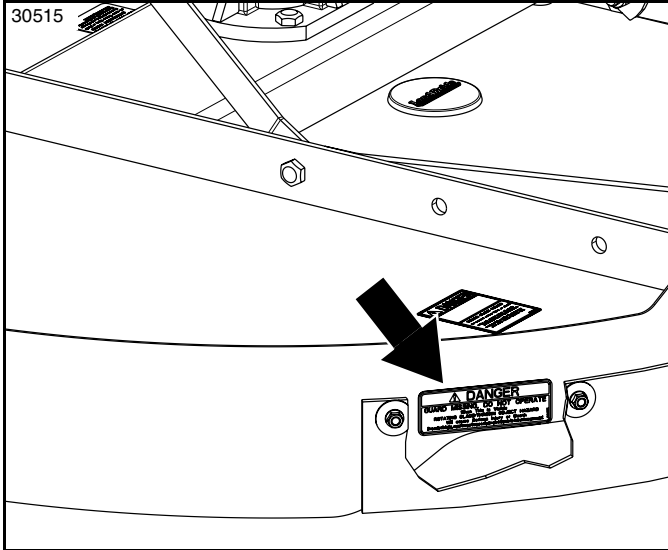

70252

**848-088C**

Danger: Guard Missing Hazard, Do Not Operate

1 Place: Located behind the rear guard on models RCR1248, RCR1260, & RCR1272 only

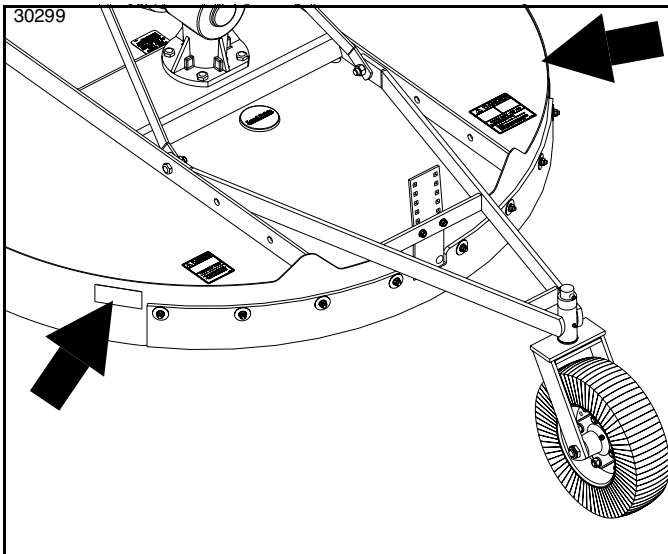

70486

**858-095C**

Red Reflector: 2" x 4 1/2"

2 Places: On the left and right back side of the deck

Important Safety Information

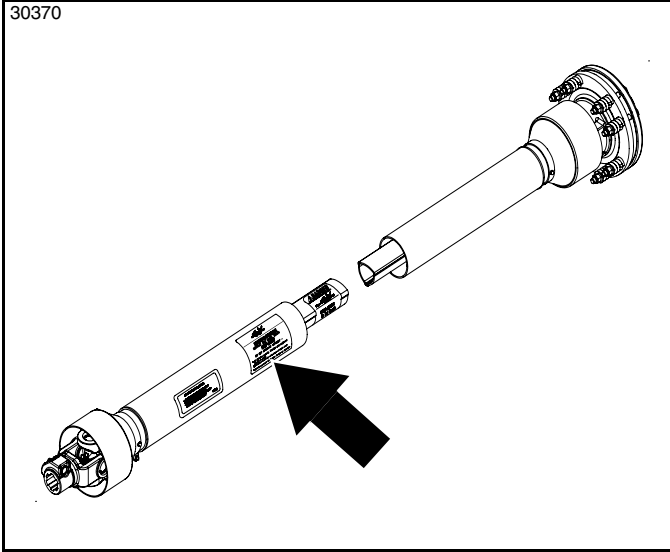

70375



**818-552C**

Danger: Rotating Driveline - Keep Away

1 Place: On the driveline

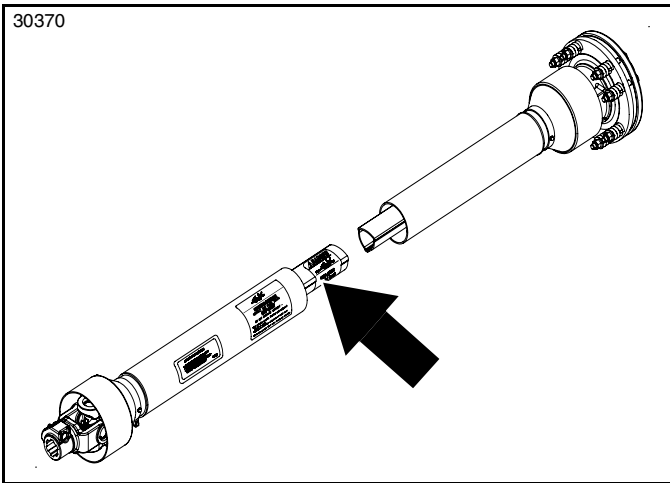

70374



**818-540C**

Danger: Guard Missing - DO NOT Operate

1 Place: On the driveline inner profile

## Introduction

Land Pride welcomes you to the growing family of new product owners. This Rotary Cutter has been designed with care and built by skilled workers using quality materials. Proper assembly, maintenance, and safe operating practices will help you get years of satisfactory use from this Implement.

## Application

Land Pride's RCR12 Series Rotary Cutters are ideal for clearing grass, weeds, and light brush. These cutters offer fast, clean, dependable mowing, and have been extensively tested to ensure operating safety. High blade tip speeds assure a clean cut in a variety of field conditions. The standard stump jumper slides over stumps, rocks, and debris and safety guards keep you up and running.

See "**Specifications & Capacities**" on page 36 and "**Features & Benefits**" on page 38 for additional information and performance enhancing options.

## Using This Manual

- This Operator's Manual is designed to help familiarize the operator with safety, assembly, operation, adjustments, troubleshooting, and maintenance. Read this manual and follow the recommendations to help ensure safe and efficient operation.
- The information contained within this manual was current at the time of printing. Some parts may change slightly to assure you of the best performance.
- To buy a new Operator's or Parts Manual, contact your authorized dealer. Manuals can also be downloaded, free-of-charge, from our website at [www.landpride.com](http://www.landpride.com)

## Terminology

"Right" or "Left" as used in this manual is determined by the direction the operator faces while sitting looking forward in the operator's seat unless otherwise stated.

## Owner Assistance

The dealer should complete the Online Warranty Registration at the time of purchase. This information is necessary to provide you with quality customer service.

The parts on your Rotary Cutter have been specially designed by Land Pride and should only be replaced with genuine Land Pride parts. Contact a Land Pride dealer if customer service or repair parts are required. Your Land Pride dealer has trained personnel, repair parts, and equipment needed to service the implement.

## Serial Number

For quick reference and prompt service, record model and serial number on the inside cover page and again on the warranty page. Always provide model number and serial number when ordering parts and in all correspondences with your Land Pride dealer. For location of your serial number plate, see Figure 1.

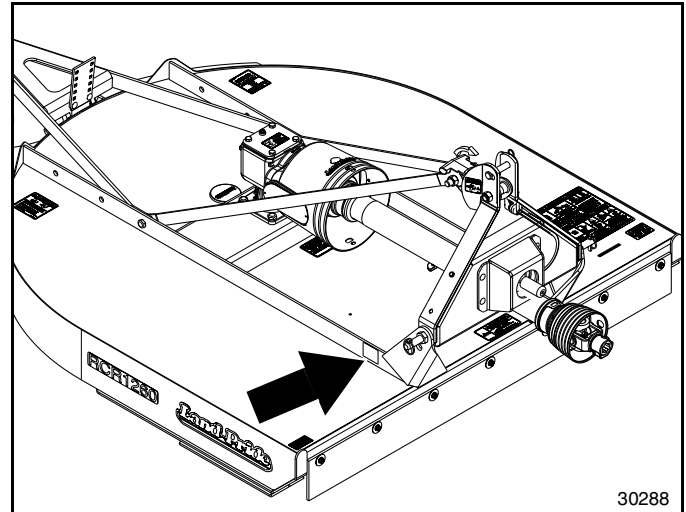

**Serial Number Plate Location  
Figure 1**

## Further Assistance

Your dealer wants you to be satisfied with your new Rotary Cutter. If for any reason you do not understand any part of this manual or are not satisfied with the service received, the following actions are suggested:

1. Discuss any problems you have with your implement with your dealership service personnel so they can address the problem.
2. If you are still not satisfied, seek out the owner or general manager of the dealership, explain the question/problem, and request assistance.
3. For further assistance write to:

**Land Pride Service Department  
1525 East North Street**

P.O. Box 5060  
Salina, Ks. 67402-5060

E-mail address  
[lp servicedept@landpride.com](mailto:lp servicedept@landpride.com)



## Section 1: Assembly & Set-up

### Tractor Requirements

Tractor horsepower should be within the range noted below. Tractors outside the range must not be used.

Horsepower Rating . . . . .	18-60 hp (13-45 kW)
Rear Power Take-Off Shaft Type . . . . .	1 3/8"-6 Spline
Rear Power Take-Off Speed . . . . .	540 rpm
Hitch Type . . . . .	3-point Cat. I QH Ready
Tractor Weight . . . . .	See Important Note Below

### **WARNING**

*To avoid serious injury or death:*

*Lightweight tractors with rear attached implements may need weights added to the front to maintain steering control. Consult your tractor Operator's Manual to determine proper weight requirements and maximum weight limitations.*

### Dealer Preparations

This Rotary Cutter has been partially assembled at the factory. Additional assembly will be required before attaching it to the customer's tractor. Make sure the intended tractor conforms to the requirements above. Read and understand this manual before assembling the cutter. An understanding of how this unit works will aid in the assembly and setup.

### **WARNING**

*To avoid serious injury or death:*

*Always secure cutter with an overhead crane, fork lift, or other suitable lifting device before removing hardware bags, shipping components, bands, lag screws, or hitch pins. The cutter can suddenly fall.*

**IMPORTANT:** Be sure to retain all required hardware and loose components for Assembly and Set-up.

1. Attach a lifting hoist or other device to the tailwheel A-frame or another suitable location to keep deck secured in the vertical position while detaching it from the shipping crate.
2. Before removing the hardware securing the cutter deck to the shipping crate, remove the hardware bag and other loose components zip tied to the deck.
3. Remove hardware securing the cutter deck to the shipping crate. Hardware securing the deck to the shipping crate will not be reused on the cutter.
4. Store all removed components in a safe location where they can be easily retrieved as needed.
5. If preferred, the front shield may be assembled before lowering the deck onto the ground. Refer to "**Front Rubber Deflector Assembly**" on page 14.
6. Carefully lower the deck onto the ground while making sure bystanders and animals are away from the designated deck falling/resting area.
7. Refer to "**Torque Values Chart for Common Bolt Sizes**" on page 40 to determine the correct torque value when tighten hardware during assembly.

### Hitch & Tailwheel Assembly

**Refer to Figure 1-1 on page 13:**

**NOTE:** Snap ring (#12) is normally stored on clevis pin (#10). The snap ring may also be shipped stored in the shipping bag. It is used with "**Driveline Installation**" on page 15.

1. Remove clevis pin (#10) and any loose hardware stored on the clevis pin. Store removed hardware in a safe location for reuse.
2. Reattach clevis pin (#10) to its original location with hairpin cotter (#11).

**IMPORTANT:** Hitch pins (#1) are shipped with a lock washer (#7), nut (#8) and jam nut (#3). If the jam nut is not included, the hitch pin will have a raised boss in its location.

The length of the hitch pin with jam nut (#3) can be adjusted to operator preference. Make certain there are two or more threads showing beyond the jam nut after hex nut (#8) is torqued tight.

3. If included, screw jam nuts (#3) onto hitch pins (#1) until 2" (4 cm) of threads are visible between the jam nut and the threaded end.
4. Attach 3-point hitch frame (#4) as follows:
  - a. If attaching cutter to a 3-point **Cat. I hitch**, install 3-point hitch frame (#4) to the upper hitch pin holes "A1" with hitch pins (#1), bushings (#5), flat washers (#6), lock washers (#7), and nuts (#8).
  - b. **See Important Note in Figure 1-1 on page 13:** If the tractor is too small to lift the cutter high enough to transport, attach the 3-point hitch frame (#4) to the lower hitch pin holes "A2" with hitch pins (#1), bushings (#5), flat washers (#6), lock washers (#7), and nuts (#8).
5. Tighten nuts (#8) to the correct torque.
6. Insert 7/16" linchpins (#2) in hitch pins (#1). (Customer supplies linchpins (#2)).
7. The tailwheel frame (#24) is shipped packaged differently depending on the cutter model number:

**Model RCR1272**

- a. Attach front end of tailwheel frame (#24) to the deck as shown with 5/8"-11 x 1 3/4" GR5 bolts (#18). Do not install flange locknuts (#17) at this time.
- b. Attach back end of A-frame (#24) as shown to adjusting plate (#19) with 3/8"-16 x 1 1/4" GR5 carriage bolts (#26) and hex whiz nuts (#25). Tighten hex whiz nuts to the correct torque.

**Models RCR1242, RCR1248, or RCR1260**

- a. Remove flange locknuts (#17). Do not remove bolts (#18).

## Section 1: Assembly & Set-up

- Attach rear brace bars (#16) inside of tailwheel frame (#24) with 5/8"-11 x 1 3/4" GR5 bolts (#18) and secure with flange locknuts (#17). Draw locknuts up snug and then back off 1/4 turn.

**IMPORTANT:** See Detail A in Figure 1-1. Floating hitch (#13) must be installed with ears (#14) above rear brace bars (#16).

- Refer to Detail A:** Rotate 3-point hitch frame (#4) and the left-side rear brace bar (#16) up as follows:

**NOTE:** The RCR12 Series Rotary Cutters do not require the use or hole "B3" in rear brace bars (#16).

- If attaching the cutter to a 3-point **Cat. I** hitch, align hole "B1" in the left-side rear brace bar (#16) with hole in floating hitch (#13).
  - If tractor is too small to lift cutter high enough for transporting, align hole "B2" in the left-side rear brace bar (#16) with hole in floating hitch (#13).
- Insert 3/4"-10 x 4" GR5 bolt (#9) into the left-side rear brace bar (#16), floating top hitch (#13), and right-side rear brace bar (#16).

- Secure bolt (#9) with hex flange locknut (#15A). Draw locknut up snug and then back off 1/4 turn.
- Install machine washer (#23) on spindle (#21).

**NOTE:** You may need to lift the cutter rear or remove bolts (#26) to assemble tail wheel (#20).

- Insert spindle (#21) in tailwheel frame (#24).
- Install 1" thick spacer (#27) on spindle (#21).
- If tailwheel yoke (#20) is curved (not flat as shown), add second 1/2" thick spacer (#28) to spindle (#21). Otherwise, store the spacer. It may be needed should the gauge wheel assembly need replacing.
- Insert roll pin (#22) in spindle (#21) above spacer (#27) or spacer (#28) if included.

**NOTE:** After hitch and tailwheel assembly, push on hitch frame (#4). It should rotate backward and floating top link (#13) should rotate up. If they do not rotate easily, loosen nuts (#15A) and/or (#15B) until the top link will rotate easily.

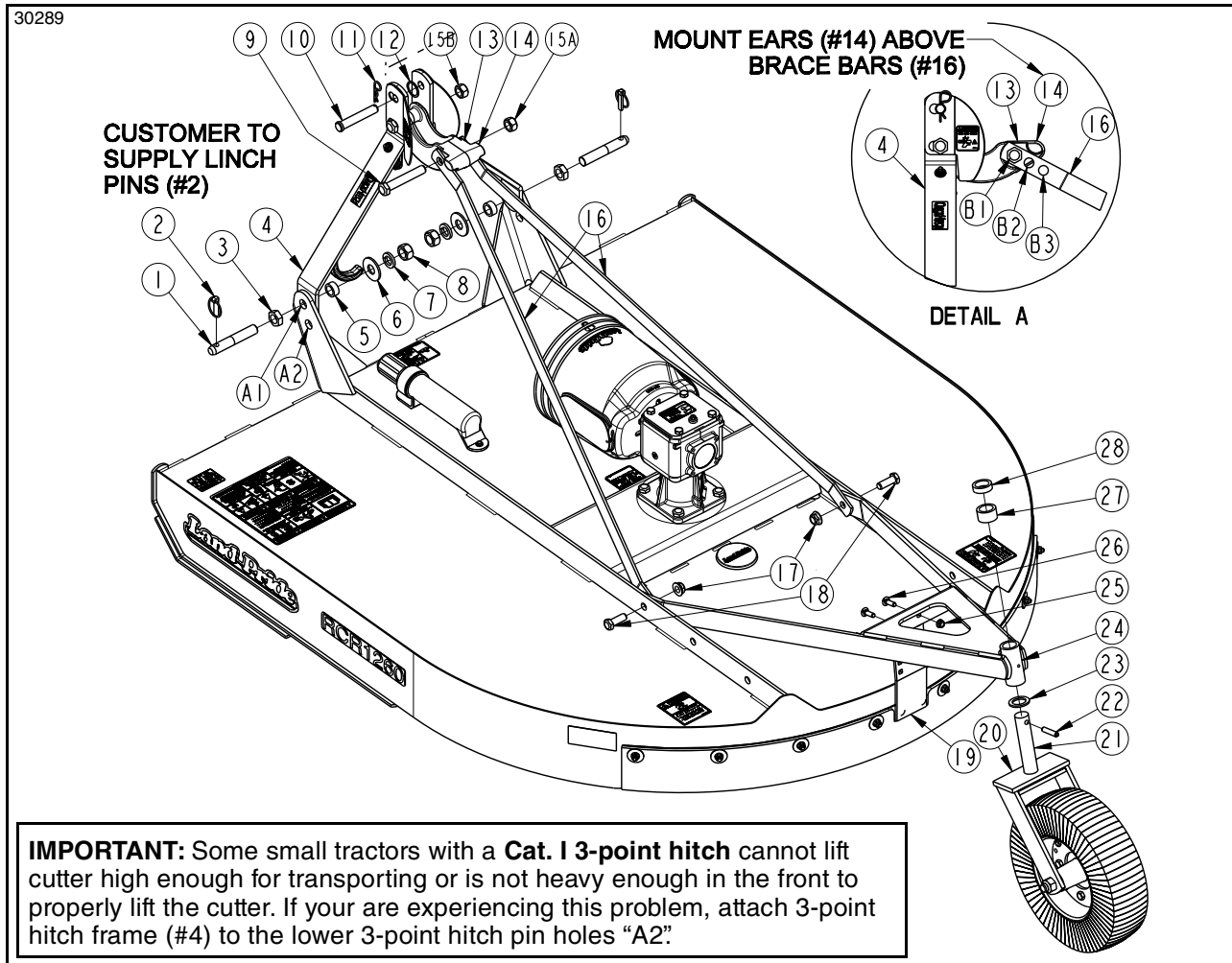

Hitch & Tailwheel Assembly  
Figure 1-1



## Section 1: Assembly & Set-up

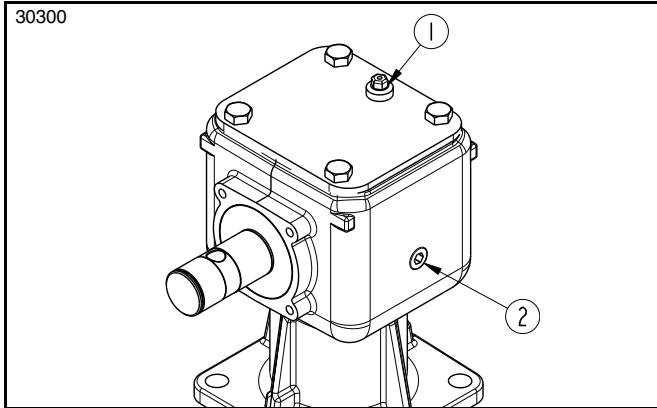

**Gearbox With Vented Plug**  
Figure 1-6

### Gearbox Vented Plug

Refer to Figure 1-6:

**IMPORTANT:** The gearbox is shipped with a solid plug on top to prevent oil loss during shipping and handling. The solid plug must be replaced with a vented plug (#1) before operating the implement.

A vented plug is shipped loose and packaged with the Operator's Manual. Remove temporary solid plug from top of gearbox and replace with the vented plug (#1). See you nearest Land Pride dealer if vented plug is missing.

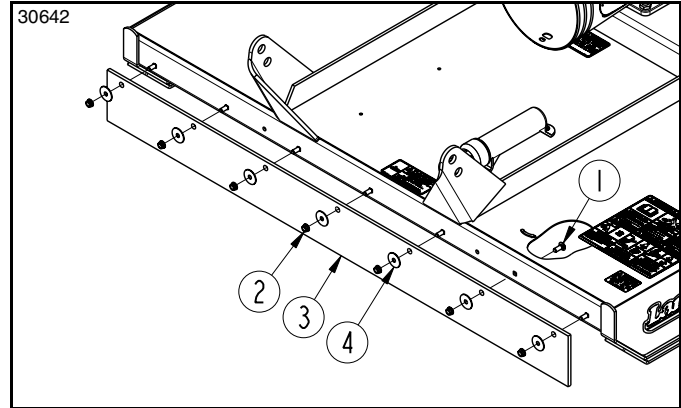

**Front Rubber Guard Assembly**  
Figure 1-2

### Front Rubber Deflector Assembly

Refer to Figure 1-2:

1. Attach front rubber deflector (#3) to the deck as shown with 3/8"-16 x 1" GR5 carriage bolts (#1), fender washers (#4), and hex whiz nuts (#2).
2. Tighten whiz nuts (#2) to the correct torque after all front rubber deflector hardware has been installed.

**NOTE:** Rear rubber deflector not required on RCR1242 cutter.

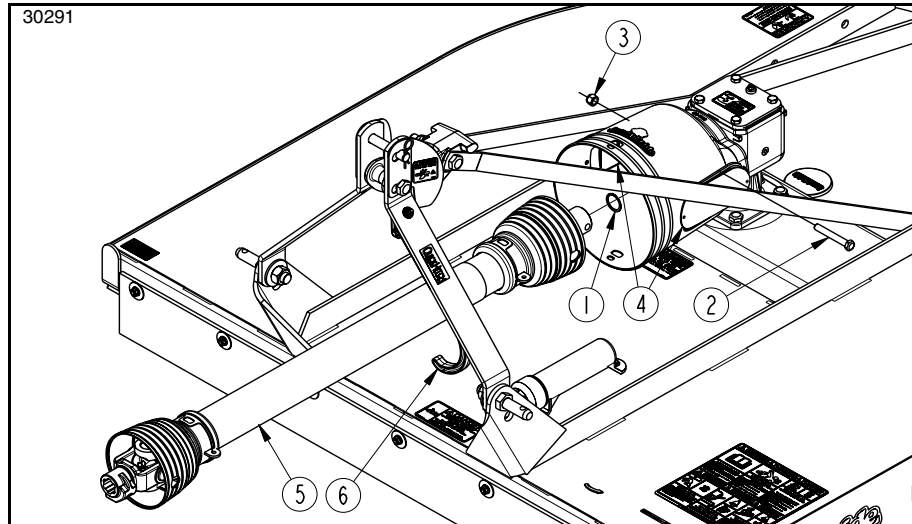

Driveline Installation (Shear Bolt Driveline Shown)  
Figure 1-3

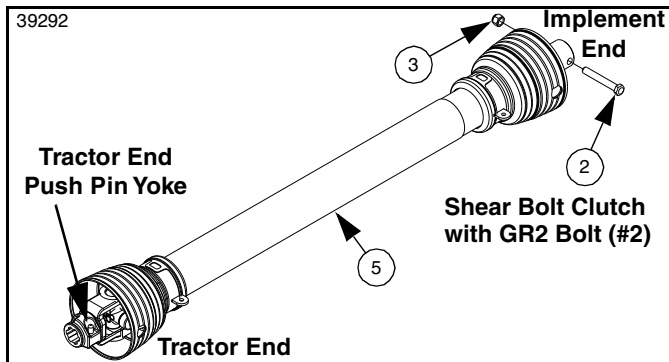

Driveline With Shear Bolt Clutch  
Figure 1-4

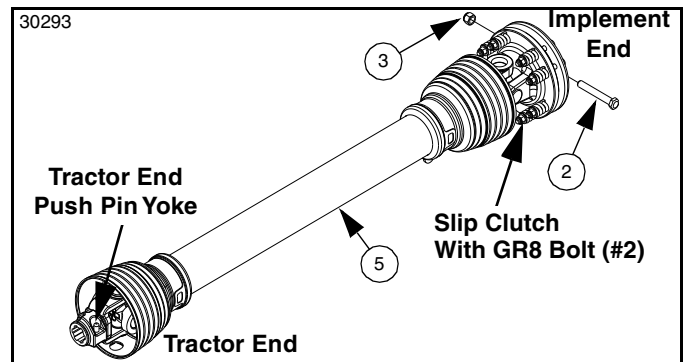

Driveline With Slip Clutch  
Figure 1-5

## Driveline Installation

Refer to Figures 1-3, 1-4, & 1-5

The driveline is coupled to the tractor's power take-off shaft with a push pin yoke and to the implement with either a shear bolt or bolt on slip clutch to protect from shock loads.

**IMPORTANT:** The driveline must be lubricated before putting it into service. Refer to "Lubrication Points" on page 34.

Refer to Figure 1-3:

1. Unsnap side access covers (#4) from both sides of the gearbox shield. Save covers for reuse.
2. Lubricate the gearbox input shaft. Refer to "Gearbox Input Shaft" on page 34.
3. Remove bolt (#2) from end of driveline (#5).
4. Slide driveline (#5) onto the gearbox input shaft until holes in the driveline yoke align with the hole in the gearbox input shaft.

5. Insert bolt (#2) through driveline yoke and gearbox input shaft.
6. Secure bolt with removed nylock nut (#3). Tighten hex nut to the correct torque.
7. Skip to step #9 if installing a slip clutch driveline.

**NOTE:** Snap ring (#1) is for extra security should shear bolt (#2) break. Do not use the snap ring with a slip clutch driveline.

8. If driveline (#5) has a shear bolt instead of a slip clutch, then install snap ring (#1) on the groove located on the end of the input shaft. Discard snap ring if the driveline has a slip clutch.
9. Reinstall access covers (#4).
10. Raise driveline (#5) up and rotate driveline hook (#6) down.
11. Lower driveline (#5) until it is resting in driveline hook (#6).
12. Continue with "3-Point Hook-Up" on page 16.

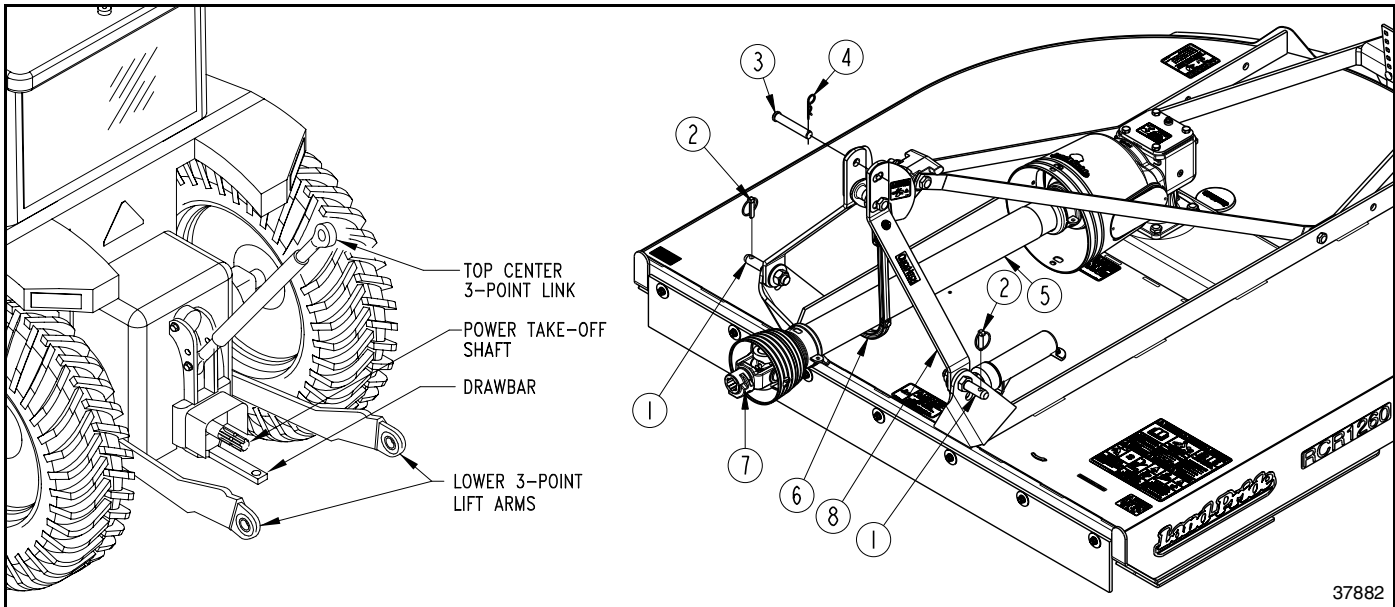

**Tractor Hook-Up**  
**Figure 1-7**

### 3-Point Hook-Up

Refer to Figure 1-7:

#### **DANGER**

To avoid serious injury or death:

A crushing hazard exists while hooking-up and unhooking the implement. Keep people and animals away while backing-up to the implement or pulling away from the implement. Do not operate hydraulic controls while a person or animal is directly behind the power machine or near the implement.

**NOTE:** Land Pride's Quick Hitch can be attached to the tractor to provide quick and easy 3-point hook-up and detachment. See your nearest Land Pride dealer to purchase a Quick-Hitch.

1. Slowly back tractor up to Rotary Cutter while using tractor's 3-point hydraulic control lever to align lower 3-point lift arms holes with cutter hitch pins (#1).
2. Engage tractor park brake, shut tractor engine off, and remove key before dismounting from tractor.
3. Slide lower 3-point lift arms onto cutter hitch pins (#1). Install linchpins (#2) through hitch pin holes to lock lower 3-point arms into position. Linchpins are supplied by customer.
4. Connect top center 3-point link to upper hitch pin holes using factory supplied 3/4" clevis pin (#3). Secure clevis pin with hairpin cotter (#4).
5. Ensure tractor lower hitch arms are blocked to prevent excessive side movement.

6. Return to tractor and slowly raise and lower implement carefully to ensure drawbar, tires, and other equipment on the tractor do not make contact with cutter frame and driveline. Move or remove drawbar if needed.
7. Manually adjust one of the two lower 3-point lift arms up or down to level the Rotary Cutter from left to right. Final adjustments will be made later during "**Deck Leveling & Cutting Height**" on page 21.
8. The arm lift rods on your tractor's 3-point lift arms should be adjusted to allow for lateral float. Please consult your tractor's manual for adjusting instructions.



## Section 1: Assembly &amp; Set-up

## Driveline Hook-Up

Refer to Figure 1-7 on page 16:

### DANGER

To avoid serious injury or death:

- Tractor power take-off shaft shield, driveline shields, and gearbox shaft shields must be installed and in good working condition to avoid driveline entanglement and projectiles flying off of the driveline.
- Do not engage power take-off while hooking-up or unhooking the driveline, or while someone is standing near the driveline. A person's body and/or clothing can become entangled in the driveline.
- Do not use a power take-off adapter. The adapter will increase strain on the tractor's power take-off shaft causing possible damage to shaft and driveline. It will also defeat the purpose of the tractor's power take-off shield.
- Make certain driveline yokes are securely fastened at each end. A loose yoke can work free allowing the driveline to rotate uncontrollably.
- All guards and shields must be installed and in good working condition while operating the implement.

### WARNING

To avoid serious injury or death:

- Always follow "Tractor Shutdown Procedure" provided in this manual before dismounting the tractor.
- Check driveline when lowering implement to make sure it does not interfere with the tractor drawbar at maximum depth. If needed, shut tractor off and move or remove drawbar to prevent driveline damage.

**IMPORTANT:** An additional driveline may be required if implement is attached to more than one tractor or if a Quick Hitch is used.

**IMPORTANT:** Drivelines with friction clutches must go through a "run-in" prior to initial use and after long periods of inactivity. For detailed instructions, see "Driveline with Slip Clutch" on page 31.

**IMPORTANT:** Check driveline minimum collapsible length before completing "Driveline Hook-Up". Structural damage to the tractor and implement can occur if this check is not made. Refer to "Check Driveline Collapsible Length" on page 18.

1. If driveline collapsible length has not been checked, go to "Check Driveline Collapsible Length" on page 18. Otherwise, continue with step 2 below.
2. Park tractor and implement on a level surface.
3. Shut tractor down before dismounting. Refer to "Tractor Shutdown Procedure" on page 25.
4. If tractor drawbar interferes with the driveline during hook-up, disconnect driveline and move drawbar forward, to the side, or remove.
5. Remove driveline (#5) from driveline support (#6). Driveline support is spring loaded and will rotate up against A-frame (#8).
6. Collapse driveline (#5) by pushing tractor end of driveline toward the cutter gearbox.
7. Push in on push pin (#7) and slide outer driveline universal joint over tractor power take-off shaft.
8. Release push pin (#7) and continue to slide universal joint over tractor power take-off shaft until push pin releases and pops up.
9. Pull on driveline yokes at the tractor and implement end to make sure they are secured to the tractor power take-off shaft and implement gearbox shaft.
10. The tractor's lower 3-point arms should be adjusted for lateral float. Please consult your tractor's manual.
11. Continue with "Check Driveline Interference" on page 19.

## Section 1: Assembly & Set-up

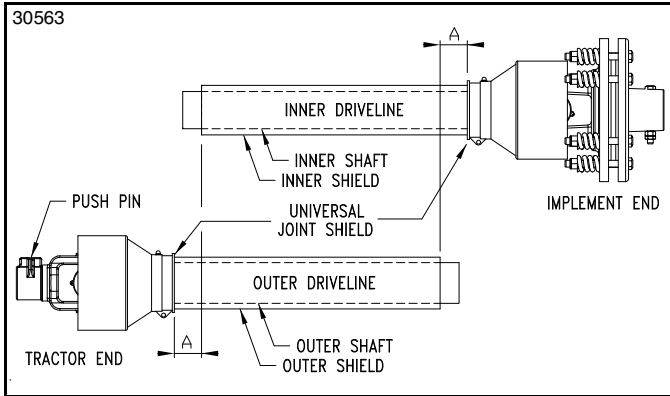

**Driveline Shortening**  
**Figure 1-8**

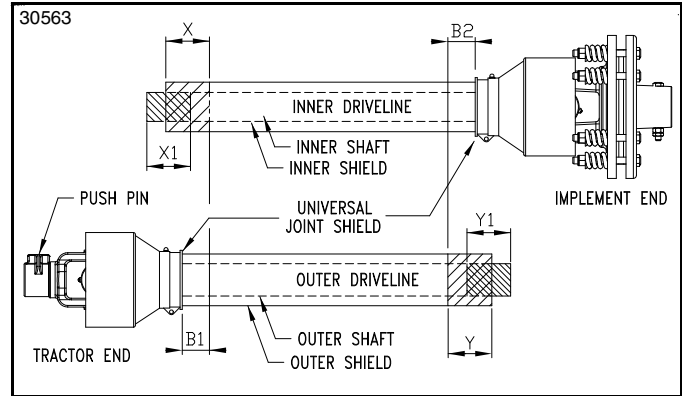

**Driveline Shortening**  
**Figure 1-9**

### Check Driveline Collapsible Length

**IMPORTANT:** A driveline that is too long can bottom out causing structural damage to the tractor and implement. Always check driveline minimum length during initial setup, when connecting to a different tractor, and when alternating between using a quick hitch and a standard 3-point hitch. More than one driveline may be required to fit all applications.

**IMPORTANT:** The power take-off shaft and gearbox input shaft must be aligned and level with each other when checking driveline minimum length. A driveline that is too long can damage tractor and implement.

1. With driveline attached only to the 3-point implement, remove outer driveline (tractor end) from inner driveline to separate the two profiles.
2. Park tractor and implement on a level surface.
3. Raise implement until the gearbox input shaft is level and in-line with the tractor power take-off shaft.
4. Securely block implement at this height to keep unit from lowering.
5. With implement resting on the support blocks, Shut tractor down according to "**Tractor Shutdown Procedure**" on page 25.
6. Attach outer driveline to the tractor's power take-off shaft. Refer to steps 5-9 under "**Driveline Hook-Up**" on page 17.

#### Refer to Figure 1-8:

7. Hold inner and outer drivelines parallel to each other as shown and measure distance "A".
  - If "A" is less than 1" (2.5 cm), continue with step 8.
  - If "A" is greater than or equal to 1" (2.5cm), skip to "**Reassemble Driveline**" on page 18.

#### Refer to Figure 1-9:

8. If dimension "A" was less than 1" (2.5 cm), shorten driveline as follows:
  - a. Measure 1" (2.5 cm) ("**B1**" dimension) back from outer driveline shield and make a mark at this location on the inner driveline shield.
  - b. Measure 1" (2.5 cm) ("**B2**" dimension) back from the inner driveline shield and make a mark at this location on the outer driveline shield.
9. Remove outer driveline from the tractor power take-off shaft and inner driveline from the implement's gearbox shaft.
10. Cut off non-yoke end of inner driveline as follows:
  - a. Measure from end of inner shield to scribed mark ("**X**" dimension) and record.
  - b. Cut off inner shield at the mark. Cut same amount off the inner shaft ("**X1**" dimension).
11. Cut off non-yoke end of outer driveline as follows:
  - a. Measure from end of outer shield to scribed mark ("**Y**" dimension) and record.
  - b. Cut off outer shield at the mark. Cut same amount off the outer shaft ("**Y1**" dimension).
12. Remove all burrs and cuttings.
13. Continue with "**Reassemble Driveline**" below.

### Reassemble Driveline

#### Refer to Figure 1-9:

1. Apply multi-purpose grease to the inside of the outer shaft and reassemble the driveline.
2. Reattach driveline to tractor power take-off shaft and gearbox shaft. Refer to "**Driveline Installation**" on page 15 and "**Driveline Hook-Up**" on page 17.
3. Continue with "**Check Driveline Interference**" on page 19.

## Section 1: Assembly & Set-up

### Check Driveline Interference

Refer to Figure 1-10:

#### **WARNING**

To avoid serious injury or death:

A rotating driveline must not exceed an angle of 25 degrees up or down, and never engage a driveline while at an angle exceeding 25 degrees up or down. The driveline can break and send flying projectiles.

1. Start tractor and raise implement slightly off the support blocks used to “**Check Driveline Collapsible Length**”. Drive forward until the implement is clear of the support blocks.
2. Slowly and carefully lower and raise the implement to ensure drawbar, tires, and other equipment on the tractor do not contact the implement’s frame. If there is an interference:
  - a. Back implement over the support blocks and lower it onto the blocks.
  - b. Shut tractor down before dismounting. Refer to “**Tractor Shutdown Procedure**” on page 25
  - c. Move or remove drawbar if it interferes with the implement and make any other necessary corrections.
  - d. Repeat steps 1-2 to verify the implement does not interfere with the tractor.
3. Start tractor, raise implement fully up. Back implement over the support blocks. Do not lower implement onto the support blocks.
4. Without changing the 3-point lift height, shut tractor down using “**Tractor Shutdown Procedure**” on page 25.
5. Check to make sure driveline does not exceed 25° above horizontal.
6. Start tractor, raise implement slightly, and drive forward enough to clear the support blocks.
7. Lower implement to ground and shut tractor down using “**Tractor Shutdown Procedure**” on page 25.

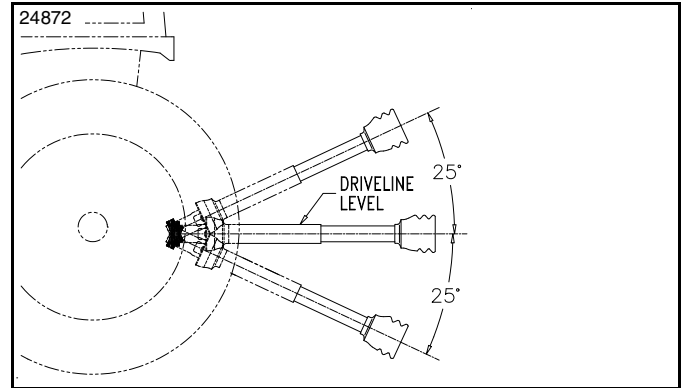

**Maximum Driveline Movement During Operation**  
Figure 1-10

Section 2: Accessories

**Replaceable Skid Shoes (Accessory)  
For RCR1260 & RCR1272 Cutters**

Refer to Figure 2-1:

**WARNING**

To avoid serious injury or death:

Excessive wear on skid shoes can damage side panels, cause inadequate operation of cutter, and create a safety hazard. Always replace skid shoes at the first sign of wearing thin.

Replaceable skid shoes may be purchased for the RCR1260 and RCR1272 to extend the wear life of the cutter built in skids. See your nearest Land Pride dealer to order skid shoes.

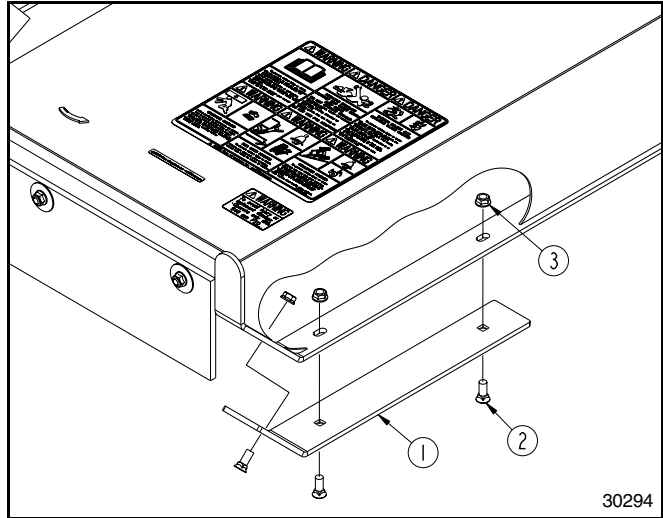

**Skid Shoe Replacement  
Figure 2-1**

RCR1260 & RCR1272 Skid Shoes		
#	Part No.	Part Description
	326-120A	SKID SHOE KIT (Consist 2 skid shoes, 6 plow bolts and 6 locknuts.)
1	326-221D	SKID SHOE
2	802-603C	PLOW BOLT 3/8-16 x 1" GR5
3	803-198C	NUT HEX WHIZ 3/8-16 PLT

1. Attach skid shoes (#1) to the cutter's side panels with 3/8" plow bolts (#2) and 3/8" hex flange locknuts (#3) as shown in Figure 2-1. Tighten locknuts to the correct torque.
2. Once installed, check skid shoes and plow bolts for wear frequently and replace as needed.

Section 3: Adjustments

### Deck Leveling & Cutting Height

There are 4 primary adjustments that should be made prior to actual field operations:

- Deck Leveling Left to Right
- Cutting Height Adjustment
- Center 3-Point Link Adjustment
- Tailwheel Height Adjustment

Proper adjustment of each of these items will provide for higher efficiency, improved cutting performance, and longer blade life. The following tools will be needed:

- Pliable tape measure
- Spirit or carpenters level
- Open end or hex end wrench or socket set
- Protective gloves

#### **WARNING**

To avoid serious injury or death:

Always disengage power take-off, put tractor in park or set park brake, shut tractor engine off, remove ignition key, and wait for blades to come to a complete stop before dismounting tractor.

#### Deck Leveling Left to Right

Figure 3-1:

1. Locate tractor with Rotary Cutter on a flat, level surface.
2. Use tractor's hydraulic 3-point control lever to lower cutter until the tailwheel makes contact with the ground surface.
3. Place a level on the front of the cutter deck as shown in Figure 3-1. Manually adjust either one or both of the tractor's lower 3-point arms to level the deck from left to right. Some tractors have only a single adjusting arm.

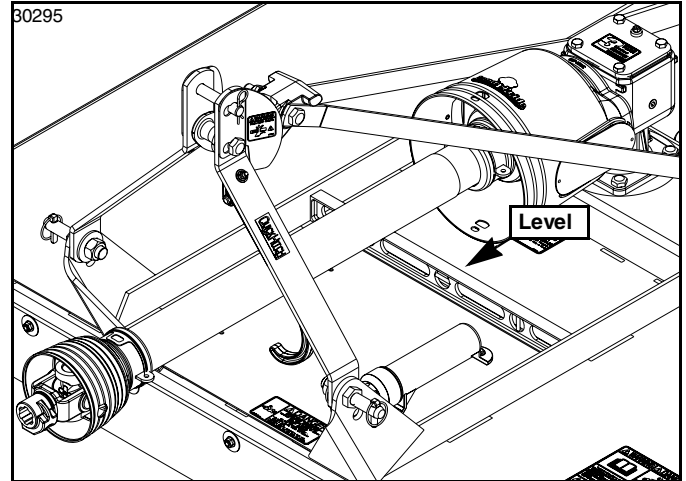

Deck Leveling  
Figure 3-1

#### Cutting Height Adjustment

Figure 3-2:

#### **WARNING**

To avoid serious injury or death:

Avoid direct contact with cutter blades by wearing a pair of gloves. Cutter blades have sharp edges and burrs that can cause injuries.

**IMPORTANT:** The front blade tip should be slightly lower than the rear blade tip (about 1" or 2.5 cm lower). If not, the cutter is subject to continuous material flow under it's deck causing horsepower loss, grass clumps, blade wear, and frequent blade sharpening.

1. Using tractor's 3-point hydraulic control, raise or lower the 3-point arms until the front of the deck is slightly lower than the rear of the deck.

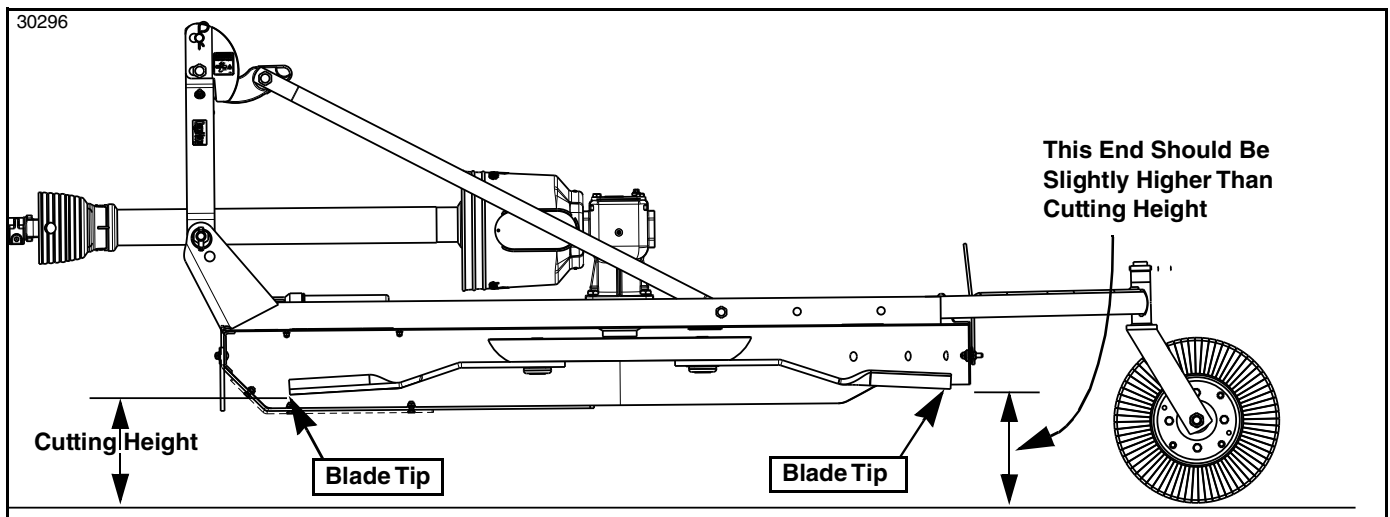

Cutting Height  
Figure 3-2

## Section 3: Adjustments

- The top center link typically is adjusted with the upper clevis pin vertically above lower hitch pins, as shown in Figure 3-3.
- With gloves on, carefully rotate each blade tip to the position shown in Figure 3-2 on page 21.
- Measure distance from cutting tip of blade to ground surface. This distance is the cutting height.
- If desired cutting height cannot be obtained by adjusting the lower 3-point arms, then readjust tailwheel height. See “**Tailwheel Height Adjustment**” on this page.
- Repeat steps 1 to 5 until desired cutting height is achieved.
- Set tractor’s 3-point hydraulic control stop at this height.

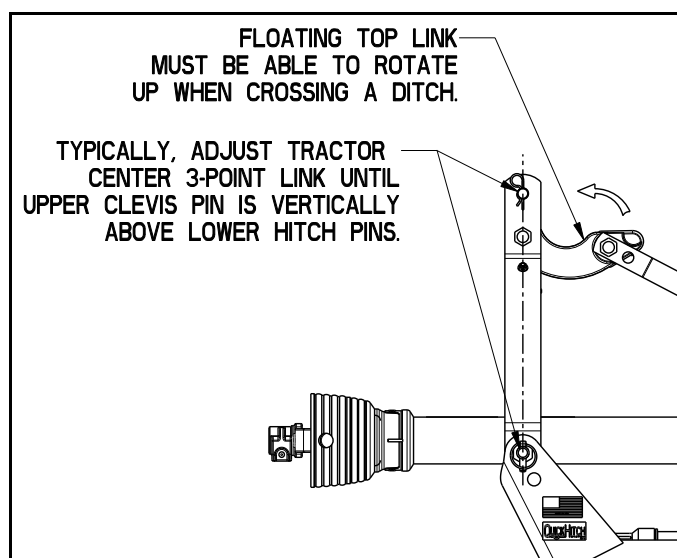

**Center 3-Point Link Adjustment**  
Figure 3-3

### Center 3-Point Link Adjustment

Refer to Figure 3-3:

- Lower cutter deck to the nominal cutting height.

**NOTE:** Customer may adjust center 3-point link to his or her preference. Lengthening center 3-point link allows more movement while going over raised surfaces. Shortening the link allows more movement while crossing over ditches. Also, shortening center link allows the cutter to be carried higher while traveling. Never length center link to where the cutter is carried too low.

- Typically the center 3-point link is adjusted so that the upper 3-point clevis pin is straight above the lower 3-point hitch pins. This arrangement allows for optimum ground contour following performance.
- Lock center link in this position once correct length is achieved. Adjustment on center 3-point link can be made depending on customer’s preference.

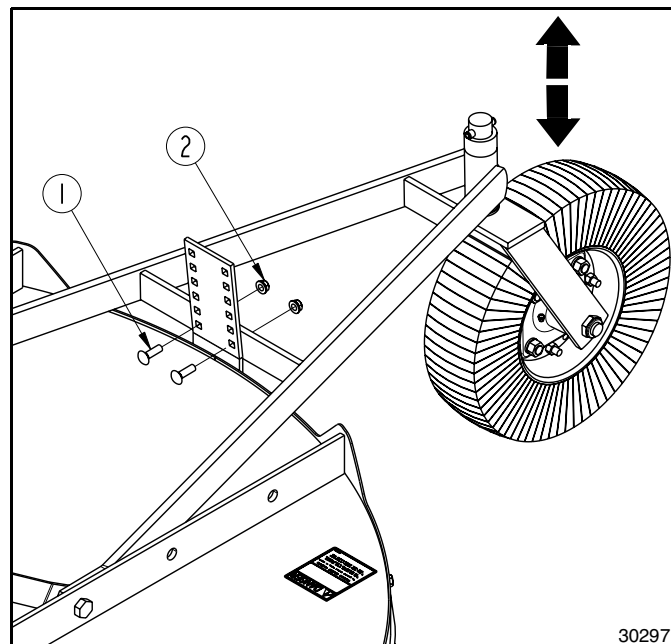

**Tailwheel Height Adjustment**  
Figure 3-4

### Tailwheel Height Adjustment

Refer to Figure 3-4:

The deck slope should be adjusted so that the cutting blades are slightly lower at the front of the cutter than at the back. If they are not, the tailwheel must be adjusted up or down until the deck slope is correct.

- Make sure instructions for setting the “**Cutting Height Adjustment**” have been followed before continuing with adjusting tailwheel height below.
- Use tractor’s 3-point hydraulic control to lift tailwheel off the ground.
- Remove 3/8" carriage bolts (#1) and flange nuts (#2).
- Adjust tailwheel as follows:
  - To lower blade height at the rear, raise tailwheel.
  - To raise blade height at the rear, lower tailwheel.
- With tailwheel adjusted to the correct position, replace 3/8" carriage bolts (#1) and whiz nuts (#2). Draw whiz nuts up snug, do not tighten until after rechecking deck cutting height.
- Recheck deck cutting height. Refer to instructions for adjusting the “**Cutting Height Adjustment**” on page 21.
- After the deck cutting height and tailwheel height are adjusted correctly, tighten whiz nuts (#2) shown in Figure 3-4 below to the correct torque.





Section 4: Operating Procedures

**Operating Checklist**

Hazard control and accident prevention are dependent upon the awareness, concern, prudence and proper training involved in the operation, transport, storage, and maintenance of the Rotary Cutter. Therefore, it is absolutely essential that no one operates the cutter unless they have read, fully understood, and are totally familiar with the Operator's Manual. Make sure the operator has paid particular attention to:

- **Important Safety Information**, page 1
- **Section 1: Assembly & Set-up**, page 12
- **Section 2: Accessories**, page 20
- **Section 3: Adjustments**, page 21
- **Section 4: Operating Procedures**, page 23
- **Section 5: Maintenance & Lubrication**, page 28

Perform the following inspections before using your Rotary Cutter.

**Operating Checklist**

✓	Check	Page
	Make sure all guards and shields are in place. Refer to "Important Safety Information".	1
	Read & follow hook-up & preparation instructions. Refer to "Section 1: Assembly & Set-up".	16
	Read and make all required adjustments. Refer to "Section 3: Adjustments".	21
	Lubricate cutter and driveline as needed. Refer to "Lubrication Points".	34
	Make sure all gearboxes are properly lubricated and that all oil plugs have been replaced properly. Refer to Gearbox lubrication.	35
	Check cutter initially and periodically for loose bolts and pins. Refer to "Torque Values Chart".	40

**Inspection of Tractor & Cutter**

Make the following inspections with cutter attached to a tractor, power take-off disengaged, and cutter blades stopped.

1. Park tractor and cutter on a level surface.
2. Disengage power take-off, place gear selector in park, set park brake, shut tractor off, and remove switch key. Make sure cutter blades have come to a complete stop before dismounting from tractor.
3. Inspect tractor safety equipment to make sure it is installed and in good working condition.
4. Inspect cutter safety equipment to make sure it is installed and in good working condition.
5. Check driveline to make certain it is securely connected to the tractor power take-off shaft and cutter gearbox shaft.
6. Check driveline guards to make certain they are in good condition and in place.

7. Carefully raise and lower implement to ensure that the drawbar, tires, and other equipment on the tractor do not contact cutter frame or driveline.
8. With cutter resting on solid supports, power take-off disengaged, and blade rotation completely stopped:
  - Check for and remove foreign objects wrapped around blade spindles.
  - Check for nicked, bent, broken, and worn cutting blades. Replace or sharpen blades as required. Refer to "**Cutter Blade Maintenance**" on page 28.
9. Remove solid supports from under the deck.
10. Verify cutter is set at the correct cutting height. See "**Deck Leveling & Cutting Height**" on page 21.

The remaining inspections are made by engaging the power take-off to check for vibrations.

**WARNING**

To avoid serious injury or death:

- Stop power take-off immediately if vibration continues after a few revolutions during start-up and anytime thereafter. Wait for all components to come to a complete stop before dismounting from tractor to check for probable causes. Make necessary repairs and adjustments before continuing.
  - Some tractors are equipped with two power take-off speeds. Be certain your tractor's power take-off shaft is set-up to operate at 540 rpm. Do not exceed 540 rpm power take-off speed. Excessive speed can damage drive/driven components and increase the risk of a thrown object hazard.
11. Start tractor, set throttle to idle or slightly above idle, and slowly engage power take-off. Initial start-up vibration is normal and should stop after a few revolutions. Stop power take-off rotation immediately if vibration continues.
  12. Once the cutter is running smoothly, increase tractor power take-off speed to 540 rpm. Stop power take-off rotation immediately if vibration occurs.
  13. Investigate cause of vibration and make repairs before putting cutter back into service.

## Section 4: Operating Procedures

## Safety Information

 **DANGER**

To avoid serious injury or death:

- Never place hands or feet under the deck or attempt to make adjustments to the cutter with power take-off engaged. Cutter blades rotating at high speeds cannot be seen and are located close to the deck sides. Body extremities will be cut off instantly.
- Do not engage power take-off while hooking-up or unhooking the driveline, or while someone is standing near the driveline. A person's body and/or clothing can become entangled in the driveline.
- Do not use a power take-off adapter. The adapter will increase strain on the tractor's power take-off shaft causing possible damage to shaft and driveline. It will also defeat the purpose of the tractor's power take-off shield.
- Clear area to be cut of debris and other unforeseen removable objects before cutting. Mark non-removable hazards such as tree stumps, post stubs, protruding objects, rocks, drop-offs, holes, etc. with a visible flag.
- Rotary Cutters have the ability to discharge objects at high speeds; therefore, the use of front & rear safety guards is mandatory with this cutter. Stop blade rotation if bystanders are in or around the area. It is recommended that a safety shield be placed between the operator and cutter on an open air tractor.
- All guards and shields must be installed and in good working condition while operating the implement.
- Tractor power take-off shaft shield, driveline shields, and gearbox shaft shields must be installed and in good working condition to avoid driveline entanglement and projectiles flying off of the driveline.
- Always disconnect the driveline from the power take-off shaft before servicing underside of cutter. The tractor can be started with the power take-off engaged.
- Do not use cutter as a fan. Cutting blades are not properly designed or guarded for this use.

 **WARNING**

To avoid serious injury or death:

- Allow only persons to operate this implement who have fully read and comprehended this manual, and who have been properly trained in the safe operation of this implement. Serious injury or death can result from the inability to read, understand, and follow instructions provided in this manual.
- Do not operate and/or travel across inclines where the tractor and/or implement can rollover. Consult your tractor's manual for acceptable inclines the tractor is capable of traveling across.

- Never carry riders on the implement or power machine. Riders can obstruct the operator's view, interfere with controls, be pinched by moving components, become entangled in rotating components, struck by objects, thrown about, fall off and be run over, etc.
- A rotating driveline must not exceed an angle of 25 degrees up or down, and never engage a driveline while at an angle exceeding 25 degrees up or down. The driveline can break and send flying projectiles.
- Do not operate a broken or bent driveline. Such a driveline will break apart while rotating at high speeds. Always remove the implement from use until the damaged driveline can be repaired or replaced.
- Always follow "Tractor Shutdown Procedure" provided in this manual before dismounting the tractor.
- Always disengage power take-off before lifting cutter fully up. Never operate cutter in the raised position. The cutter can discharge objects at high speeds.
- Do not use implement as a man lift or work platform. It is not properly designed or guarded for this use.
- Perform scheduled maintenance. Check for loose hardware, missing parts, broken parts, structural cracks, and excessive wear. Make repairs before putting the implement back into service.
- Do not use implement to lift objects; to pull objects such as fence posts, stumps, etc; or to push objects. The unit is not designed or guarded for these uses.
- Select a safe ground speed that will allow adequate control of steering and stopping. Never exceed 20 mph (32 km/h) with attached equipment. Rough terrain requires a slower speed.
- Buildup of debris around moving components and gearboxes is a fire hazard. Keep rotating parts and gearboxes free from debris.
- Improper oil level can cause bearing failure and be a fire hazard. Maintain proper gearbox oil level.
- Do not exceed rated cutting capacity of your cutter. See specifications & capacities for specified cutting capacity. Exceeding rated cutting capacity can damage drive components, cutter blades, and deck components.
- Some tractors are equipped with two power take-off speeds. Be certain your tractor's power take-off shaft is set-up to operate at 540 rpm. Do not exceed 540 rpm power take-off speed. Excessive speed can damage drive/driven components and increase the risk of a thrown object hazard.



## Section 4: Operating Procedures

### Tractor Shutdown Procedure

The following are basic tractor shutdown procedures. Follow these procedures and any additional shutdown procedures provided in your tractor Operator's Manual before leaving the operator's seat.

1. Reduce engine speed and disengage power take-off if engaged.
2. Park tractor and implement on level, solid ground.
3. Lower implement to ground or onto non-concrete support blocks.
4. Put tractor in park or set park brake, turn off engine, and remove switch key to prevent unauthorized starting.
5. Relieve all hydraulic pressure to auxiliary hydraulic lines.
6. Wait for all components to come to a complete stop before leaving the operator's seat.
7. Use steps, grab-handles and anti-slip surfaces when stepping on and off the tractor.

### Transporting



#### WARNING

To avoid serious injury or death:

- *When traveling on roadways, travel in such a way that other vehicles may pass you safely. Always use LED lights, clean reflectors, and a slow moving vehicle sign that is visible from the back to warn operators in other vehicles of your presence. Always comply with all federal, state, and local laws.*
  - *Always disengage power take-off and wait for the driveline to stop rotating before raising the implement to the transport position.*
1. Make sure driveline does not contact tractor or cutter when raising cutter to transport position.
  2. Reduce tractor ground speed when turning and leave enough clearance so cutter does not contact obstacles such as buildings, trees, or fences.
  3. Limit transport speed to 20 mph. Transport only with a farm tractor of sufficient size and horsepower.
  4. When traveling on roadways, transport in such a way that faster moving vehicles may pass you safely.
  5. Shift tractor to a lower gear when traveling over rough or hilly terrain.

### Blade Engagement & Disengagement

Cutter blades can lock-up against each other during start-up and shut-down especially if the tractor's power take-off engagement is "INSTANT ON" and "INSTANT OFF". Following Blade Engagement and Blade Disengagement instructions below will help eliminate blade lock up.

#### Blade Engagement

1. Increase throttle to a speed just enough to get the cutter started without stalling tractor while slowly engaging drivelines. Use tractor's power take-off soft start option if available.
2. Ensure that all power shafts are rotating and that the cutter is not vibrating excessively after ramping up to power take-off speed for at least 3 seconds. If excessive vibration continues after 3 seconds at full power take-off speed, disengage power take-off immediately, shut down tractor, and remove switch key.
3. Check blades for a lock-up situation. Block cutter deck up before working under the unit. Unlock blades, remove support blocks, and repeat "Blade Engagement" instructions.

#### Blade Disengagement

1. Slowly decrease throttle speed until engine idle speed is reached and then disengage power take-off.
2. Engage tractor park brake, shut tractor engine off and remove switch key. Stay on tractor until blades have come to a complete stop.



## Section 4: Operating Procedures

### Field Operation

#### **DANGER**

To avoid serious injury or death:

Clear area to be cut of debris and other unforeseen removable objects before cutting. Mark non-removable hazards such as tree stumps, post stubs, protruding objects, rocks, drop-offs, holes, etc. with a visible flag.

**IMPORTANT:** Maintain correct power take-off speed. Loss of power take-off speed will allow blades to swing back resulting in ragged, uneven cutting.

**IMPORTANT:** Your cutter is equipped with free swinging cutting blades to reduce shock loads when striking obstacles. However, it is best to avoid striking obstacles to extend cutter and blade life.

**NOTE:** Do not cut in wet conditions. Wet material will build up on the deck underside creating poor discharge, high wear, and additional horsepower.

**NOTE:** Periodically disengage power take-off, turn off tractor, remove key & check for objects wrapped around blade spindle. Block deck up before removing objects.

Frequently inspect cutter for loose bolts and nuts. Tighten all loose hardware as indicated in the “**Torque Values Chart**” on page 40.

1. Thoroughly inspect area to be cut for debris and unforeseen objects. Mark any potential hazards.
2. Follow “**Blade Engagement**” instructions on this page to start cutter blades turning.
3. Optimum ground speed depends on density of material being cut, horsepower rating of tractor, and terrain. Always operate tractor at cutter’s full rated power take-off speed in a gear range that allows the cutter to make a smooth cut without lugging tractor down, usually between 2 to 5 mph.
4. Stop traveling and disengage power take-off after the first 50 feet of cutting. Check cutter levelness and cutting height to make certain it is adjusted properly.
5. Do not engage power take-off with 3-point cutter fully raised.
6. Periodically disengage power take-off, shut down tractor, remove key, and check for foreign objects wrapped around the blade spindle. Block cutter deck up before removing objects.
7. Frequently inspect cutter for loose bolts and nuts. Tighten all loose bolts and nuts as indicated in the “**Torque Values Chart**” on page 40.
8. For additional information, see “**General Operating Instructions**” on page 27.

### Unhook Rotary Cutter

Unhook Rotary Cutter from tractor as follows:

1. See “**Long-Term Storage**” on page 33 if cutter is to be stored for a long time.
2. Park on a level solid surface and lower deck to ground level or onto support blocks.
3. Engage tractor park brake, shut tractor engine off, and remove switch key. Stay on tractor until blades have come to a complete stop.
4. Disconnect driveline and safety chain from tractor.
5. Unhook 3-point hitch from tractor and drive tractor forward several feet.
6. Reinstall hitch pins, linchpins, and hair pin cotters in cutter hitch for safe keeping.
7. Collapse driveline by pushing tractor end of driveline towards cutter gearbox.
8. Support collapsed driveline off the ground by rotating driveline hook holder under driveline and letting driveline rest in J-hook for storage.



## Section 4: Operating Procedures

### General Operating Instructions

It is important that you familiarized yourself with the Operator's Manual, completed Operators Checklist, properly attached cutter to your tractor, made leveling adjustments, and preset your cutting height before beginning a running operational safety check on your Land Pride Rotary Cutter.

The running operational safety check may now be done. It is important that at any time during this safety check you detect a malfunction in either the cutter or tractor that you immediately shut the tractor off, remove it's key, and make necessary repairs and/or adjustments before continuing on.

Make sure before starting the tractor that the park brake is engaged, the power take-off is disengaged, and the cutter is resting on the ground. Start the tractor and set the engine throttle speed at a low idle. Raise the cutter with the tractor's rear hydraulic lift control lever to transport position making sure that the power take-off shaft does not bind and does not contact the cutter frame. Lower the cutter to the ground and at a low engine speed engage the power take-off. If everything is running smoothly at a low idle, slowly raise the cutter to transport height checking for bind or chatter in the driveline. Lower the cutter to the ground and increase the tractor's engine rpm until it reaches the cutter full power take-off operating speed of 540 rpm. If everything is still running smoothly, once more raise the cutter to transport height to check for driveline bind or chatter. Lower the cutter to the ground, return the engine to a low idle, and disengage the power take-off. Position the adjustable stops on the tractor's 3-point lift lever so the cutter can be consistently returned to the same cutting height and transport height.

You should now be ready to transport to your cutting site at a safe ground speed. On roadways transport in such a manner that faster moving vehicles can easily see you and pass you safely. Reduce your speed when traveling over rough and hilly terrain. Avoid quick or sharp steering corrections. Take extra care to ensure that the mower doesn't come into contact with obstacles such as trees, buildings, or fences. Use accessory lights and appropriate reflective devices to provide adequate warning to pedestrians and other vehicle operators when traveling on public roads and in the dark of night. Comply with all local, state, and federal laws.

It is important that you inspect the area where you will be cutting and clear it of hazards and foreign objects before you start mowing. Never assume the area is clear. Cut only in areas you are familiar with and are free of foreign objects. Extremely tall grass should be cut twice to detect potential hazards. In the event you do strike an object, stop the cutter and tractor immediately to inspect and make any necessary repairs to the cutter before resuming operation. Remove or clearly mark the struck object to prevent hitting it again. It really pays to inspect a new area and to develop a safe plan before cutting.

You will need to maintain 540 rpm power take-off speed and 2 to 5 mph (3.2 to 8.0 km/h) ground speed to produce a clean cut. Make a tractor gear and range selection that will enable you to maintain these speed combinations. Generally the quality of cut is better at lower ground speeds. Dense ground cover will create the need to slow down even more. In certain conditions tractor tires will roll grass down resulting in an uneven cut when grass fails to rebound. Should this happen, you may try reversing the direction of cut and/or double cut to achieve the desired finish. Avoid very low cutting heights especially on extremely uneven terrain. Always cut downward on slopes and avoid crossing the face of steep slopes. Avoid sharp drops and cross diagonally through dips to prevent hanging up tractor and cutter. Slow down in turns. Remember to look back often.

Now that you're prepared and well briefed you may begin cutting. Begin by doing the following:

- Reducing tractor's engine rpm.
- Make sure cutter is on the ground in cutting position and then engage power take-off.
- Raise engine rpm to the appropriate 540 power take-off speed and begin cutting.

Make wide turns when possible. Three-point hitch and optional Quick Hitch models can be lifted into transport position to make tight turns and to reverse direction. Try increasing or decreasing ground speed to determine the effect on quality of cut. With a little practice you will be pleased with what you and your Land Pride Rotary Cutter can do.

Whether you are done mowing, need to take a break, or just need to make a few adjustments to the cutter, remember to always shut the tractor down using "**Tractor Shutdown Procedure**" on page 25.



## Section 5: Maintenance & Lubrication

### Maintenance

Proper servicing and adjustments are key to the long life of any implement. With careful inspection and routine maintenance, you can avoid costly downtime and repair.

Check all bolts and pins after using the implement for several hours and on a regular basis thereafter to ensure they are tight and secured. Tighten all loose hardware as indicated in the “**Torque Values Chart**” on page 40. Replace worn, damaged, or illegible safety labels by obtaining new labels from your Great Plains dealer.

Periodically, disengage power take-off, stop tractor, place gear selector in park or set park brake, turn off tractor, remove switch key and wait for blades to stop rotating before dismounting. Dismount tractor and check for objects wrapped around blade spindles. Block deck up before removing objects.

#### **DANGER**

*To avoid serious injury or death:*

*Always secure equipment with solid, non-concrete supports before working under it. Never go under equipment supported by concrete blocks or hydraulics. Concrete can break, hydraulic lines can burst, and/or hydraulic controls can be actuated even when power to hydraulics is off.*

#### **WARNING**

*To avoid serious injury or death:*

- *Always follow “Tractor Shutdown Procedure” provided in this manual before dismounting the tractor.*
- *Make sure controls are all in neutral position or park before starting the power machine.*
- *Perform scheduled maintenance. Check for loose hardware, missing parts, broken parts, structural cracks, and excessive wear. Make repairs before putting the implement back into service.*
- *Do not alter implement or replace parts on the implement with other brands. Other brands may not fit properly or meet OEM (Original Equipment Manufacturer) specifications. They can weaken the integrity and impair the safety, function, performance, and life of the implement. Replace parts only with genuine OEM parts.*
- *Buildup of debris around moving components and gearboxes is a fire hazard. Keep rotating parts and gearboxes free from debris.*
- *Improper oil level can cause bearing failure and be a fire hazard. Maintain proper gearbox oil level.*

### Hydraulic System

#### **WARNING**

*To avoid serious injury or death:*

*Hydraulic fluid under high pressure will penetrate the skin or eyes causing a serious injury. Wear protective gloves and safety glasses or goggles when working with hydraulic*

*systems. Use a piece of cardboard or wood rather than hands when searching for leaks. If an accident occurs, seek immediate emergency medical care or gangrene may result. DO NOT DELAY.*

One of the most important things you can do to prevent hydraulic system problems is to ensure your tractor's hydraulic reservoir remains free of dirt and other contaminations.

Use a clean cloth to wipe hose ends clean before attaching them to your tractor. Replace tractor hydraulic filter element at the prescribed intervals. These simple maintenances will go a long way to prevent occurrence of control valve and hydraulic cylinder problems.

Check for signs of damaged or worn hydraulic hoses, fittings and cylinders before each use of the cutter. Replace damaged components as needed. Order only genuine Great Plains parts from your local Great Plains dealer.

### Cutter Blade Maintenance

#### **DANGER**

*To avoid serious injury or death:*

- *Always disconnect the driveline from the power take-off shaft before servicing underside of cutter. The tractor can be started with the power take-off engaged.*
- *Always secure equipment with solid, non-concrete supports before working under it. Never go under equipment supported by concrete blocks or hydraulics. Concrete can break, hydraulic lines can burst, and/or hydraulic controls can be actuated even when power to hydraulics is off.*

#### **WARNING**

*To avoid serious injury or death:*

- *Do not operate cutter with blades that are out-of-balance, bent, excessively worn, excessively nicked, or with blade bolts that are excessively worn. Such blades can break loose at high speeds.*
- *Do not attempt to straighten a bent blade or weld on a blade. Do not attempt to modify a blade such as hard surfacing, heat treating, cold treating, or by any other method. Always replace blades with genuine OEM blades to assure safety.*

**IMPORTANT:** Only replace cutting blades in pairs with genuine OEM blades. Replacing single blades can result in an out-of-balance condition that will contribute to premature bearing wear/breakage and/or structural cracks in gearbox and/or deck.

Always inspect cutting blades before each use. Make certain they are properly installed and are in good working condition. Replace any blade that is damaged, worn, bent, or excessively nicked. Never try to straighten a bent blade! Small nicks can be ground out when sharpening.



## Section 5: Maintenance & Lubrication

Remove blades and sharpen or replace them as follows:

1. Place tractor gear selector in park and/or set brakes, shut engine off, and remove ignition key.
2. Disconnect main driveline from tractor power take-off and secure cutter deck in the up position with solid supports before servicing underside of cutter.

**Refer to Figure 5-1:**

3. Remove access cover (#5).
4. Rotate blade bolt (#1) until in alignment with access hole (A).
5. Unscrew locknut (#3) to remove cutting blade (#6). Blade bolt (#1) is keyed and will not turn freely.
6. Both blades should be sharpened at the same angle as the original cutting edge and must be replaced or re-ground at the same time to maintain proper balance in the cutting unit. The following precautions should be taken when sharpening blades:
  - a. Do not remove more material than necessary.
  - b. Do not heat and pound out a cutting edge.
  - c. Do not grind blades to a razor edge. Leave a blunt cutting edge approximately 1/16" (2 mm) thick.
  - d. Always grind cutting edge so end of blade remains square to cutting edge and not rounded.
  - e. Do not sharpen back side of blade.
  - f. Both blades should weigh the same with not more than 1 1/2 oz. (0.04 kg) difference. Unbalanced blades will cause excessive vibration which can damage gearbox bearings and create structural cracks.

**Refer to Figure 5-2:**

7. Carefully check cutting edges of blades in relation to blade carrier rotation to ensure correct blade placement. Blade Rotation is counterclockwise with cutting edge leading. Airfoil (lift) must be oriented towards the top of the deck.

**Refer to Figure 5-1:**

### **WARNING**

*To avoid serious injury or death:*

*A locknut that has been removed can lose its thread locking properties. Reusing a used locknut can result in a thrown blade. Always use a new locknut when installing blades.*

**IMPORTANT:** Examine blade bolts (#1) and flat washers (#2) for excessive wear and replace if worn.

8. Insert blade bolt (#1) through blade (#6), dish pan (#4), and flat washer (#2). Secure blade with a **new locknut (#3)** and torque to 450 ft-lbs (610 N-m).
9. Replace access cover (#5).
10. If replacing dishpan (#4), nut (#7) on gearbox output shaft should be torqued to 450 ft-lbs (610 N-m) minimum and secured with cotter pin (#8) with both legs bent opposite directions around the nut.

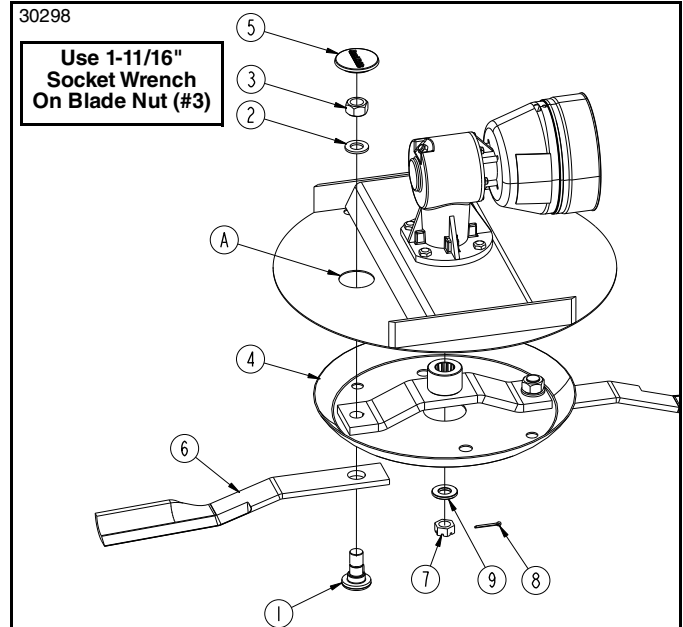

### Land Pride Rotary Cutter Blade Parts

Item	Part No.	Part Description
	326-185A	BLADE BOLT KIT (Items 1, 2, & 3 below)
1	802-920C	BLD BOLT 1 1/8-12 x 3 1/2" with 3/16" KEY
2	804-147C	WASHER FLAT 1 1/4 SAE PLAIN
3	803-170C	NUT HEX TOP LOCK 1 1/8-12 PLT.
4	326-367H	DISHPAN 15 1/2", RCR12 SERIES
5	840-273C	PLUG LP 3" ID RUBBER
6	820-065C	48" CUTTER BLADE 1/2 x 3 x 18 3/4 CCW
6	820-198C	60" CUTTER BLADE 1/2" x 3" x 25" CCW
6	820-199C	72" CUTTER BLADE 1/2" x 3 x 31" CCW
7	803-095C	NUT HEX SLOTTED 1-14
8	805-017C	PIN COTTER 3/16 X 1 3/4 PLT
9	804-070C	FLAT WASHER 1 SPECIAL

**Cutter Blade Assembly**  
Figure 5-1

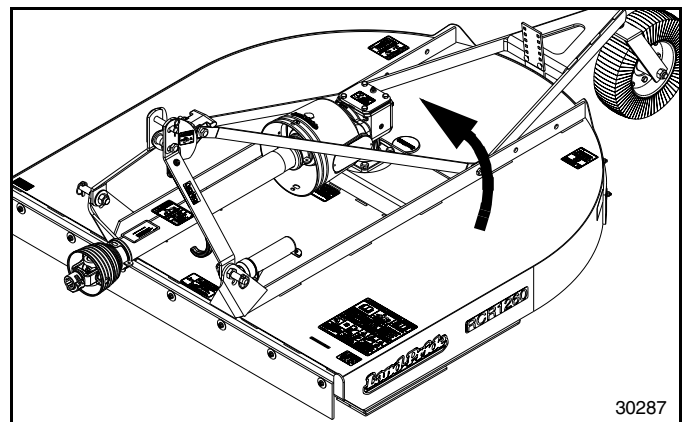

**Counterclockwise Blade Rotation**  
Figure 5-2



### Driveline Maintenance

#### **DANGER**

To prevent serious injury or death:

- Tractor power take-off shaft shield, driveline shields, and gearbox shaft shields must be installed and in good working condition to avoid driveline entanglement and projectiles flying off of the driveline.
- Always disconnect driveline from the tractor before servicing the drivetrain and components powered by the drivetrain. A person can become entangled in the drivetrain if the tractor is started and the power take-off is engaged.

#### **WARNING**

To prevent serious injury or death:

- Always follow “Tractor Shutdown Procedure” provided in this manual before dismounting the tractor.
- Do not operate a broken or bent driveline. Such a driveline will break apart while rotating at high speeds. Always remove the implement from use until the damaged driveline can be repaired or replaced.

The drive components are protected from shock loads with a shear bolt clutch shown in Figure 5-3 on this page or with a slip clutch shown in Figure 5-4 on page 31.

- For shear bolt instructions, refer to “**Driveline with Shear Bolt Clutch**” on this page .
- For slip clutch instructions, refer to “**Driveline with Slip Clutch**” on page 31.

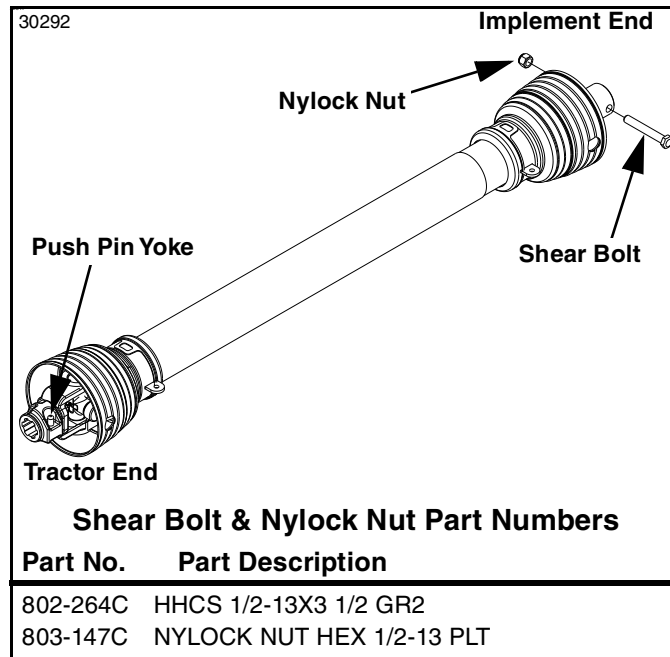

**Shear Bolt Protected Driveline  
Figure 5-3**

### Driveline with Shear Bolt Clutch

Refer to Figure 5-3:

**IMPORTANT:** Replace shear bolts with genuine OEM shear bolts.

Shock loads can cause shear bolt breakage. Avoid accidental breakage by engaging power take-off at a low engine rpm. Increase engine speed to 540 rpm only after the blades are rotating.

Should the cutter hit a solid object, the shear bolt will shear. Replace shear bolt as follows:

1. Shut tractor down according to “**Tractor Shutdown Procedure**” on page 25.
2. **Refer to Figure 1-3 on page 15:** Unsnap side access covers (#4) on the gearbox shield. Keep access covers for reuse.
3. At the implement end, align the holes in the driveline yoke with the hole in the gearbox input shaft. If the two holes cannot be aligned, disconnect the driveline from the tractor by pushing in on the push pin and pulling back on the driveline.
4. Install a new shear bolt in the yoke and secure it with a new nylock nut. Draw nylock nut up snug, do not torque the nut. Torquing the nut can prevent the shear bolt from shearing.
5. Reinstall access covers (#4).
6. If removed, reattach the driveline to the tractor. Refer to “**Driveline Hook-Up**” on page 17.

Section 5: Maintenance & Lubrication

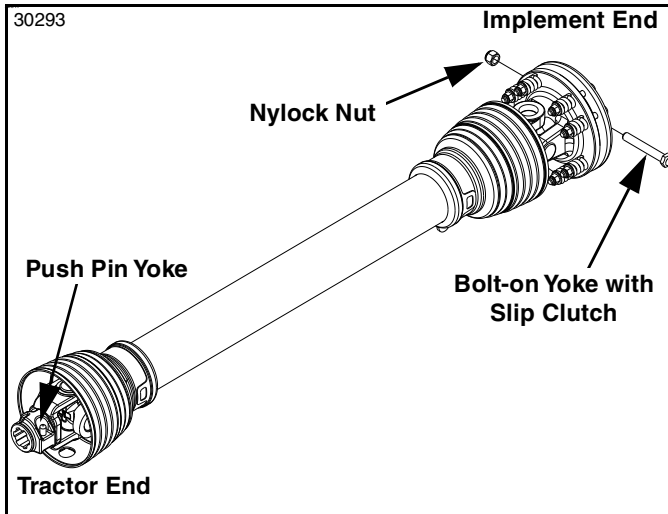

Slip Clutch Protected Driveline  
Figure 5-4

Driveline with Slip Clutch

Refer to Figure 5-4:

**WARNING**

To avoid serious injury or death:

Always follow “Tractor Shutdown Procedure” provided in this manual before dismounting the tractor.

The slip clutch is designed to protect the drivetrain from shock loads. To do this, the clutch must be capable of slippage during operation. To verify the clutch will slip, a “Clutch Run-in” operation must be completed.

**WARNING**

To avoid serious injury or death:

A slip clutch that has been in use or has slipped for as little as only two or three seconds during run-in may be too hot to touch. Allow a hot clutch to cool before working on it.

**IMPORTANT:** Prior to initial operation and after 30 days of inactivity, slip friction disks to remove oxidation and moisture. Moisture allows disks to slip easily. Oxidation can prevent disk from slipping causing driveline damage. This damage is NOT covered under the warranty.

Cutter drive components are protected from shock loads by either a two plate friction clutch or a shear bolt.

The shear bolt is designed to shear off when the blade impacts objects that the cutter is not designed to cut through. Avoid shear bolt failure by engaging the power take-off slowly at low engine rpm. See your Land Pride dealer when replacing shear bolts. Using higher grade shear bolt may result in driveline, gearbox, and/or tractor power take-off damage.

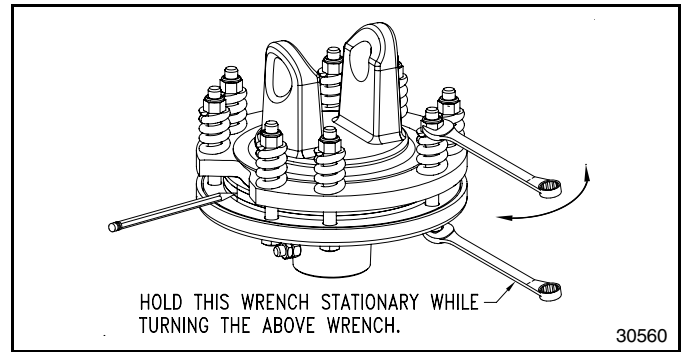

Clutch Run-In  
Figure 5-5

Clutch Run-In

The clutch must be capable of slippage during operation to protect gearbox, driveline, and other drive train parts. Friction clutches should be “run-in” prior to initial operation and after long periods of inactivity. To prevent driveline and gearbox damage, repeat clutch “run-in” at the beginning of each season and when moisture and/or condensation seizes the inner friction plates.

Refer to Figure 5-5:

1. Using a pencil or other marker scribe a line across the exposed edges of the clutch plates and friction disks.
2. Carefully loosen each of the 8 spring retainer nuts by exactly 2 revolutions. It will be necessary to hold the hex end of the retainer bolt in order to count the exact number of revolutions.
3. Start the tractor and engage the driveline drive for 2-3 seconds to permit slippage of the clutch surfaces. Disengage the driveline, then re-engage a second time for 2-3 seconds. Disengage driveline, shut off tractor, and remove key. Wait for all components to stop before dismounting from tractor.
4. Shut tractor down according to “Tractor Shutdown Procedure” on page 25.
5. Inspect the clutch and ensure that the scribed markings made on the clutch plates have changed position. Slippage has not occurred if any two marks on the friction disk and plate are still aligned. A clutch that has not slipped must be disassembled to separate the friction disk plates. See “Clutch Disassembly” to disassemble clutch.
6. Tighten each of the 8 spring retainer nuts on the clutch housing exactly 2 revolutions to restore the clutch to the original setting pressure.
7. The clutch should be checked during the first hour of operation and periodically each week. An additional set of scribe marks can be added to check for slippage. See “Clutch Assembly” to adjust for proper spring length.



### Clutch Disassembly

If the clutch run-in procedure, (See “Clutch Run-In” on page 31), indicated that one or more of the friction disks did not slip, the clutch must be disassembled to separate the friction discs.

1. Shut tractor down according to “Tractor Shutdown Procedure” on page 25.
2. Allow clutch to cool to ambient temperature before working on the clutch.
3. At the back of the tractor, push in and hold the push pin on the driveline yoke while pulling the driveline from the tractor’s power take-off shaft.
4. **Refer to Figure 1-3 on page 15:** At the cutter’s gearbox shield, unsnap side access covers (#4) and remove. Keep access covers for reuse.
5. **Refer to Figure 5-4 on page 31:** Remove nylock nut and bolt from the yoke and removed the driveline from the gearbox.

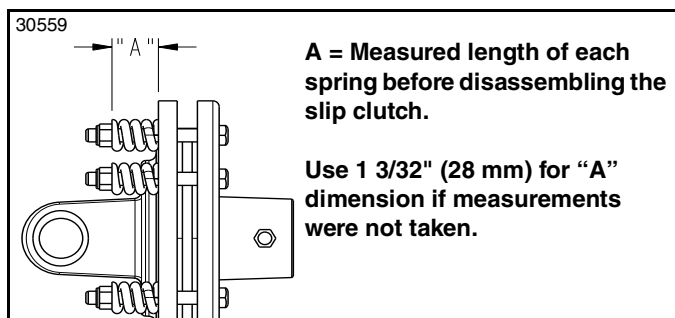

**Clutch Spring Adjustment**  
Figure 5-7

**Refer to Figure 5-7:**

**IMPORTANT: Be Sure to measure and record length (“A”) of each spring before disassembling the clutch.**

6. Measure and recording each spring length before disassembling the clutch.

**Refer to Figure 5-6:**

7. Remove spring retainer nuts (#1), springs (#2), and bolts (#3) from the assembly.
8. Each friction disk (#4) must then be separated from the metal surface adjacent to it.

### Inspection

1. Inspect all parts for excessive wear and condition. Clean all parts that do not require replacement. The original disk thickness is 1/8" (3 mm) and should be replaced if the thickness falls below 3/32" (2.4 mm).
2. If the clutch have been slipped to the point of “smoking”, the friction disks may be damaged and should be replaced. Heat build-up may also affect the yoke joints.

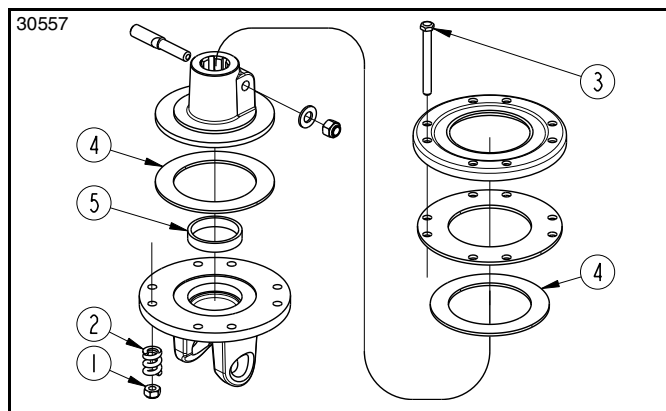

**Clutch Disassembly**  
Figure 5-6

### Clutch Assembly

**Refer to Figure 5-6:**

1. Reassemble each friction disk (#4) next to the metal plate it was separated from.
2. Make certain bushing (#5) is replaced in the same location as when it was removed.
3. Install bolts (#3) through end plates and intermediate plates as shown.
4. Place springs (#2) over the bolts and secure with nuts (#1).

**Refer to Figure 5-7:**

5. Progressively tighten each spring retainer bolt until correct spring height (“A” dimension) is reached.

**IMPORTANT:** Always lubricate the gearbox input shaft before reattaching the driveline to the gearbox. Refer to “Gearbox Input Shaft” on page 34.

6. Reattach driveline to the cutter. Refer to “Driveline Installation” on page 15.
7. If needed, hook-up driveline to the tractor. Refer to “Driveline Hook-Up” on page 17.





Section 5: Maintenance & Lubrication

**Long-Term Storage**

Clean, inspect, service, and make necessary repairs to the implement when storing it for long periods and at the end of the season. This will help to ensure the unit is ready for field use the next time you hook-up to it.

** DANGER**

To avoid serious injury or death:

- Always disconnect the driveline from the power take-off shaft before servicing drivetrain and cutter blades. The power take-off can be engaged if the tractor is started.
  - Always secure equipment with solid, non-concrete supports before working under it. Never go under equipment supported by concrete blocks or hydraulics. Concrete can break, hydraulic lines can burst, and/or hydraulic controls can be actuated even when power to hydraulics is off.
1. Clean off any dirt and grease that may have accumulated on the cutter and moving parts. Scrape off compacted dirt from the bottom of deck and then wash surface thoroughly with a garden hose. A coating of oil may also be applied to the lower deck area to minimize oxidation.
  2. See “**Cutter Blade Maintenance**” on page 28. Check blades and blade bolts for wear and replace if needed.
  3. Inspect for loose, damaged, or worn parts and adjust or replace as needed.
  4. Repaint parts where paint is worn or scratched to prevent rust. Ask your dealer for Land Pride aerosol touch-up paint. Paint is also available in touch-up bottles with brush, quarts, and gallon sizes by adding TU, QT, or GL to the end of the aerosol part number.

Land Pride Touch-up Paint	
Part No.	Part Description
821-011C	PAINT LP BEIGE SPRAY CAN
821-066C	PAINT ORANGE SPRAY CAN
821-070C	PAINT GP GLOSS BLACK SPRAY CAN

5. Replace all damaged or missing decals.
6. Be certain to purge gauge wheel spindle tube with grease to keep moisture out. Lubricate all other wear surfaces as noted under “**Lubrication Points**” on page 34.
7. Store cutter on a level surface in a clean, dry place. Inside storage will reduce maintenance and make for a longer cutter life.
8. Follow all unhooking instructions on page 26 when disconnecting tractor from cutter.

**Ordering Replacement Parts**

Land Pride offers equipment in factory standard Beige with black highlights. This implement is also available in Orange.

When ordering an optional color, the suffix number corresponding to the color must be added at the end of the part number. Parts ordered without the suffix number will be supplied in factory standard colors.

**82 . . . . . Orange      85 . . . . . Black**

For example, if you are ordering a replacement part with part number 555-555C and the existing part is orange, then add the suffix 82 to the end of the number to make the part number read 555-555C82.



### Lubrication Points

<b>Lubrication Legend</b>	Multi-purpose spray lube	Multi-purpose grease lube	Multi-purpose oil lube	<b>50 Hrs</b> Intervals in hours at which lubrication is required

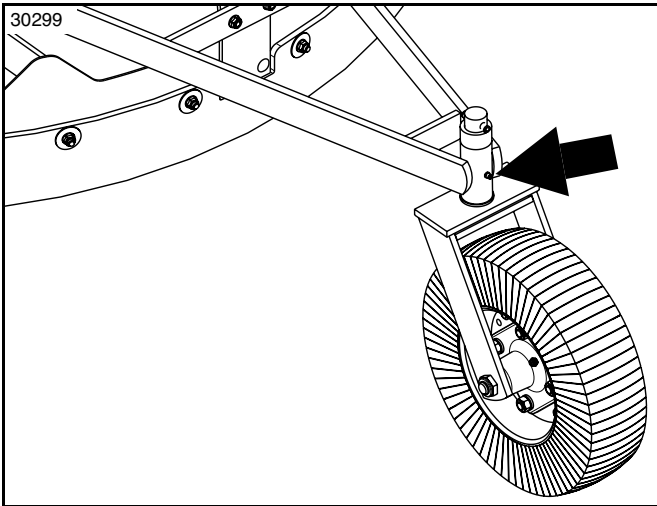

	<b>8 Hours</b>
--	----------------

#### Gauge Wheel Spindle Tube

**IMPORTANT:** See step 6 under “**Long-Term Storage**” on page 33 when parking unit for an extended period.

Type of Lubrication: Multi-purpose Grease  
Quantity = Until grease purges from spindle tube.

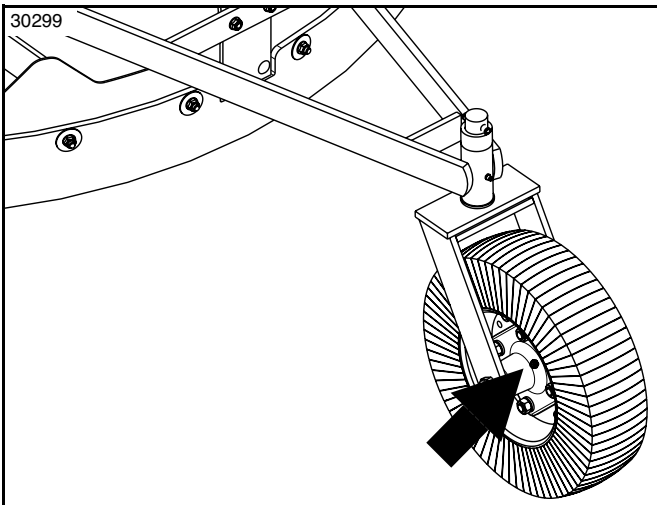

	<b>8 Hours</b>
--	----------------

#### Gauge Wheel Hub

The gauge wheel hub is equipped with a relief hole located directly opposite the grease fitting. The relief hole releases pressure from inside the hub casting when it is greased. The hub should be greased until grease purges from the relief hole.

Type of Lubrication: Multi-purpose Grease  
Quantity = Until grease purges from the relief hole.

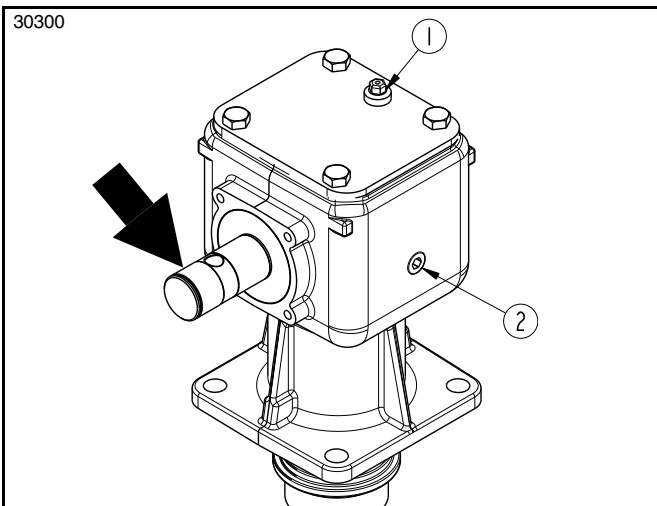

	<b>As Required</b>
--	--------------------

#### Gearbox Input Shaft

Always lubricate all surfaces of the gearbox input shaft before installing the driveline. At the beginning of each season, remove the driveline from the gearbox and lubricate all surfaces of the gearbox input shaft.

Type of Lubrication: Multi-Purpose  
Quantity = Thin Coat

## Section 5: Maintenance & Lubrication

30300

**Do Not Overfill!!**

**NOTE:** Use a suction or siphon pump to drain gearboxes of oil when there is not an oil drain plug.

### Gearbox

**NOTE:** Do not overfill! Cutter should be level when checking oil. Oil expands when hot, therefore, always check oil level when cold.

Remove rear oil plug (#2). If oil is below bottom of plug hole, add recommended gear lube through top vented plug hole until oil flows out of rear plug hole. Reinstall and tighten rear oil plug (#2) and top vented plug (#1).

Type of Lubrication: 80-90W EP Gear Lube

Quantity = Fill until oil begins to flow out rear plug hole in gearbox.

30561

### Driveline U-Joints

Type of Lubrication: Multi-purpose Grease

Quantity = 6 pumps

30561

### Driveline Shield Bearings

Type of Lubrication: Multi-purpose Grease

Quantity = 6 pumps

30303

### Driveline Profiles

Quantity = Clean & coat the inner tube of the driveline with a light film of Multi-purpose Grease and then reassemble.

# Table of Contents

## Section 6: Specifications & Capacities



### RCR12 Series

Specifications & Capacities				
Model Numbers	RCR1242	RCR1248	RCR1260	RCR1272
<b>Weight (With shear bolt driveline, laminated tire, front guard, and rear guard except as noted)</b>	385 lbs. (175 kg) without rear guard	413 lbs. (187 kg)	496 lbs. (225 kg)	568 lbs. (258 kg)
<b>Hitch</b>	Category I (Quick hitch ready)			
<b>Cutting Width</b>	42" (1.07 m)	48" (1.22 m)	60" (1.52 m)	72" (1.83 m)
<b>Overall Width</b>	45 1/4" (1.15 m)	53 5/8" (1.36 m)	64 1/4" (1.63 m)	76 1/2" (1.94 m)
<b>Overall Length (Including Tailwheel)</b>	83" (2.11 m)	89 1/8" (2.26 m)	97 3/4" (2.48 m)	110" (2.79 m)
<b>Deck Height</b>	7 1/4" (18.4 cm)			
<b>Cutting Height</b>	1 1/4" - 10" (3.2cm. - 25.4 cm)			
<b>Cutting Capacity</b>	Grass, weeds & light brush			
<b>Recommended Tractor Horsepower</b>	18-40 hp (13.4-29.8 kw)	20-60 hp (14.9-44.7 kw)	25 -60 hp (18.6-44.7 kw)	
<b>Power Take-Off Speed</b>	540 rpm			
<b>Gearbox Rating Horsepower</b>	60 hp (44.7 kw)			
<b>Gearbox (Speed up beveled gears)</b>	1:1.93 Speed-up Cast iron housing			1:1.47 Speed-up Cast iron housing
<b>Gearbox Lubrication &amp; Capacity</b>	1.9 Pint (.9 L) With new Comer gearboxes - 1.1 Pint (0.52 L) of gear lube 80-90W EP			
<b>Deck Construction</b>	1 Piece reinforced deck			2 Piece reinforced deck
<b>Deck Material Thickness</b>	12 Gauge (2.7 mm)			
<b>Skids</b>	12 Gauge (2.7 mm) (Formed in deck)		1/4" (6.35 mm) (Welded on deck)	
<b>Skid Shoes</b>	Not Available		Bolt-on replaceable skid shoes (Sold separately through parts department only)	
<b>Stump Jumper</b>	Round Pan 10 ga x 24" (61.0 cm)			
<b>Blades (2)</b>	1/2" x 3" (13mm x 76 mm) Heat treated alloy steel Free-swinging blades			
<b>Blade Bolts</b>	Keyed with harden flat washer and locknut			
<b>Blade Tip Speed</b>	11,417 fpm (58.0 mps)	13,256 fpm (67.3 mps)	16,536 fpm (84.0 mps)	15,033 fpm (76.4 mps)
<b>Driveline</b>	ASAE Category 3			
<b>Driveline Protection Options</b>	1/2" (13 mm) Center shear bolt protection or center bolt 2 plate slip clutch			
<b>Tailwheel</b>	4" x 8" Laminated tire and yoke			
<b>Front rubber safety guard</b>	Standard	Standard	Standard	Standard
<b>Rear rubber safety guard</b>	Not available	Standard	Standard	Standard



RCR1242 = 45 1/4" (1.15 m)  
 RCR1248 = 53 5/8" (1.36 m)  
 RCR1260 = 64 1/4" (1.63 m)  
 RCR1272 = 76 1/2" (1.94 m)

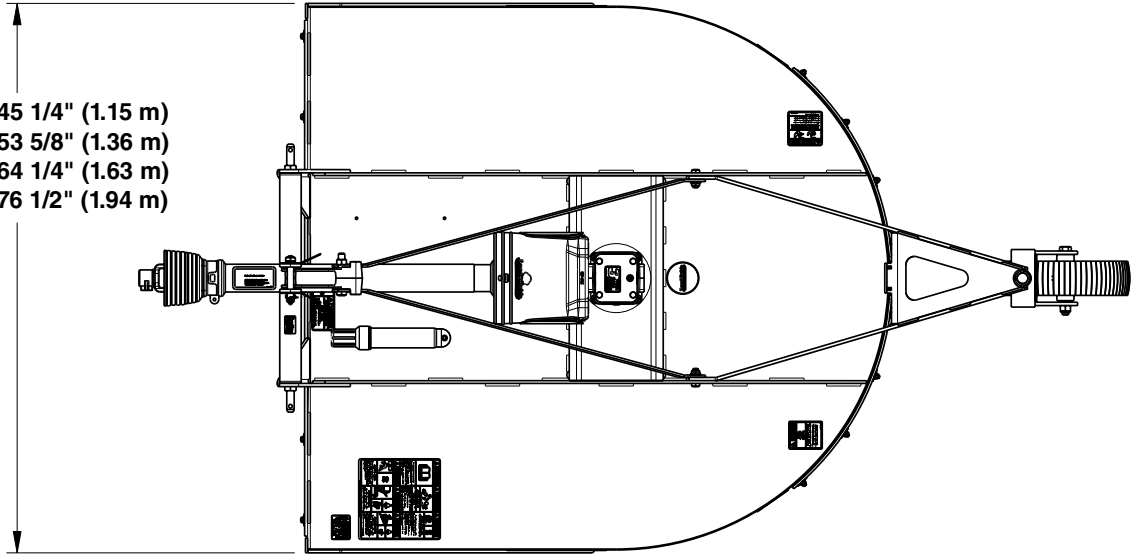

RCR1242 = 83" (2.11 m)  
 RCR1248 = 89 1/8" (2.26 m)  
 RCR1260 = 97 3/4" (2.48 m)  
 RCR1272 = 110" (2.79 m)

RCR1242 = 45 1/8" (1.15 m)  
 RCR1248 = 40 3/4" (1.04 m)  
 RCR1260 = 44 1/4" (1.12 m)  
 RCR1272 = 44 1/8" (1.12 m)

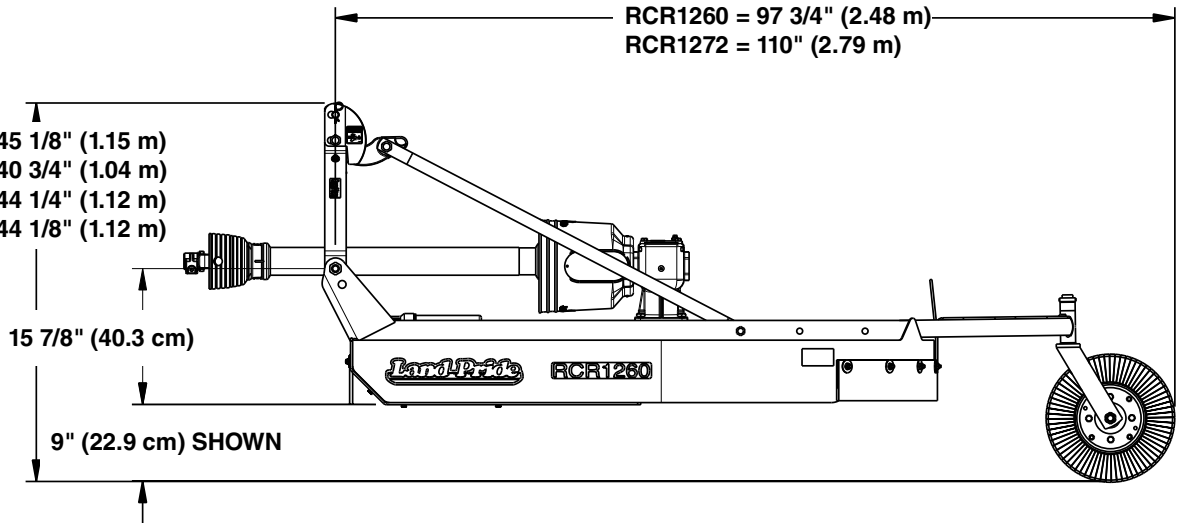

30320





### RCR12 Series

Features	Benefits
<b>Surpassed rugged industry standards</b>	All Land Pride cutters have been designed and tested and meet rigorous voluntary testing procedures specified by ANSI.
<b>Tractor Horsepower range</b>	18 - 60 hp (13-45 kW)
<b>3 Year gearbox warranty</b>	Shows our confidence in the gearbox integrity.
<b>Cat. 3 driveline with shear-bolt</b>	Shear bolt offers maximum driveline protection.
<b>Cat. 3 driveline with 2-plate slip-clutch</b>	Slip-clutch driveline offers convenience for continual work.
<b>Floating top link</b>	Provides for easy hook-up. Permits deck to follow the terrain for an even cut. Two hole position to allow greater lift leverage for smaller tractors.
<b>Round back design</b>	Helps discharge grass better than enclosed or partially enclosed cutters.
<b>Cutting Height 1 1/4" - 10" (3.2-25.4 cm)</b>	Cutting height for wide range of cutting conditions.
<b>Skid shoes (Accessory) RCR1260 &amp; RCR1272 only</b>	Provides sidewall reinforcement and helps protect bottom of sidewall.
<b>Heat-treated free swinging blades</b>	Free swinging protects from obstructions. Heat-treated offers longer life.
<b>Splined blade bar hub</b>	Allows for tight positive fit of stump jumper and blade bar to gearbox output shaft.
<b>10 Gauge stump jumper</b>	Allows cutter to slide over obstructions protecting the gearbox output shaft.
<b>High blade tip speed</b>	Ensures clean cut.
<b>Laminated tailwheel</b>	Laminated material is long lasting in rough conditions and can't go flat.
<b>Heavy-duty spindle on tailwheel</b>	1 1/4" spindle gives the strength to protect tailwheel assembly.
<b>Rubber guarding</b>	Protect against flying debris.
<b>Metal Guarding</b>	Protects against flying debris.



### RCR12 Series

Problem	Cause	Solution
<b>Oil seal leaking</b>	Gearbox overfilled	Drain to side plug hole
	Seals damaged	Replace seals
	Grass or wire wrapped on shaft in seal area	check seal areas daily
<b>Driveline yoke or cross failing</b>	Shock load	Avoid hitting solid objects
	Needs lubrication	Lubricate every 8 hours
<b>Driveline clutch is slipping</b>	Scalping the ground	Raise cutting height
	Cutting too fast	Reduce travel speed
	power take-off being engaged too fast at high engine rpm	Slowly engage power take-off at low engine rpm
	Cutting over solid objects	Avoid solid objects
	Clutch spring not set correctly	Check dimension for spring setting on clutch
<b>Bent Driveline (NOTE: driveline should be repaired or replaced if bent)</b>	Contacting frame	Reduce lift height in transport position
	Contacting drawbar	Reposition drawbar
	Bottoming out	Shorten driveline
<b>Driveline telescoping tube failing</b>	Needs lubrication	Lubricate every 20 hours
	Shock load	Avoid hitting solid objects
<b>Driveline telescoping tube wearing</b>	Needs lubrication	Lubricate every 20 hours
<b>Blades wearing excessively</b>	Cutting on sandy ground	Raise cutting height
	Contacting ground frequently	Raise cutting height
<b>Blades breaking</b>	Hitting solid objects	Avoid hitting solid objects
<b>Blades coming loose</b>	Blades not tightened properly	Tighten blade hardware (refer to "Cutter Blade Maintenance" on page 28)
	Not using new nut when replacing blades	Use new nuts
<b>Blade carrier becomes loose</b>	Running loose in the past	Replace gearbox output shaft and blade carrier
	Blade carrier hardware not tight enough	Tighten to specified torque
<b>Blade bolt holes worn</b>	Blade hardware running loose	Replace blades, blade bolts, and nuts if worn
<b>Blade carrier bent</b>	Hitting solid objects	Avoid hitting solid objects and replace blade carrier
<b>Excessive side skid wear</b>	Cutting height not level	Adjust cutter height
	Soil abrasive	Adjust cutter height
	Cutting too low	Adjust cutter height
<b>Tail wheel support failing</b>	Lowering too fast	Adjust rate of drop
	Hitting objects when turning	Reduce speed on turns
<b>Excessive vibration</b>	Driveline bent	Replace driveline
	Blades loose	Tighten blade bolts
	Blade carrier bent	Replace blade carrier
	Blade broken	Replace blade
	Blade will not swing	Remove and inspect blade
	Blades have unequal weight	Replace both blades
	Dishpan bent	Replace dishpan



Section 9: Torque Values Chart

Torque Values Chart for Common Bolt Sizes													
Bolt Size (inches)	Bolt Head Identification						Bolt Size (Metric)	Bolt Head Identification					
	Grade 2		Grade 5		Grade 8			Class 5.8		Class 8.8		Class 10.9	
in-tpi <sup>1</sup>	N · m <sup>2</sup>	ft-lb <sup>3</sup>	N · m	ft-lb	N · m	ft-lb	mm x pitch <sup>4</sup>	N · m	ft-lb	N · m	ft-lb	N · m	ft-lb
1/4" - 20	7.4	5.6	11	8	16	12	M 5 X 0.8	4	3	6	5	9	7
1/4" - 28	8.5	6	13	10	18	14	M 6 X 1	7	5	11	8	15	11
5/16" - 18	15	11	24	17	33	25	M 8 X 1.25	17	12	26	19	36	27
5/16" - 24	17	13	26	19	37	27	M 8 X 1	18	13	28	21	39	29
3/8" - 16	27	20	42	31	59	44	M10 X 1.5	33	24	52	39	72	53
3/8" - 24	31	22	47	35	67	49	M10 X 0.75	39	29	61	45	85	62
7/16" - 14	43	32	67	49	95	70	M12 X 1.75	58	42	91	67	125	93
7/16" - 20	49	36	75	55	105	78	M12 X 1.5	60	44	95	70	130	97
1/2" - 13	66	49	105	76	145	105	M12 X 1	90	66	105	77	145	105
1/2" - 20	75	55	115	85	165	120	M14 X 2	92	68	145	105	200	150
9/16" - 12	95	70	150	110	210	155	M14 X 1.5	99	73	155	115	215	160
9/16" - 18	105	79	165	120	235	170	M16 X 2	145	105	225	165	315	230
5/8" - 11	130	97	205	150	285	210	M16 X 1.5	155	115	240	180	335	245
5/8" - 18	150	110	230	170	325	240	M18 X 2.5	195	145	310	230	405	300
3/4" - 10	235	170	360	265	510	375	M18 X 1.5	220	165	350	260	485	355
3/4" - 16	260	190	405	295	570	420	M20 X 2.5	280	205	440	325	610	450
7/8" - 9	225	165	585	430	820	605	M20 X 1.5	310	230	650	480	900	665
7/8" - 14	250	185	640	475	905	670	M24 X 3	480	355	760	560	1050	780
1" - 8	340	250	875	645	1230	910	M24 X 2	525	390	830	610	1150	845
1" - 12	370	275	955	705	1350	995	M30 X 3.5	960	705	1510	1120	2100	1550
1-1/8" - 7	480	355	1080	795	1750	1290	M30 X 2	1060	785	1680	1240	2320	1710
1-1/8" - 12	540	395	1210	890	1960	1440	M36 X 3.5	1730	1270	2650	1950	3660	2700
1-1/4" - 7	680	500	1520	1120	2460	1820	M36 X 2	1880	1380	2960	2190	4100	3220
1-1/4" - 12	750	555	1680	1240	2730	2010	<sup>1</sup> in-tpi = nominal thread diameter in inches-threads per inch <sup>2</sup> N · m = newton-meters <sup>3</sup> ft-lb= foot pounds <sup>4</sup> mm x pitch = nominal thread diameter in millimeters x thread pitch						
1-3/8" - 6	890	655	1990	1470	3230	2380							
1-3/8" - 12	1010	745	2270	1670	3680	2710							
1-1/2" - 6	1180	870	2640	1950	4290	3160							
1-1/2" - 12	1330	980	2970	2190	4820	3560							
Torque tolerance + 0%, -15% of torquing values. Unless otherwise specified use torque values listed above. All locknuts or lubricated fasteners: Use 75% of torque value. (i.e. 1/2"-13 GR5 = 76 ft-lb; 75% of 76 or .75 x 76 = 57 ft-lb).													
Additional Torque Values													
Blade Bolt Locknut			450 ft-lbs (610 N·m)										
Blade Carrier Hub Nut			450 ft-lbs (610 N·m) Minimum										

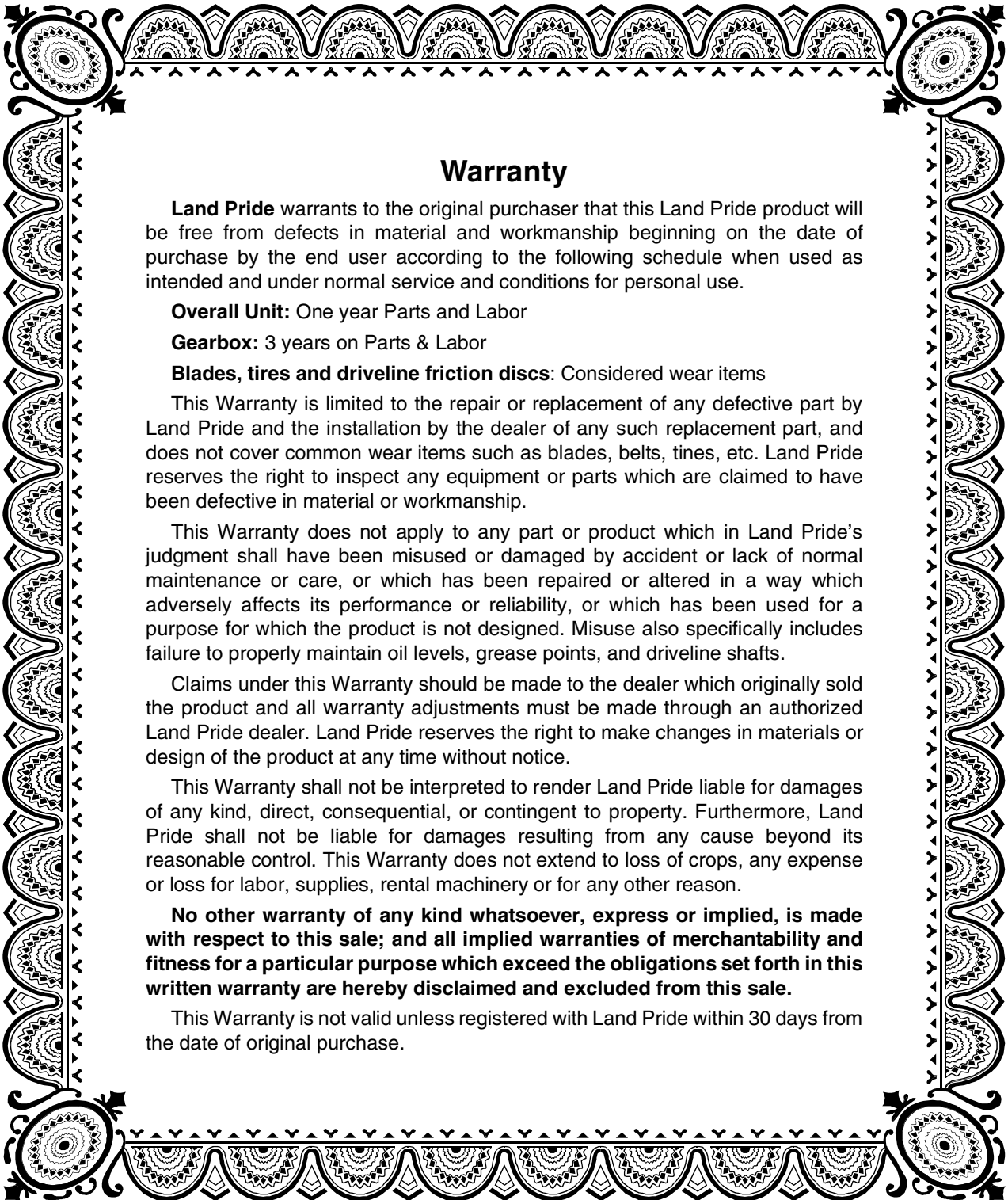

## Warranty

**Land Pride** warrants to the original purchaser that this Land Pride product will be free from defects in material and workmanship beginning on the date of purchase by the end user according to the following schedule when used as intended and under normal service and conditions for personal use.

**Overall Unit:** One year Parts and Labor

**Gearbox:** 3 years on Parts & Labor

**Blades, tires and driveline friction discs:** Considered wear items

This Warranty is limited to the repair or replacement of any defective part by Land Pride and the installation by the dealer of any such replacement part, and does not cover common wear items such as blades, belts, tines, etc. Land Pride reserves the right to inspect any equipment or parts which are claimed to have been defective in material or workmanship.

This Warranty does not apply to any part or product which in Land Pride's judgment shall have been misused or damaged by accident or lack of normal maintenance or care, or which has been repaired or altered in a way which adversely affects its performance or reliability, or which has been used for a purpose for which the product is not designed. Misuse also specifically includes failure to properly maintain oil levels, grease points, and driveline shafts.

Claims under this Warranty should be made to the dealer which originally sold the product and all warranty adjustments must be made through an authorized Land Pride dealer. Land Pride reserves the right to make changes in materials or design of the product at any time without notice.

This Warranty shall not be interpreted to render Land Pride liable for damages of any kind, direct, consequential, or contingent to property. Furthermore, Land Pride shall not be liable for damages resulting from any cause beyond its reasonable control. This Warranty does not extend to loss of crops, any expense or loss for labor, supplies, rental machinery or for any other reason.

**No other warranty of any kind whatsoever, express or implied, is made with respect to this sale; and all implied warranties of merchantability and fitness for a particular purpose which exceed the obligations set forth in this written warranty are hereby disclaimed and excluded from this sale.**

This Warranty is not valid unless registered with Land Pride within 30 days from the date of original purchase.

**IMPORTANT:** The Online Warranty Registration should be completed by the dealer at the time of purchase. This information is necessary to provide you with quality customer service.

Model Number \_\_\_\_\_

Serial Number \_\_\_\_\_



Corporate Office: P.O. Box 5060  
Salina, Kansas 67402-5060 USA  
[www.landpride.com](http://www.landpride.com)

---