

# Instructions for Parts Books

The heading at the top of the page will be the same for the picture of the parts at it is for the page with the part numbers.

Definition of column headings on part number pages:

**REF.No** → The number referring to the part on the picture page of the parts book.

**Part No.** → The number assigned to this part at the time of printing the parts book.

**Description** → Discription of part.

**Q'ty** → Quantity of part used on that page.

**S.No.** → Serial number range of the equipment that this part will fit.

>= Your serial number should be greater than or equal to the number shown.

<= Your serial number should be lesser than or equal to the serial number shown.

**I/C** → Interchangeability of part shown.

↔ The part shown will work for the older and later serial number.

# The part shown is not interchangeable with the other serial number.

← new for old

→ old for new

**Remarks** → Notes about this particulart part. Sometimes this may say except [FR] or [CA]

## Note about Country Codes:

The parts books we use in the United States of America may also contain information about a part that would be different in another country. It is important that you are aware of the country codes in some instances.

Symbol	Country
A	United States of America
CA	Canada
FR	France
GR	Greece
PO	Portugal
AU	Australia

If the remarks column says for example EXCEPT [FR] this part works in all countries except France. That means it will work here in the USA.

**ALL PRODUCT INDEX  
BX23D**

---

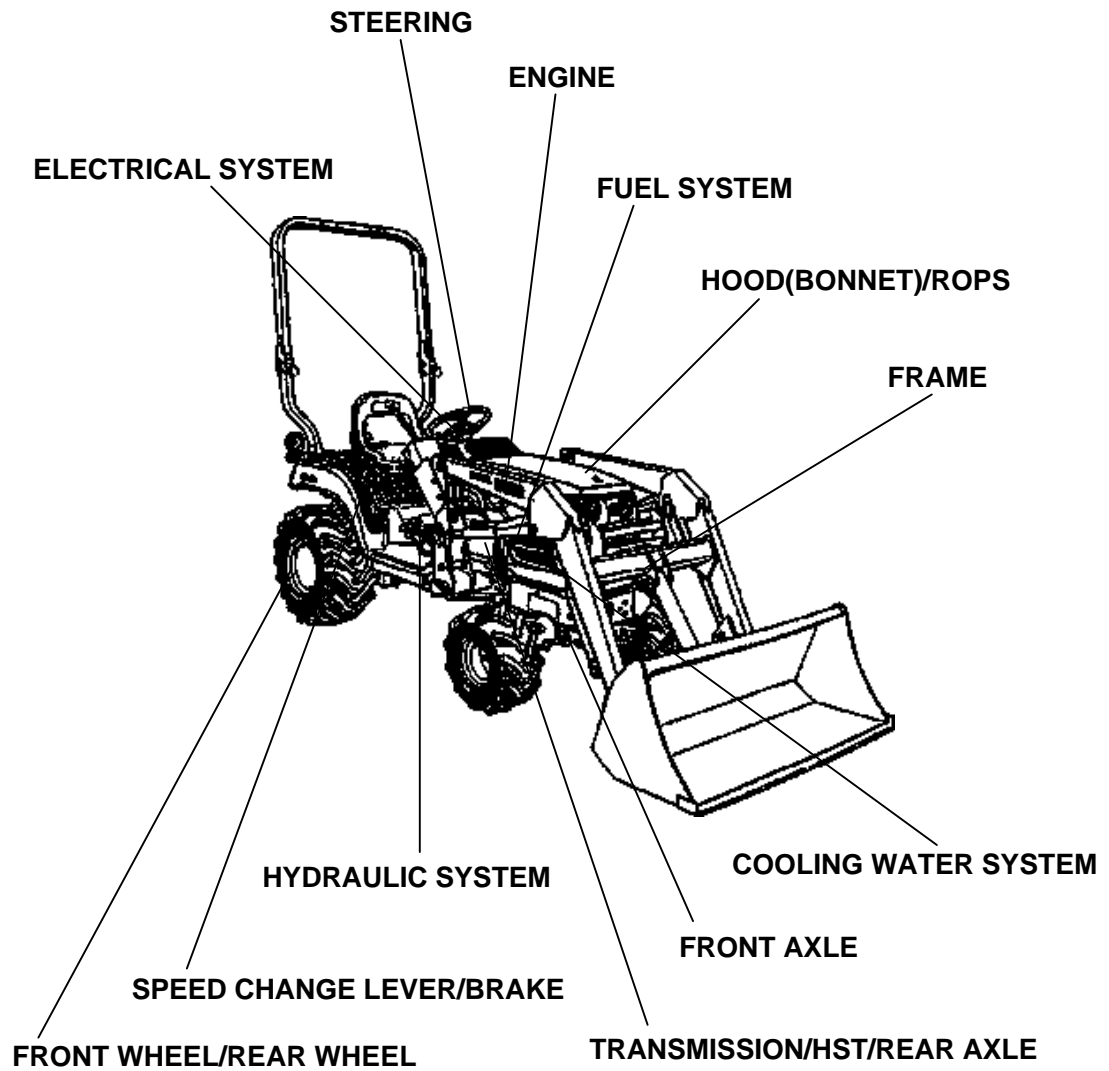

**LABELS**

**OPTION**

**ACCESSORIES**

Item	Part No.	Description	Book	
ENGINE	011001	CRANKCASE	100Z0254	
	011002	OIL PAN	100Z0254	
	011003	CYLINDER HEAD	100Z0254	
	011004	GEAR CASE	100Z0254	
	011005	HEAD COVER	100Z0254	
	011006	OIL FILTER	100Z0254	
	011007	DIPSTICK AND GUIDE	100Z0254	
	011100	MAIN BEARING CASE	100Z0254	
	011101	CAMSHAFT AND IDLE GEAR SHAFT	100Z0254	
	011102	PISTON AND CRANKSHAFT	100Z0254	
	011103	FLYWHEEL	100Z0254	
	011105	FUEL CAMSHAFT AND GOVERNOR SHAFT	100Z0254	
	011200	IDLE APPARATUS	100Z0254	
	011201	STOP SOLENOID	100Z0254	
	011202	INJECTION PUMP	100Z0254	
	011204	GOVERNOR	100Z0254	
	011205	SPEED CONTROL PLATE	100Z0254	
	011206	NOZZLE HOLDER AND GLOW PLUG	100Z0254	
	011207	NOZZLE HOLDER [COMPONENT PARTS]	100Z0254	
	011305	COVER	100Z0254	
	011400	DYNAMO AND PULLEY	100Z0254	
	011401	DYNAMO [COMPONENT PARTS]	100Z0254	
	011404	STARTER	100Z0254	
	011405	STARTER [COMPONENT PARTS]	100Z0254	
	011406	OIL SWITCH/THERMOMETER AND PLUG	100Z0254	
	011500	WATER FLANGE AND THERMOSTAT	100Z0254	
	011501	WATER PUMP	100Z0254	
	011504	FAN	100Z0254	
	011600	VALVE AND ROCKER ARM	100Z0254	
	011601	INLET MANIFOLD	100Z0254	
	011602	EXHAUST MANIFOLD	100Z0254	
	011700	HYDRAULIC PUMP	100Z0254	
	011701	HYDRAULIC PUMP [COMPONENT PARTS]	100Z0254	
	011900	UPPER GASKET KIT	100Z0254	
	011901	LOWER GASKET KIT	100Z0254	
	011603	AIR CLEANER	100Z0254	
	011605	MUFFLER	100Z0254	
	011703	HYDRAULIC PUMP COVER	100Z0254	
	01A001	ACCELERATOR LEVER	100Z0254	
	FUEL SYSTEM	01A101	FUEL TANK	100Z0254
		01A110	FUEL PIPE	100Z0254
	COOLING WATER SYSTEM	01A410	WATER PIPE	100Z0254
		01A420	RADIATOR	100Z0254
	ELECTRICAL SYSTEM	01A535	BATTERY	100Z0254
		01B115	PANEL BOARD	100Z0254
		01B215	SWITCH/SENSOR	100Z0254
		01B30102	HEAD RIGHT	100Z0254
	01B303	HAZARD LIGHT/TAIL LIGHT	100Z0254	
	01B310	WINKER LAMP	100Z0254	
	01B50102	ELECTRICAL WIRING	100Z0254	
FRAME	01C413	FRONT FRAME	100Z0254	
	01C417	SUB FRAME	100Z0254	
	01C419	ENGINE SUPPORT	100Z0254	
TRANSMISSION/HST/REAR AXLE	01C420	TRANSMISSION CASE	100Z0254	
	01C427	REAR AXLE CASE	100Z0254	
	01D001	CLUTCH SHAFT/OUTPUT SHAFT	100Z0254	
	01D005	PROPELLER SHAFT	100Z0254	

Item	Part No.	Description	Book
TRANSMISSION/HST/REAR AXLE	01D010	HST	100Z0254
	01D015	HST [COMPONENT PARTS]	100Z0254
	01D107	RANGE GEAR SHAFT	100Z0254
	01D135	PTO SHAFT	100Z0254
	01D137	MID PTO	100Z0254
	01D140	REAR DIFFERENTIAL	100Z0254
	01D141	FWD IDLE SHAFT	100Z0254
	01D142	GP IDLE SHAFT	100Z0254
	01D143	FRONT WHEEL PROPELLER SHAFT	100Z0254
	01D217	RANGE GEAR SHIFT FORK	100Z0254
	01D220	PTO GEAR SHIFT FORK	100Z0254
	01D222	PTO GEAR SHIFT ARM	100Z0254
	01D225	DIFFERENTIAL LOCK SHIFT FORK	100Z0254
	01D301	REAR AXLE	100Z0254
	SPEED CHANGE LEVER/BRAKE	01E001	BRAKE
01F10702		NEUTRAL HOLDER LINK	100Z0254
01F108		SPEED CONTROL PEDAL	100Z0254
01F11002		RANGE GEAR SHIFT LEVER	100Z0254
01F113		FRONT WHEEL DRIVE LEVER	100Z0254
01F122		PTO SELECT LEVER	100Z0254
01F12502		PTO GEAR SHIFT LEVER	100Z0254
01F143		HYDRAULIC CONTROL LEVER	100Z0254
01F201		BRAKE PEDAL	100Z0254
01F205		DIFFERENTIAL LOCK PEDAL	100Z0254
FRONT AXLE	01G110	FRONT DIFFERENTIAL CASE	100Z0254
	01G115	FRONT DIFFERENTIAL	100Z0254
	01G120	DIFFERENTIAL GEAR SHAFT	100Z0254
	01G125	FRONT AXLE CASE	100Z0254
	01G130	FRONT AXLE	100Z0254
STEERING	01H101	STEERING HANDLE	100Z0254
	01H110	STEERING CONTROLLER	100Z0254
	01H120	STEERING LINKAGE	100Z0254
	01H122	STEERING CYLINDER [COMPONENT PARTS]	100Z0254
HYDRAULIC SYSTEM	01J201	HYDRAULIC OIL LINE(SUCTION)	100Z0254
	01J210	HYDRAULIC OIL LINE(DELIVERY)	100Z0254
	01J215	HYDRAULIC OIL LINE(STEERING)	100Z0254
	01J301	HYDRAULIC CYLINDER	100Z0254
	01J310	HYDRAULIC PISTON/LIFT ARM	100Z0254
	01J405	CONTROL VALVE	100Z0254
	01J410	CONTROL VALVE [COMPONENT PARTS]	100Z0254
	01K114	TOP LINK	100Z0254
	01K115	LOWER LINK	100Z0254
	01K116	LIFT ROD	100Z0254
HOOD(BONNET)/ROPS	01K123	TOP LINK BRACKET/FENDER BRACKET	100Z0254
	01K130	MOWER REAR LINK RH	100Z0254
	01K131	MOWER REAR LINK LH	100Z0254
	01L125	PTO PROTECTOR	100Z0254
	01M100	FRONT GUARD	100Z0254
	01M10202	FRONT GLILLE SUPPORT	100Z0254
	01M105	BONNET	100Z0254
	01M11002	BONNET SIDE	100Z0254
	01M135	CENTER PILLAR	100Z0254
	01M201	PANEL FRAME	100Z0254
01M210	FENDER	100Z0254	
01M217	SEAT SUPPORT	100Z0254	
01M220	SEAT	100Z0254	
01M225	STEP	100Z0254	

Item	Part No.	Description	Book
HOOD(BONNET)/ROPS	01M30102	ROPS	100Z0254
	01M501	SMV EMBLEM	100Z0254
FRONT WHEEL/REAR WHEEL	01R10101	FRONT WHEEL (18*8.50-8)	100Z0254
	01R10102	FRONT WHEEL (18*8.50-8)	100Z0254
	01R11001	REAR WHEEL (26*12.00-12)	100Z0254
	01R11002	REAR WHEEL (26*12.00-12)	100Z0254
LABELS	01S10202	LABEL (FRONT) [ENGLISH]	100Z0254
	01S10204	LABEL (FRONT) [FRENCH]	100Z0254
	01S10302	LABEL (REAR) [ENGLISH]	100Z0254
	01S10304	LABEL (REAR) [FRENCH]	100Z0254
ACCESSORIES	01T105	ACCESSORIES AND SERVICE PARTS	100Z0254
OPTION	01U80002	ALTERNATOR KIT [OPTION]	100Z0254
	01U802	ALTERNATOR [COMPONENT PARTS][OPTION]	100Z0254
	01U805	WARKING LIGHT KIT [OPTION]	100Z0254

# CRANKCASE

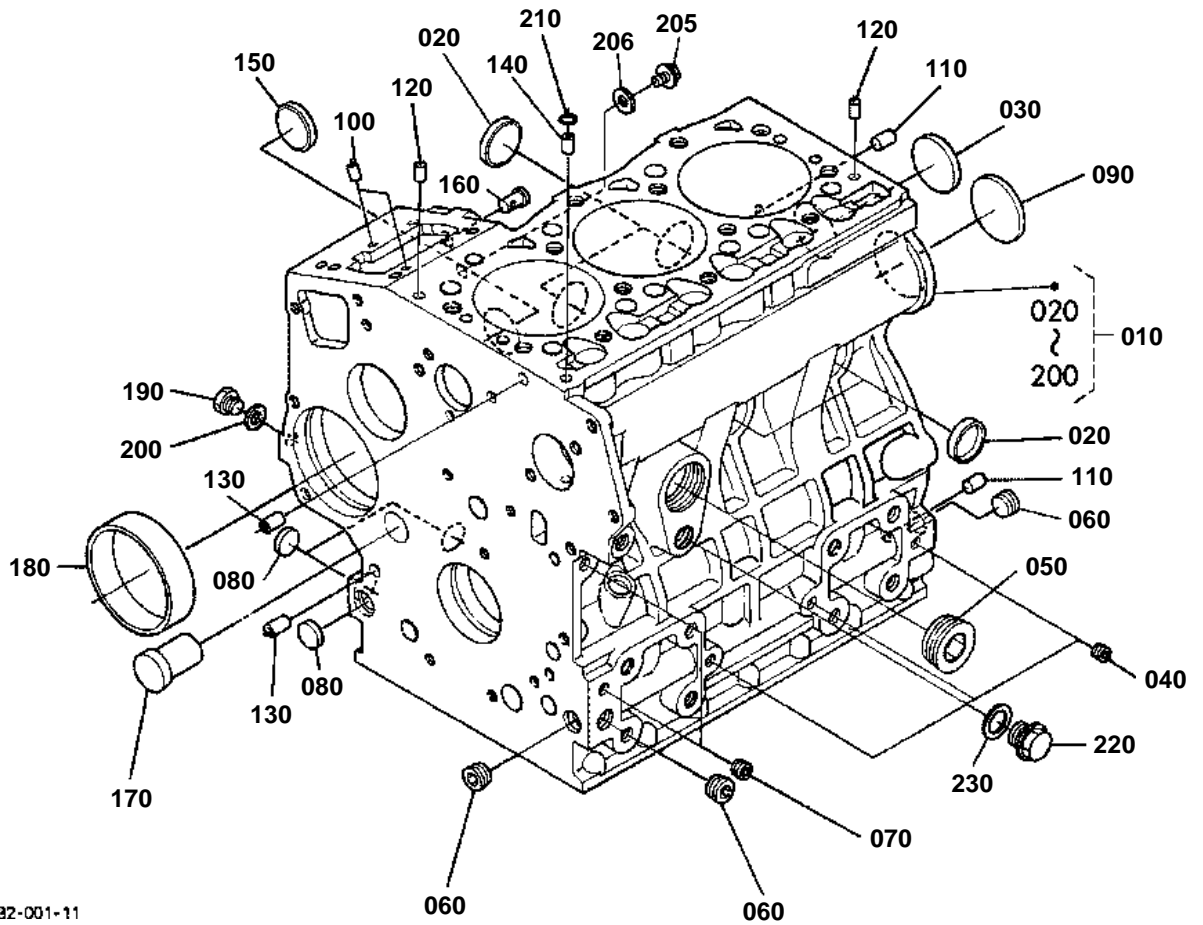

1G032-001-11

**CRANKCASE**

↔ Interchangeable; ≠ not interchangeable; ← new for old; → old for new

REF.No	Part No.	Description	Q'ty	S.No.	I/C	REMARKS	Weight (kgf)	Weight (lb)
010	16611-01017	COMP.CRANKCASE	1				32	70.4
020	15451-96270	CAP SEALING	4				0.012	0.0264
030	15221-03490	CAP SEALING	1				0.02	0.044
040	15261-96010	PLUG	3				0.002	0.0044
050	16683-96020	PLUG	1				0.47	1.034
060	16241-96010	PLUG	3				0.007	0.0154
070	15521-96020	PLUG	2				0.003	0.0066
080	17391-96160	PLUG EXPANSION	3				0.003	0.0066
090	16271-96160	PLUG EXPANSION	1				0.025	0.055
100	05012-00508	PIN STRAIGHT	2				0.001	0.0022
110	16221-94530	PIN STRAIGHT	2			OLD PARTS	0.006	0.0132
110	05012-00814	PIN STRAIGHT	2		≠	NEW PARTS	0.006	0.0132
120	16221-94520	PIN STRAIGHT	2				0.005	0.011
130	15231-33960	PIN PIPE	2				0.001	0.0022
140	16241-33650	PIN PIPE	1				0.002	0.0044
150	16241-96262	PLUG FUEL CAMSHAFT	1				0.007	0.0154
160	16261-56280	PIN START SPRING	1				0.004	0.0088
170	16282-96010	PLUG	1				0.09	0.198
180	16271-55350	BUSH GOVERNOR GEAR	1				0.06	0.132
190	15221-33610	PLUG	1				0.009	0.0198
190	15469-33610	PLUG	1		↔		0.01	0.022
200	15021-33660	GASKET	1				0.001	0.0022
205	01754-50610	BOLT FLANGE	1				0.006	0.0132
206	15601-96650	GASKET	1				0.001	0.0022
210	15221-33700	O RING	1				0.001	0.0022
220	06311-55020	PLUG	1				0.031	0.0682
230	04724-00130	GASKET	1				0.003	0.0066

# OIL PAN

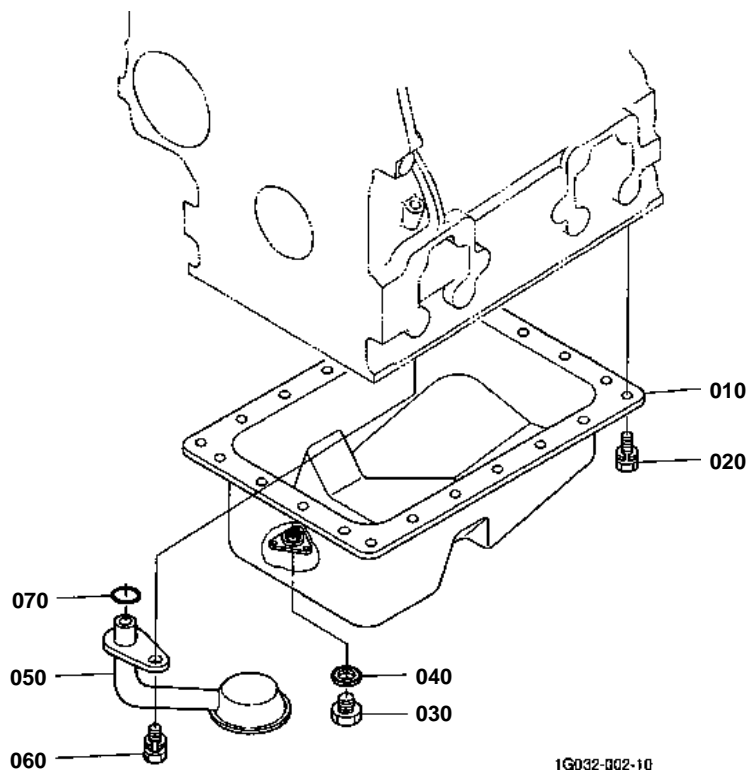





# OIL PAN

↔ Interchangeable; ≠ not interchangeable; ← new for old; → old for new

REF.No	Part No.	Description	Q'ty	S.No.	I/C	REMARKS	Weight (kgf)	Weight (lb)
010	K2561-86110	COMP.OIL PAN	1				0.93	2.046
020	16221-91120	BOLT	22				0.005	0.011
030	15221-33750	PLUG	1				0.032	0.0704
040	6C090-58960	GASKET	1				0.002	0.0044
050	16385-32110	FILTER OIL	1				0.11	0.242
060	01123-60816	BOLT	1				0.01	0.022
070	04814-00160	O RING	1				0.001	0.0022

# CYLINDER HEAD

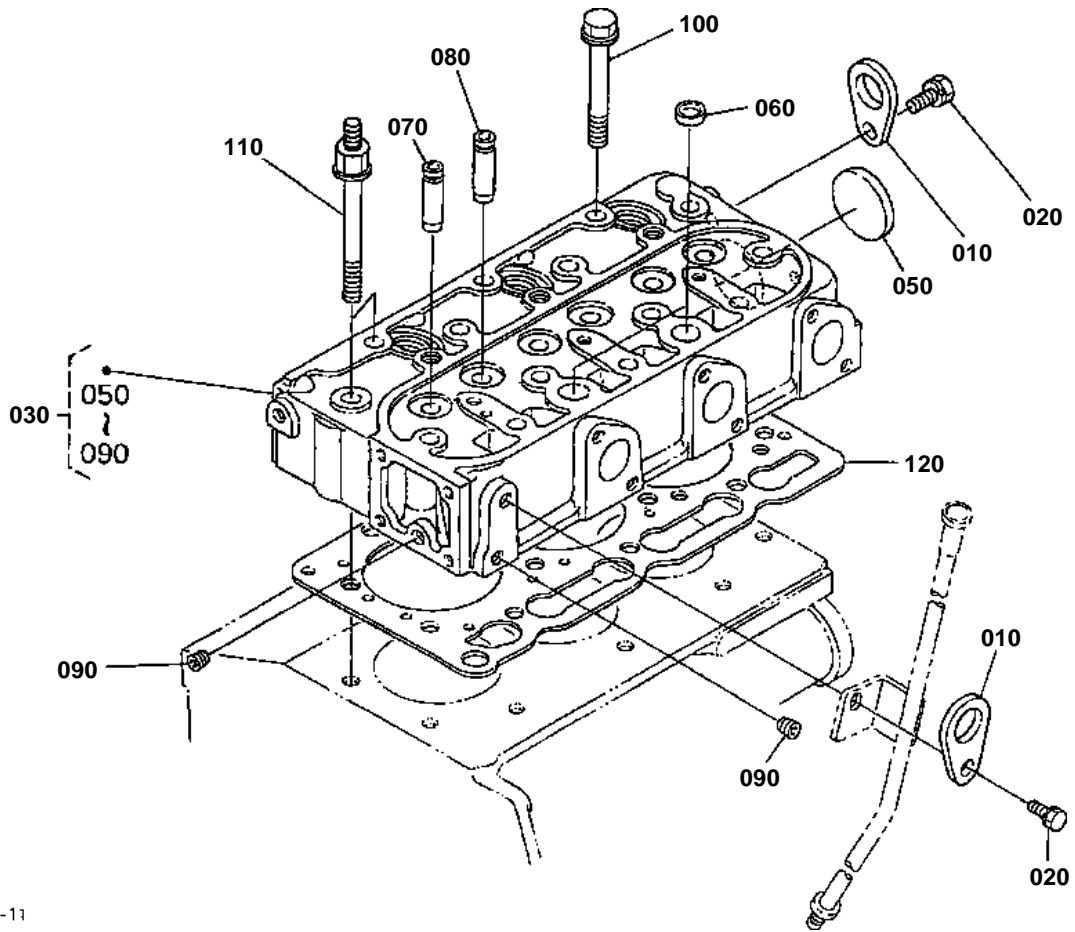

1G032-003-11



## CYLINDER HEAD

↔ Interchangeable; ≠ not interchangeable; ← new for old; → old for new

REF.No	Part No.	Description	Q'ty	S.No.	I/C	REMARKS	Weight (kgf)	Weight (lb)
010	15221-01750	HOOK ENGINE	2				0.04	0.088
020	01123-60814	BOLT	2				0.01	0.022
030	16022-03040	COMP.CYLINDER HEAD	1				10.1	22.22
040	99999-99999	BLANK	0				0	0
050	15321-96260	CAP SEALING	1				0.014	0.0308
060	15261-03370	CAP SEALING	2				0.005	0.011
070	16261-13540	GUIDE INLET VALVE	3				0	0
080	16261-13560	GUIDE EXHAUST VALVE	3				0	0
090	15261-96010	PLUG	2				0.002	0.0044
100	16241-03450	BOLT CYLINDER HEAD	12				0.07	0.154
110	16216-03450	BOLT CYLINDER HEAD	2				0.07	0.154
120	16221-03310	GASKET CYLINDER HEAD	1				0.075	0.165

# GEAR CASE

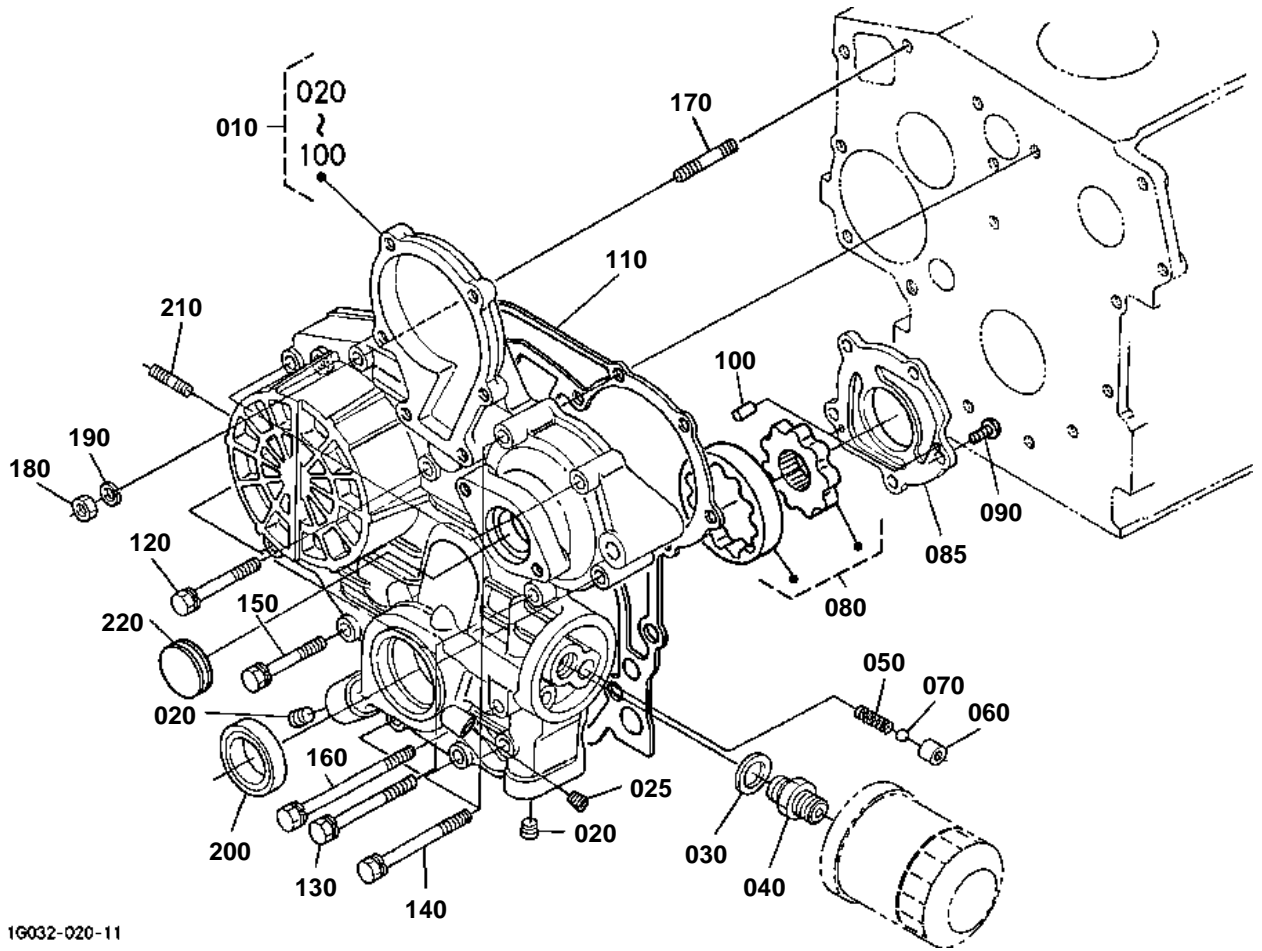

16032-020-11



## GEAR CASE

↔ Interchangeable; ≠ not interchangeable; ← new for old; → old for new

REF.No	Part No.	Description	Q'ty	S.No.	I/C	REMARKS	Weight (kgf)	Weight (lb)
010	16216-04026	COMP.CASE GEAR	1				2.45	5.39
020	16241-96020	PLUG	2				0.015	0.033
025	15521-96020	PLUG	1				0.003	0.0066
030	04011-50180	WASHER PLAIN	1				0.012	0.0264
040	15241-32290	JOINT PIPE	1				0.053	0.1166
050	16241-36950	SPRING	1				0.015	0.033
060	16241-36930	SEAT VALVE	1				0.012	0.0264
070	07715-00201	BALL	1				0.008	0.0176
080	16241-35070	ASSY ROTOR OIL PUMP	1				0.27	0.594
085	16251-35130	COVER OIL PUMP	1				0.09	0.198
090	03017-50620	SCREW CR-REC-BD-HD	5				0.005	0.011
100	05012-00410	PIN STRAIGHT	2				0.001	0.0022
110	16264-04130	GASKET GEAR CASE	1				0.01	0.022
120	01023-50645	BOLT	3				0.01	0.022
130	01023-60650	BOLT	4				0.015	0.033
140	01023-50655	BOLT	4				0.012	0.0264
150	01023-50665	BOLT	1				0.015	0.033
160	16241-91040	BOLT	1				0.015	0.033
170	16245-91530	STUD	1				0.01	0.022
180	02056-50060	NUT	1				0.002	0.0044
190	04512-60060	WASHER SPRING	1				0.001	0.0022
200	16241-04212	SEAL OIL	1				0.012	0.0264
210	16245-91540	STUD	2				0.005	0.011
220	16264-83342	COVER GEAR CASE	1				0.01	0.022

HEAD COVER

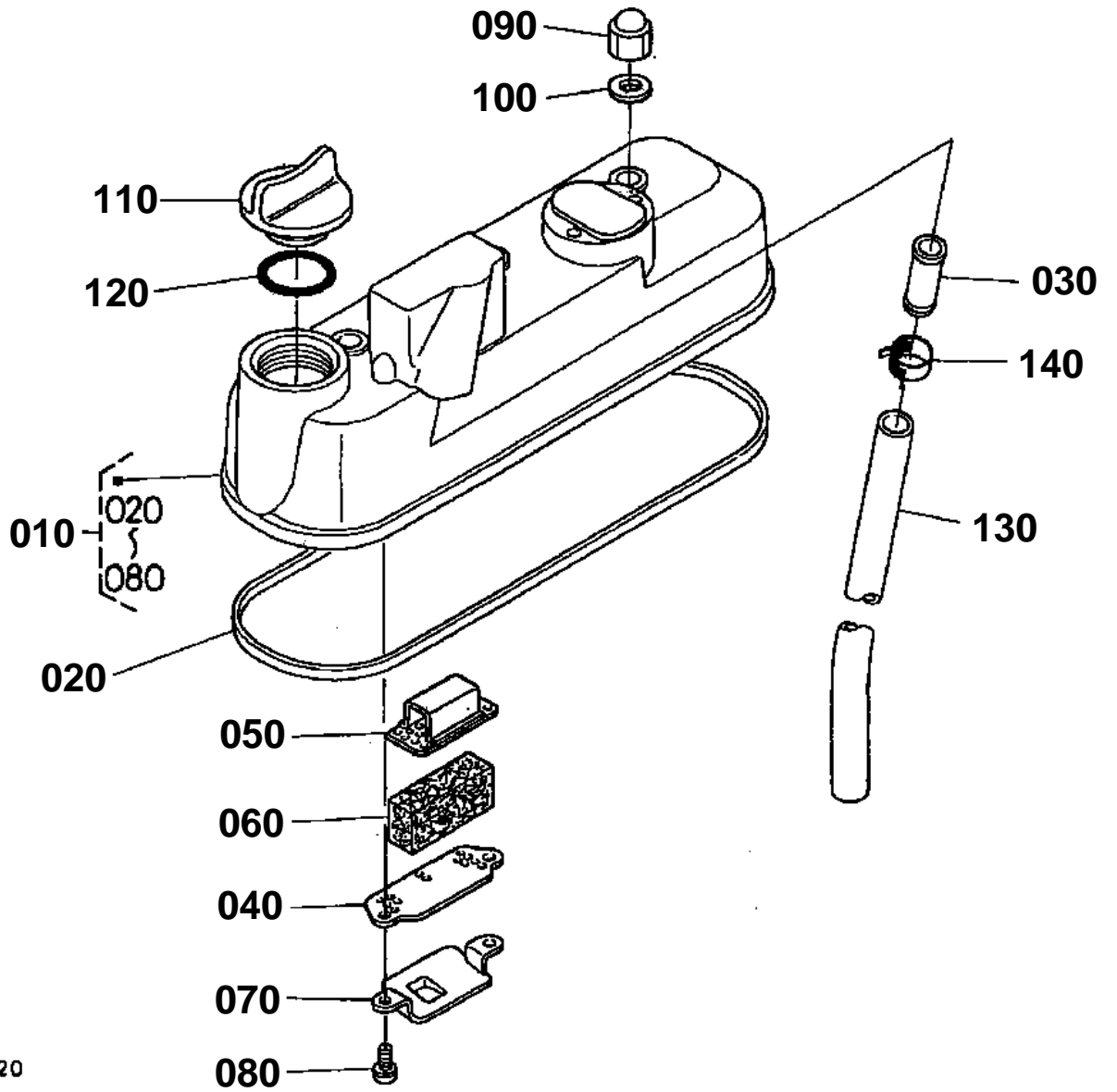

16216-006-20



## HEAD COVER

↔ Interchangeable; ≠ not interchangeable; ← new for old; → old for new

REF.No	Part No.	Description	Q'ty	S.No.	I/C	REMARKS	Weight (kgf)	Weight (lb)
010	16261-14503	ASSY COVER CYL.HEAD	1				0.78	1.716
020	16261-14520	GASKET HEAD COVER	1				0.01	0.022
030	16241-05550	JOINT BREATHER PIPE	1				0.02	0.044
040	16241-05140	PLATE B/THER ELEMENT	1				0.005	0.011
050	16241-05150	PLATE B/THER ELEMENT	1				0.01	0.022
060	16241-05670	ELEMENT BREATHER	1				0.01	0.022
070	16241-05370	OIL SHIELD BREATHER	1				0.01	0.022
080	03024-50510	SCREW WITH WASHER	2				0.002	0.0044
090	15952-92330	NUT	3				0.01	0.022
100	15951-96660	GASKET	3				0.001	0.0022
110	E9151-33140	PLUG OIL FILLER	1				0.017	0.0374
120	04814-50300	O RING	1				0.001	0.0022
130	16271-05510	PIPE BREATHER	1				0.06	0.132
140	16259-05580	CLAMP HOSE	1				0.03	0.066

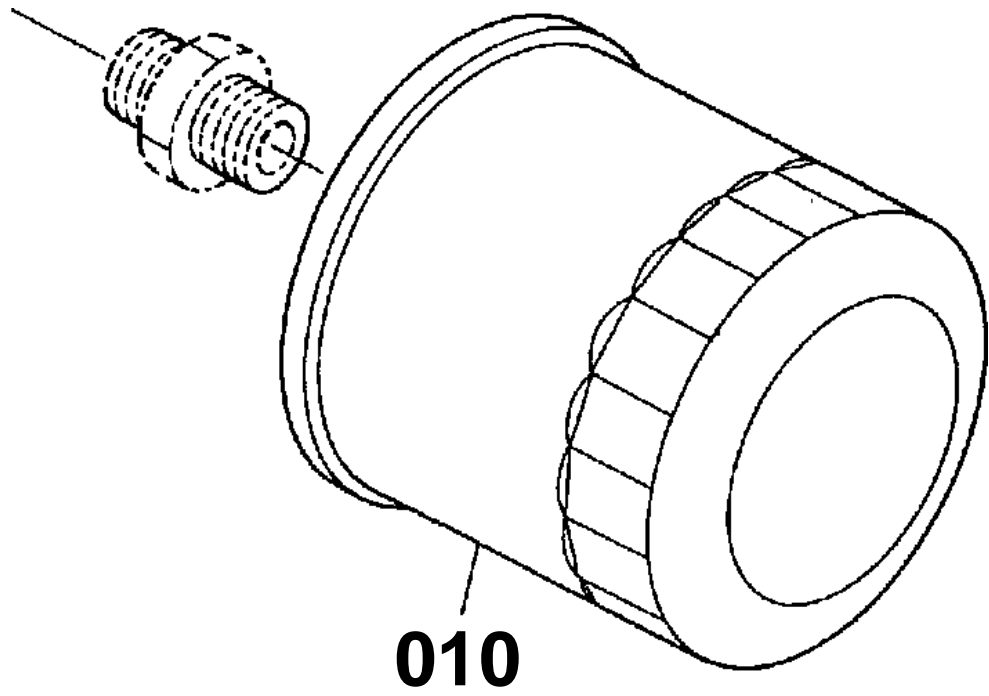

16615-003-10





# OIL FILTER

↔ Interchangeable; ≠ not interchangeable; ← new for old; → old for new

REF.No	Part No.	Description	Q'ty	S.No.	I/C	REMARKS	Weight (kgf)	Weight (lb)
010	15241-32090	ASSY CARTRIDGE OIL	1				0.35	0.77

DIPSTICK AND GUIDE

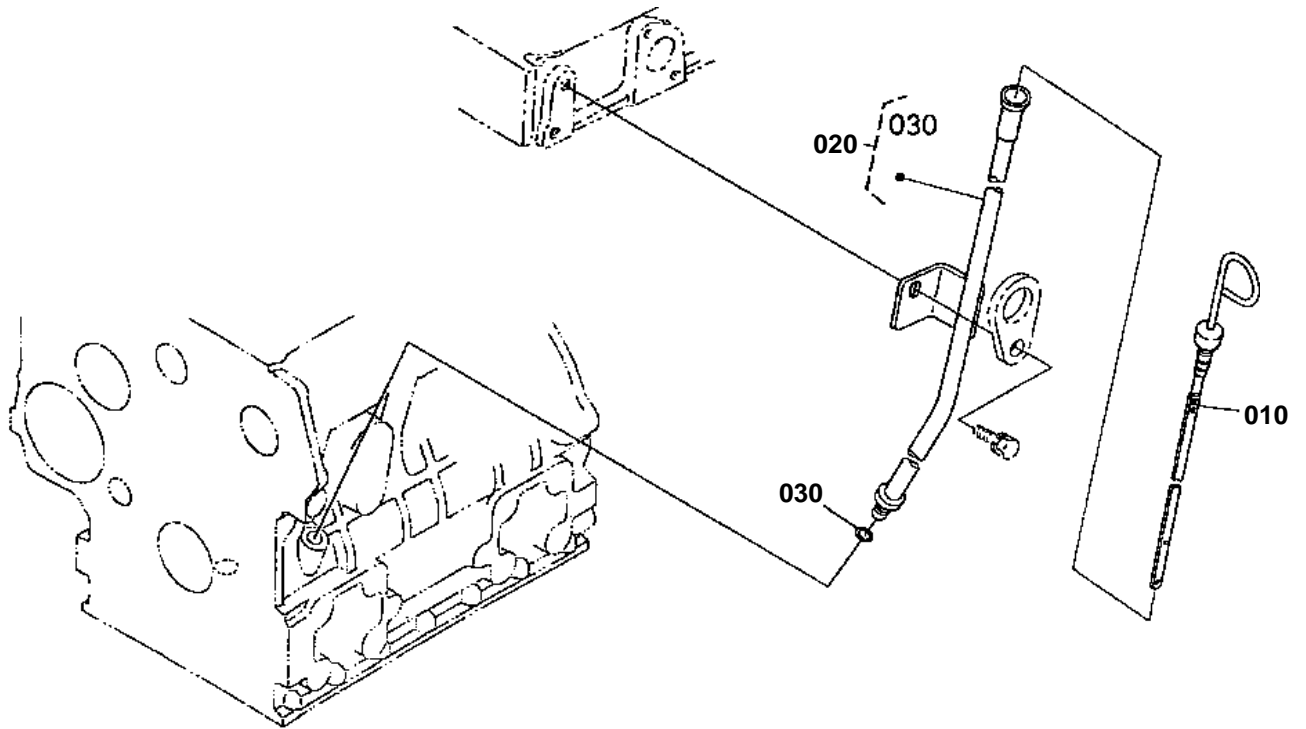

1G032-005-11



## DIPSTICK AND GUIDE

↔ Interchangeable; ≠ not interchangeable; ← new for old; → old for new

REF.No	Part No.	Description	Q'ty	S.No.	I/C	REMARKS	Weight (kgf)	Weight (lb)
010	16204-36413	GAUGE OIL	1				0.03	0.066
020	16282-36500	ASSY GUIDE OIL GAUGE	1				0.11	0.242
030	04814-00090	O RING	1				0.001	0.0022

MAIN BEARING CASE

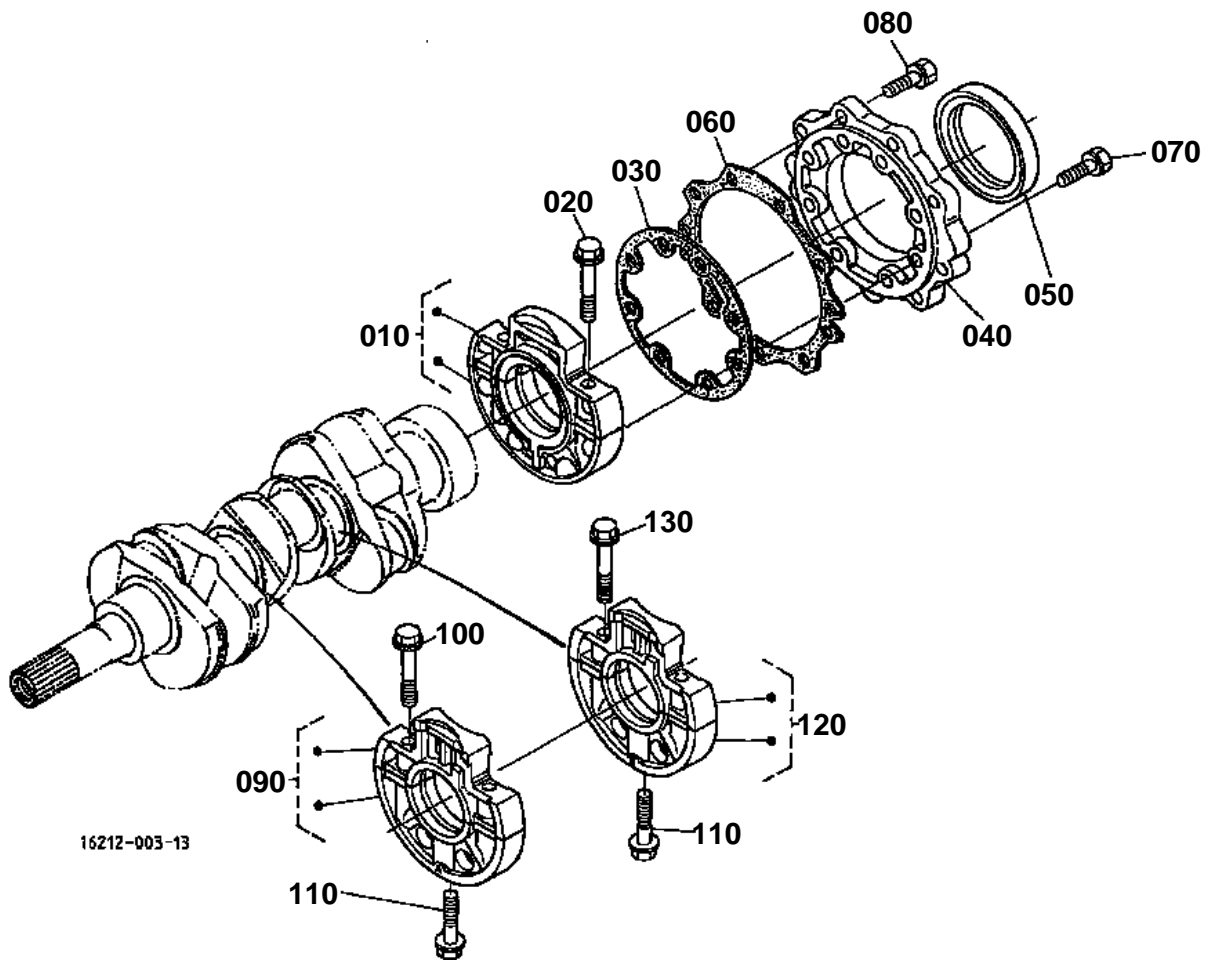



## MAIN BEARING CASE

↔ Interchangeable; ≠ not interchangeable; ← new for old; → old for new

REF.No	Part No.	Description	Q'ty	S.No.	I/C	REMARKS	Weight (kgf)	Weight (lb)
010	16241-04092	ASSY CASE MAIN BRG.	1				1.13	2.486
020	16241-04540	BOLT BEARING CASE	2				0.02	0.044
030	16264-04360	GASKET BRG.CASE	1				0.002	0.0044
040	16241-04813	COVER BEARING CASE	1				0.22	0.484
050	16271-04460	SEAL OIL	1				0.04	0.088
060	16264-04820	GASKET	1				0.008	0.0176
070	01023-50625	BOLT	8				0.007	0.0154
080	01023-50620	BOLT	9				0.006	0.0132
090	16261-04040	ASSY CASE MAIN BRG.	1				0.9	1.98
100	16241-04540	BOLT BEARING CASE	2				0.02	0.044
110	16241-04560	BOLT BEARING CASE	2				0.03	0.066
120	16261-04050	ASSY CASE MAIN BRG.	1				1.11	2.442
130	16241-04540	BOLT BEARING CASE	2				0.02	0.044

CAMSHAFT AND IDLE GEAR SHAFT

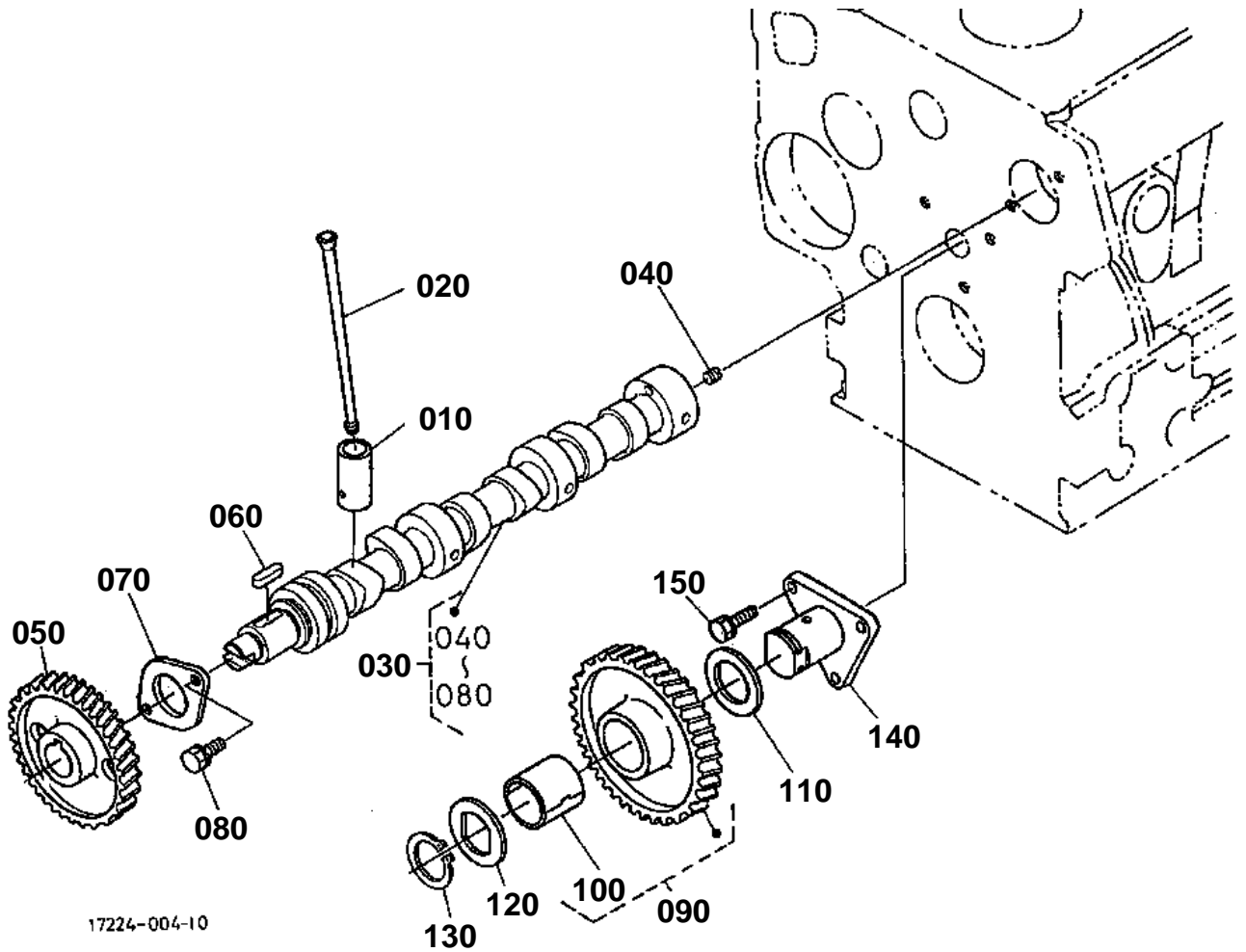



## CAMSHAFT AND IDLE GEAR SHAFT

↔ Interchangeable; ≠ not interchangeable; ← new for old; → old for new

REF.No	Part No.	Description	Q'ty	S.No.	I/C	REMARKS	Weight (kgf)	Weight (lb)
010	16261-15550	TAPPET	6				0.035	0.077
020	16241-15110	PUSH ROD	6				0.03	0.066
030	16261-16010	ASSY CAMSHAFT	1				1.7	3.74
040	15521-93610	SCREW SET	1				0.002	0.0044
050	16241-16510	GEAR CAM	1				0.45	0.99
060	05712-00518	KEY FEATHER	1				0.003	0.0066
070	16241-16270	STOPPER CAMSHAFT	1				0.04	0.088
080	01023-50616	BOLT	2				0.005	0.011
090	16271-24010	COMP GEAR IDLE	1				0.6	1.32
100	16251-24980	BUSH IDLE GEAR	1				0.035	0.077
110	16241-24360	COLLAR IDLE GEAR	1				0.01	0.022
120	16241-24370	COLLAR IDLE GEAR	1				0.012	0.0264
130	16241-24320	CIR CLIP IDLE GEAR	1				0.003	0.0066
140	16241-24250	SHAFT IDLE GEAR	1				0.255	0.561
150	01023-50616	BOLT	3				0.005	0.011

PISTON AND CRANKSHAFT

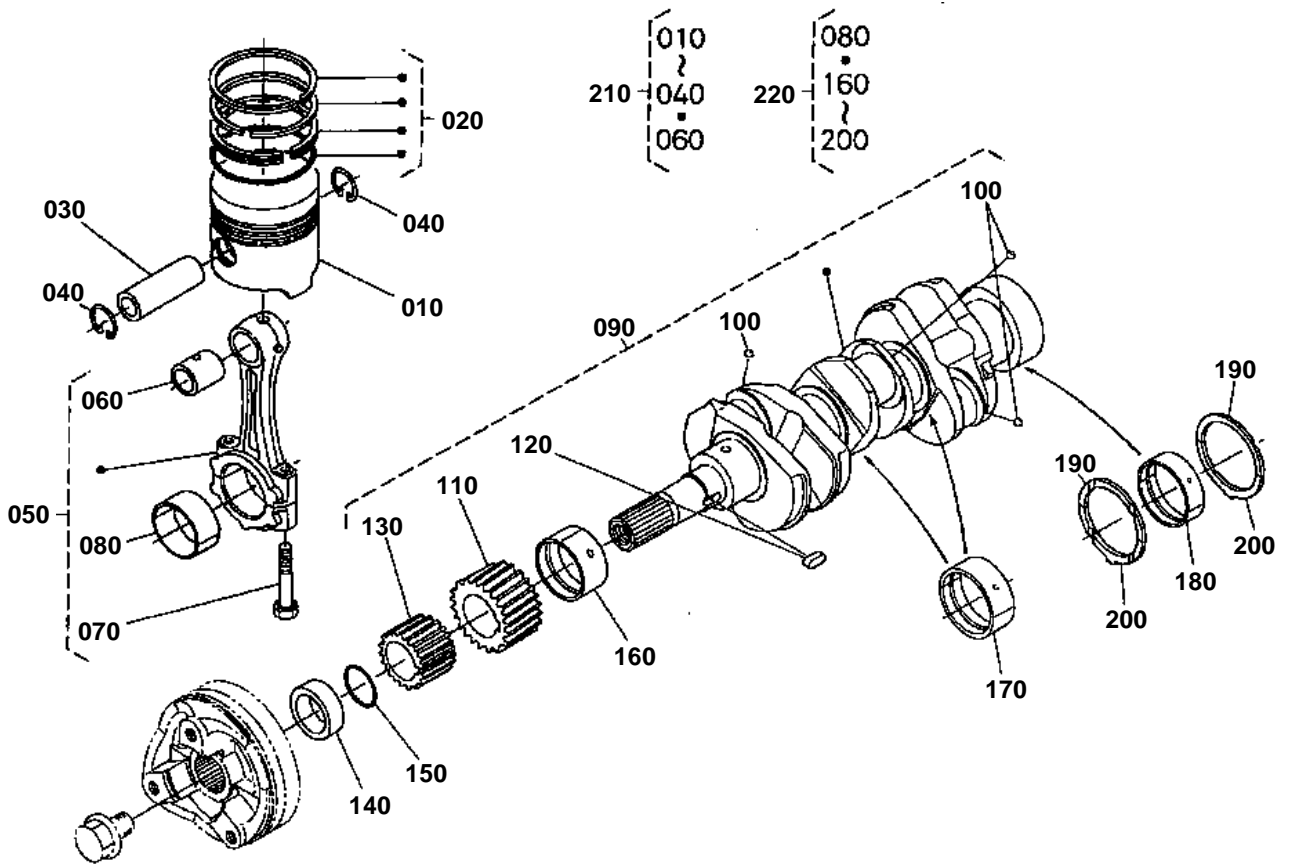

1G032-021-10





# PISTON AND CRANKSHAFT

↔ Interchangeable; ≠ not interchangeable; ← new for old; → old for new

REF.No	Part No.	Description	Q'ty	S.No.	I/C	REMARKS	Weight (kgf)	Weight (lb)
010	16304-21110	PISTON	3			STD	0.335	0.737
010	16304-21910	PISTON	3			+0.50mm	0.27	0.594
020	16304-21050	ASSY PISTON RING	3			STD	0.005	0.011
020	16304-21090	ASSY PISTON RING	3			+0.50mm	0.04	0.088
030	16241-21310	PIN PISTON	3				0.135	0.297
040	16241-21330	CIR CLIP PISTON PIN	6				0.002	0.0044
050	16241-22012	ASSY ROD CONNECTING	3				0.545	1.199
060	16241-21982	BUSH PISTON PIN	3				0.03	0.066
070	16241-22142	BOLT CONNECTING ROD	6				0	0
080	16241-22310	METAL CRANKPIN	3			STD SET	0.038	0.0836
080	16241-22970	METAL CRANKPIN	3			-0.20mm SET	0.08	0.176
080	16241-22980	METAL CRANKPIN	3			-0.40mm SET	0.1	0.22
090	16231-23013	COMP.CRANKSHAFT	1				8.5	18.7
100	07715-00401	BALL	3				0.001	0.0022
110	16241-24110	GEAR CRANK	1				0.15	0.33
120	16271-95230	KEY	1				0.005	0.011
130	16241-35630	GEAR OIL PUMP DRIVE	1				0.102	0.2244
140	16271-23250	COLLAR CRANKSHAFT	1				0.055	0.121
150	04814-10280	O RING	1				0.001	0.0022
160	16241-23470	METAL CRANKSHAFT	1			STD	0.06	0.132
160	16241-23910	METAL CRANKSHAFT	1			-0.20mm	0.03	0.066
160	16241-23920	METAL CRANKSHAFT	1			-0.40mm	0.068	0.1496
170	16241-23480	METAL CRANKSHAFT	2			STD SET	0.05	0.11
170	16241-23930	METAL CRANKSHAFT	2			-0.20mm SET	0.1	0.22
170	16241-23940	METAL CRANKSHAFT	2			-0.40mm SET	0.05	0.11
180	16292-23490	METAL CRANKSHAFT	1			STD SET	0.07	0.154
180	16292-23860	METAL CRANKSHAFT	1			-0.20mm SET	0.05	0.11
180	16292-23870	METAL CRANKSHAFT	1			-0.40mm SET	0.05	0.11
190	15521-23530	METAL SIDE	2			STD	0.01	0.022
190	15521-23950	METAL SIDE	2			+0.20mm	0.01	0.022
190	15521-23960	METAL SIDE	2			+0.40mm	0.01	0.022
200	19202-23540	METAL SIDE	2			STD	0.01	0.022
200	19202-23970	METAL SIDE	2			+0.20mm	0.01	0.022
200	19202-23980	METAL SIDE	2			+0.40mm	0.01	0.022
210	1G032-21770	KIT PISTON-RING	3			STD	0	0
210	1G032-21790	KIT PISTON-RING	3			+0.50mm	0	0
220	1G069-23750	KIT METAL ENGINE	1			STD	0	0
220	1G069-23760	KIT METAL ENGINE	1			-0.20mm/+0.20mm	0	0
220	1G069-23770	KIT METAL ENGINE	1			-0.40mm/+0.40mm	0	0

FLYWHEEL

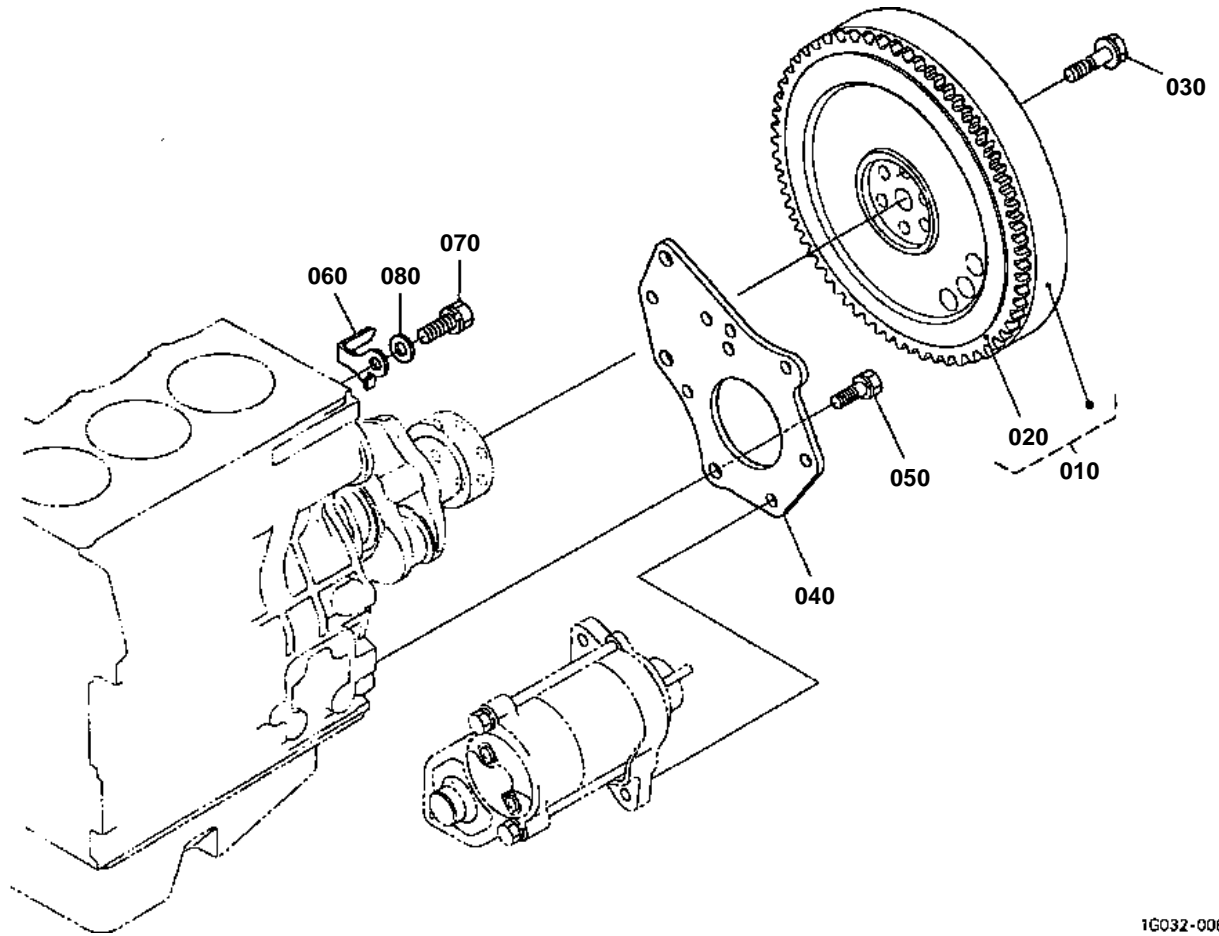

1G032-006-11

**FLYWHEEL**

↔ Interchangeable; ≠ not interchangeable; ← new for old; → old for new

REF.No	Part No.	Description	Q'ty	S.No.	I/C	REMARKS	Weight (kgf)	Weight (lb)
010	1G032-25010	COMP.FLYWHEEL	1				14.7	32.34
020	16813-63820	GEAR RING	1				0.62	1.364
030	16241-25160	BOLT FLYWHEEL	6				0.03	0.066
040	K2561-86310	PLATE STARTER	1				0.64	1.408
050	15261-91190	BOLT	3				0.03	0.066
060	16285-04670	PLATE TIMING	1				0.012	0.0264
070	16271-91190	BOLT	1				0.02	0.044
080	04015-50100	WASHER PLAIN	1				0.016	0.0352

FUEL CAMSHAFT AND GOVERNOR SHAFT

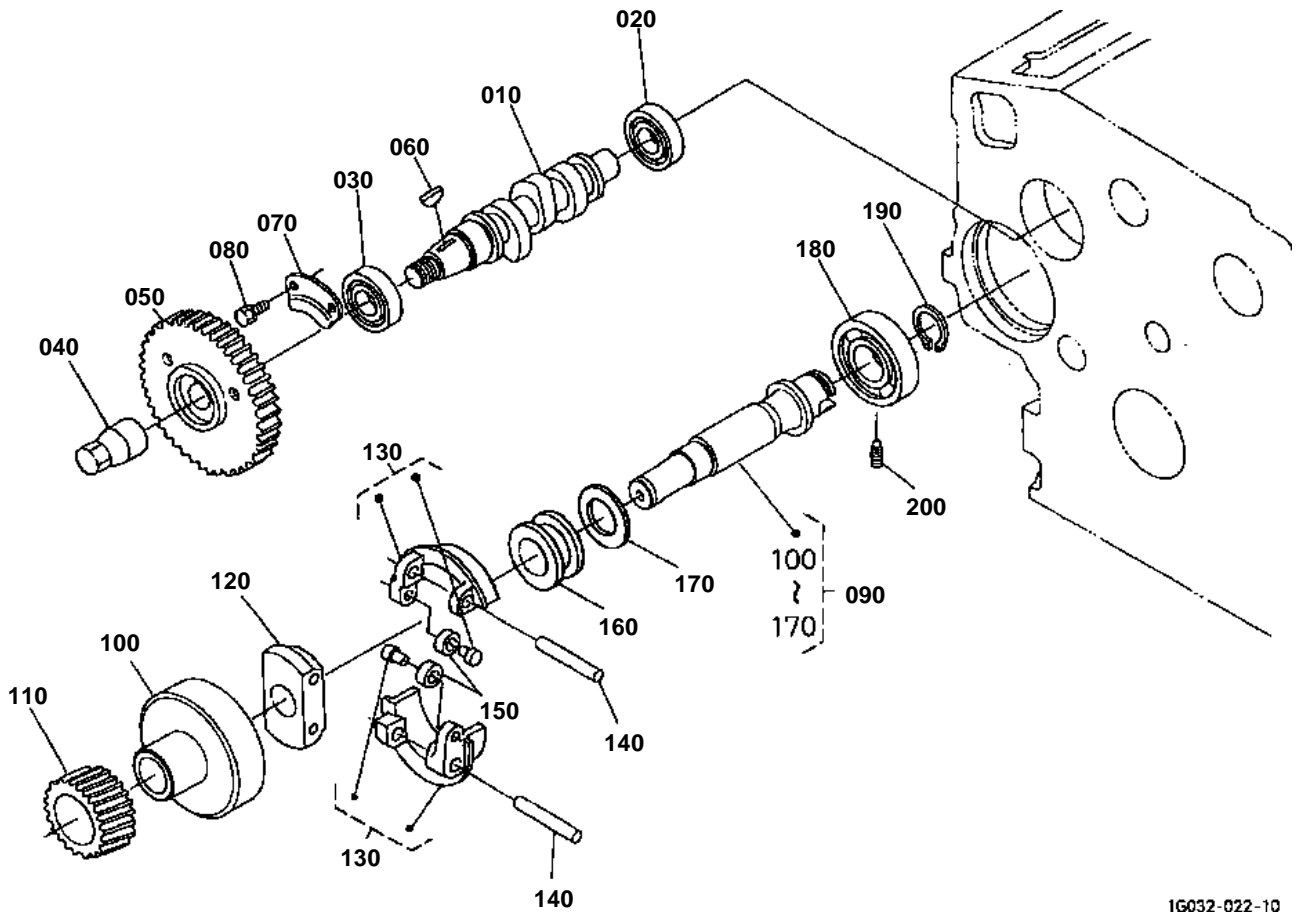

1G032-022-10



## FUEL CAMSHAFT AND GOVERNOR SHAFT

↔ Interchangeable; ≠ not interchangeable; ← new for old; → old for new

REF.No	Part No.	Description	Q'ty	S.No.	I/C	REMARKS	Weight (kgf)	Weight (lb)
010	16020-16170	CAMSHAFT FUEL	1				0.38	0.836
020	16261-97300	BEARING BALL	1				0.044	0.0968
030	08153-06204	BEARING BALL	1				0.11	0.242
040	16241-92330	NUT	1				0.035	0.077
050	17538-51150	GEAR INJECTION PUMP	1				0.5	1.1
060	16241-95230	KEY WOODRUFF	1				0.001	0.0022
070	16241-16320	STOPPER FUEL.C/SHAFT	1				0.04	0.088
080	01023-50616	BOLT	2				0.005	0.011
090	16265-55013	ASSY SHAFT GOVERNOR	1				1.22	2.684
100	16241-55392	HOLDER GOVERNOR GEAR	1				0.34	0.748
110	16282-55320	GEAR GOVERNOR	1				0.24	0.528
120	16241-55270	HOLDER GOV.WEIGHT	1				0.085	0.187
130	16241-55062	COMP.WEIGHT GOVERNOR	2				0.085	0.187
140	16241-55260	SHAFT GOV. WEIGHT	2				0.013	0.0286
150	19484-55440	ROLLER	2				0.005	0.011
160	16241-55450	SLEEVE GOVERNOR	1				0.04	0.088
170	16241-55463	WASHER THRUST	1				0.005	0.011
180	16261-97320	BEARING BALL	1				0.14	0.308
190	16271-55410	CIR CLIP GOV.SHAFT	1				0.005	0.011
200	16241-55554	SCREW SET	1				0.007	0.0154

IDLE APPARATUS

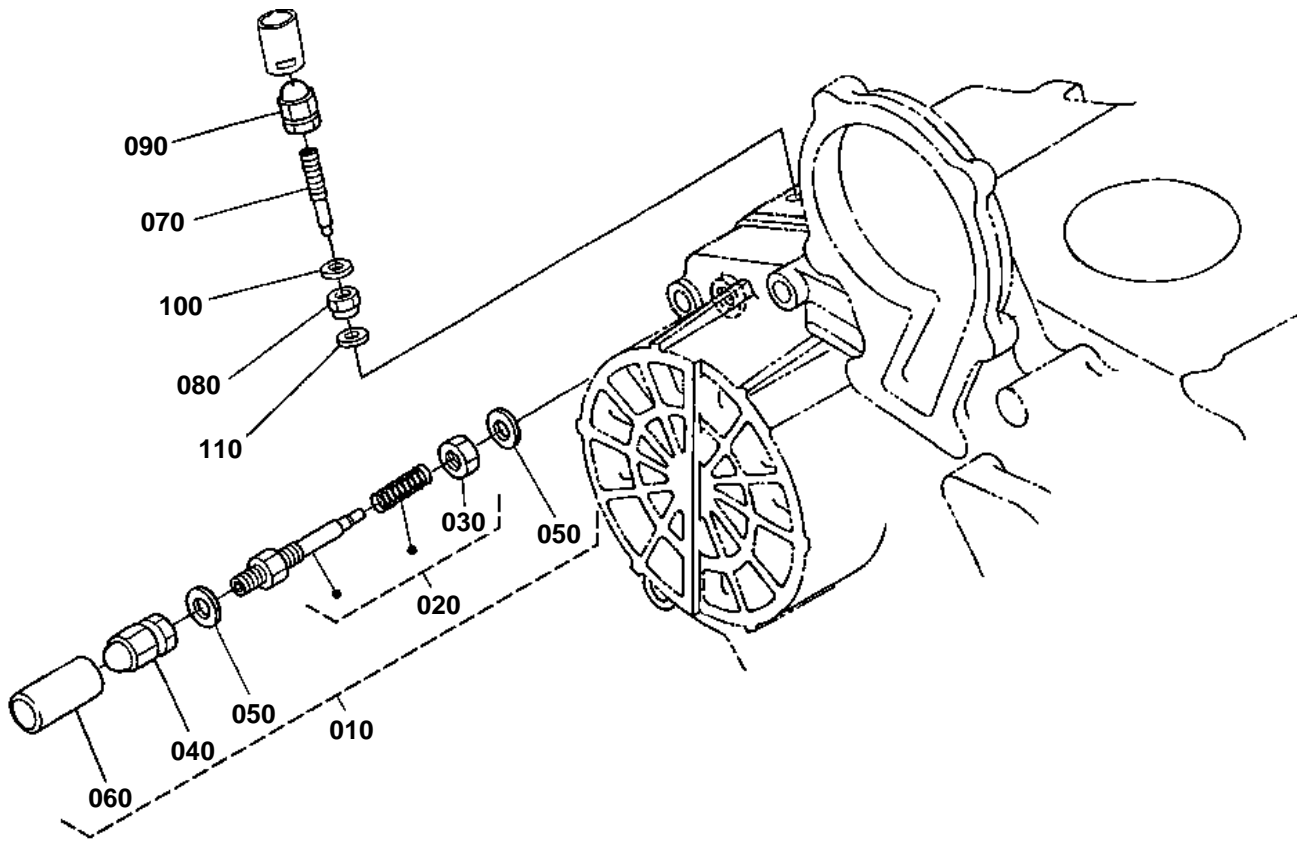

K2591-109-10

# OLD PARTS

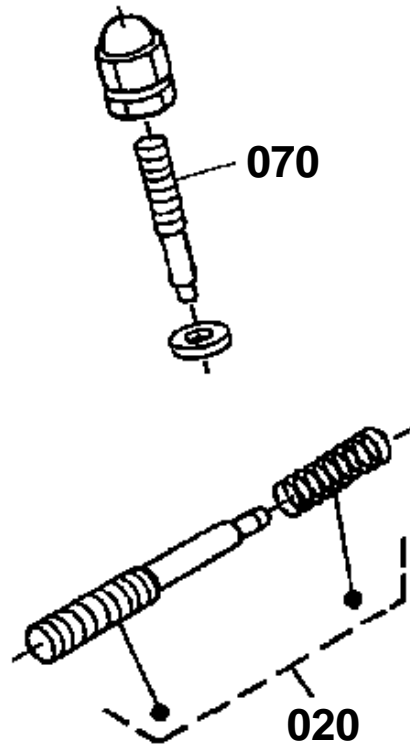

K2591-844-10



# IDLE APPARATUS

↔ Interchangeable; ≠ not interchangeable; ← new for old; → old for new

REF.No	Part No.	Description	Q'ty	S.No.	I/C	REMARKS	Weight (kgf)	Weight (lb)
010	16271-54090	APPARATUS FUEL LIMIT	1			OLD PARTS	0.029	0.0638
010	16271-54093	APPARATUS IDLING	1		←	NEW PARTS	0.029	0.0638
020	16241-54102	ASSY BOLT ADJUSTING	1			OLD PARTS	0.008	0.0176
020	16241-54103	ASSY BOLT ADJUSTMENT	1		←	NEW PARTS	0.008	0.0176
030	15841-92020	NUT	1				0.004	0.0088
040	15841-92330	NUT	1				0.006	0.0132
050	15601-96650	GASKET	2				0.001	0.0022
060	16221-54420	CAP	1				0.001	0.0022
070	16241-54120	BOLT ADJUSTING	1			OLD PARTS	0.005	0.011
070	16241-54122	BOLT ADJUSTING	1		←	NEW PARTS	0.005	0.011
080	1G031-54210	NUT LOCK	1				0.003	0.0066
090	15841-92330	NUT	1				0.006	0.0132
100	15601-96650	GASKET	1				0.001	0.0022
110	1G021-96650	GASKET	1				0.001	0.0022



STOP SOLENOID

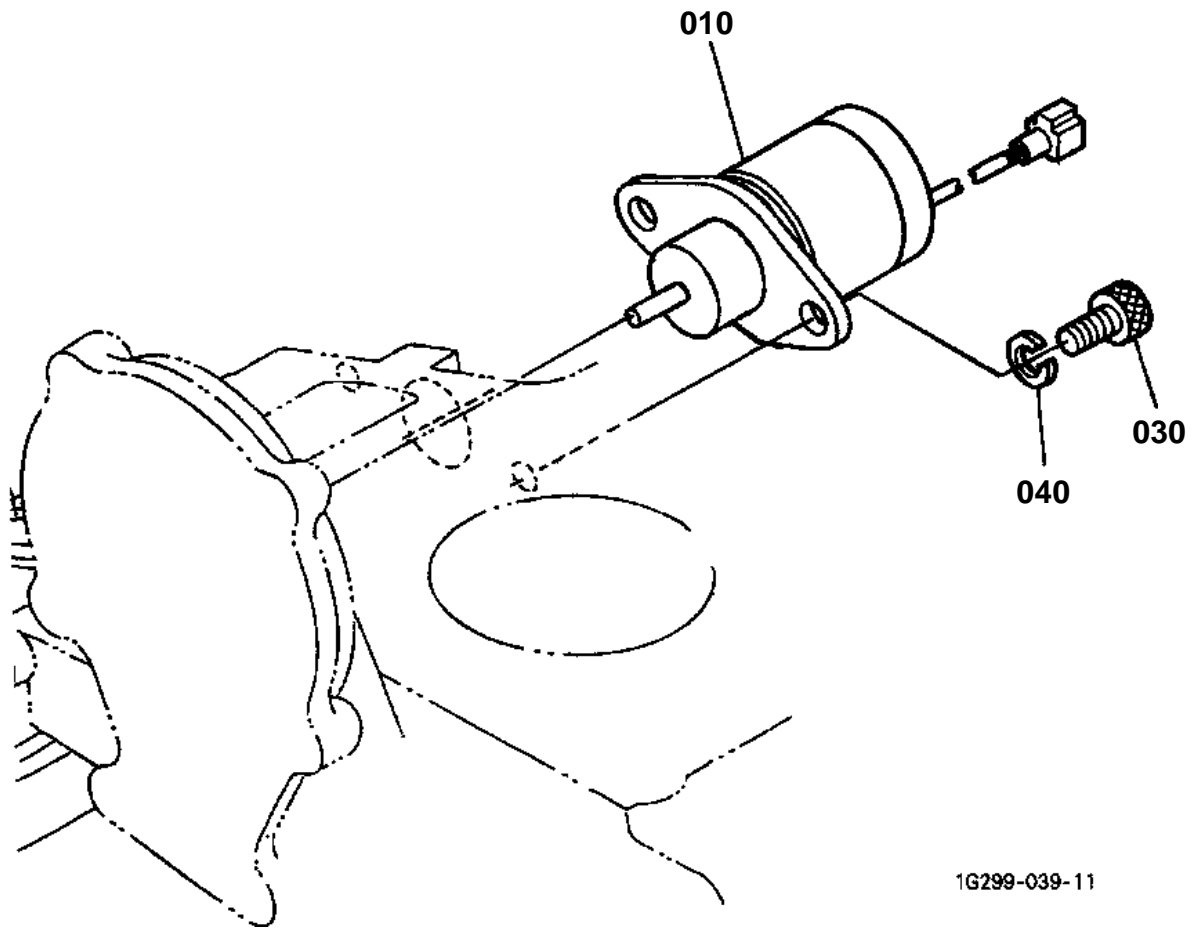

1G299-039-11



# STOP SOLENOID

↔ Interchangeable; ≠ not interchangeable; ← new for old; → old for new

REF.No	Part No.	Description	Q'ty	S.No.	I/C	REMARKS	Weight (kgf)	Weight (lb)
010	16271-60012	ASSY SOLENOID	1				0.35	0.77
020	99999-99999	BLANK	0				0	0
030	01311-10614	BOLT HEX-SOC-HD	2				0.005	0.011
040	04512-60060	WASHER SPRING	2				0.001	0.0022

# INJECTION PUMP

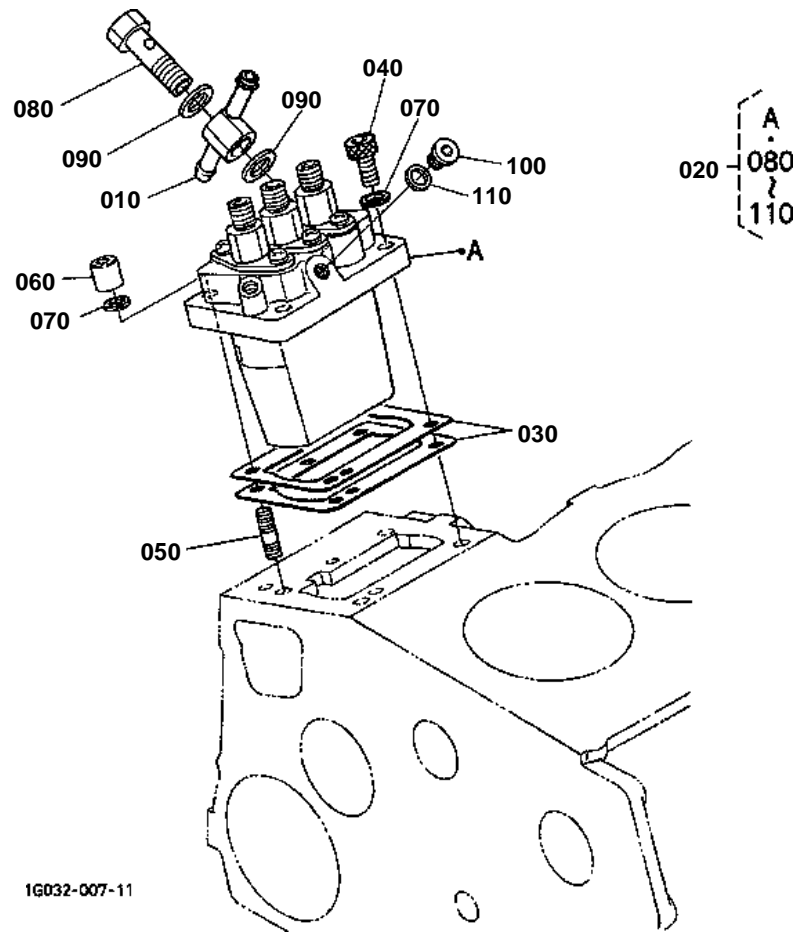



## INJECTION PUMP

↔ Interchangeable; ≠ not interchangeable; ← new for old; → old for new

REF.No	Part No.	Description	Q'ty	S.No.	I/C	REMARKS	Weight (kgf)	Weight (lb)
010	16271-95690	JOINT EYE	1				0.046	0.1012
020	16032-51010	ASSY PUMP INJECTION	1				1	2.2
030	16006-52092	SHIM INJECTION PUMP	1			0.20mm	0.004	0.0088
030	16006-52112	SHIM INJECTION PUMP	1			0.25mm	0.004	0.0088
030	16006-52122	SHIM INJECTION PUMP	1			0.30mm	0.006	0.0132
040	01311-10620	BOLT HEX-SOC-HD	2				0.012	0.0264
050	15841-91500	STUD	2				0.02	0.044
060	15841-92320	NUT	2				0.01	0.022
070	04512-60060	WASHER SPRING	4				0.001	0.0022
080	16271-51320	SCREW FOLLOW	1				0.031	0.0682
090	15841-96650	GASKET	2				0.001	0.0022
100	16030-96010	PLUG	1				0.008	0.0176
110	15861-96650	GASKET	1				0.001	0.0022

GOVERNOR

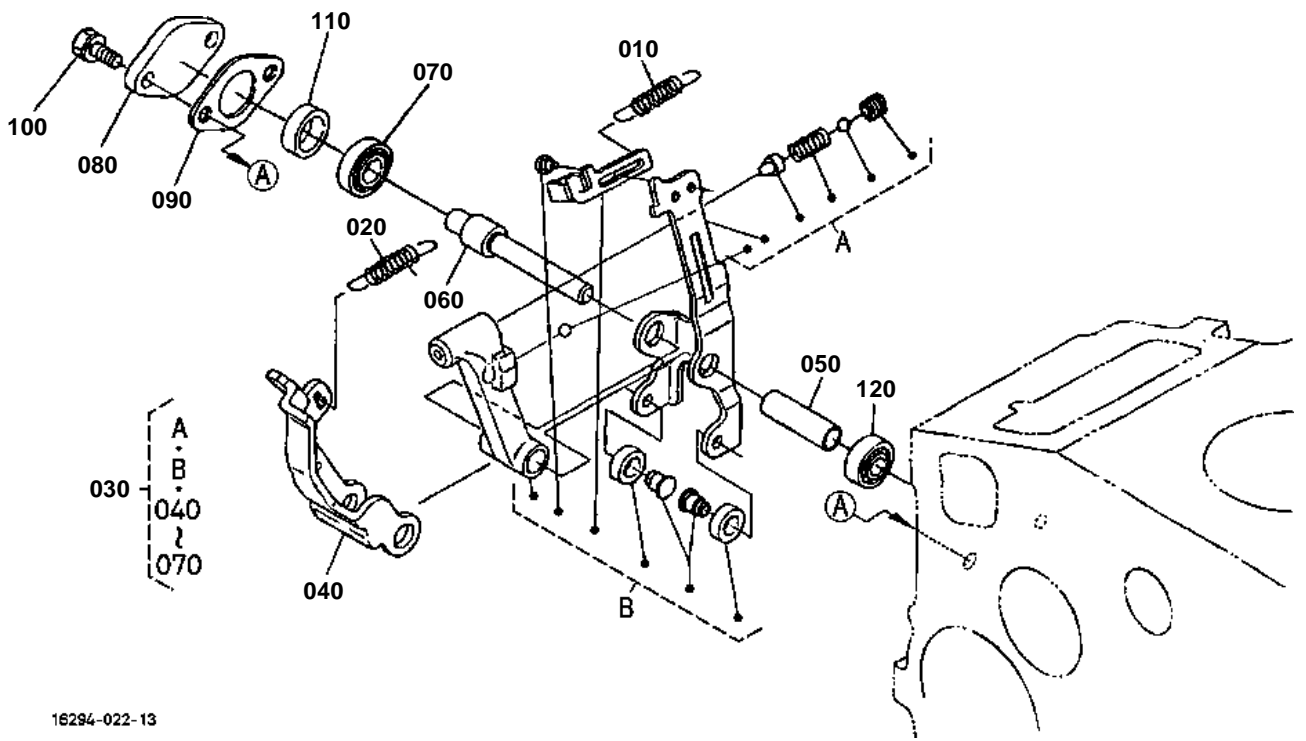

16294-022-13

**GOVERNOR**

↔ Interchangeable; ≠ not interchangeable; ← new for old; → old for new

REF.No	Part No.	Description	Q'ty	S.No.	I/C	REMARKS	Weight (kgf)	Weight (lb)
010	17455-56480	SPRING START	1				0.001	0.0022
020	16285-56412	SPRING GOVERNOR	1				0.022	0.0484
030	1G032-56014	ASSY LEVER FORK	1				0.25	0.55
040	1G032-56130	LEVER FORK	1				0.08	0.176
050	1G032-56150	SHAFT FORK LEVER	1				0.007	0.0154
060	1G032-56470	SHAFT FORK LEVER	1				0.04	0.088
070	16241-56330	BEARING MINIATURIZE	1				0.007	0.0154
080	16241-56250	COVER FORK LEV.SHAFT	1				0.013	0.0286
090	16299-56260	GASKET	1				0.002	0.0044
100	01023-50614	BOLT	2				0.005	0.011
110	16241-56210	COLLAR	1				0.008	0.0176
120	16241-56340	BEARING MINIATURIZE	1				0.007	0.0154

SPEED CONTROL PLATE

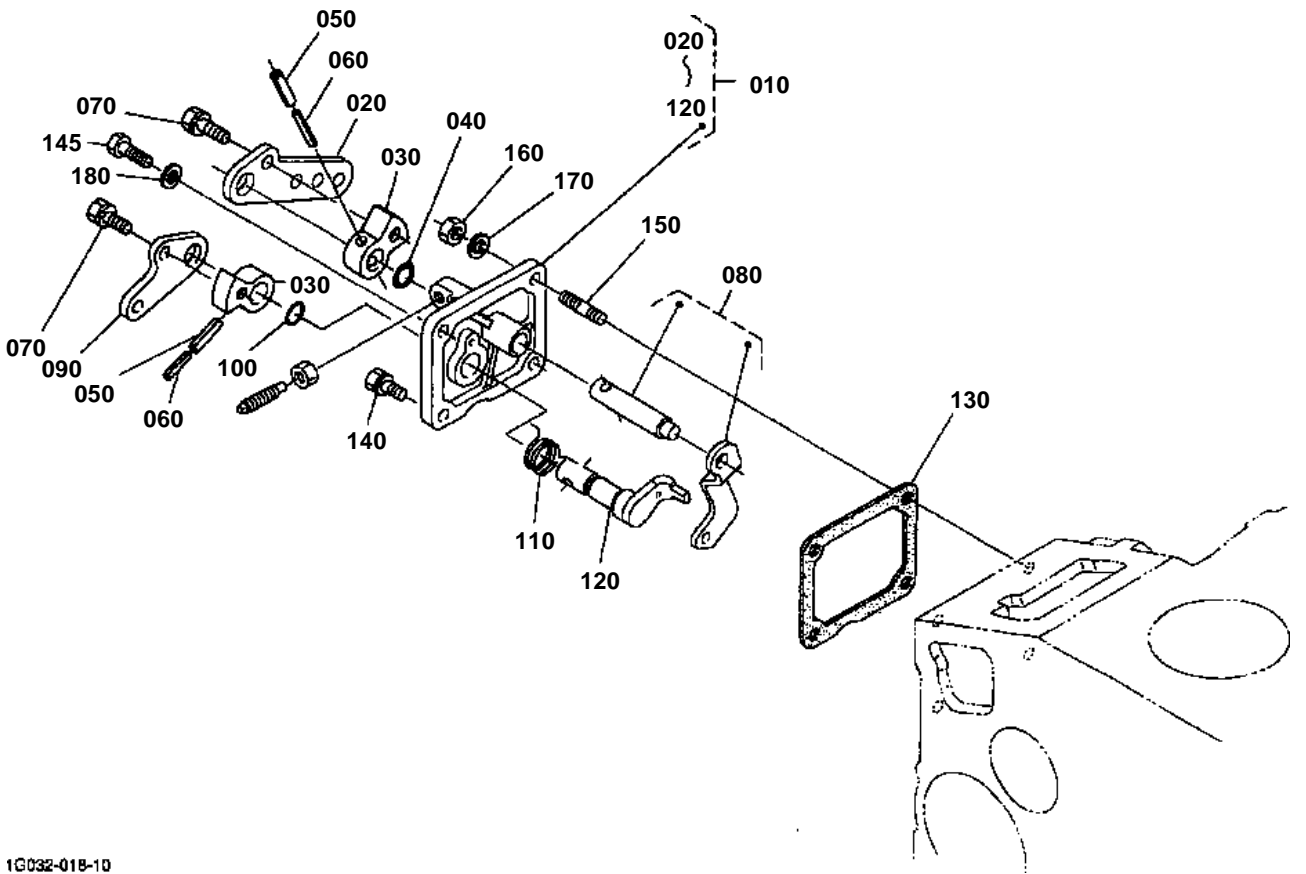

1G032-018-10



## SPEED CONTROL PLATE

↔ Interchangeable; ≠ not interchangeable; ← new for old; → old for new

REF.No	Part No.	Description	Q'ty	S.No.	I/C	REMARKS	Weight (kgf)	Weight (lb)
010	1G032-57010	ASSY PLATE CONTROL	1				0.33	0.726
020	16205-57150	LEVER SPEED CONTROL	1				0.033	0.0726
030	16205-57160	LEVER SPEED CONTROL	2				0.03	0.066
040	04814-00100	O RING	1				0.001	0.0022
050	05411-00420	PIN SPRING	2				0.001	0.0022
060	05411-02520	PIN SPRING	2				0.001	0.0022
070	01023-50612	BOLT	2				0.005	0.011
080	16205-56020	COMP.LEVER GOVERNOR	1				0.02	0.044
090	16234-57720	LEVER ENGINE STOP	1				0.03	0.066
100	04814-10070	O RING	1				0.001	0.0022
110	16205-57510	SPRING RETURN	1				0.002	0.0044
120	16205-57740	COMP.LEVER STOP	1				0.046	0.1012
130	16264-57210	GASKET	1				0.002	0.0044
140	01023-50616	BOLT	1				0.005	0.011
145	01053-50618	BOLT	1				0.006	0.0132
150	16245-91540	STUD	2				0.005	0.011
160	02056-50060	NUT	2				0.002	0.0044
170	04512-60060	WASHER SPRING	2				0.001	0.0022
180	15601-96650	GASKET	1				0.001	0.0022



NOZZLE HOLDER AND GLOW PLUG

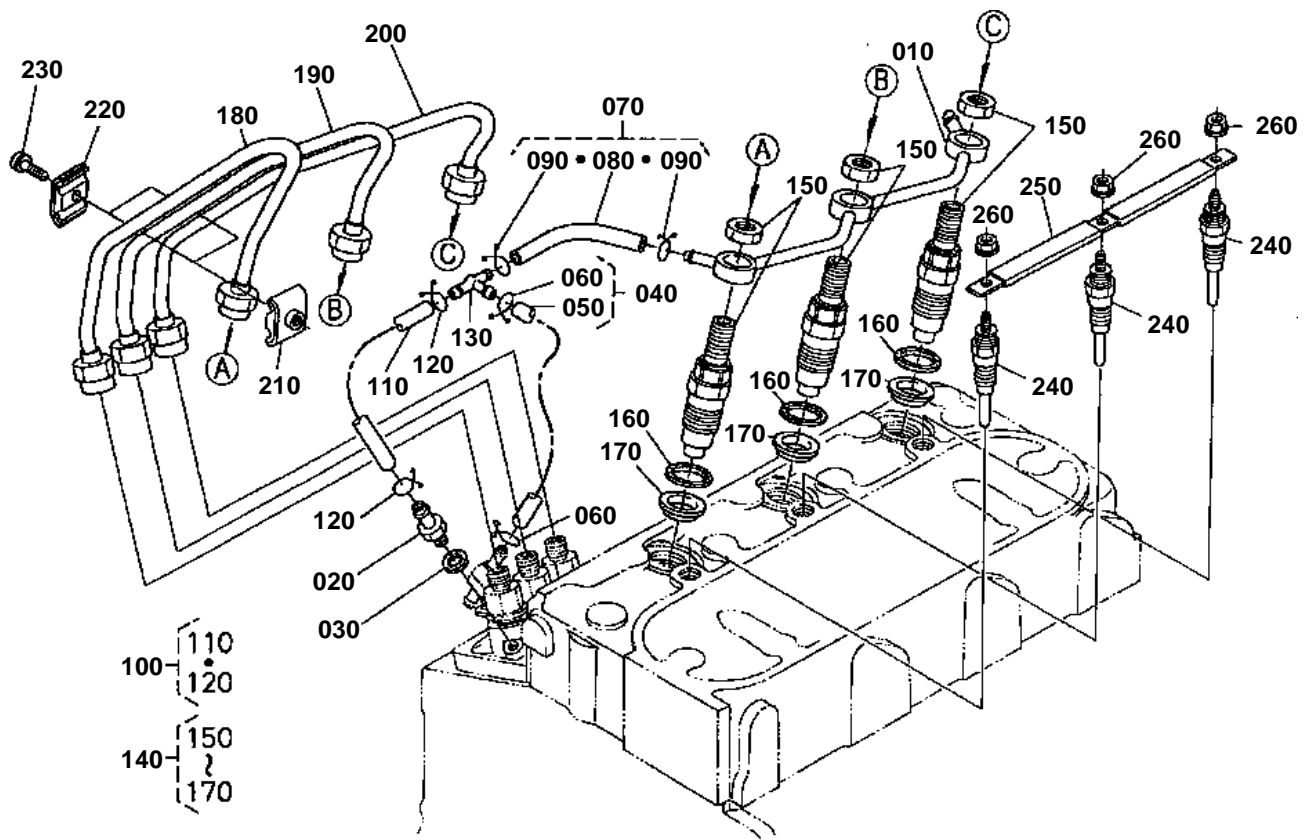

1G032-009-11



## NOZZLE HOLDER AND GLOW PLUG

↔ Interchangeable; ≠ not interchangeable; ← new for old; → old for new

REF.No	Part No.	Description	Q'ty	S.No.	I/C	REMARKS	Weight (kgf)	Weight (lb)
010	16261-42502	ASSY PIPE OVER FLOW	1				0.04	0.088
020	15841-51360	SCREW AIR BREEDER	1				0.008	0.0176
030	15601-96650	GASKET	1				0.001	0.0022
040	17582-42020	ASSY PIPE OVER FLOW	1				0.001	0.0022
050	09661-40120	TUBE FUEL	1				0.005	0.011
060	14971-42750	CLIP PIPE	2				0.001	0.0022
070	16282-42020	ASSY PIPE OVER FLOW	1				0.01	0.022
080	09661-40040	TUBE FUEL	1				0.005	0.011
090	14971-42750	CLIP PIPE	2				0.001	0.0022
100	16264-42030	ASSY PIPE OVER FLOW	1				0.005	0.011
110	09661-40080	TUBE FUEL	1				0.01	0.022
120	14971-42750	CLIP PIPE	2				0.001	0.0022
130	K3511-58390	JOINT T-PIPE	1				0.001	0.0022
140	16032-53900	KIT HOLDER NOZZLE	3				0.16	0.352
150	16032-53000	ASSY HOLDER NOZZLE	3				0.14	0.308
160	15841-53622	GASKET	3				0.002	0.0044
170	19077-53650	SEAL HEAT	3				0.005	0.011
180	16231-53712	PIPE INJECTION	1				0.12	0.264
190	16231-53722	PIPE INJECTION	1				0.12	0.264
200	16231-53732	PIPE INJECTION	1				0.12	0.264
210	15841-53850	CLAMP PIPE	2				0.01	0.022
220	15841-53860	CLAMP PIPE	2				0.009	0.0198
230	03024-50520	SCREW WITH WASHER	2				0.004	0.0088
240	16851-65510	GLOW PLUG	3				0.02	0.044
250	16261-65560	CORD GLOW PLUG	1				0.01	0.022
260	02761-50040	NUT FLANGE	3				0.002	0.0044

NOZZLE HOLDER [COMPONENT PARTS]

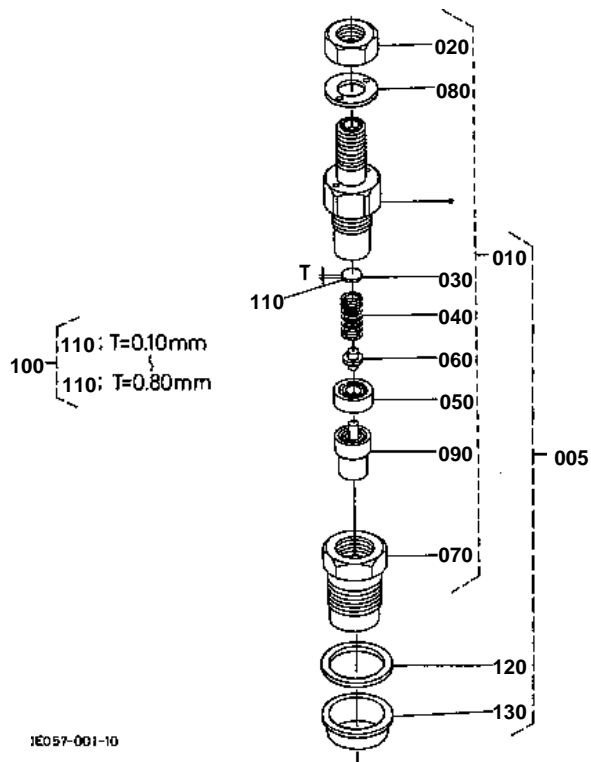



## NOZZLE HOLDER [COMPONENT PARTS]

↔ Interchangeable; ≠ not interchangeable; ← new for old; → old for new

REF.No	Part No.	Description	Q'ty	S.No.	I/C	REMARKS	Weight (kgf)	Weight (lb)
005	16032-53900	KIT HOLDER NOZZLE	3				0.16	0.352
010	16032-53000	ASSY HOLDER NOZZLE	3				0.14	0.308
020	16032-92030	NUT	3				0.007	0.0154
030	16032-53230	WASHER ADJUSTING	3				0.001	0.0022
040	16032-53170	SPRING NOZZLE	3				0.007	0.0154
050	16032-53350	SPACER DISTANCE	3				0.02	0.044
060	16032-53160	PUSH ROD	3				0.001	0.0022
070	16032-53280	NUT NOZZLE	3				0.037	0.0814
080	16032-94040	WASHER PLAIN	3				0.002	0.0044
090	16032-53610	PIECE NOZZLE	3				0.021	0.0462
100	16032-98100	ASSY WASHER ADJUST	3			OPTION	0.016	0.0352
110	16032-98500	WASHER ADJUSTING	3			0.10mm	0.001	0.0022
110	16032-98510	WASHER ADJUSTING	3			0.20mm	0.001	0.0022
110	16032-98520	WASHER ADJUSTING	3			0.30mm	0.001	0.0022
110	16032-98530	WASHER ADJUSTING	3			0.40mm	0.001	0.0022
110	16032-98540	WASHER ADJUSTING	3			0.50mm	0.001	0.0022
110	16032-98550	WASHER ADJUSTING	3			0.52mm	0.001	0.0022
110	16032-98560	WASHER ADJUSTING	3			0.54mm	0.001	0.0022
110	16032-98570	WASHER ADJUSTING	3			0.56mm	0.001	0.0022
110	16032-98580	WASHER ADJUSTING	3			0.58mm	0.001	0.0022
110	16032-98590	WASHER ADJUSTING	3			0.80mm	0.001	0.0022
120	15841-53622	GASKET	3				0.002	0.0044
130	19077-53650	SEAL HEAT	3				0.005	0.011

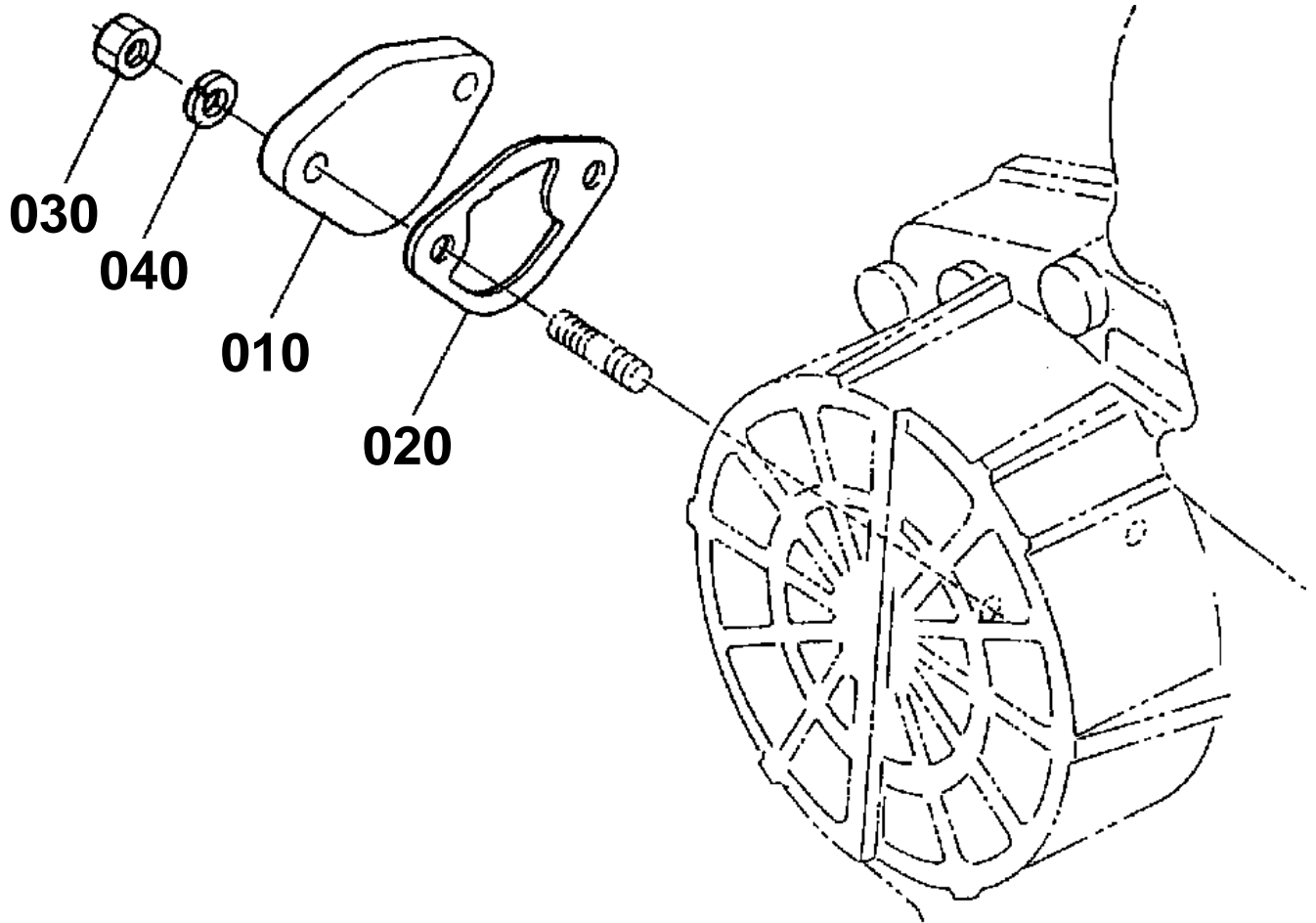

16226-014-10



**COVER**

↔ Interchangeable; ≠ not interchangeable; ← new for old; → old for new

REF.No	Part No.	Description	Q'ty	S.No.	I/C	REMARKS	Weight (kgf)	Weight (lb)
010	15852-52850	COVER	1				0.058	0.1276
020	16264-52140	GASKET FUEL PUMP	1				0.001	0.0022
030	02056-50060	NUT	2				0.002	0.0044
040	04512-60060	WASHER SPRING	2				0.001	0.0022

DYNAMO AND PULLEY

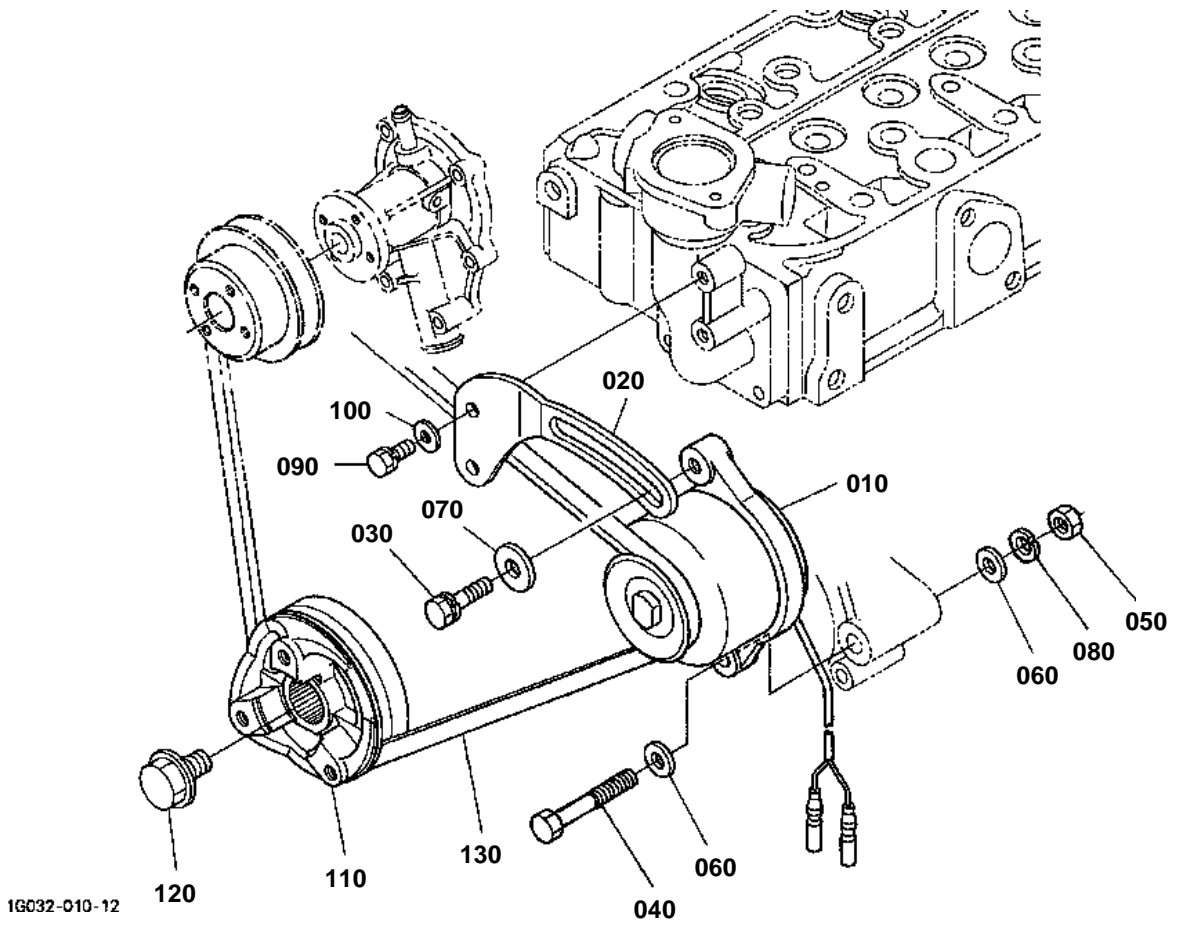



## DYNAMO AND PULLEY

↔ Interchangeable; ≠ not interchangeable; ← new for old; → old for new

REF.No	Part No.	Description	Q'ty	S.No.	I/C	REMARKS	Weight (kgf)	Weight (lb)
010	15531-64016	ASSY DYNAMO	1				1.4	3.08
020	16225-64420	STAY DYNAMO	1				0.084	0.1848
030	01123-50830	BOLT	1				0.015	0.033
040	01153-50860	BOLT	1				0.024	0.0528
050	02112-50080	NUT	1				0.003	0.0066
060	04012-50080	WASHER PLAIN	2				0.001	0.0022
070	04015-60080	WASHER PLAIN	1				0.01	0.022
080	04512-60080	WASHER SPRING	1				0.002	0.0044
090	01023-50618	BOLT	1				0.006	0.0132
100	04012-50060	WASHER PLAIN	1				0.001	0.0022
110	K2561-86210	PULLEY FAN DRIVE	1				1.37	3.014
120	16241-91020	BOLT FAN DRIVE	1				0.1	0.22
130	16241-97010	V BELT	1				0.08	0.176



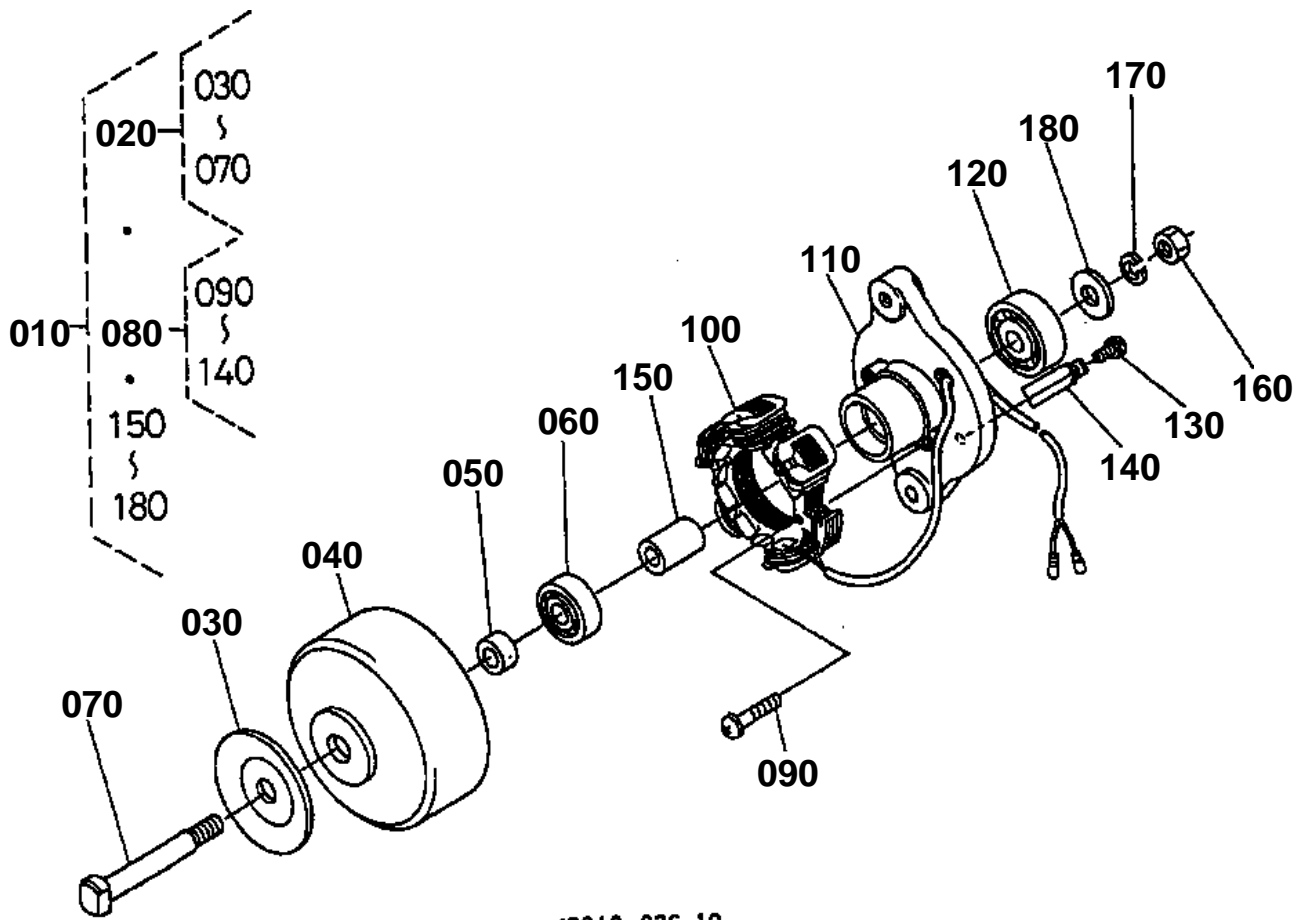

**DYNAMO [COMPONENT PARTS]**

↔ Interchangeable; ≠ not interchangeable; ← new for old; → old for new

REF.No	Part No.	Description	Q'ty	S.No.	I/C	REMARKS	Weight (kgf)	Weight (lb)
010	15531-64016	ASSY DYNAMO	1				1.4	3.08
020	15381-64120	COMP.FLYWHEEL	1				0.67	1.474
030	15531-64110	PULLEY	1				0.15	0.33
040	15381-64040	FLYWHEEL	1				0.48	1.056
050	6C040-82860	COLLAR	1				0.014	0.0308
060	15531-74180	BEARING BALL	1				0.04	0.088
070	15381-74140	SHAFT FAN	1				0.07	0.154
080	15381-64360	COMP.STATOR	1				0.59	1.298
090	15261-93010	SCREW ROUND HEAD	2				0.003	0.0066
100	15381-64290	STATOR	1				0.24	0.528
110	15381-64070	PLATE	1				0.26	0.572
120	15531-74180	BEARING BALL	1				0.04	0.088
130	15531-93010	SCREW ROUND HEAD	1				0.002	0.0044
140	15381-64190	CLAMP CORD	1				0.001	0.0022
150	15381-64150	COLLAR	1				0.025	0.055
160	15261-92030	NUT	1				0.01	0.022
170	15261-94070	WASHER SPRING	1				0.003	0.0066
180	15261-94020	WASHER PLAIN	1				0.007	0.0154

# STARTER

---

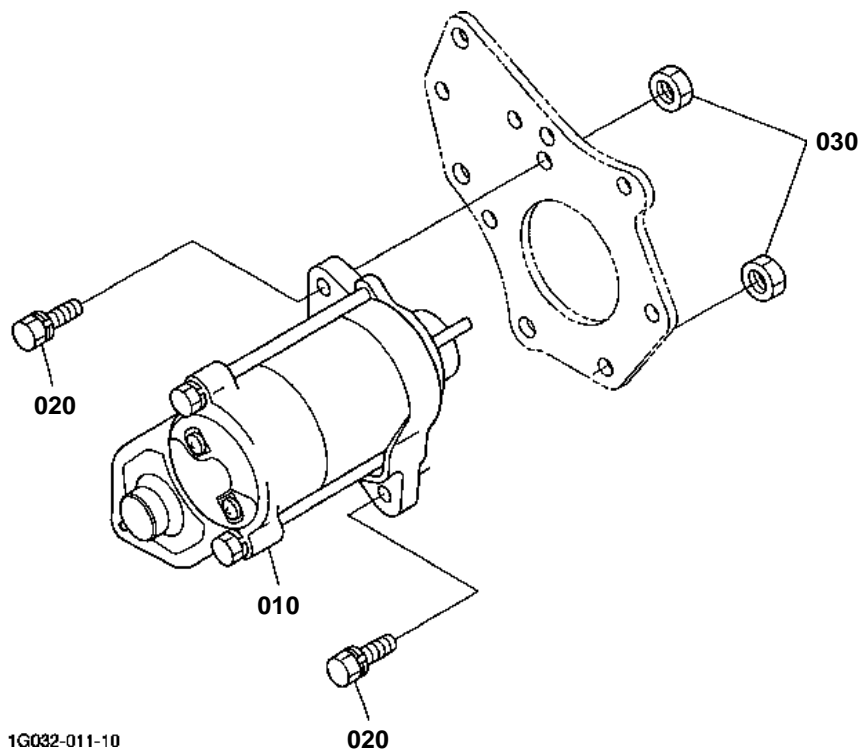



# STARTER

↔ Interchangeable; ≠ not interchangeable; ← new for old; → old for new

REF.No	Part No.	Description	Q'ty	S.No.	I/C	REMARKS	Weight (kgf)	Weight (lb)
010	17423-63010	ASSY STARTER	1				4	8.8
020	01123-50830	BOLT	2				0.015	0.033
030	02114-50080	NUT	2				0.005	0.011

# STARTER [COMPONENT PARTS]

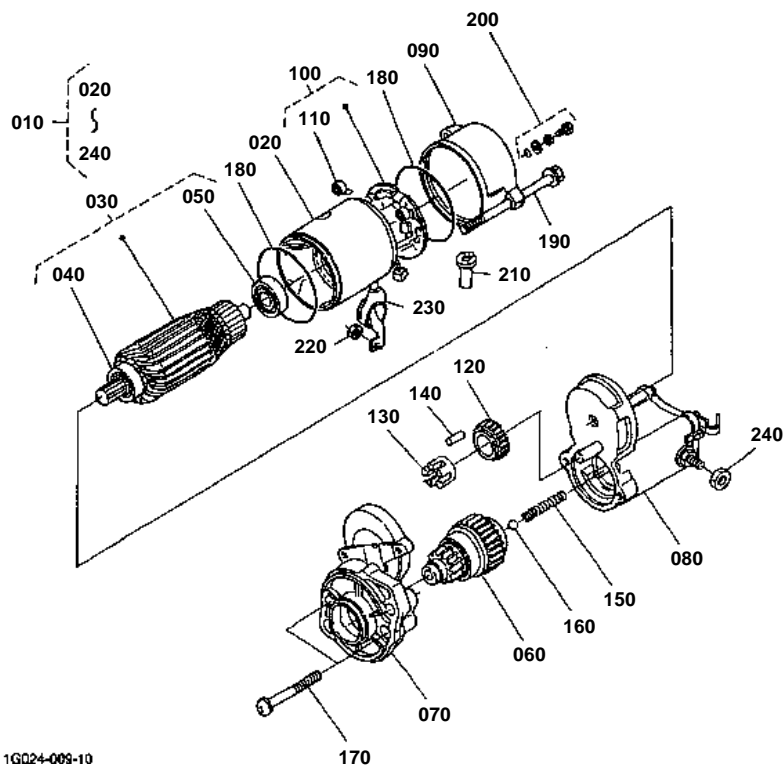



## STARTER [COMPONENT PARTS]

↔ Interchangeable; ≠ not interchangeable; ← new for old; → old for new

REF.No	Part No.	Description	Q'ty	S.No.	I/C	REMARKS	Weight (kgf)	Weight (lb)
010	17423-63010	ASSY STARTER	1				4	8.8
020	11197-63080	ASSY YOKE	1				0.92	2.024
030	11197-63070	ASSY ARMATURE	1				0.8	1.76
040	11460-63500	BEARING	1				0.03	0.066
050	11460-63530	BEARING	1				0.02	0.044
060	16235-63040	KIT STARTER	1				0.62	1.364
070	16235-63030	ASSY HOUSING STARTER	1				0.42	0.924
080	16285-63020	ASSY SWITCH MAGNETIC	1				0.95	2.09
090	17341-63200	FRAME END	1				0.13	0.286
100	11197-63380	ASSY HOLDER BRUSH	1				0.05	0.11
110	15401-63390	SPRING BRUSH	4				0.003	0.0066
120	11460-63270	GEAR	1				0.04	0.088
130	11460-63110	RETAINER	1				0.01	0.022
140	19212-63100	ROLLER	5				0.002	0.0044
150	11460-63120	SPRING	1				0.01	0.022
160	19212-97130	BALL	1				0.003	0.0066
170	11460-93310	BOLT	2				0.01	0.022
180	15511-96660	O RING	2				0.005	0.011
190	11197-63320	BOLT	2				0.02	0.044
200	15511-63760	ASSY BOLT	2				0.005	0.011
210	16285-63570	PIPE DRAIN	1				0.005	0.011
220	13963-92010	NUT HEXAGON	1				0.005	0.011
230	11173-63130	COVER TERMINAL	1				0.007	0.0154
240	16285-92010	NUT HEXAGON	1				0.005	0.011

OIL SWITCH/THERMOMETER AND PLUG

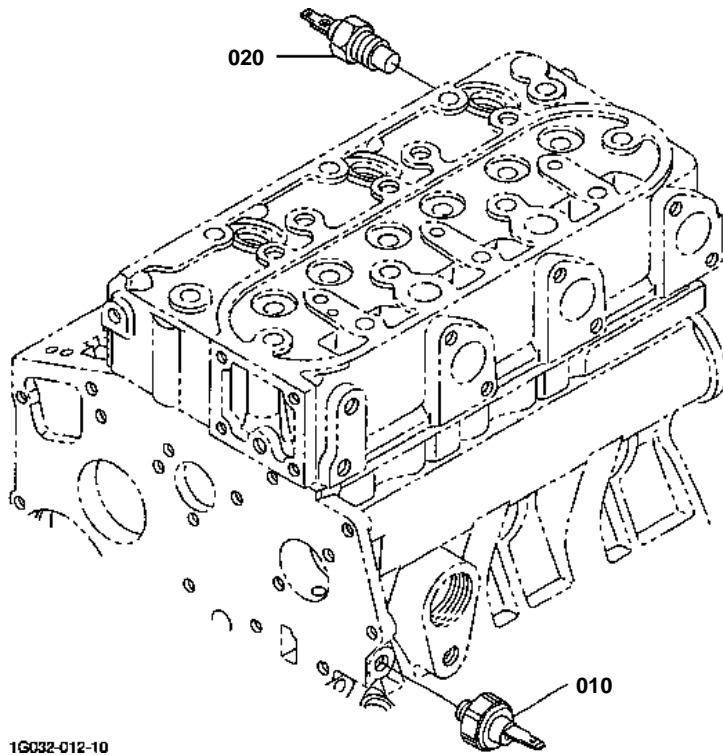



# OIL SWITCH/THERMOMETER AND PLUG

↔ Interchangeable; ≠ not interchangeable; ← new for old; → old for new

REF.No	Part No.	Description	Q'ty	S.No.	I/C	REMARKS	Weight (kgf)	Weight (lb)
010	15531-39010	SWITCH OIL	1				0.032	0.0704
020	31351-32830	SENSOR THERMO	1				0.02	0.044



WATER FLANGE AND THERMOSTAT

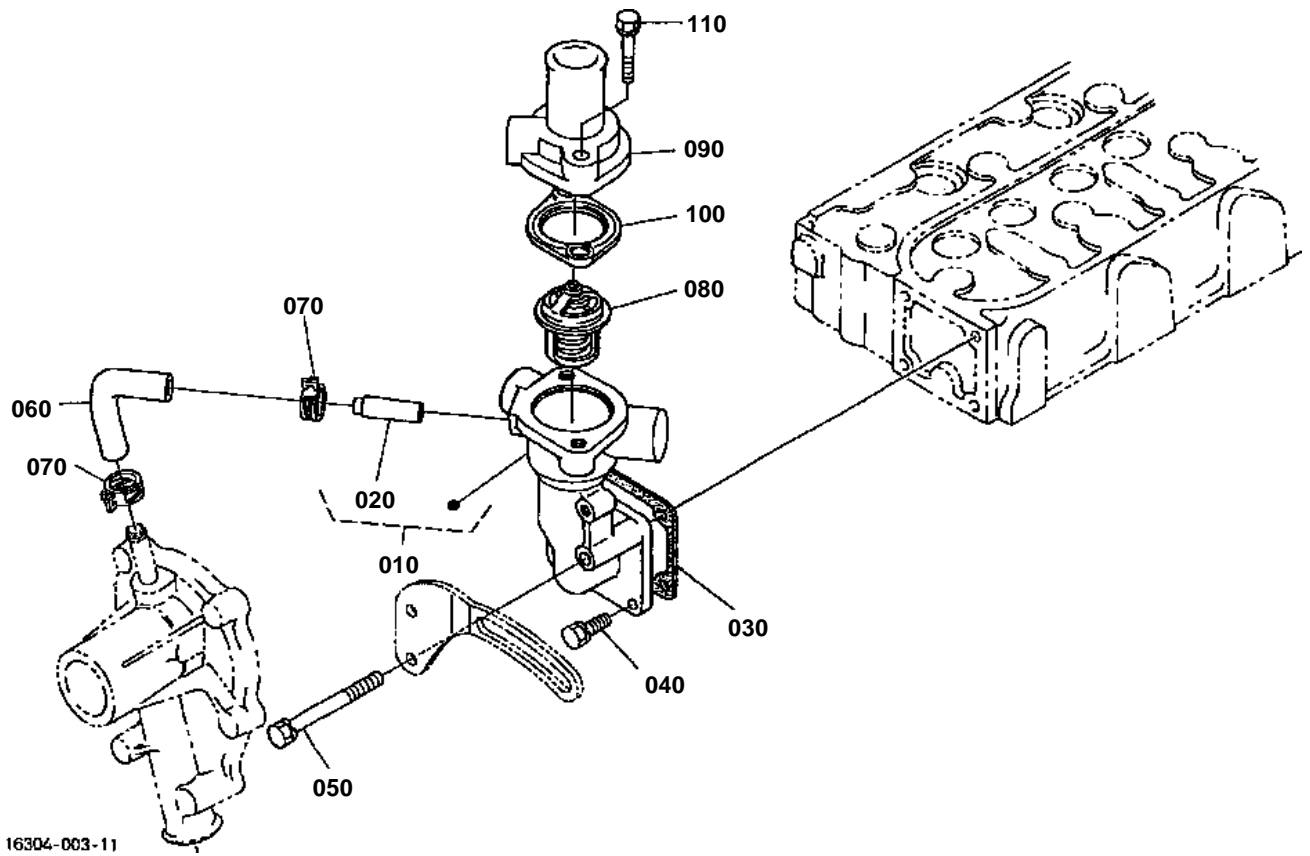



## WATER FLANGE AND THERMOSTAT

↔ Interchangeable; ≠ not interchangeable; ← new for old; → old for new

REF.No	Part No.	Description	Q'ty	S.No.	I/C	REMARKS	Weight (kgf)	Weight (lb)
010	16203-72700	COMP FLANGE WATER	1				0.25	0.55
020	16241-73370	PIPE WATER RETURN	1				0.007	0.0154
030	16264-72920	GASKET WATER FLANGE	1				0.001	0.0022
040	01023-50616	BOLT	3				0.005	0.011
050	01023-50655	BOLT	1				0.012	0.0264
060	16241-73350	PIPE WATER RETURN	1				0.015	0.033
070	16241-73360	BAND PIPE	2				0.003	0.0066
080	15321-73014	ASSY THERMOSTAT	1				0.07	0.154
090	16219-73260	COVER THERMOSTAT	1				0.094	0.2068
100	16221-73270	GASKET THERMOSTAT	1				0.013	0.0286
110	01123-50835	BOLT	2				0.02	0.044

WATER PUMP

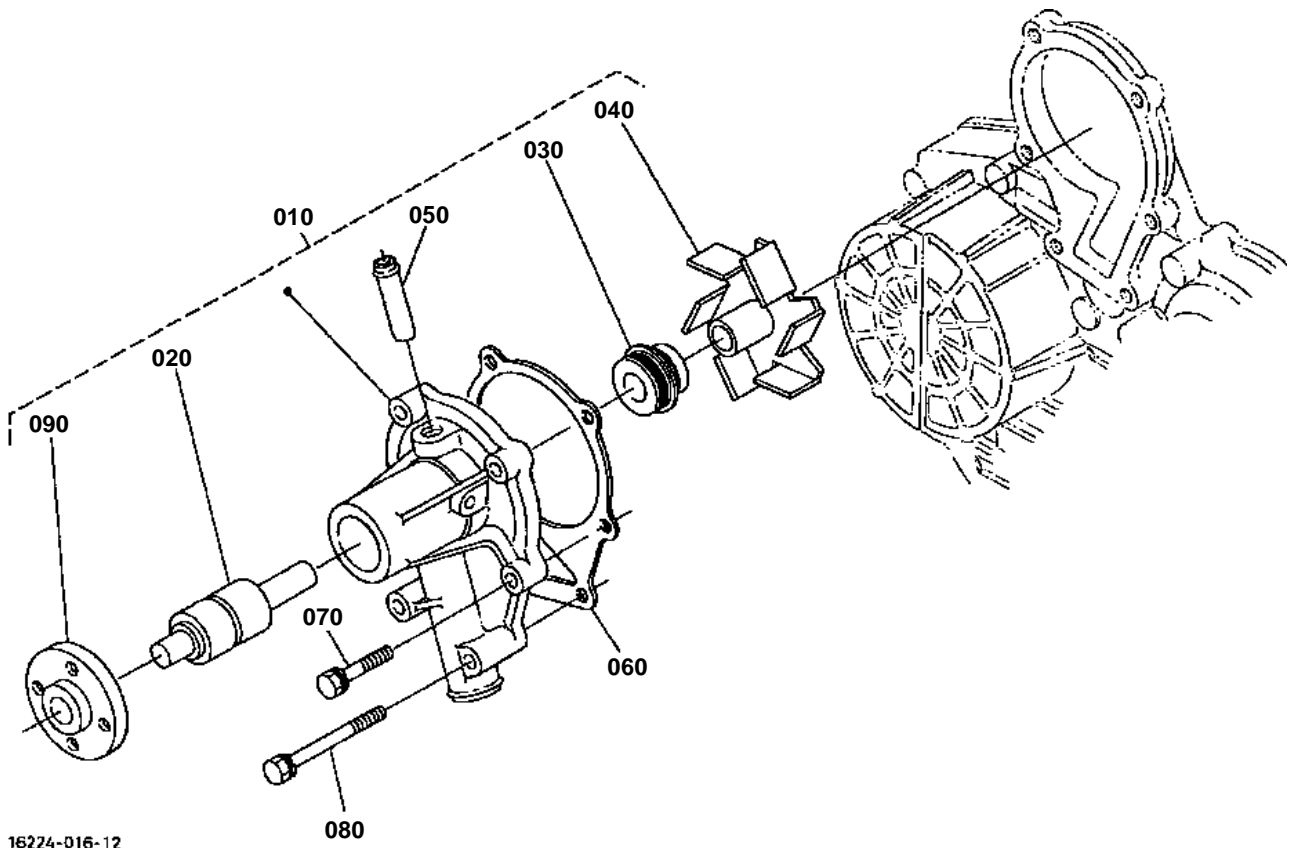



## WATER PUMP

↔ Interchangeable; ≠ not interchangeable; ← new for old; → old for new

REF.No	Part No.	Description	Q'ty	S.No.	I/C	REMARKS	Weight (kgf)	Weight (lb)
010	16251-73034	ASSY PUMP WATER	1				0.9	1.98
020	16259-73552	BEARING	1				0.21	0.462
030	1G642-73050	ASSY SEAL MECHANICAL	1				0.03	0.066
040	16259-73512	IMPELLER WATER PUMP	1				0.09	0.198
050	16241-73340	PIPE WATER RETURN	1				0.006	0.0132
060	16239-73430	GASKET WATER PUMP	1				0.007	0.0154
070	01023-50630	BOLT	4				0.008	0.0176
080	01023-50685	BOLT	2				0.018	0.0396
090	16259-73520	FLANGE WATER PUMP	1				0.15	0.33

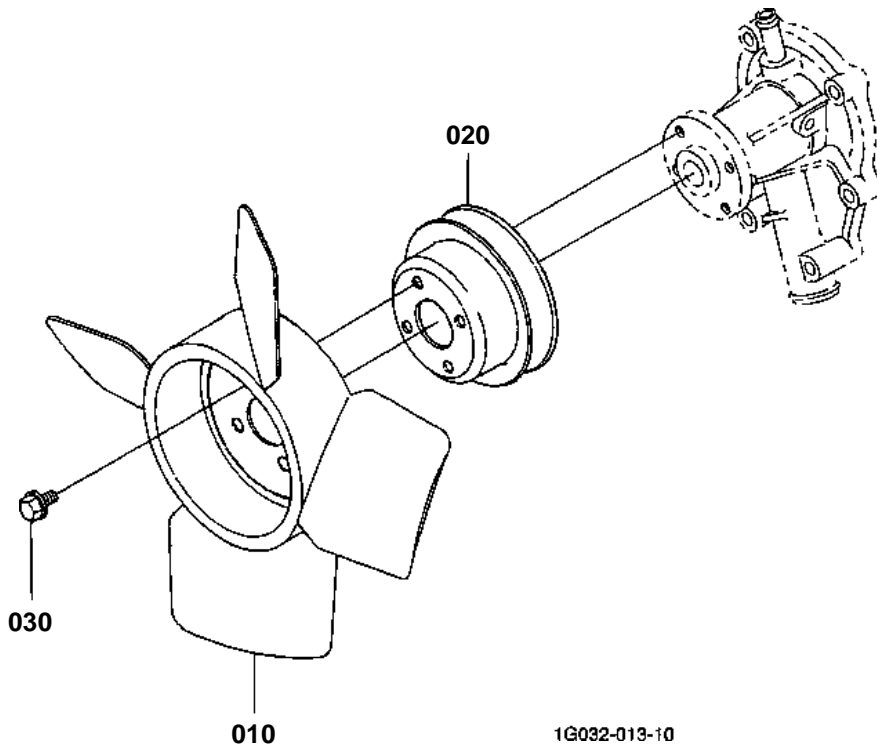



FAN

↔ Interchangeable; ≠ not interchangeable; ← new for old; → old for new

REF.No	Part No.	Description	Q'ty	S.No.	I/C	REMARKS	Weight (kgf)	Weight (lb)
010	15872-74110	FAN	1				0.25	0.55
020	16217-74250	PULLEY FAN	1				0.2	0.44
030	01754-50612	BOLT FLANGE	4				0.005	0.011

VALVE AND ROCKER ARM SOUPAPES

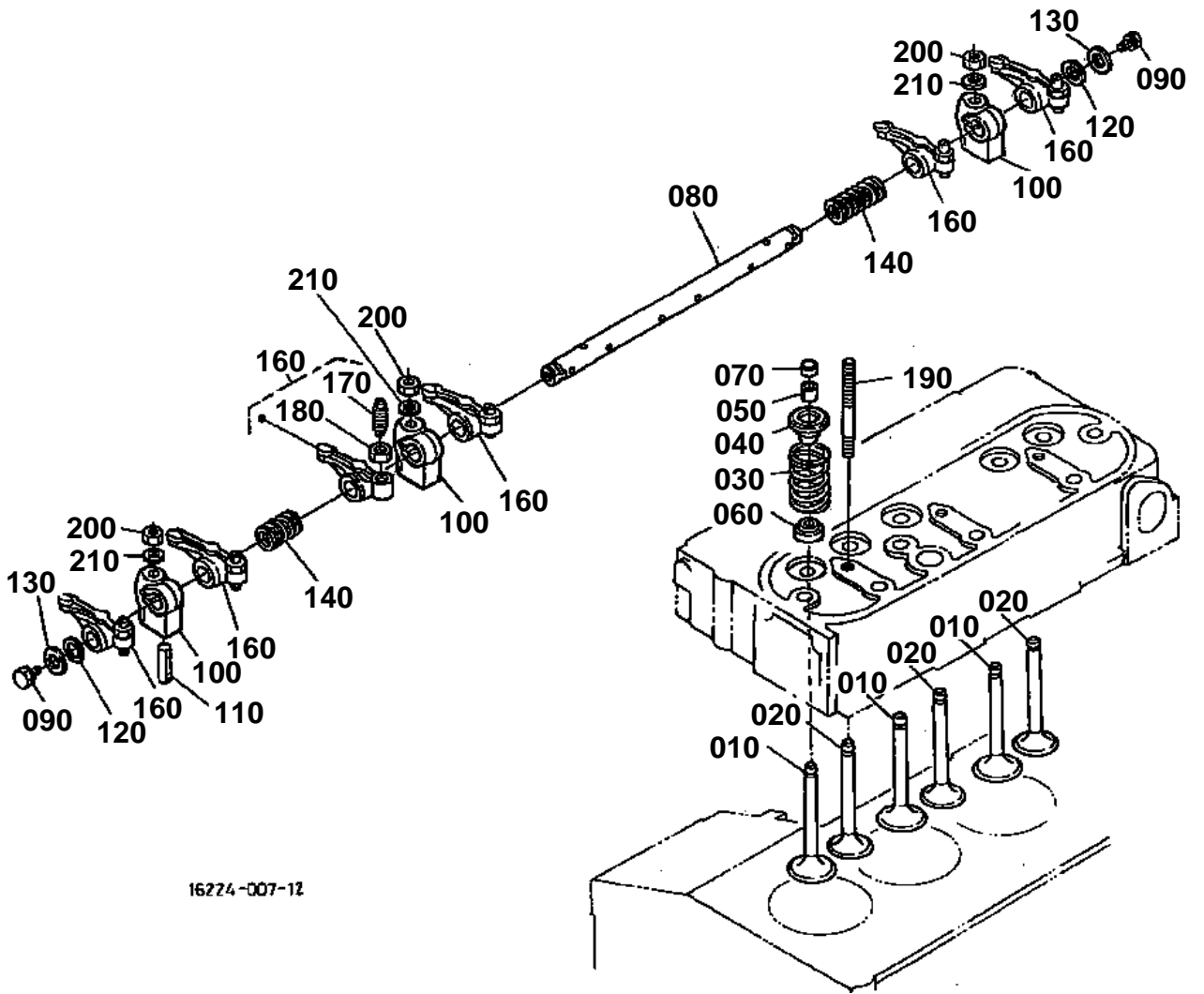

16224-007-12



## VALVE AND ROCKER ARM SOUPAPES

↔ Interchangeable; ≠ not interchangeable; ← new for old; → old for new

REF.No	Part No.	Description	Q'ty	S.No.	I/C	REMARKS	Weight (kgf)	Weight (lb)
010	16241-13110	VALVE INLET	3				0.05	0.11
020	16241-13120	VALVE EXHAUST	3				0.045	0.099
030	16271-13240	SPRING VALVE	6				0.015	0.033
040	16261-13330	RETAINER SPRING	6				0.016	0.0352
050	15261-13360	COLLET VALVE SPRING	6			SET	0.001	0.0022
060	1C010-13150	SEAL VALVE STEM	6				0.002	0.0044
070	16241-13280	CAP VALVE	6				0.005	0.011
080	16261-14264	SHAFT ROCKER ARM	1				0.16	0.352
090	01023-50610	BOLT	2				0.005	0.011
100	16241-14350	BRACKET ROCKER ARM	3				0.04	0.088
110	05411-00428	PIN SPRING	1				0.002	0.0044
120	16241-14430	WASHER R-ARM.SHAFT	2				0.002	0.0044
130	15841-94022	WASHER PLAIN	2				0.005	0.011
140	16241-14310	SPRING ROCKER ARM	2				0.004	0.0088
150	99999-99999	BLANK	0				0	0
160	16241-14032	ASSY ROCKER ARM	6				0.052	0.1144
170	16241-14230	SCREW ADJUSTING	6				0.008	0.0176
180	16241-14240	NUT	6				0.004	0.0088
190	16241-14410	STUD	3				0.022	0.0484
200	15261-92010	NUT	3				0.005	0.011
210	15261-94010	WASHER PLAIN	3				0.002	0.0044



INLET MANIFOLD

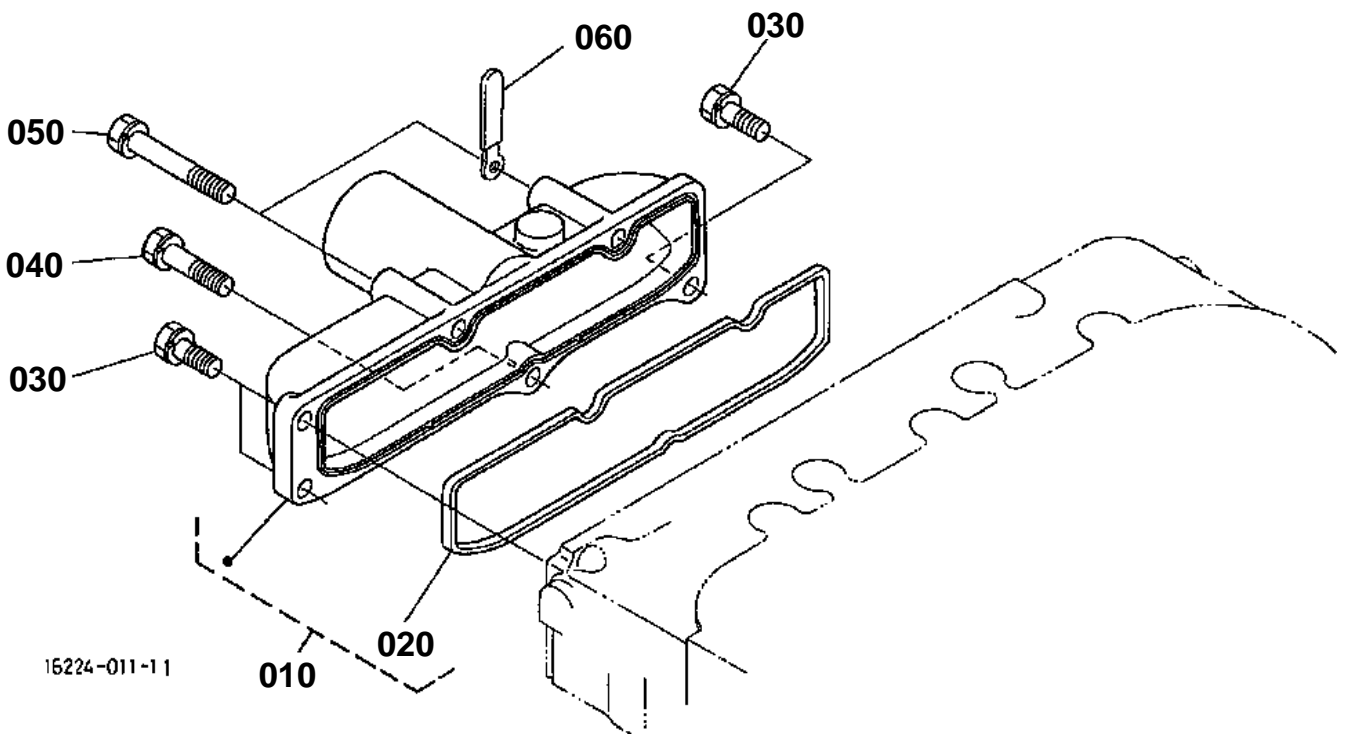



# INLET MANIFOLD

↔ Interchangeable; ≠ not interchangeable; ← new for old; → old for new

REF.No	Part No.	Description	Q'ty	S.No.	I/C	REMARKS	Weight (kgf)	Weight (lb)
010	16261-11770	ASSY MANIFOLD INLET	1				0.3	0.66
020	16261-11822	GASKET IN-MANIFOLD	1				0.01	0.022
030	01023-50618	BOLT	3				0.006	0.0132
040	01023-50630	BOLT	1				0.008	0.0176
050	01023-60650	BOLT	2				0.015	0.033
060	15272-67590	CLAMP CORD	1				0.004	0.0088

# EXHAUST MANIFOLD

---

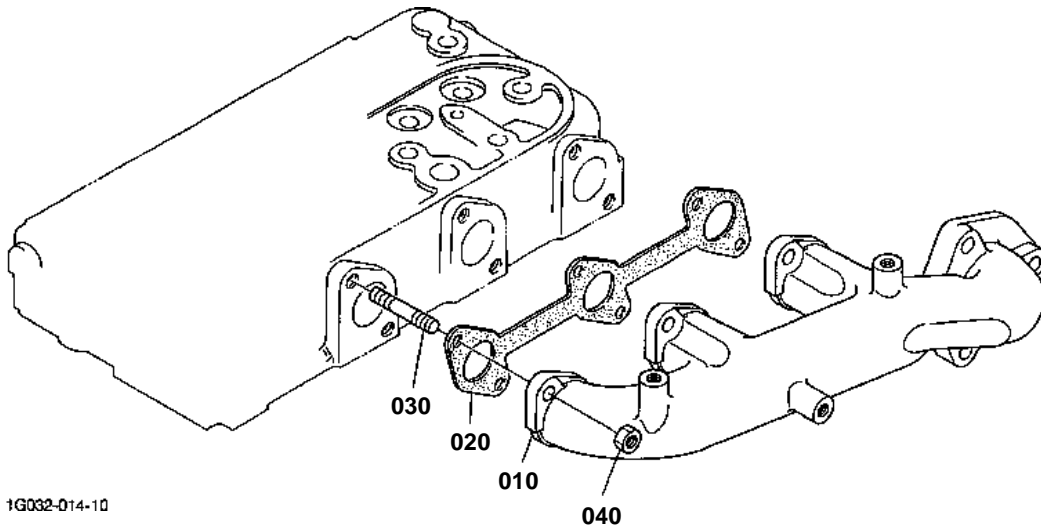

1G032-014-10



## EXHAUST MANIFOLD

↔ Interchangeable; ≠ not interchangeable; ← new for old; → old for new

REF.No	Part No.	Description	Q'ty	S.No.	I/C	REMARKS	Weight (kgf)	Weight (lb)
010	K2561-83210	MANIFOLD EXHAUST	1				1.95	4.29
020	16261-12350	GASKET EX-MANIFOLD	1				0.019	0.0418
030	16241-91490	STUD	6				0.005	0.011
040	16271-92010	NUT	6				0.005	0.011

# HYDRAULIC PUMP

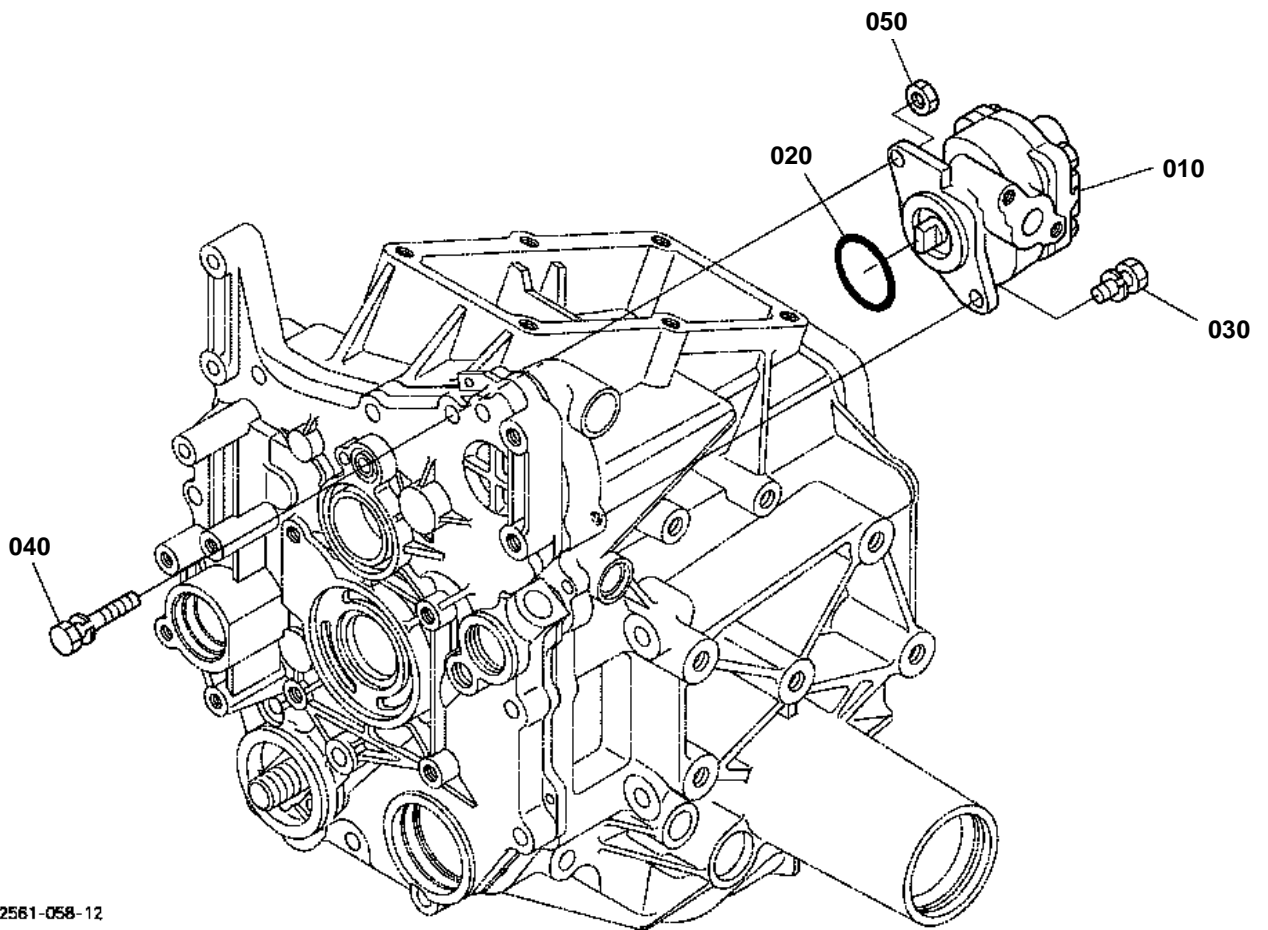

K2561-058-12



# HYDRAULIC PUMP

↔ Interchangeable; ≠ not interchangeable; ← new for old; → old for new

REF.No	Part No.	Description	Q'ty	S.No.	I/C	REMARKS	Weight (kgf)	Weight (lb)
010	6C040-36308	ASSY PUMP HYDRAULIC	1				1.28	2.816
020	04811-10460	O RING	1				0.002	0.0044
030	01123-50825	BOLT	1				0.013	0.0286
040	01123-50875	BOLT	1				0.04	0.088
050	02114-50080	NUT	1				0.005	0.011

HYDRAULIC PUMP [COMPONENT PARTS]

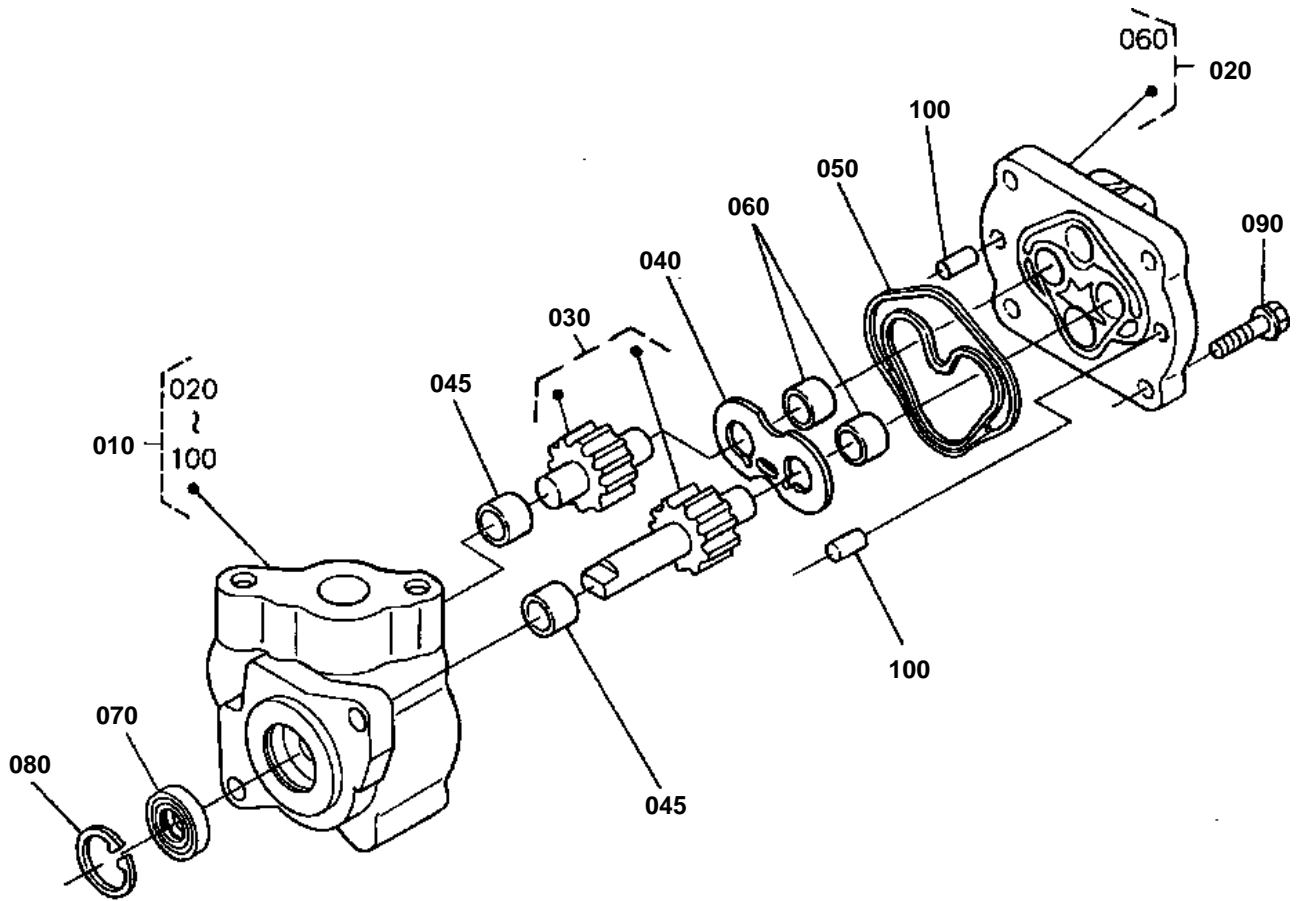

16216-002-13



## HYDRAULIC PUMP [COMPONENT PARTS]

↔ Interchangeable; ≠ not interchangeable; ← new for old; → old for new

REF.No	Part No.	Description	Q'ty	S.No.	I/C	REMARKS	Weight (kgf)	Weight (lb)
010	6C040-36308	ASSY PUMP HYDRAULIC	1				1.28	2.816
020	6A100-37502	COMP.COVER	1				0.26	0.572
030	6C040-36392	COMP.GEAR HYD.PUMP	1				0.309	0.6798
040	6C140-36350	PLATE SIDE	1				0.05	0.11
045	6A100-37232	BUSH	2				0.005	0.011
050	6C040-36344	RING DOUBLE	1				0.003	0.0066
060	6A100-37232	BUSH	2				0.005	0.011
070	31381-76390	SEAL OIL	1				0.01	0.022
080	04611-00300	CIR CLIP INTERNAL	1				0.004	0.0088
090	01754-51030	BOLT FLANGE	4				0.03	0.066
100	05012-00814	PIN STRAIGHT	2				0.006	0.0132



UPPER GASKET KIT

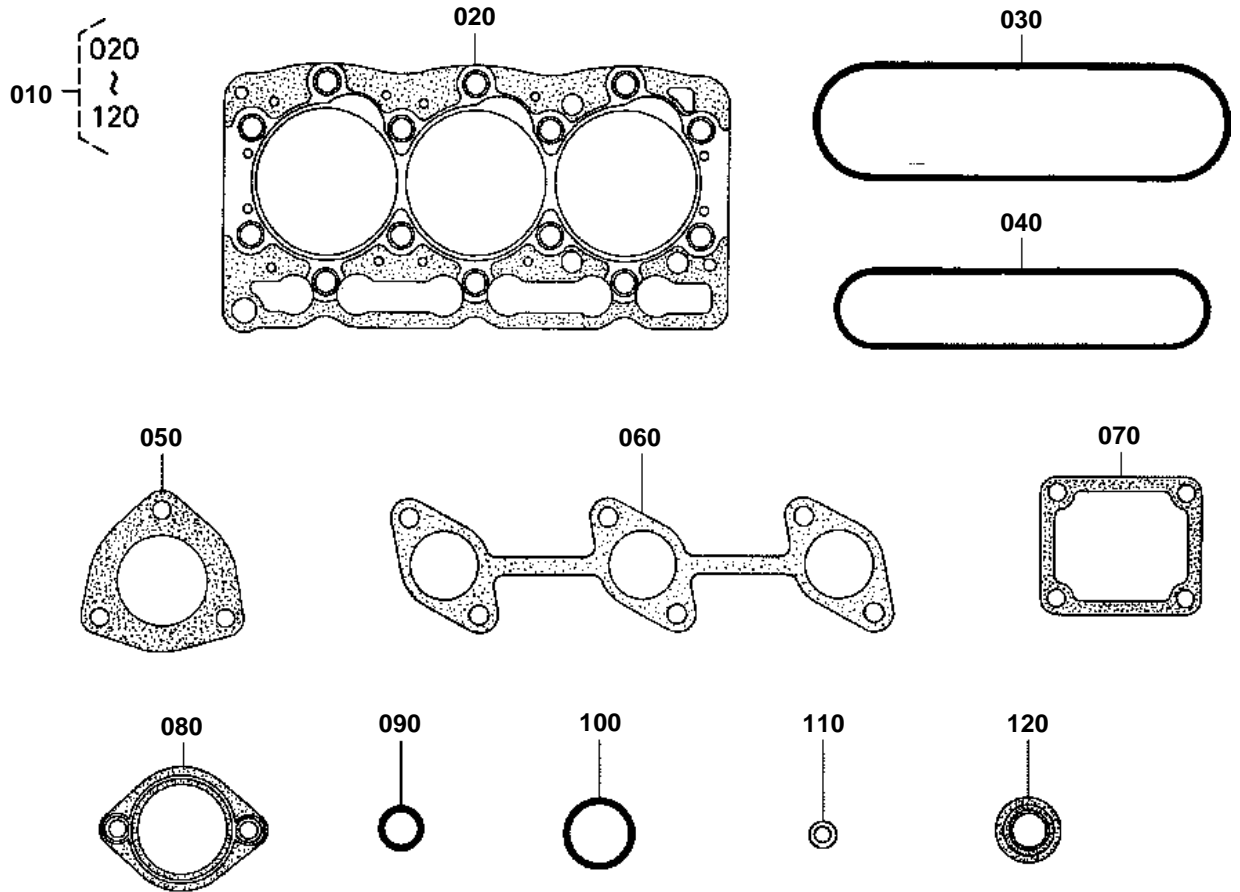

1G032-019-11



## UPPER GASKET KIT

↔ Interchangeable; ≠ not interchangeable; ← new for old; → old for new

REF.No	Part No.	Description	Q'ty	S.No.	I/C	REMARKS	Weight (kgf)	Weight (lb)
010	1G032-99350	KIT GASKET UPPER	1				0.2	0.44
020	16221-03310	GASKET CYLINDER HEAD	1				0.075	0.165
030	16261-14520	GASKET HEAD COVER	1				0.01	0.022
040	16261-11822	GASKET IN-MANIFOLD	1				0.01	0.022
050	15862-12230	GASKET MUFFLER NA	1				0.015	0.033
060	16261-12350	GASKET EX-MANIFOLD	1				0.019	0.0418
070	16264-72920	GASKET WATER FLANGE	1				0.001	0.0022
080	16221-73270	GASKET THERMOSTAT	1				0.013	0.0286
090	15221-33700	O RING	1				0.001	0.0022
100	04814-50300	O RING	1				0.001	0.0022
110	15951-96660	GASKET	3				0.001	0.0022
120	1C010-13150	SEAL VALVE STEM	6				0.002	0.0044

LOWER GASKET KIT

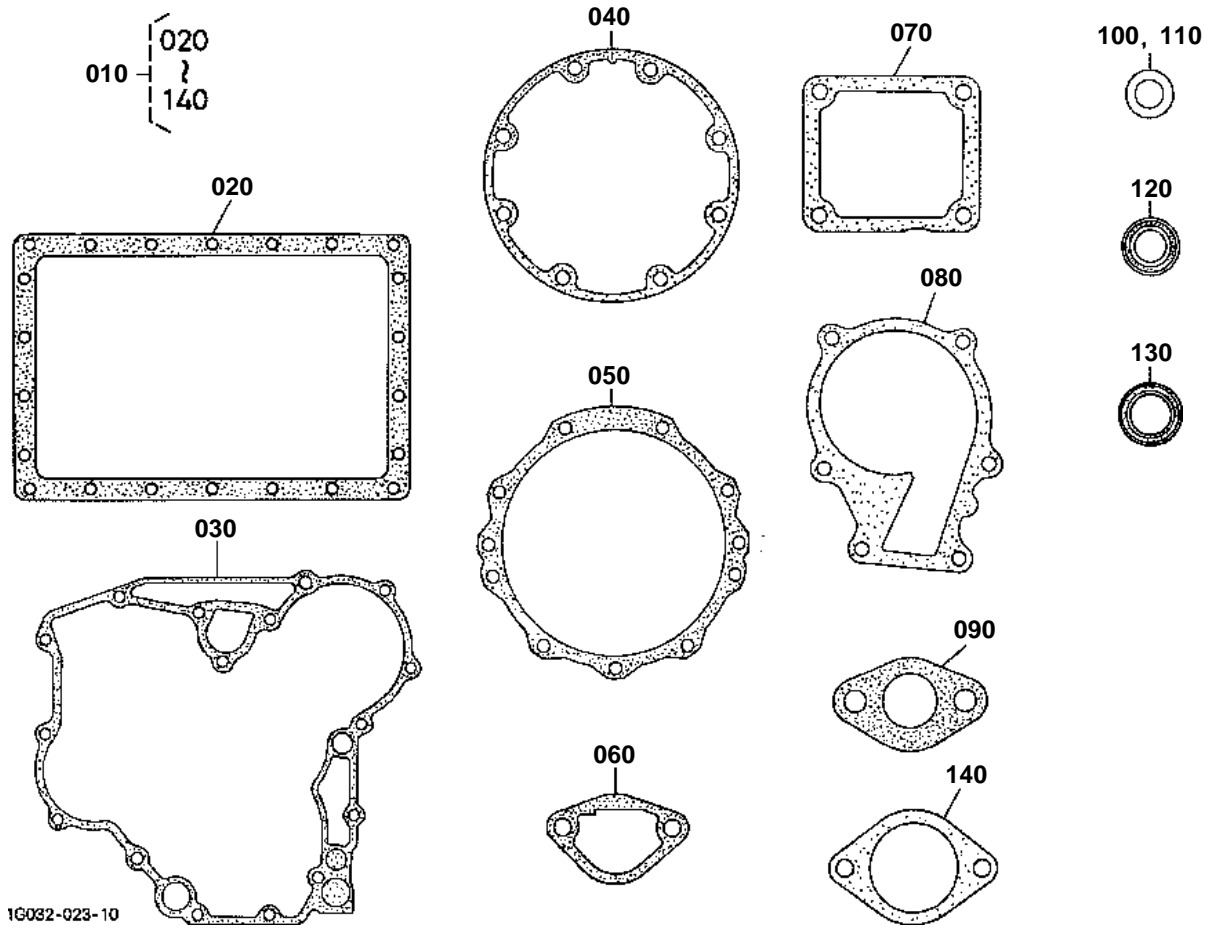



## LOWER GASKET KIT

↔ Interchangeable; ≠ not interchangeable; ← new for old; → old for new

REF.No	Part No.	Description	Q'ty	S.No.	I/C	REMARKS	Weight (kgf)	Weight (lb)
010	1G032-99360	KIT GASKET LOWER	1				0.2	0.44
020	16266-01620	GASKET OIL PAN	1				0.028	0.0616
030	16264-04130	GASKET GEAR CASE	1				0.01	0.022
040	16264-04360	GASKET BRG.CASE	1				0.002	0.0044
050	16264-04820	GASKET	1				0.008	0.0176
060	16264-52140	GASKET FUEL PUMP	1				0.001	0.0022
070	16264-57210	GASKET	1				0.002	0.0044
080	16239-73430	GASKET WATER PUMP	1				0.007	0.0154
090	16299-56260	GASKET	1				0.002	0.0044
100	15601-96650	GASKET	6				0.001	0.0022
110	15841-53622	GASKET	3				0.002	0.0044
120	16241-04212	SEAL OIL	1				0.012	0.0264
130	16241-04460	SEAL OIL	1				0.02	0.044
140	16299-83110	GASKET PUMP COVER NA	1				0.005	0.011

AIR CLEANER

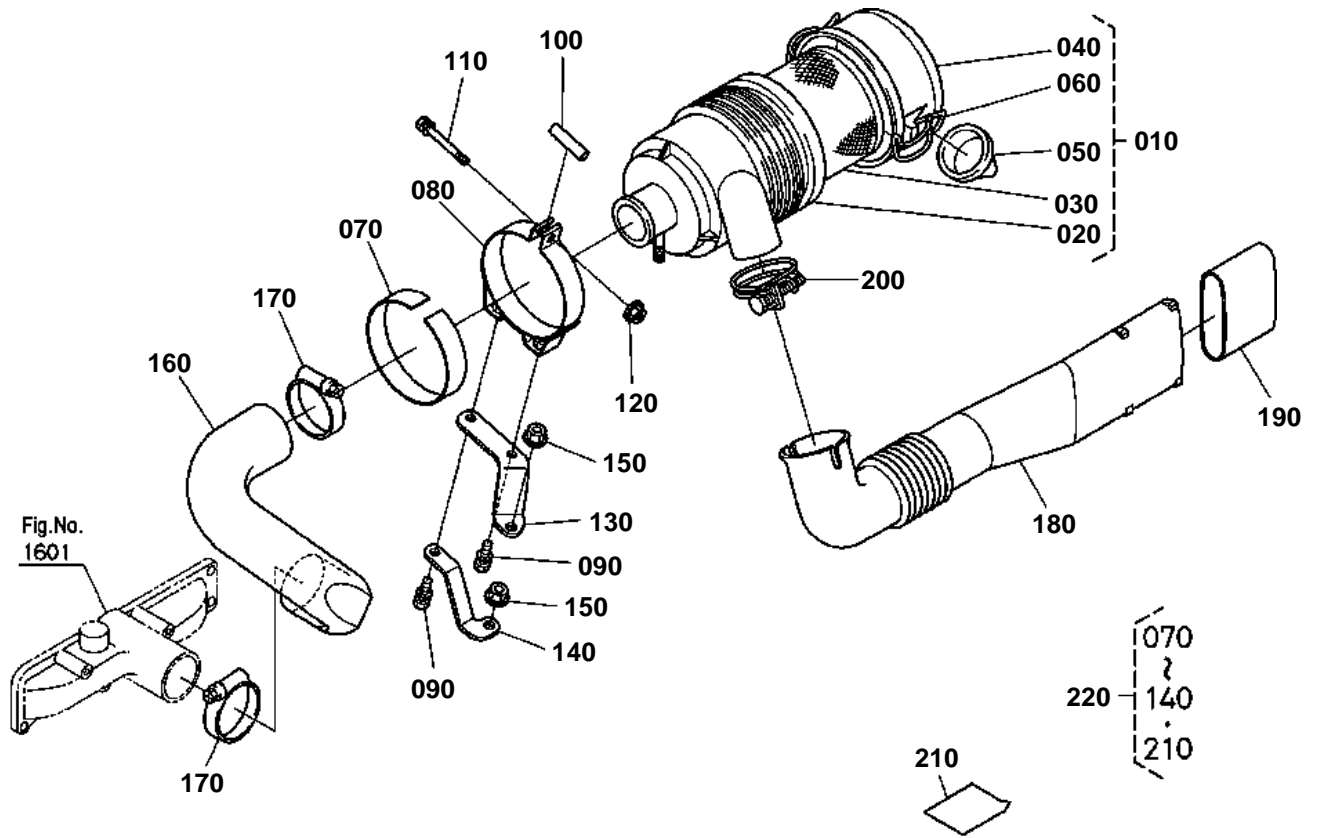

K2591-052-10

**AIR CLEANER**

↔ Interchangeable; ≠ not interchangeable; ← new for old; → old for new

REF.No	Part No.	Description	Q'ty	S.No.	I/C	REMARKS	Weight (kgf)	Weight (lb)
010	K1211-82110	AIR CLEANER ASSY	1				0.57	1.254
020	K1211-82310	BODY	1				0.23	0.506
030	K1211-82320	ELEMENT	1				0.26	0.572
040	K1211-82330	ASSY COVER	1				0.12	0.264
050	K1211-82340	DUST EJECTOR VALVE	1				0.018	0.0396
060	K1211-82350	CLIP	2				0.01	0.022
070	15371-11870	CUSHION	1				0.025	0.055
080	15371-11252	BAND AIR CLEANER	1				0.21	0.462
090	01123-50820	BOLT	2				0.011	0.0242
100	PA505-73160	COLLAR	1				0.015	0.033
110	01123-50870	BOLT	1				0.029	0.0638
120	02751-50080	NUT FLANGE	1				0.006	0.0132
130	K2561-82180	STAY AIR CLEANER	1				0	0
140	K2561-82190	STAY AIR CLEANER	1				0	0
150	02771-60100	NUT FLANGE	2				0.01	0.022
160	K2561-82120	HOSE INLET	1				0.2	0.44
170	K1211-82170	BAND PIPE	2				0.03	0.066
180	K2561-82130	PIPE INTAKE	1				0.185	0.407
190	K2561-82160	CUSHION INTAKE PIPE	1				0.014	0.0308
200	09318-89052	CLAMP HOSE	1				0.03	0.066
210	99999-99999	MANUAL ASSEMBLY	1				0	0
220	K2561-98210	KIT BRACKET(AIR CLEA	1				0.9	1.98

MUFFLER

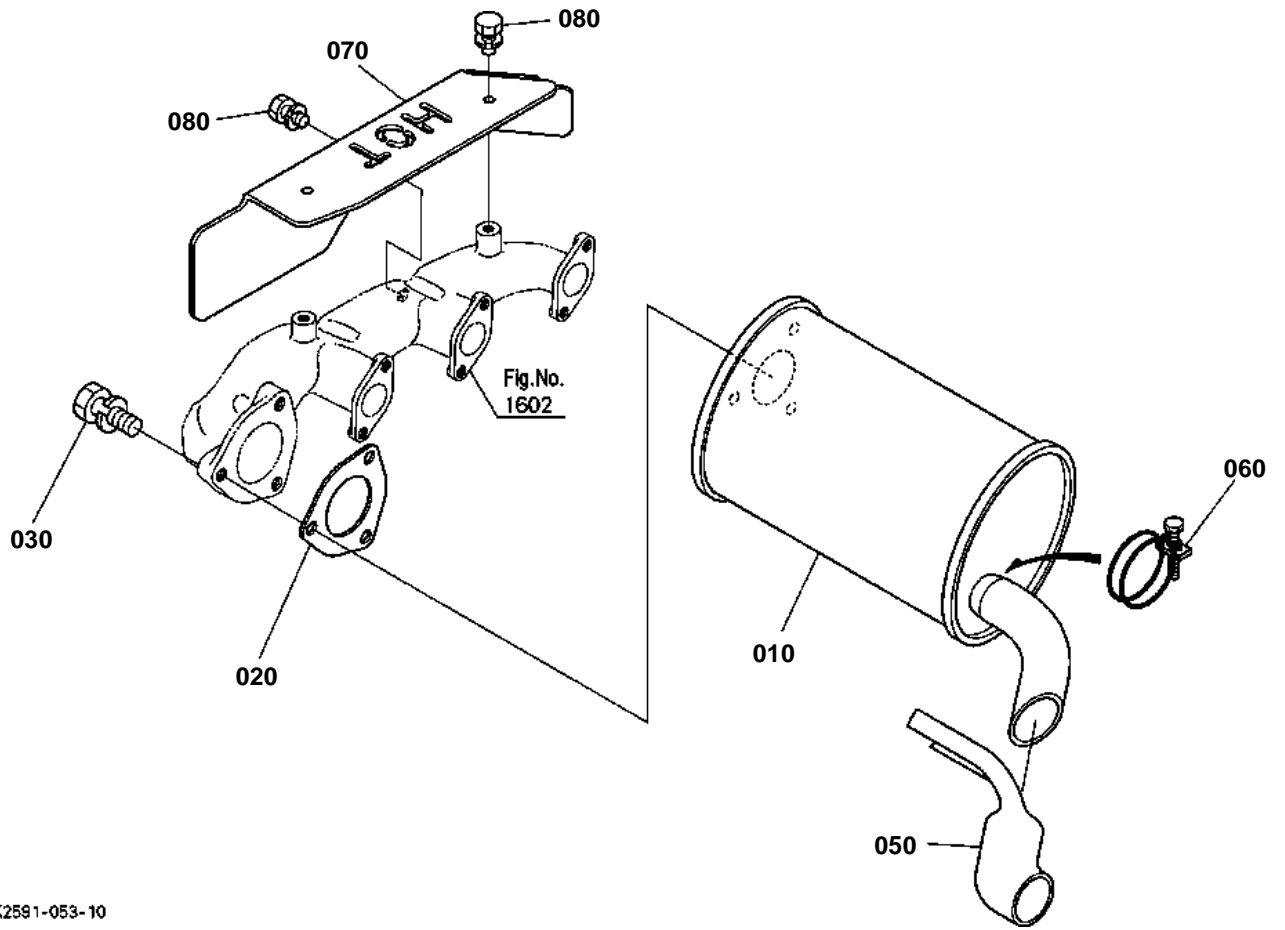

K2591-053-10



# MUFFLER

↔ Interchangeable; ≠ not interchangeable; ← new for old; → old for new

REF.No	Part No.	Description	Q'ty	S.No.	I/C	REMARKS	Weight (kgf)	Weight (lb)
010	K2561-83110	COMP.MUFFLER	1				2.22	4.884
020	15862-12230	GASKET MUFFLER NA	1				0.015	0.033
030	01123-50830	BOLT	3				0.015	0.033
040	99999-99999	BLANK	0				0	0
050	K2591-83120	PIPE EXHAUST	1				0.08	0.176
060	67980-58640	CLAMP HOSE	1				0.02	0.044
070	K2561-83224	COVER HEAT PROOF	1				0.49	1.078
080	01023-50610	BOLT	3				0.005	0.011



HYDRAULIC PUMP COVER

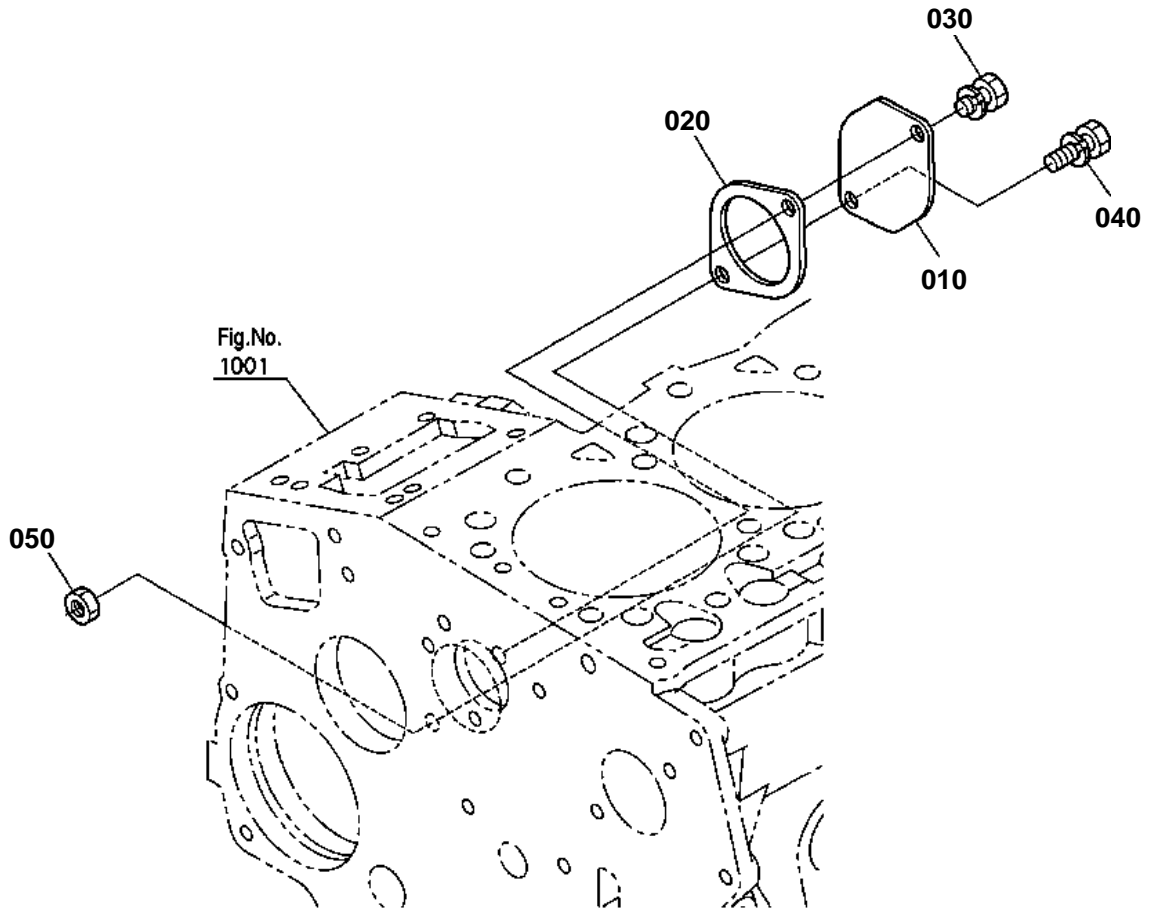

K2591-055-10



## HYDRAULIC PUMP COVER

↔ Interchangeable; ≠ not interchangeable; ← new for old; → old for new

REF.No	Part No.	Description	Q'ty	S.No.	I/C	REMARKS	Weight (kgf)	Weight (lb)
010	K2561-84110	PLATE PUMP HOLE	1				0.102	0.2244
020	16299-83110	GASKET PUMP COVER NA	1				0.005	0.011
030	01123-50820	BOLT	1				0.011	0.0242
040	01123-50830	BOLT	1				0.015	0.033
050	02114-50080	NUT	1				0.005	0.011

ACCELERATOR LEVER

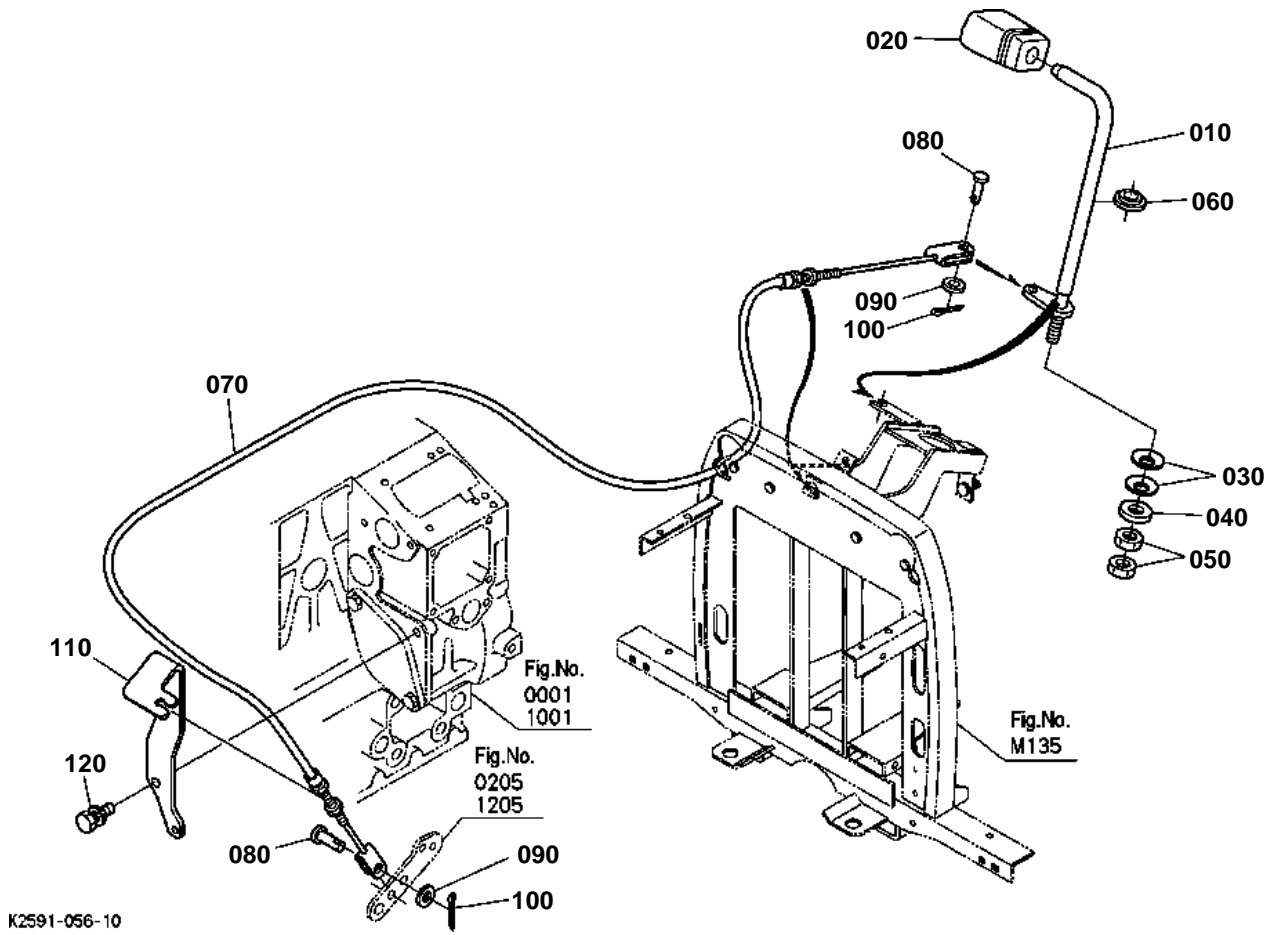

## OLD PARTS

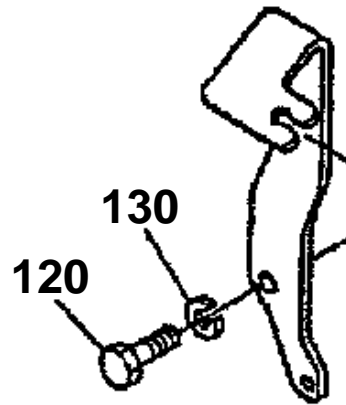

K2591-801-11



## ACCELERATOR LEVER

↔ Interchangeable; ≠ not interchangeable; ← new for old; → old for new

REF.No	Part No.	Description	Q'ty	S.No.	I/C	REMARKS	Weight (kgf)	Weight (lb)
010	K2561-45120	LEVER ACCEL.	1				0.198	0.4356
020	K2561-45210	GRIP	1				0.031	0.0682
030	66116-51530	SPRING PLATE	2				0.003	0.0066
040	75599-32112	WASHER PLAIN	1				0.001	0.0022
040	04015-60080	WASHER PLAIN	1		↔		0.01	0.022
050	02114-50080	NUT	2				0.005	0.011
060	K2561-45160	COVER ACCEL.LEVER	1				0.01	0.022
070	K2561-45150	WIRE ENGINE	1				0.16	0.352
080	75599-51112	PIN CLEVIS	2				0.005	0.011
090	75599-32011	WASHER PLAIN	2				0.001	0.0022
090	04013-60060	WASHER PLAIN	2		↔		0.001	0.0022
100	75599-53152	PIN COTTER	2				0.001	0.0022
110	K2561-81510	BRACKET WIRE	1				0.001	0.0022
120	01133-51020	BOLT	1				0.02	0.044

FUEL TANK

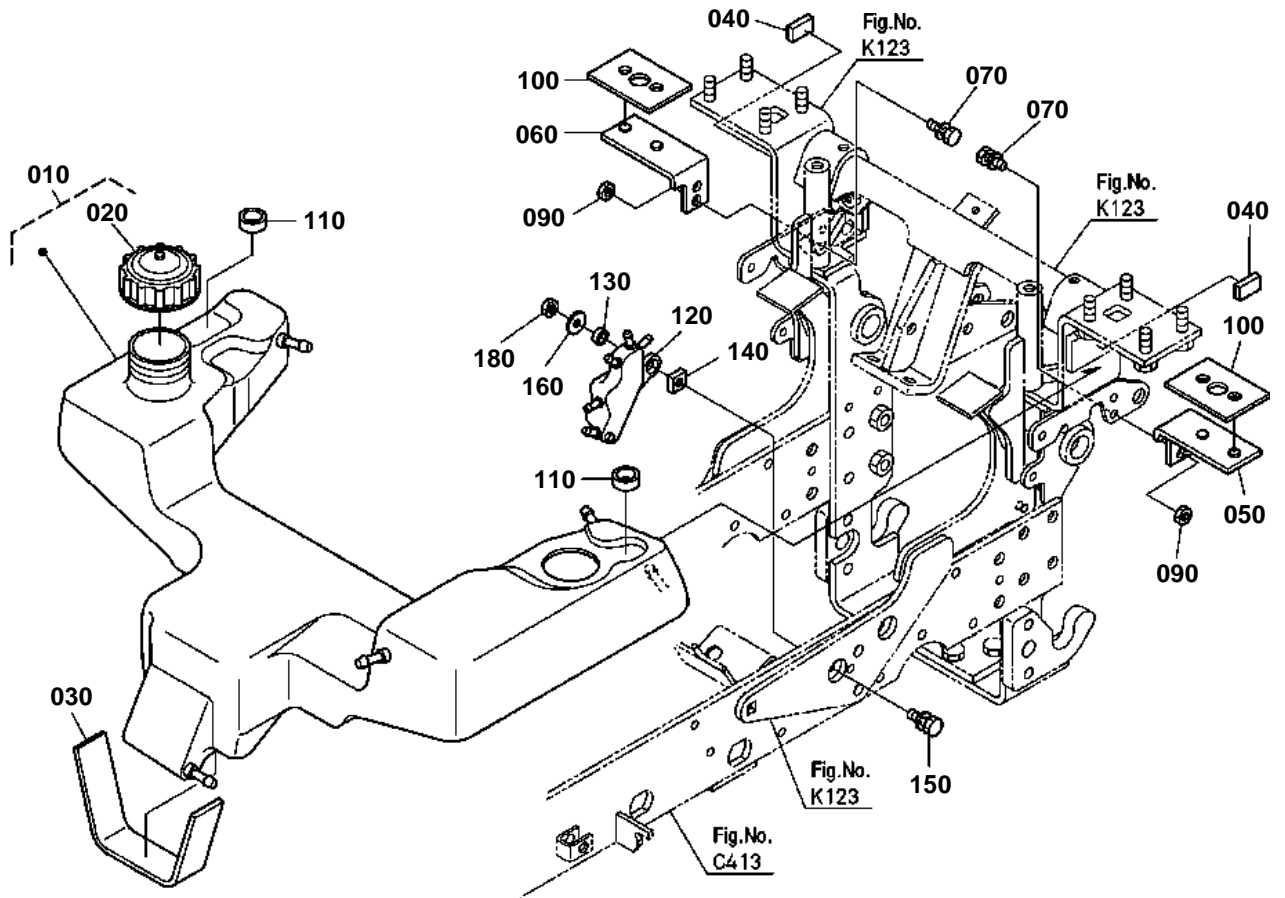

K2591-002-12

# OLD PARTS

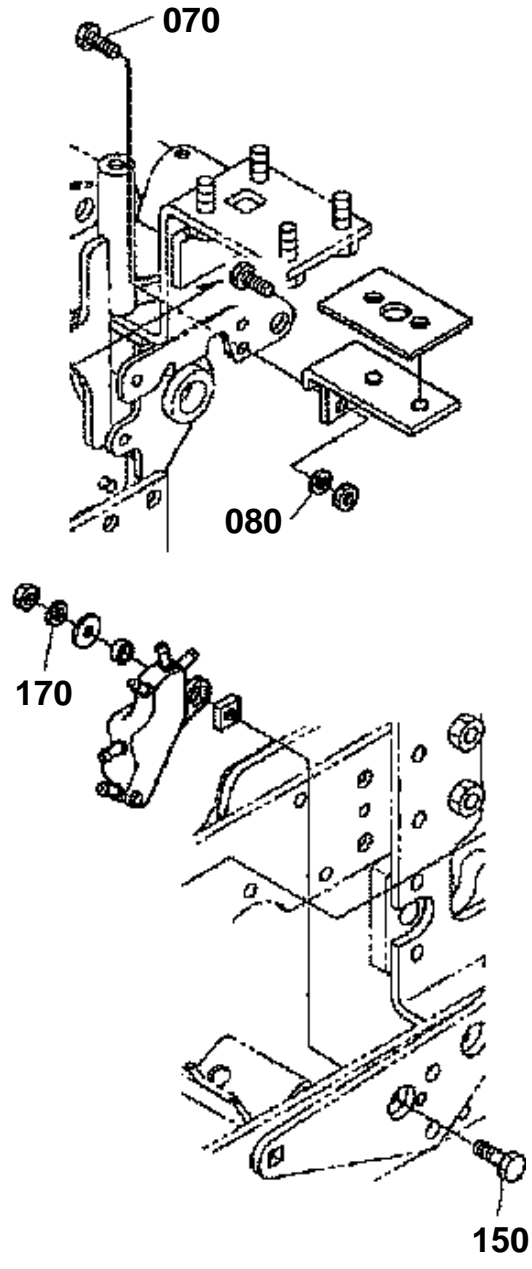

K2591-820-11

**FUEL TANK**

↔ Interchangeable; ≠ not interchangeable; ← new for old; → old for new

REF.No	Part No.	Description	Q'ty	S.No.	I/C	REMARKS	Weight (kgf)	Weight (lb)
010	K2561-54700	ASSY TANK FUEL	1				6.5	14.3
020	K1211-24120	CAP FUEL	1				0.1	0.22
030	K2561-54780	CUSHION TANK FRONT	1				0.029	0.0638
040	K2561-54850	CUSHION TANK	2				0.002	0.0044
050	K2561-54810	STAY FUEL TANK LH	1				0	0
060	K2561-54820	STAY FUEL TANK RH	1				0	0
070	01133-51030	BOLT	4				0.025	0.055
090	02018-50100	NUT	4				0.011	0.0242
090	02118-50100	NUT	4		↔		0.005	0.011
100	K2561-54830	CUSHION TANK REAR LO	2				0.08	0.176
110	K2561-54840	CUSHION TANK REAR UP	2				0.018	0.0396
120	K2561-54910	TANK FUEL	1				0.05	0.11
130	K2561-54920	COLLAR TANK	1				0.011	0.0242
140	K2561-54930	PLATE TANK	1				0.035	0.077
150	01133-51045	BOLT	1				0.034	0.0748
160	04015-50100	WASHER PLAIN	1				0.016	0.0352
180	02018-50100	NUT	1				0.011	0.0242
180	02118-50100	NUT	1		↔		0.005	0.011



FUEL PIPE

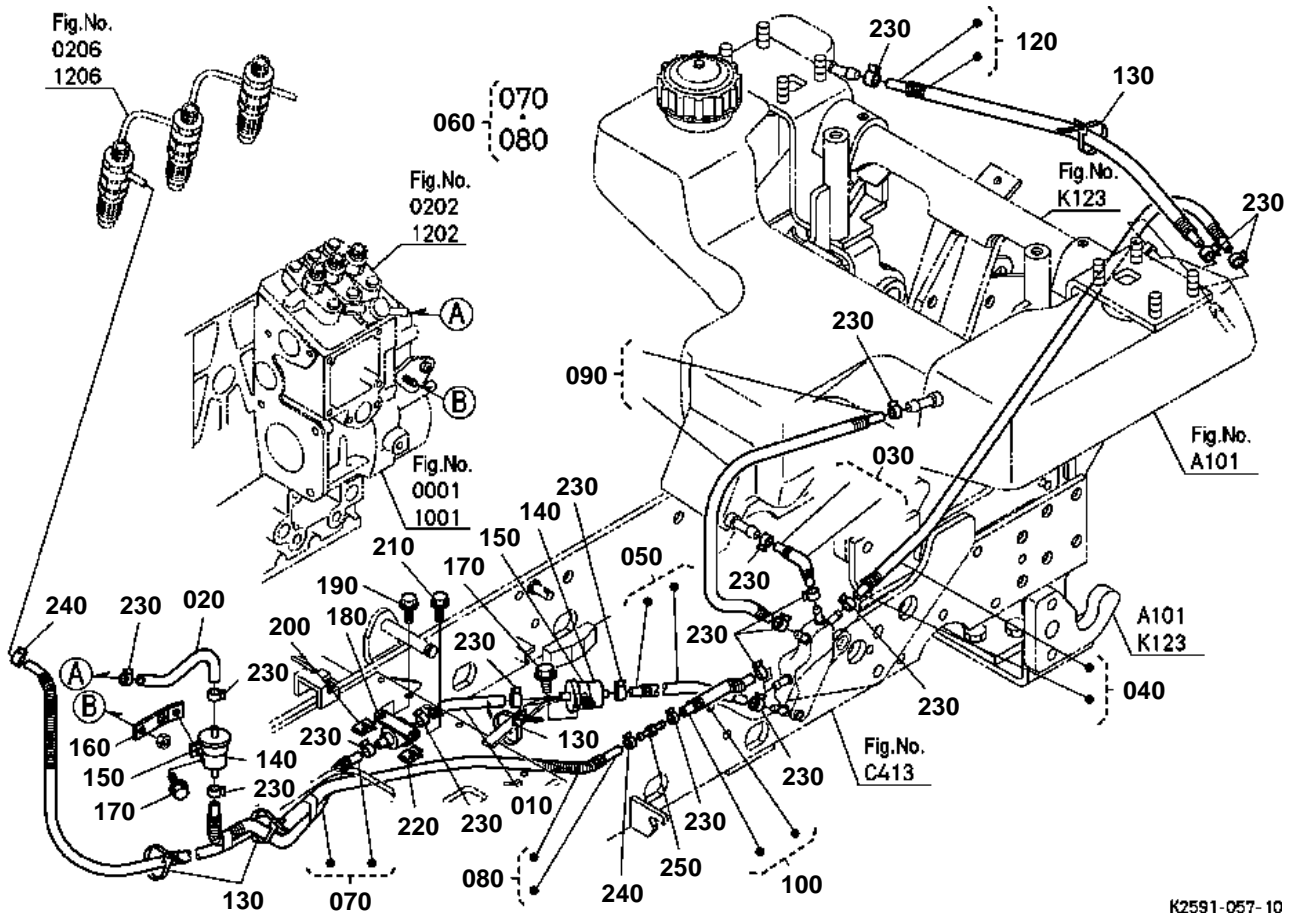

K2591-057-10



FUEL PIPE

↔ Interchangeable; ≠ not interchangeable; ← new for old; → old for new

REF.No	Part No.	Description	Q'ty	S.No.	I/C	REMARKS	Weight (kgf)	Weight (lb)
010	K2561-24420	TUBE FUEL	1				0.015	0.033
020	99999-99999	BLANK	0				0	0
030	K2561-24110	ASSY TUBE FUEL TF	1				0.047	0.1034
040	K2561-24100	ASSY TUBE FUEL TR	1				0.14	0.308
050	K2561-24040	ASSY TUBE FUEL	1				0.063	0.1386
060	K2561-24010	ASSY TUBE FUEL R	1				0.17	0.374
070	K2561-24050	ASSY TUBE FUEL	1				0.155	0.341
080	K2561-24080	ASSY TUBE FUEL RE.	1				0.165	0.363
090	K2561-24090	ASSY TUBE FUEL RE.	1				0.1	0.22
100	K2561-24070	ASSY TUBE FUEL RE.	1				0.04	0.088
110	99999-99999	BLANK	0				0	0
120	K2561-24060	ASSY TUBE FUEL BR.	1				0.01	0.022
130	K1122-61230	CLAMP CORD	3				0.001	0.0022
140	12581-43012	ASSY FILTER FUEL	2				0.035	0.077
150	66103-58330	BAND FILTER	2				0.01	0.022
160	K2561-24510	STAY FUEL FILTER	1				0.026	0.0572
170	01754-50616	BOLT FLANGE	2				0.006	0.0132
170	01754-50620	BOLT FLANGE	2		↔		0.007	0.0154
180	RC601-51350	ASSY PUMP FUEL	1				0.31	0.682
190	01754-50625	BOLT FLANGE	1				0.008	0.0176
200	K1122-91800	NUT(M)	1				0.004	0.0088
210	01754-50825	BOLT FLANGE	1				0.01	0.022
220	K1122-91810	NUT(M)	1				0.01	0.022
230	09318-88125	CLAMP HOSE	18				0.001	0.0022
240	09318-88095	CLAMP HOSE	2				0.002	0.0044
250	K2561-24550	JOINT PIPE FUEL	1				0.008	0.0176

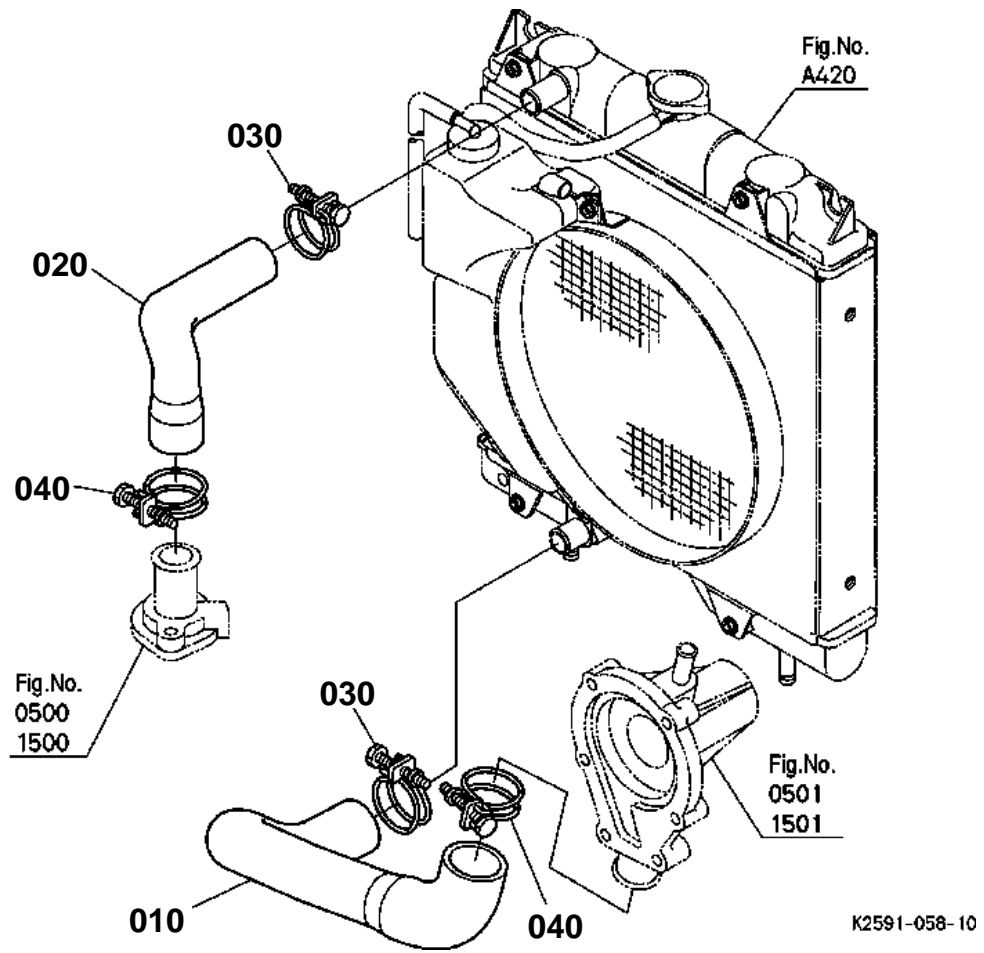



## WATER PIPE

↔ Interchangeable; ≠ not interchangeable; ← new for old; → old for new

REF.No	Part No.	Description	Q'ty	S.No.	I/C	REMARKS	Weight (kgf)	Weight (lb)
010	K2561-85150	HOSE WATER LOWER	1				0.168	0.3696
020	K2561-85160	HOSE WATER UPPER	1				0.12	0.264
030	09318-89036	CLAMP HOSE	2				0.025	0.055
040	09318-89039	CLAMP HOSE	2				0.02	0.044

RADIATOR

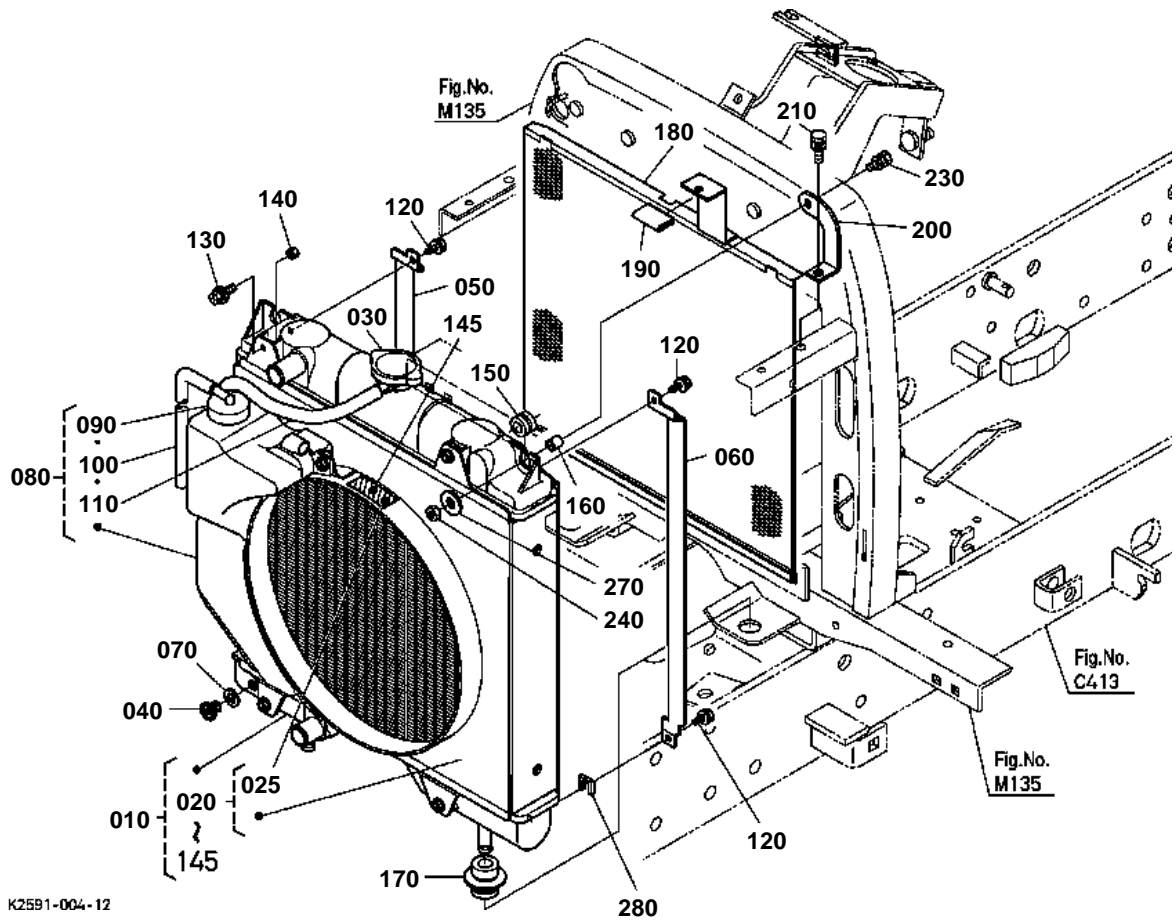

# OLD PARTS

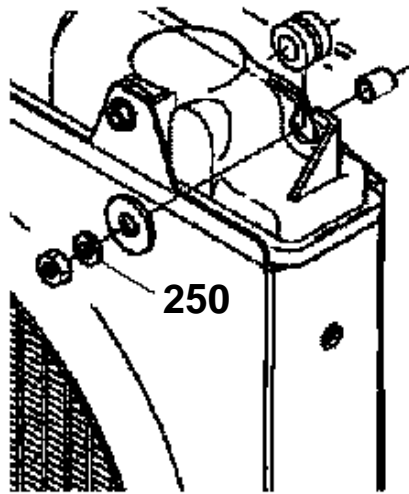
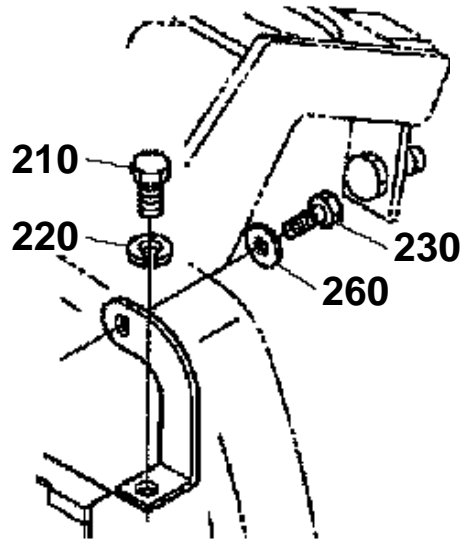

K2591-802-11

**RADIATOR**

↔ Interchangeable; ≠ not interchangeable; ← new for old; → old for new

REF.No	Part No.	Description	Q'ty	S.No.	I/C	REMARKS	Weight (kgf)	Weight (lb)
010	K2561-98510	KIT RADIATOR(D905)	1				4	8.8
020	K2561-98520	KIT SHROUD(D905)	1				0.9	1.98
025	6C090-49580	LABEL FAN WARNING	1				0.005	0.011
030	56930-25870	ASSY CAP	1				0.04	0.088
040	K2561-85250	COCK DRAIN	1				0.002	0.0044
050	K2561-85230	NET GUIDE RH	1				0.08	0.176
060	K2561-85240	NET GUIDE LH	1				0.08	0.176
070	16851-96690	GASKET	1				0.002	0.0044
080	K1211-85280	ASSY TANK RESERVE	1				0.22	0.484
090	16851-72420	CAP	1				0.05	0.11
100	16851-72440	PIPE OVER FLOW	1				0.04	0.088
110	K1211-85290	PIPE WATER OVER FLOW	1				0.04	0.088
120	16851-93710	SCREW	4				0.03	0.066
130	01205-50616	BOLT	7				0.007	0.0154
140	K1211-85270	NUT	4				0.003	0.0066
145	6C090-49580	LABEL FAN WARNING	1				0.005	0.011
150	K2561-85020	CUSHION UPPER	1				0.009	0.0198
160	K2561-85040	COLLAR	1				0.005	0.011
170	16851-72190	CUSHION UNDER	2				0.05	0.11
180	K2561-85414	NET RADIATOR	1				0.37	0.814
190	K2561-85420	COVER	1				0.01	0.022
200	K2561-85430	STAY RADIATOR	1				0.039	0.0858
210	01123-50820	BOLT	1				0.011	0.0242
230	01025-50625	BOLT	1				0.01	0.022
240	02014-50060	NUT	1				0.002	0.0044
270	75599-32111	WASHER PLAIN W	1				0.002	0.0044
270	04015-60060	WASHER PLAIN	1			↔	0.005	0.011
280	K2561-57360	SPONGE BOSS	2				0.001	0.0022

BATTERY

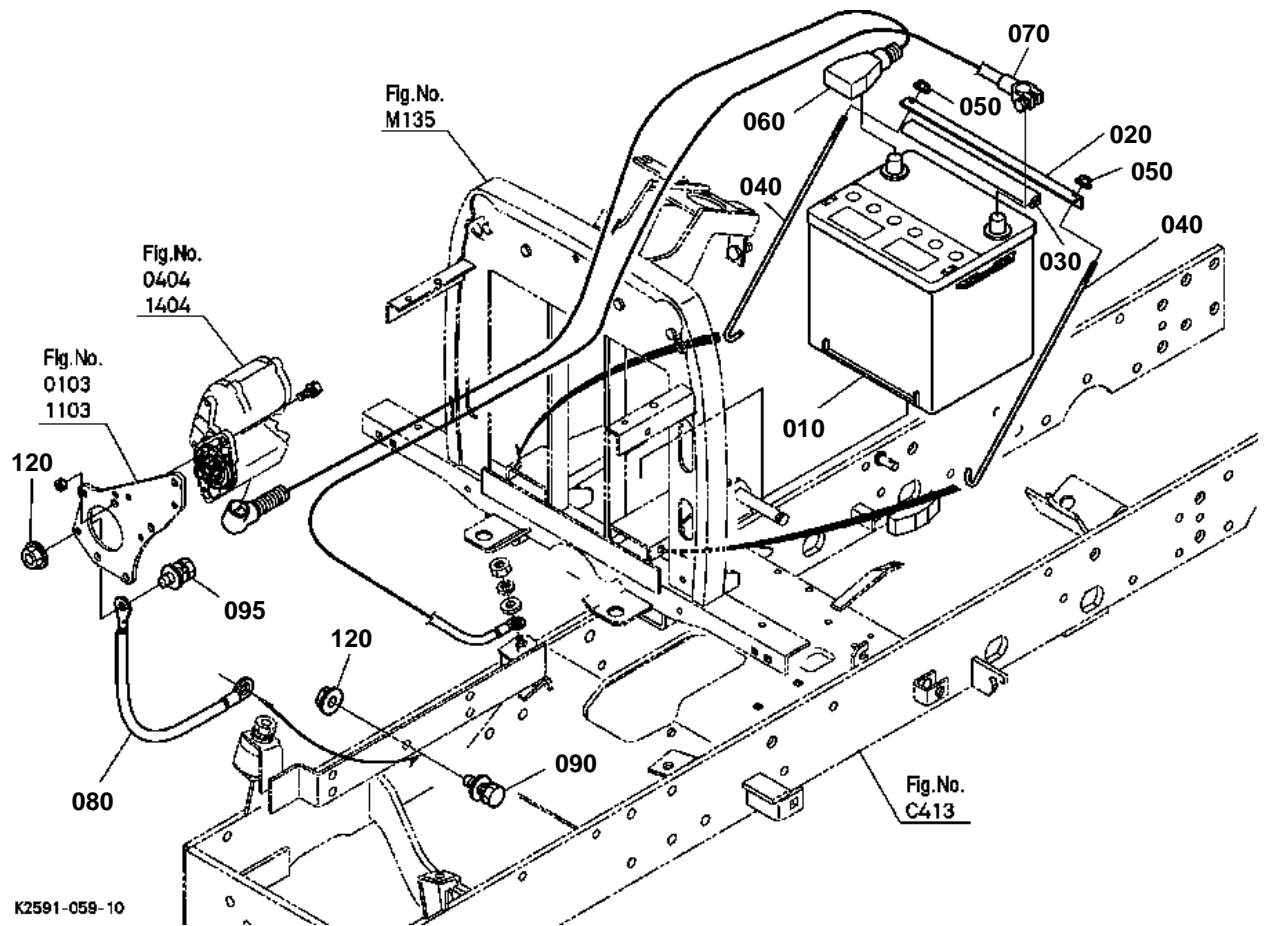



# OLD PARTS

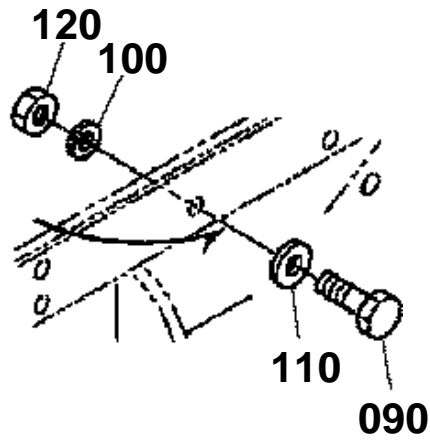
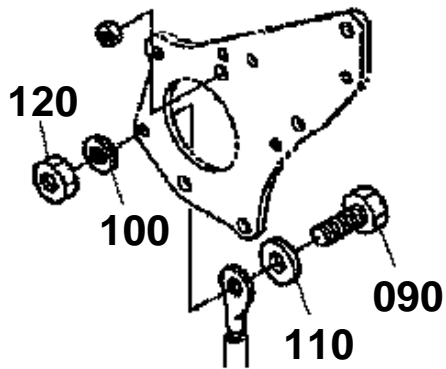

K2591-821-11

**BATTERY**

↔ Interchangeable; ≠ not interchangeable; ← new for old; → old for new

REF.No	Part No.	Description	Q'ty	S.No.	I/C	REMARKS	Weight (kgf)	Weight (lb)
010	K2563-61110	BATTERY F/FA	1				0	0
020	K2561-61120	HOLDER BATTERY	1				0.172	0.3784
030	K2561-61160	TRIM BATTERY	1				0.03	0.066
040	K2561-61130	ROD BATTERY	2				0.05	0.11
050	02751-50060	NUT FLANGE	2				0.005	0.011
060	K2561-61310	CABLE BATTERY(+)	1				0.32	0.704
070	K2561-61350	CABLE BATTERY(-)	1				0.271	0.5962
080	K1211-61360	CABLE BATTERY(-)	1				0.05	0.11
090	01125-50825	BOLT	1				0.018	0.0396
095	01125-60820	BOLT	1				0.015	0.033
120	02751-50080	NUT FLANGE	2				0.006	0.0132

PANEL BOARD

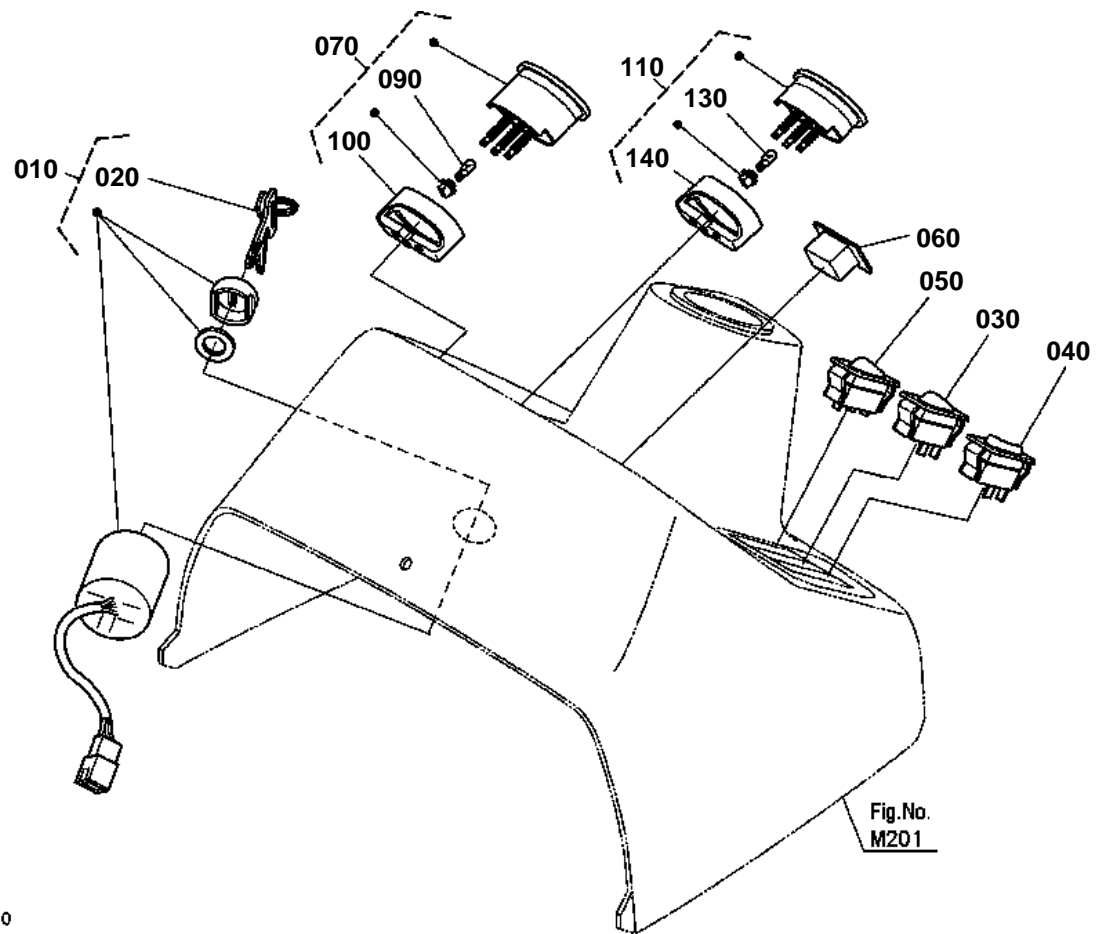

K2591-082-10



# PANEL BOARD

↔ Interchangeable; ≠ not interchangeable; ← new for old; → old for new

REF.No	Part No.	Description	Q'ty	S.No.	I/C	REMARKS	Weight (kgf)	Weight (lb)
010	66101-55200	ASSY SWITCH STARTER	1				0.3	0.66
020	37410-55150	KEY STARTER	1				0.025	0.055
030	K1122-62210	SWITCH LIGHT	1				0.018	0.0396
040	K2561-62220	SWITCH FLASHER	1				0.019	0.0418
050	K2561-62230	SWITCH HAZARD	1				0.022	0.0484
060	K2561-62510	METER HOUR	1				0.12	0.264
070	K2561-62520	ASSY METER FUEL	1				0.1	0.22
080	99999-99999	BLANK	0				0	0
090	K2561-62580	BULB LAMP METER	1				0.002	0.0044
100	K2561-62590	CLAMP FUEL	1				0.022	0.0484
110	K2561-62530	ASSY METER THERMO	1				0.08	0.176
120	99999-99999	BLANK	0				0	0
130	K2561-62580	BULB LAMP METER	1				0.002	0.0044
140	K2561-62590	CLAMP FUEL	1				0.022	0.0484

SWITCH/SENSOR

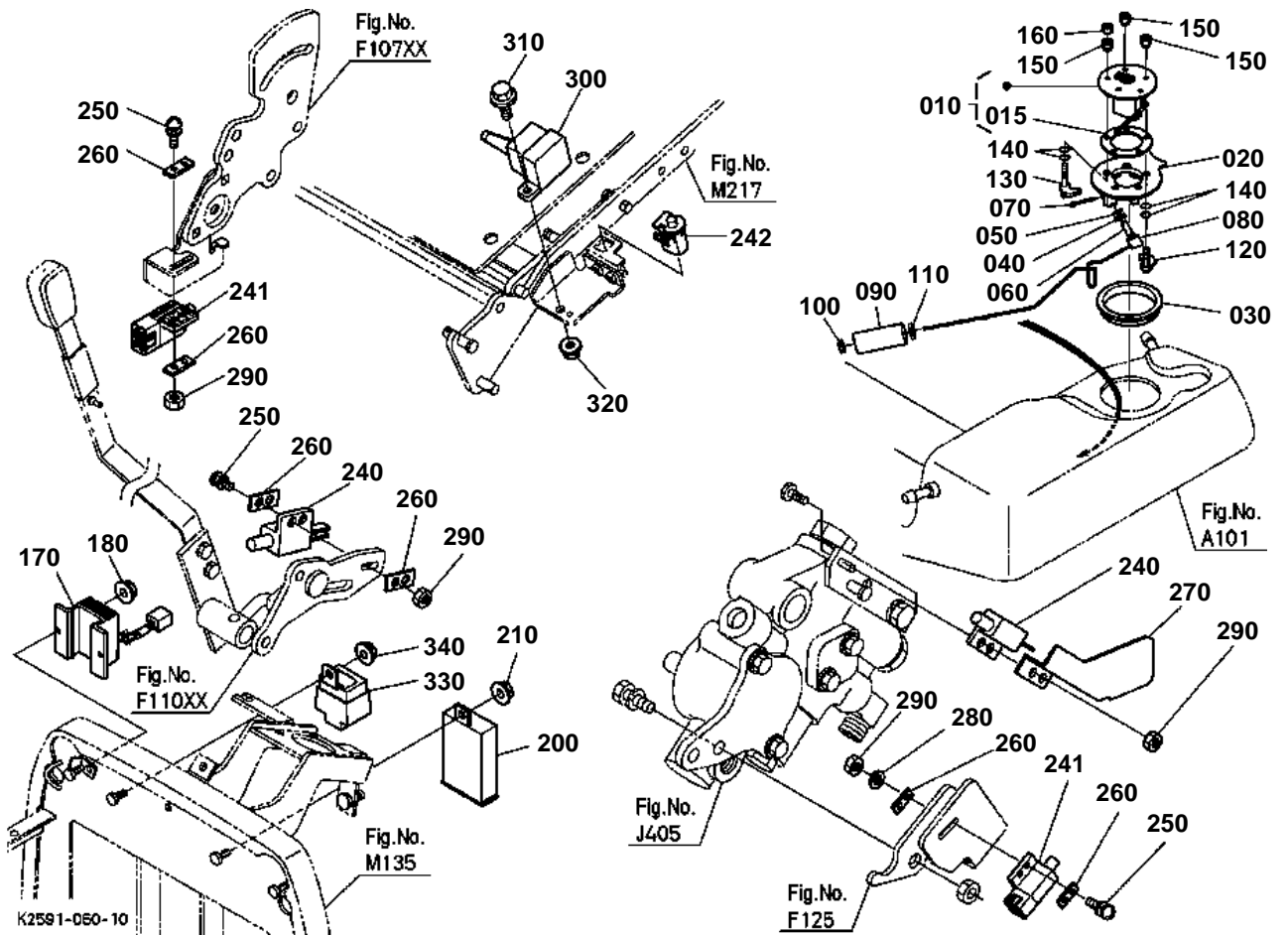

# OLD PARTS

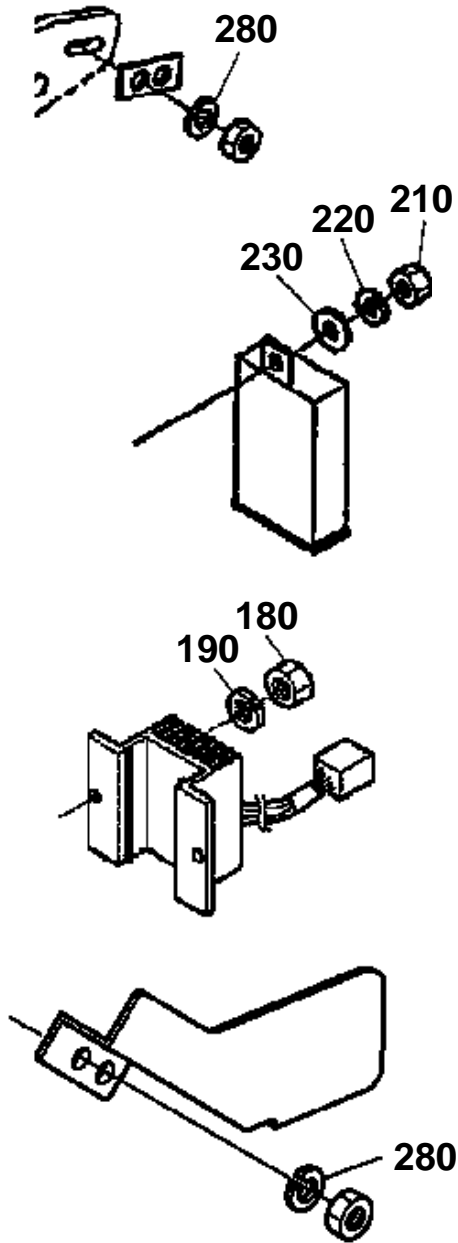

K2591-822-11

**SWITCH/SENSOR**

↔ Interchangeable; ≠ not interchangeable; ← new for old; → old for new

REF.No	Part No.	Description	Q'ty	S.No.	I/C	REMARKS	Weight (kgf)	Weight (lb)
010	K2561-61370	SENSOR FUEL	1				0.12	0.264
015	6A100-54790	GASKET GAUGE	1				0.01	0.022
020	K2561-61386	STAY SENSOR FUEL	1				0	0
030	K2561-61392	BUSH SENSOR FUEL	1				0.02	0.044
040	K2561-61440	BEARING BALL	1				0.003	0.0066
050	04611-00160	CIR CLIP INTERNAL	1				0.001	0.0022
060	K2561-61460	PIN JOINT	1				0.012	0.0264
070	05511-50218	PIN SPLIT	1				0.001	0.0022
080	K2561-61413	ARM FUEL FLOAT	1				0.04	0.088
090	K2561-61420	FLOAT LEVELER FUEL	1				0.016	0.0352
100	K2561-61430	WASHER	1				0.001	0.0022
110	K2561-61450	WASHER PLAIN	1				0.001	0.0022
120	K2561-61480	BOLT CLAMP	4				0.007	0.0154
130	K2561-61490	BOLT CLAMP L	1				0.009	0.0198
140	04816-00050	O RING	10				0.001	0.0022
150	02552-50050	NUT LOCK	5				0.013	0.0286
160	02054-50050	NUT	1				0.002	0.0044
170	K2561-62050	REGULATOR	1				0.25	0.55
180	02751-50060	NUT FLANGE	2				0.005	0.011
200	3F240-75430	UNIT FLASHER	1				0.06	0.132
210	02751-50060	NUT FLANGE	1				0.005	0.011
240	K2561-62250	SWITCH SAFETY	2				0.017	0.0374
241	K1122-62250	SWITCH SAFETY	2				0.02	0.044
242	K1122-62280	SWITCH SEAT	1				0.011	0.0242
250	03024-50420	SCREW WITH WASHER	6				0.002	0.0044
260	K2561-62260	PLATE SWITCH	6				0.001	0.0022
270	K2561-62270	BRACKET SWITCH	1				0.023	0.0506
280	04512-60040	WASHER SPRING	2				0.002	0.0044
290	02054-50040	NUT	8				0.001	0.0022
300	TD060-47902	SWITCH SEAT	1				0.03	0.066
310	01754-50616	BOLT FLANGE	1				0.006	0.0132
320	02751-50060	NUT FLANGE	1				0.005	0.011
330	T0070-31410	TIMER KEY STOP	1				0.065	0.143
340	02751-50060	NUT FLANGE	1				0.005	0.011

HEAD RIGHT

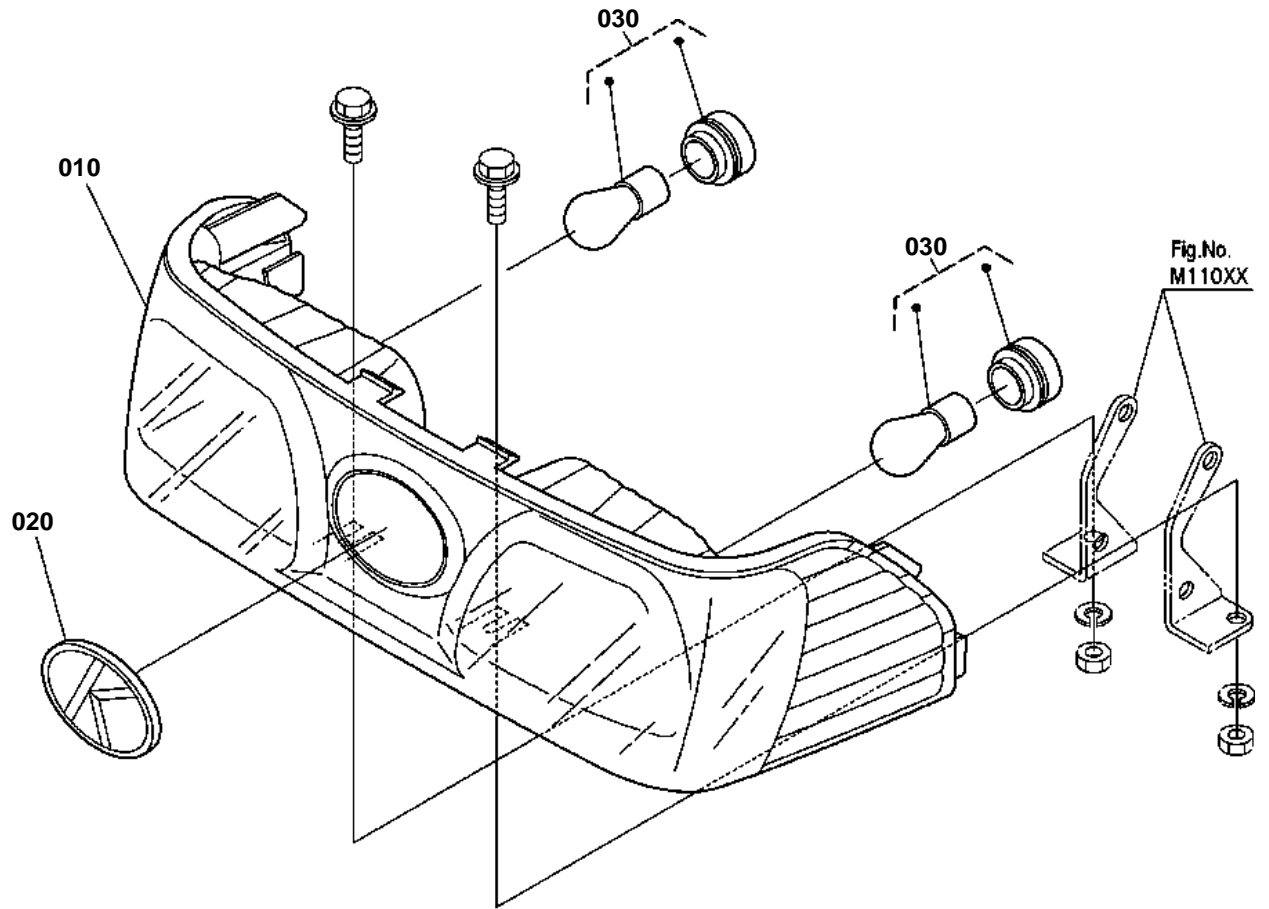

K2591-106-10





# HEAD RIGHT

↔ Interchangeable; ≠ not interchangeable; ← new for old; → old for new

REF.No	Part No.	Description	Q'ty	S.No.	I/C	REMARKS	Weight (kgf)	Weight (lb)
010	K2571-54310	ASSY LAMP HEAD	1				0	0
020	T1060-49500	MARK SYMBOL	1				0.01	0.022
030	K2571-54320	ASSY VALVE	2				0	0

HAZARD LIGHT/TAIL LIGHT

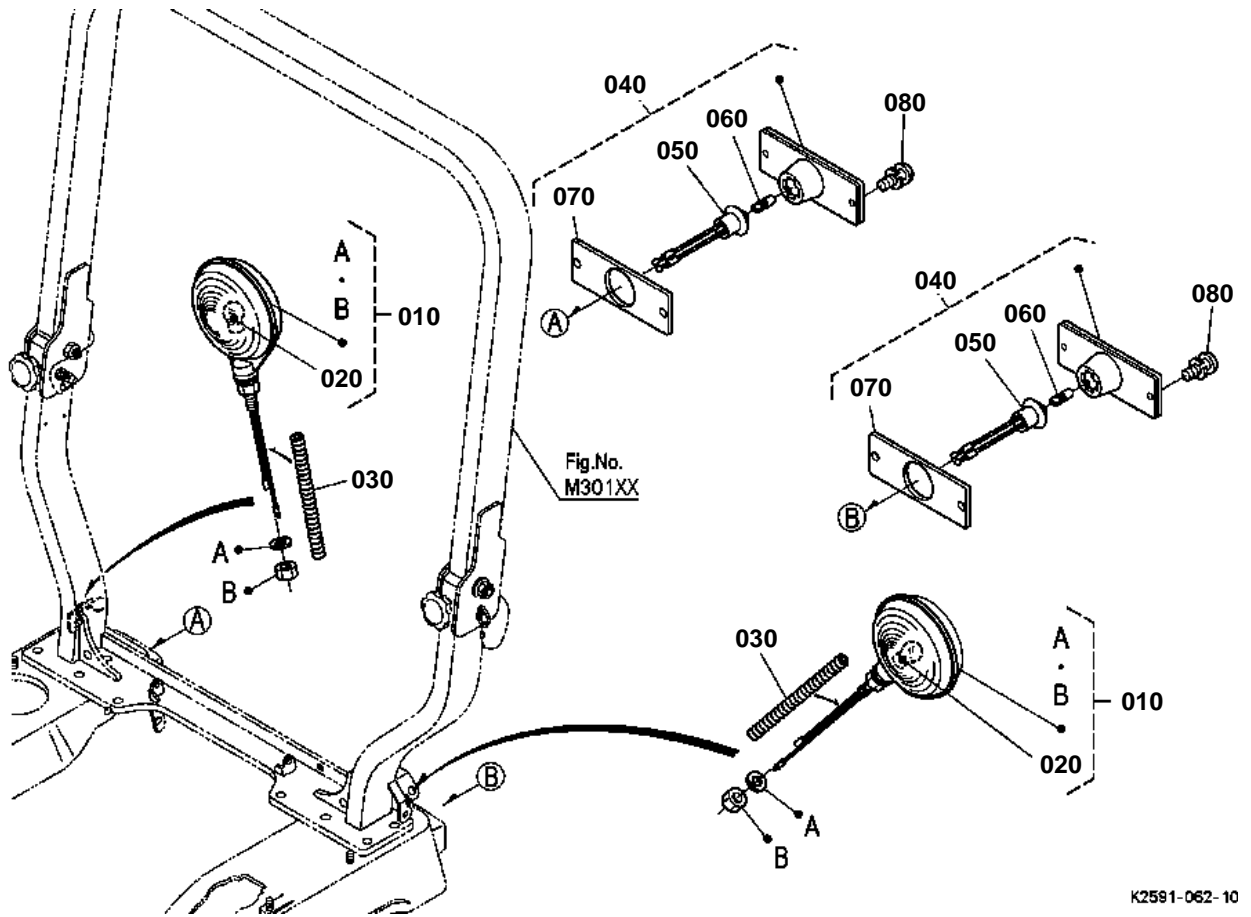

K2591-062-10

## OLD PARTS

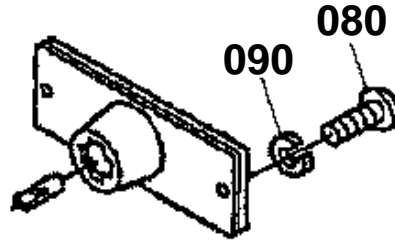

K2591-804-11



# HAZARD LIGHT/TAIL LIGHT

↔ Interchangeable; ≠ not interchangeable; ← new for old; → old for new

REF.No	Part No.	Description	Q'ty	S.No.	I/C	REMARKS	Weight (kgf)	Weight (lb)
010	K2561-62610	ASSY LAMP HAZARD	2				0.2	0.44
020	K2561-62650	BULB LAMP	2			NOT SALE	0	0
030	K2561-62620	TUBE GUARD HAZARD	2				0.009	0.0198
040	K2561-62710	ASSY LIGHT TAIL	2				0.108	0.2376
050	K2561-62730	SOCKET TAIL LAMP	2			NOT SALE	0	0
060	K2561-62740	BULB TAIL LAMP	2			NOT SALE	0	0
070	K2561-62750	GASKET TAIL LAMP	2				0	0
080	03024-50425	SCREW WITH WASHER	4				0.003	0.0066





## WINKER LAMP

↔ Interchangeable; ≠ not interchangeable; ← new for old; → old for new

REF.No	Part No.	Description	Q'ty	S.No.	I/C	REMARKS	Weight (kgf)	Weight (lb)
010	K2561-62630	LAMP TURN SIGNAL	2				0.12	0.264
020	37410-52710	ASSY BODY	2				0.055	0.121
030	37410-52720	BULB	2				0.02	0.044
040	37410-52730	LENS	4				0.025	0.055
050	37410-52740	GASKET	2				0.025	0.055
060	02116-50100	NUT	2				0.004	0.0088
070	04411-50100	WASHER TOOTHED	2				0.001	0.0022

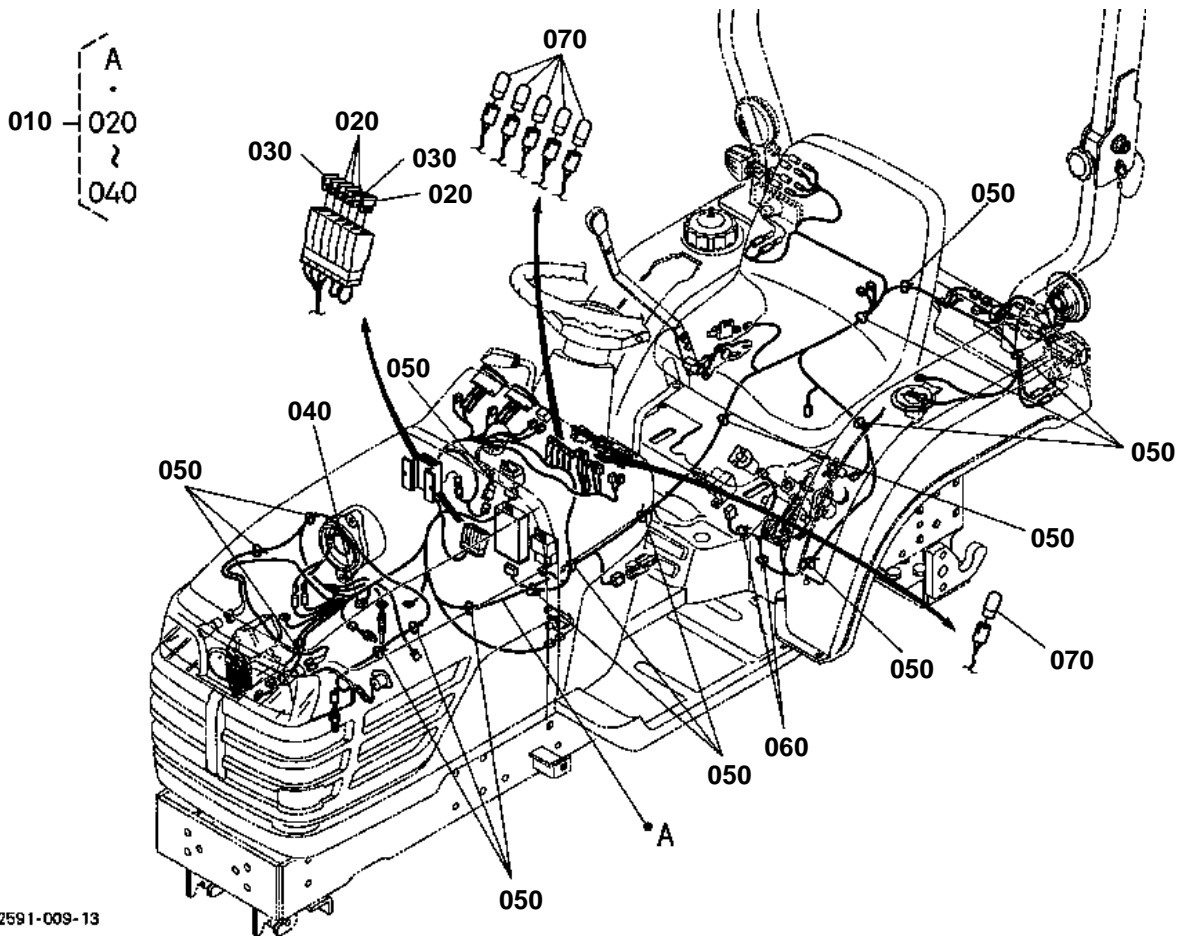

K2591-009-13



# ELECTRICAL WIRING

↔ Interchangeable; ≠ not interchangeable; ← new for old; → old for new

REF.No	Part No.	Description	Q'ty	S.No.	I/C	REMARKS	Weight (kgf)	Weight (lb)
010	K2591-63222	ASSY WIRE HARNESS	1				0	0
020	35820-75560	FUSE	4			15A	0.002	0.0044
030	36919-56650	FUSE	2			20A	0.002	0.0044
040	51950-29320	FUSE	1			30A	0.005	0.011
050	K1122-61230	CLAMP CORD	16				0.001	0.0022
060	13824-67580	CLAMP CORD	2				0.006	0.0132
070	K1142-62350	BULB	6				0.01	0.022



FRONT FRAME

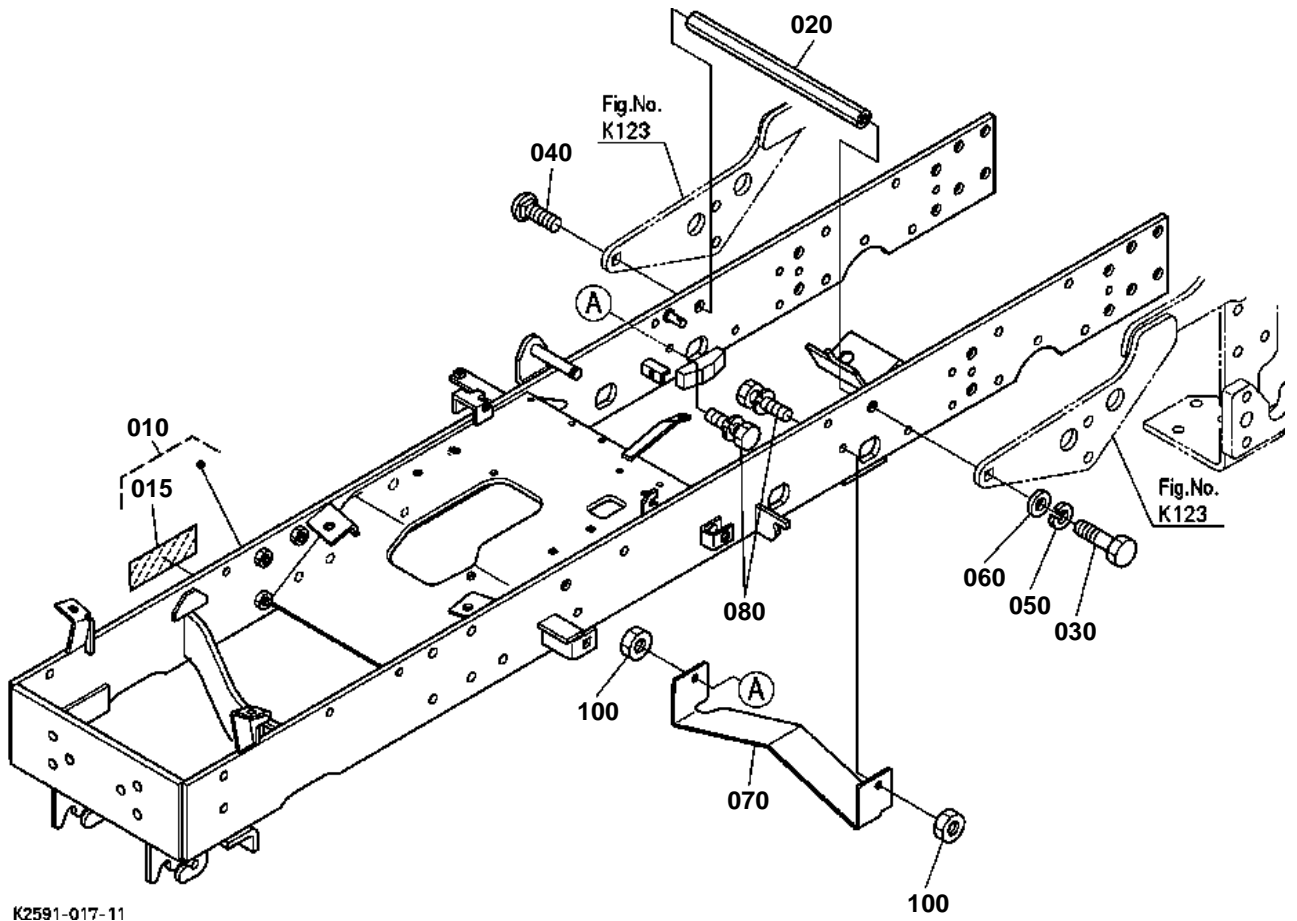

K2591-017-11

# OLD PARTS

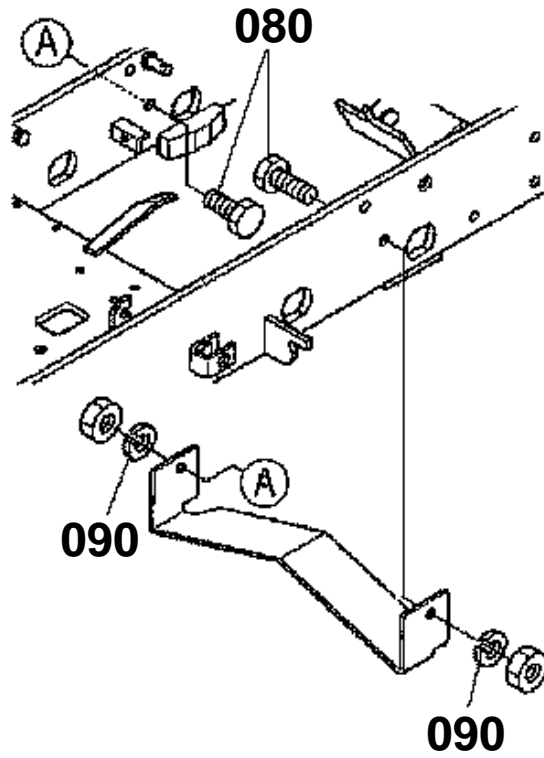

K2591-840-10



FRONT FRAME

↔ Interchangeable; ≠ not interchangeable; ← new for old; → old for new

REF.No	Part No.	Description	Q'ty	S.No.	I/C	REMARKS	Weight (kgf)	Weight (lb)
010	K2591-92110	KIT FRAME COMP	1			ENGLISH	102	224.4
010	K2597-92110	KIT FRAME COMP	1			FRENCH	120	264
015	K2561-65410	LABEL START DANGER	1			ENGLISH NOT SALE	0	0
015	K2567-65410	LABEL START DANGER F	1			FRENCH NOT SALE	0	0
020	K2591-21030	ROD TIE	1				0.5	1.1
030	01073-51450	BOLT	1				0.08	0.176
040	K2591-21150	BOLT	1				0.08	0.176
050	75599-33016	WASHER SPRING	1				0.08	0.176
050	04512-60140	WASHER SPRING	1		↔		0.008	0.0176
060	75599-32516	WASHER PLAIN	1				0.011	0.0242
070	K2561-21212	COVER HST FAN	1				0.6	1.32
080	01133-51030	BOLT	2				0.025	0.055
100	02118-50100	NUT	2				0.005	0.011

# SUB FRAME

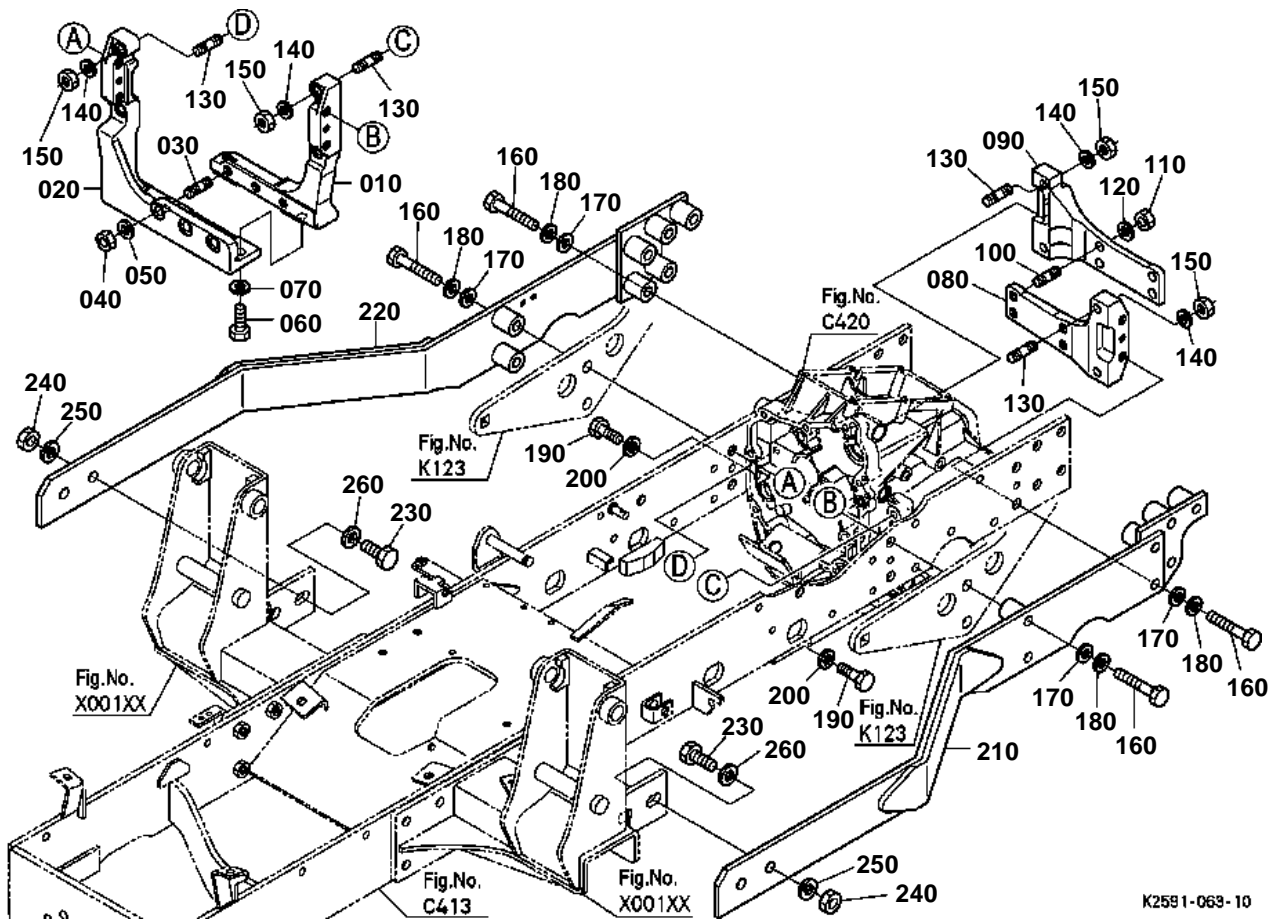

K2591-069-10

# OLD PARTS

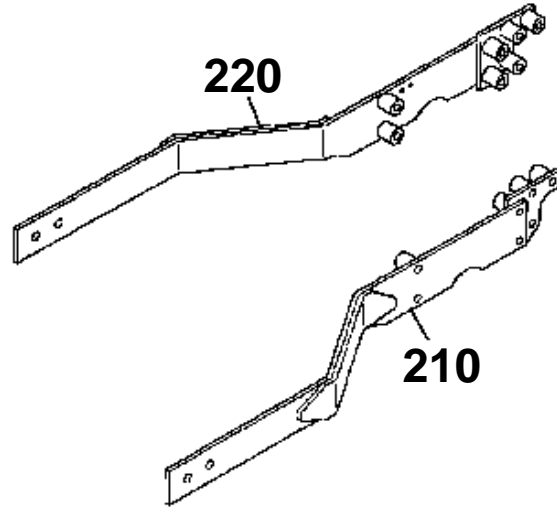

K2591-845-10

**SUB FRAME**

↔ Interchangeable; ≠ not interchangeable; ← new for old; → old for new

REF.No	Part No.	Description	Q'ty	S.No.	I/C	REMARKS	Weight (kgf)	Weight (lb)
010	K2591-21520	BRACKET FRONT LH	1				3.7	8.14
020	K2591-21620	BRACKET FRONT RH	1				3.7	8.14
030	K2591-21540	STUD	3				0.046	0.1012
040	02074-50140	NUT	3				0.021	0.0462
050	75599-33016	WASHER SPRING	3				0.08	0.176
050	04512-60140	WASHER SPRING	3		↔		0.008	0.0176
060	01073-51440	BOLT	2				0.069	0.1518
070	75599-33016	WASHER SPRING	2				0.08	0.176
070	04512-60140	WASHER SPRING	2		↔		0.008	0.0176
080	K2591-21530	BRACKET REAR LH	1				2.64	5.808
090	K2591-21630	BRACKET REAR RH	1				2.2	4.84
100	K2591-21540	STUD	4				0.046	0.1012
110	02074-50140	NUT	4				0.021	0.0462
120	75599-33016	WASHER SPRING	4				0.08	0.176
120	04512-60140	WASHER SPRING	4		↔		0.008	0.0176
130	01555-51245	STUD	8				0.26	0.572
140	04512-60120	WASHER SPRING	8				0.005	0.011
150	02174-50120	NUT	8				0.01	0.022
150	K2561-21550	NUT	8		↔		0.013	0.0286
160	01073-51480	BOLT	8				0.01	0.022
170	75599-32516	WASHER PLAIN	8				0.011	0.0242
180	75599-33016	WASHER SPRING	8				0.08	0.176
180	04512-60140	WASHER SPRING	8		↔		0.008	0.0176
190	01053-51240	BOLT	10				0.05	0.11
200	04512-60120	WASHER SPRING	10				0.005	0.011
210	K2591-26113	FRAME SUB L	1				10.8	23.76
220	K2591-26124	FRAME SUB R	1				10.8	23.76
230	75599-04735	HEX.BOLT	4				0.09	0.198
240	75599-31067	HEX.NUT	4				0.032	0.0704
250	75599-33017	WASHER SPRING	4				0.005	0.011
250	04512-60160	WASHER SPRING	4		↔		0.01	0.022
260	75599-32517	WASHER PLAIN	4				0.016	0.0352

ENGINE SUPPORT

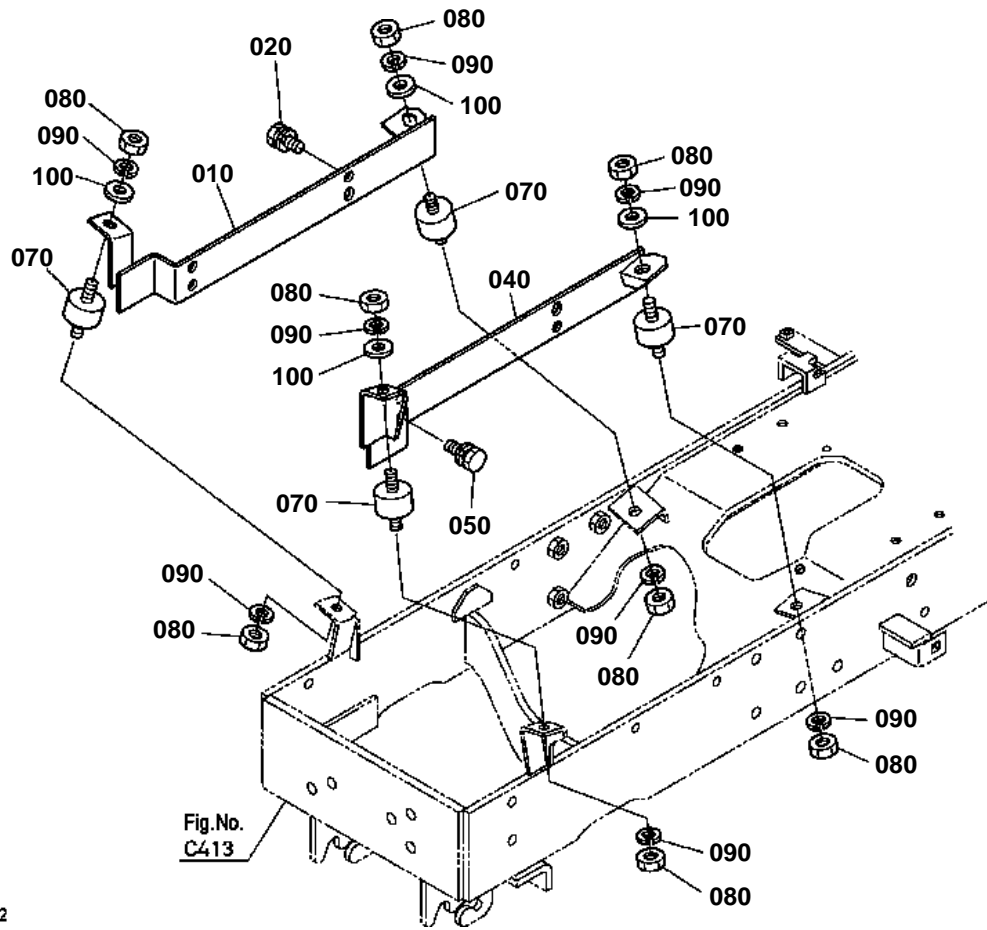

K2591-019-12

# OLD PARTS

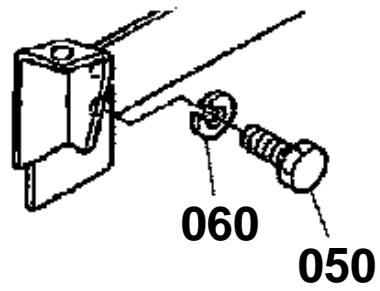
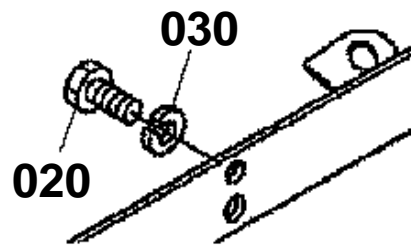

K2591-824-11





## ENGINE SUPPORT

↔ Interchangeable; ≠ not interchangeable; ← new for old; → old for new

REF.No	Part No.	Description	Q'ty	S.No.	I/C	REMARKS	Weight (kgf)	Weight (lb)
010	K2561-22120	SUPPORT ENGINE RH	1				1.6	3.52
020	01133-51022	BOLT	4				0.025	0.055
040	K2561-22110	SUPPORT ENGINE LH	1				1.6	3.52
050	01133-51022	BOLT	4				0.025	0.055
070	K2561-22130	CUSHION	4				0.05	0.11
080	75599-31013	NUT	8				0.006	0.0132
090	75599-33013	WASHER SPRING	8				0.006	0.0132
100	75599-32013	WASHER PLAIN	4				0.03	0.066
100	04013-60100	WASHER PLAIN	4		↔		0.003	0.0066

TRANSMISSION CASE

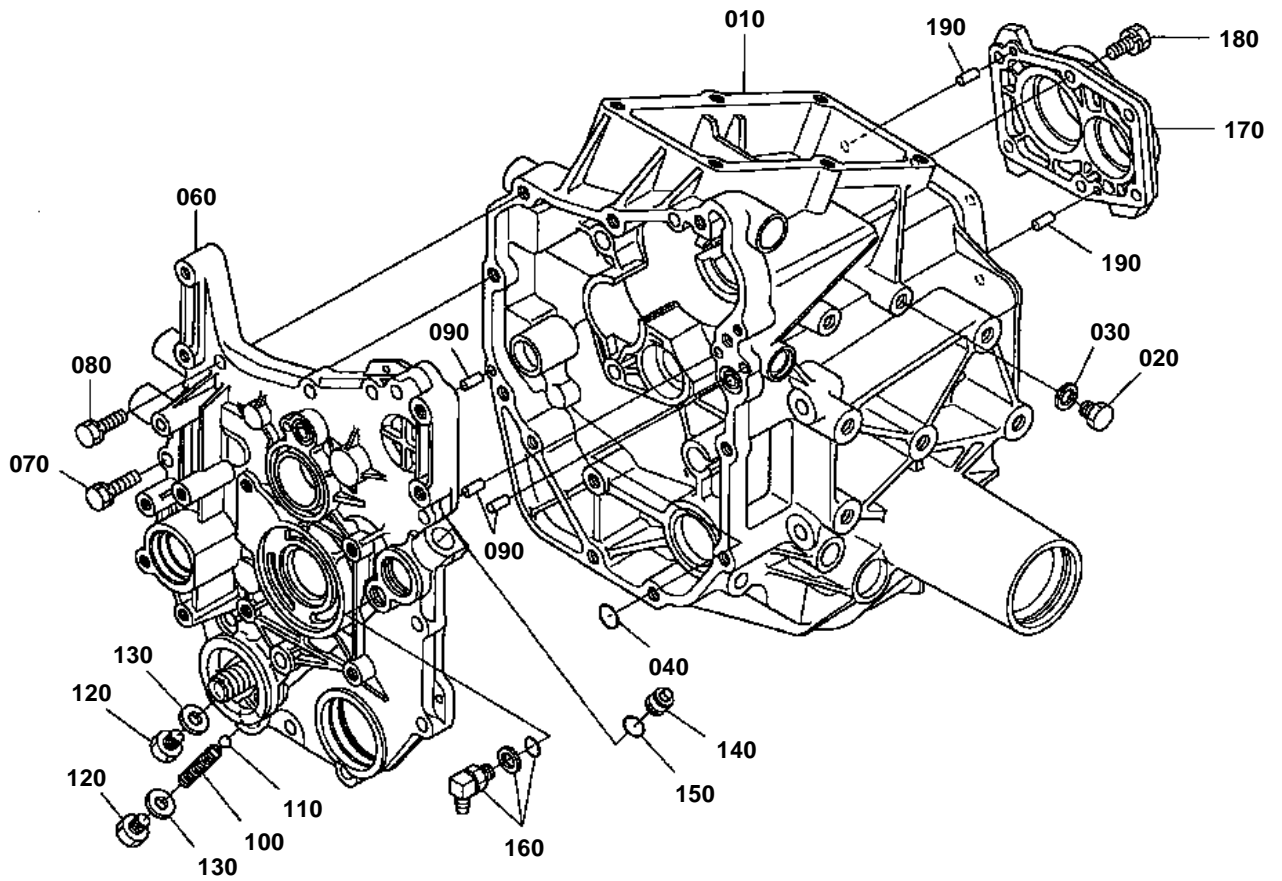

K2553-011-11



## TRANSMISSION CASE

↔ Interchangeable; ≠ not interchangeable; ← new for old; → old for new

REF.No	Part No.	Description	Q'ty	S.No.	I/C	REMARKS	Weight (kgf)	Weight (lb)
010	K2561-11016	CASE TRANSMISSION	1				10.7	23.54
020	06331-35014	PLUG	1				0.03	0.066
030	04717-01400	WASHER WITH RUBBER	1				0.003	0.0066
040	04817-00160	O RING	1				0.001	0.0022
050	99999-99999	BLANK	0				0	0
060	K2561-11114	COVER FRONT	1				2.6	5.72
070	01123-51060	BOLT	2				0.05	0.11
080	01123-51040	BOLT	9				0.03	0.066
090	05012-00614	PIN STRAIGHT	3				0.004	0.0088
100	K2561-11180	SPRING PTO	1				0.005	0.011
110	07715-03211	BALL	1				0.003	0.0066
120	06331-35014	PLUG	2				0.03	0.066
130	04717-01400	WASHER WITH RUBBER	2				0.003	0.0066
140	K2561-11140	PLUG	1				0.034	0.0748
150	04816-00140	O RING	1				0.002	0.0044
160	K2561-36630	CONNECTOR	1				0.06	0.132
170	K2561-11212	COVER REAR	1				0.38	0.836
180	01123-51030	BOLT	6				0.025	0.055
190	05012-00614	PIN STRAIGHT	2				0.004	0.0088

REAR AXLE CASE

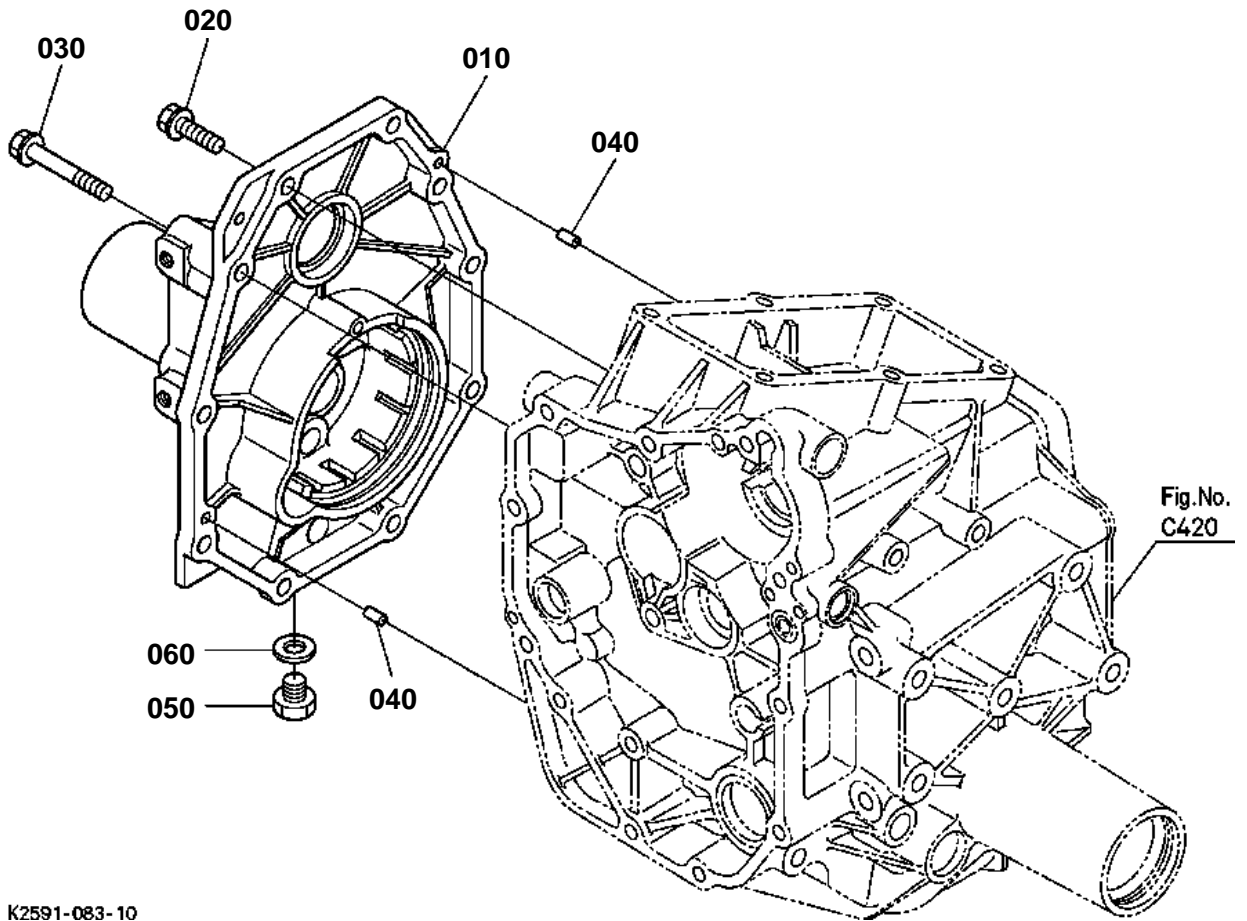

K2591-083-10



## REAR AXLE CASE

↔ Interchangeable; ≠ not interchangeable; ← new for old; → old for new

REF.No	Part No.	Description	Q'ty	S.No.	I/C	REMARKS	Weight (kgf)	Weight (lb)
010	K2561-11023	COVER AXLE R	1				3	6.6
020	01123-51040	BOLT	8				0.03	0.066
030	01123-51080	BOLT	2				0.051	0.1122
040	05012-00614	PIN STRAIGHT	2				0.004	0.0088
050	06331-35012	PLUG	1				0.022	0.0484
060	04717-01200	WASHER WITH RUBBER	1				0.002	0.0044

CLUTCH SHAFT/OUTPUT SHAFT

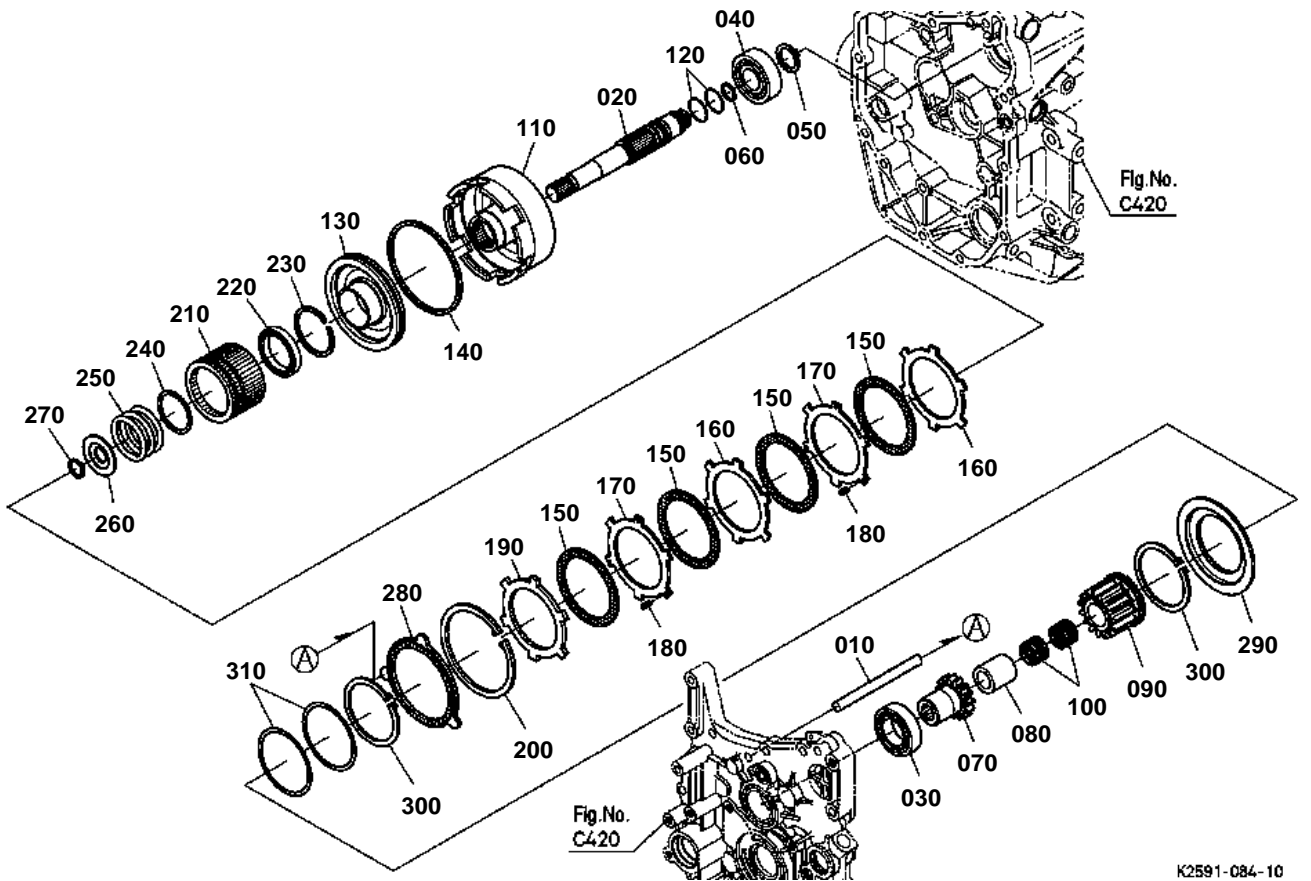

K2591-084-10



# CLUTCH SHAFT/OUTPUT SHAFT

↔ Interchangeable; ≠ not interchangeable; ← new for old; → old for new

REF.No	Part No.	Description	Q'ty	S.No.	I/C	REMARKS	Weight (kgf)	Weight (lb)
010	K2561-11130	SAHFT BRAKE DISK	1				0.05	0.11
020	K2561-11310	SHAFT CLUTCH	1				0.33	0.726
030	08101-06005	BEARING BALL	1				0.157	0.3454
040	08101-06204	BEARING BALL	1				0.102	0.2244
050	04612-00200	CIR CLIP EXTERNAL	1				0.001	0.0022
060	37410-75320	RING SEAL	1				0.01	0.022
070	K2561-11320	GEAR	1			13T	0.12	0.264
080	K2561-11330	COLLAR SPACER	1				0.08	0.176
090	K2561-11340	GEAR CLUTCH	1			12T	0.001	0.0022
100	08821-82213	BEARING NEEDLE	2				0.009	0.0198
110	K2561-11353	CASE CLUTCH	1				0.56	1.232
120	04816-05190	O RING	2				0.002	0.0044
130	K2561-11363	PISTON CLUTCH	1				0.26	0.572
140	37410-75370	D RING	1				0.002	0.0044
150	34070-15250	DISK CLUTCH	4				0.04	0.088
160	TA040-69070	PLATE	2				0.036	0.0792
170	TA040-69080	PLATE	2				0.036	0.0792
180	TA040-69090	RUBBER	6				0.001	0.0022
190	37410-75430	PLATE PRESSURE	1				0.065	0.143
200	04611-00920	CIR CLIP INTERNAL	1				0.04	0.088
210	K2561-13933	BOSS SPLINE CLUTCH	1				0.26	0.572
220	K2561-13960	BEARING BALL	1				0.03	0.066
230	K2561-13970	CIR-CLIP INTERNAL	1				0.004	0.0088
240	K2561-11390	COLLAR BEARING	1				0.005	0.011
250	K2561-11373	SPRING CLUTCH	1				0.045	0.099
260	K2561-11383	COLLAR SPRING	1				0.022	0.0484
270	04612-00220	CIR CLIP EXTERNAL	1				0.001	0.0022
280	K2561-13910	DISK BRAKE	1				0.06	0.132
290	K2561-13922	PRESSURE PLATE BRAKE	1				0.18	0.396
300	04612-00600	CIR CLIP EXTERNAL	2				0.012	0.0264
310	K2561-13940	SHIM BRAKE	2			0.5mm	0.005	0.011

# PROPELLER SHAFT

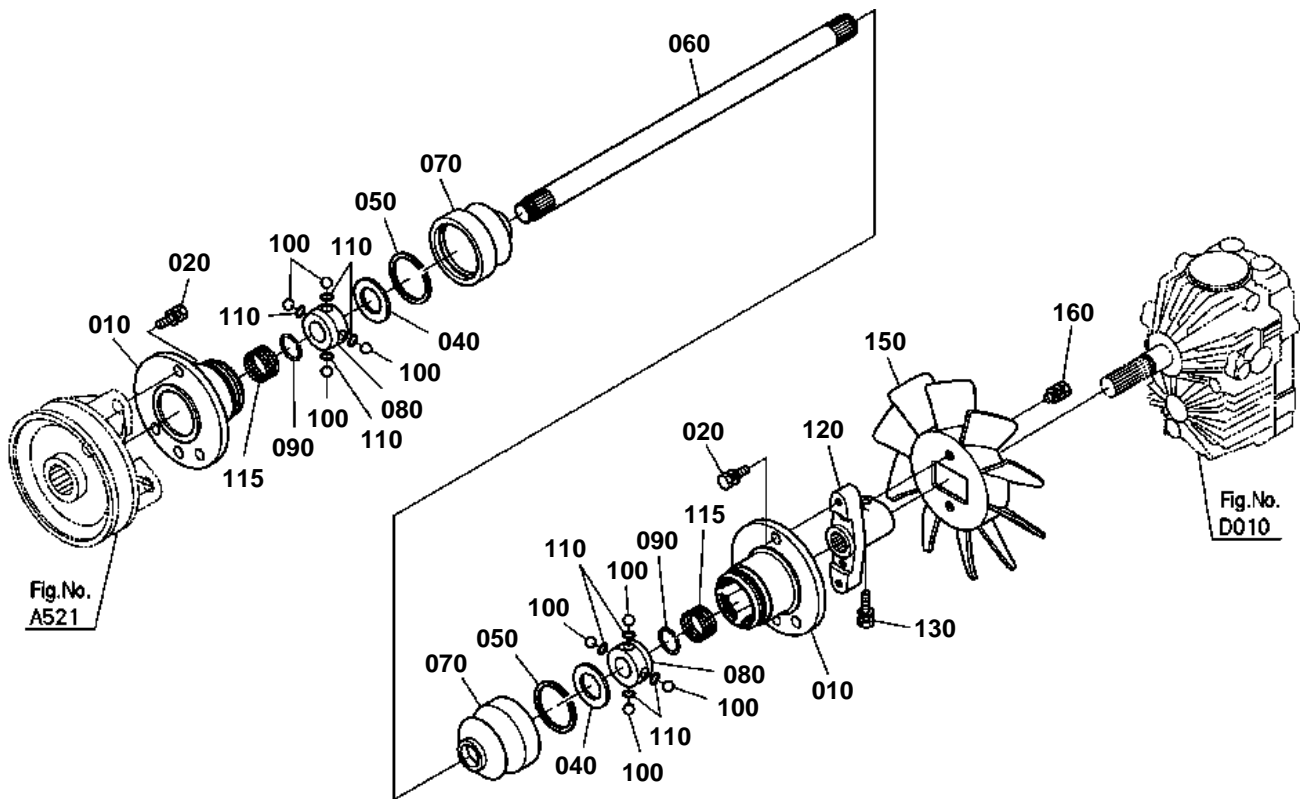

K2591-085-10



# OLD PARTS

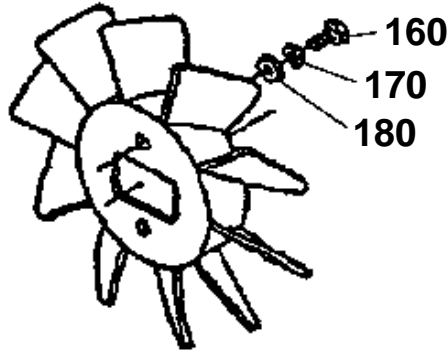
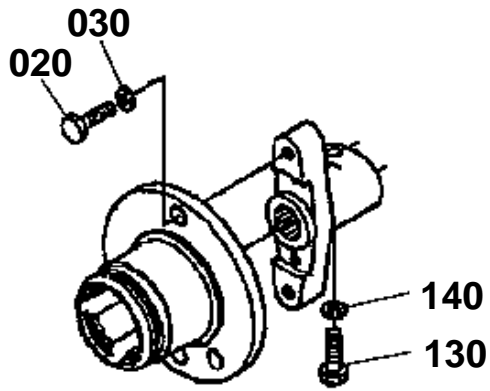

K2591-806-11



## PROPELLER SHAFT

↔ Interchangeable; ≠ not interchangeable; ← new for old; → old for new

REF.No	Part No.	Description	Q'ty	S.No.	I/C	REMARKS	Weight (kgf)	Weight (lb)
010	K2561-14110	COUPLING FRONT	2				0.86	1.892
020	01123-50825	BOLT	5				0.013	0.0286
040	K2561-14150	PLATE BALL JOINT	2				0.015	0.033
050	04611-00380	CIR CLIP INTERNAL	2				0.004	0.0088
060	K2561-14210	SHAFT PROPELLER	1				1.57	3.454
070	K2561-14130	COVER JOINT	2				0.024	0.0528
080	67211-14133	COUPLING BALL INNER	2				0.075	0.165
090	K2561-14140	CIR CLIP EXTERNAL	2				0.001	0.0022
100	07715-00803	BALL	8				0.004	0.0088
110	K2561-14160	O RING DAMPER	8				0.002	0.0044
115	62271-14340	SPRING STRG.CLUTCH	2				0.008	0.0176
120	K2561-14222	COUPLING REAR	1				0.32	0.704
130	01123-50830	BOLT	1				0.015	0.033
150	K2561-14250	FAN HST	1				0.098	0.2156
160	01125-60816	BOLT	2				0.01	0.022

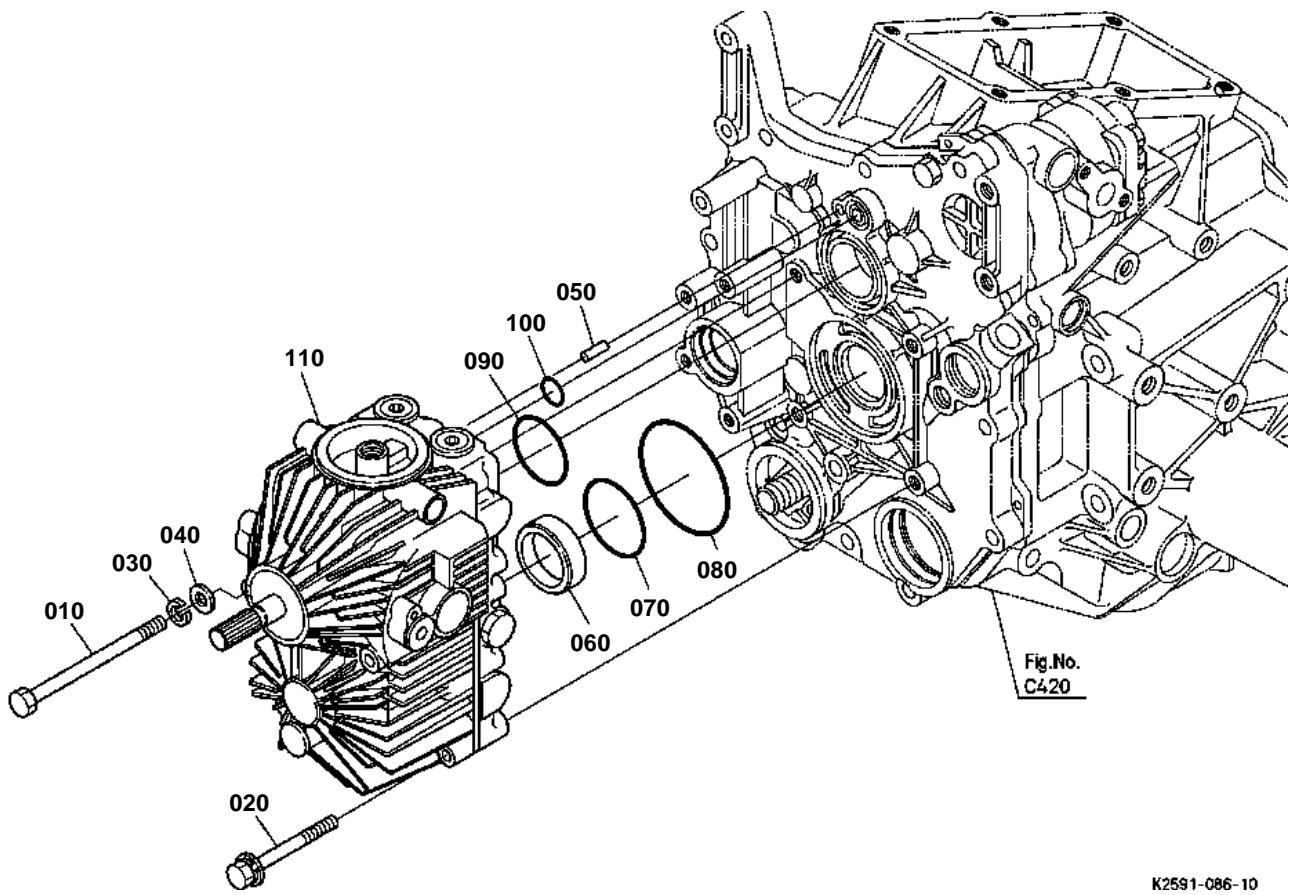

K2591-086-10



HST

↔ Interchangeable; ≠ not interchangeable; ← new for old; → old for new

REF.No	Part No.	Description	Q'ty	S.No.	I/C	REMARKS	Weight (kgf)	Weight (lb)
010	K2561-14010	BOLT HST UPPER	2				0.05	0.11
020	66101-11230	BOLT	2				0.02	0.044
030	04512-60080	WASHER SPRING	2				0.002	0.0044
040	04013-60080	WASHER PLAIN	2				0.002	0.0044
050	05012-00614	PIN STRAIGHT	1				0.004	0.0088
060	K2561-14030	COLLAR	1				0.04	0.088
070	04817-00460	O RING	1				0.003	0.0066
080	04811-07750	O RING	1				0.003	0.0066
090	04817-00480	O RING	1				0.003	0.0066
100	04817-00120	O RING	1				0.001	0.0022
110	K2561-14002	ASSY HST	1				5	11

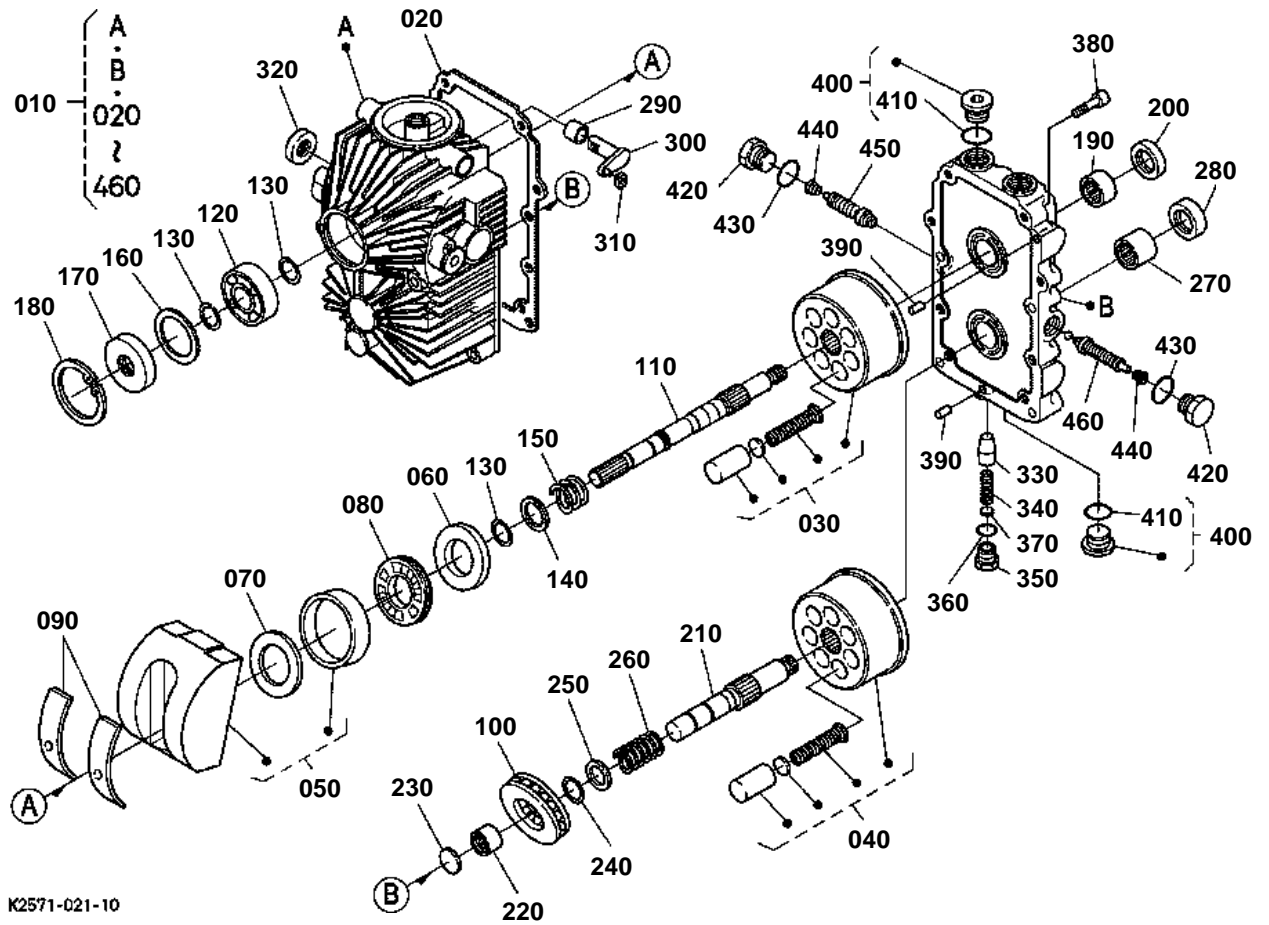

K2571-021-10



# HST [COMPONENT PARTS]

↔ Interchangeable; ≠ not interchangeable; ← new for old; → old for new

REF.No	Part No.	Description	Q'ty	S.No.	I/C	REMARKS	Weight (kgf)	Weight (lb)
010	K2561-14002	ASSY HST	1				5	11
020	66101-36820	GASKET	1				0.005	0.011
030	6C050-98100	KIT CYL-BLOCK PUMP	1				0.92	2.024
040	K2561-14480	KIT CYL-BLOCK MOTOR	1				0.92	2.024
050	6C050-98302	ASSY SWASHPLATE	1				0.5	1.1
060	6C050-98120	PLATE THRUST	1				0.079	0.1738
070	6C050-98130	PLATE THRUST	1				0.038	0.0836
080	6C052-98140	BEARING THRUST	1				0.07	0.154
090	6C050-98752	BEARING CRADLE	2				0.001	0.0022
100	66101-37220	BEARING THRUST BALL	1				0.25	0.55
110	K2561-14610	SHAFT PUMP	1				0.38	0.836
120	K2561-14620	BEARING BALL	1				0.11	0.242
130	66101-37020	CLIP	3				0.001	0.0022
140	66101-37060	WASHER PLAIN	1				0.001	0.0022
150	6C050-98180	SPRING	1				0.011	0.0242
160	K2561-14660	SPACER	1				0.005	0.011
170	66101-36710	SEAL OIL	1				0.02	0.044
180	K2561-14680	CIR CLIP INTERNAL	1				0.007	0.0154
190	K2561-14690	NEEDLE BEARING PUMP	1				0.017	0.0374
200	6C050-98260	SEAL OIL	1				0.006	0.0132
210	K2561-14710	SHAFT MOTOR	1				0.27	0.594
220	66101-37080	BEARING NEEDLE	1				0.015	0.033
230	66101-37230	PLATE	1				0.003	0.0066
240	66101-37020	CLIP	1				0.001	0.0022
250	66101-37060	WASHER PLAIN	1				0.001	0.0022
260	6C050-98180	SPRING	1				0.011	0.0242
270	6C050-98250	BEARING NEEDLE	1				0.053	0.1166
280	66101-36780	SEAL OIL	1				0.01	0.022
290	66101-37340	BEARING JOURNAL	1				0.02	0.044
300	6C050-98650	ARM TRUNNION	1				0.078	0.1716
310	66071-36250	GUIDE THROTTLE	1				0.005	0.011
320	66101-36720	SEAL OIL	1				0.007	0.0154
330	6C050-98420	CONE	1				0.006	0.0132
340	K2561-14840	SPRING	1				0.001	0.0022
350	6C050-98380	PLUG	1				0.014	0.0308
360	6C050-98390	O RING	1				0.001	0.0022
370	6C050-98440	SHIM	1				0.001	0.0022
380	66071-36640	SCREW	8				0.017	0.0374
390	6C050-98510	PIN	2				0.002	0.0044
400	6C050-98400	PLUG SOCKET HEAD	7				0.03	0.066
410	6C050-98340	O RING	7				0.001	0.0022
420	K2561-14930	PLUG CHECK/RELIEF	2				0.05	0.11
430	6C050-98340	O RING	2				0.001	0.0022
440	6C050-98290	SPRING CHECK VALVE	2				0.001	0.0022
450	K2561-14960	ASSY VALVE RELIEF	1				0.021	0.0462
460	K2561-14970	ASSY VALVE RELIEF F	1				0.022	0.0484

# RANGE GEAR SHAFT

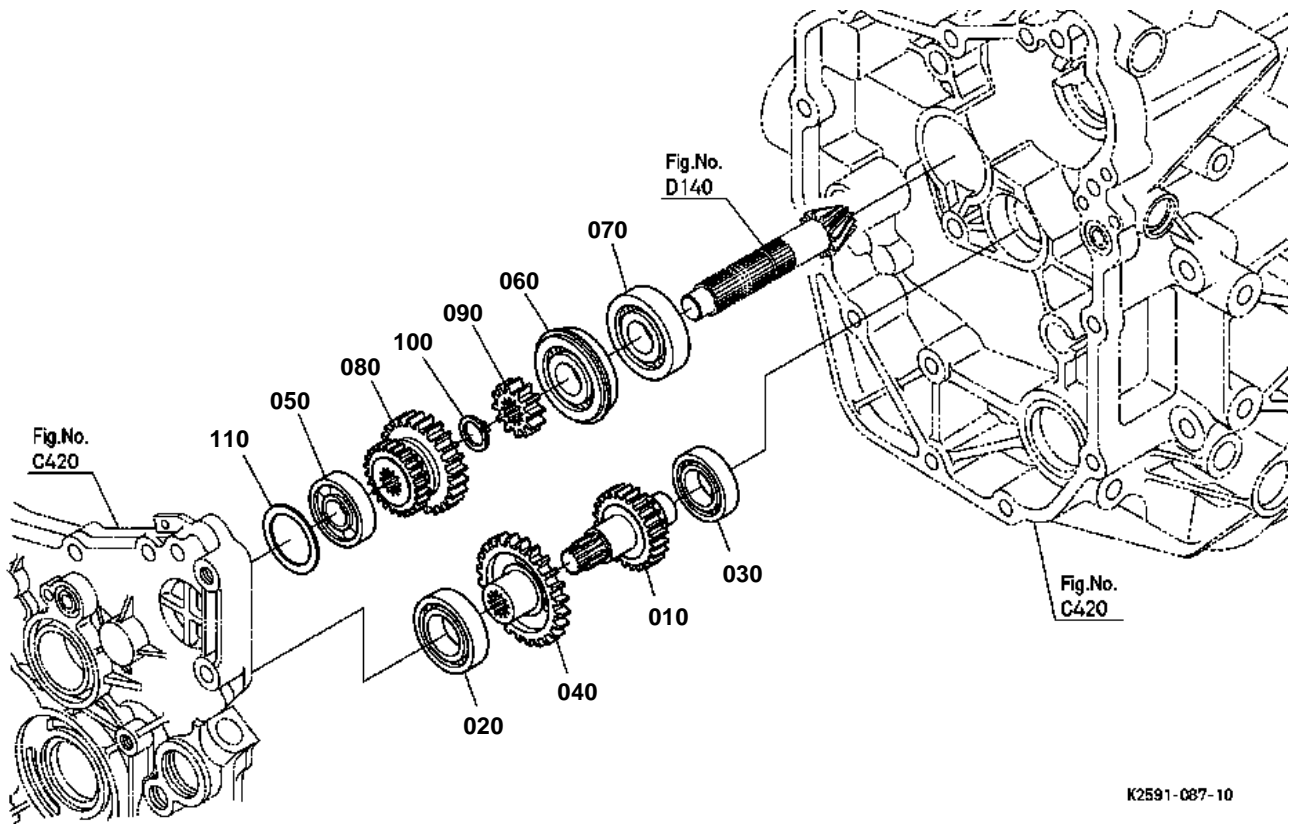

K2591-087-10



# RANGE GEAR SHAFT

↔ Interchangeable; ≠ not interchangeable; ← new for old; → old for new

REF.No	Part No.	Description	Q'ty	S.No.	I/C	REMARKS	Weight (kgf)	Weight (lb)
010	K2561-11810	GEAR LOW	1			17T	0.28	0.616
020	08101-06005	BEARING BALL	1				0.157	0.3454
030	08101-06004	BEARING BALL	1				0.065	0.143
040	K2561-11820	GEAR HIGH	1			25T	0.2	0.44
050	08221-07302	BEARING BALL	1				0.09	0.198
060	08151-06304	BEARING BALL	1				0.148	0.3256
070	37410-14320	BEARING BALL	1				0.145	0.319
080	K2561-11920	GEAR SUB	1			16-24T	0.28	0.616
090	K2561-11930	GEAR 4WD	1			12T	0.05	0.11
100	K2561-11940	CIR CLIP EXTERNAL	1				0.003	0.0066
110	K2561-11950	SHIM	2			0.5mm	0.003	0.0066
110	K2561-11960	SHIM	1			0.2mm	0.001	0.0022



PTO SHAFT

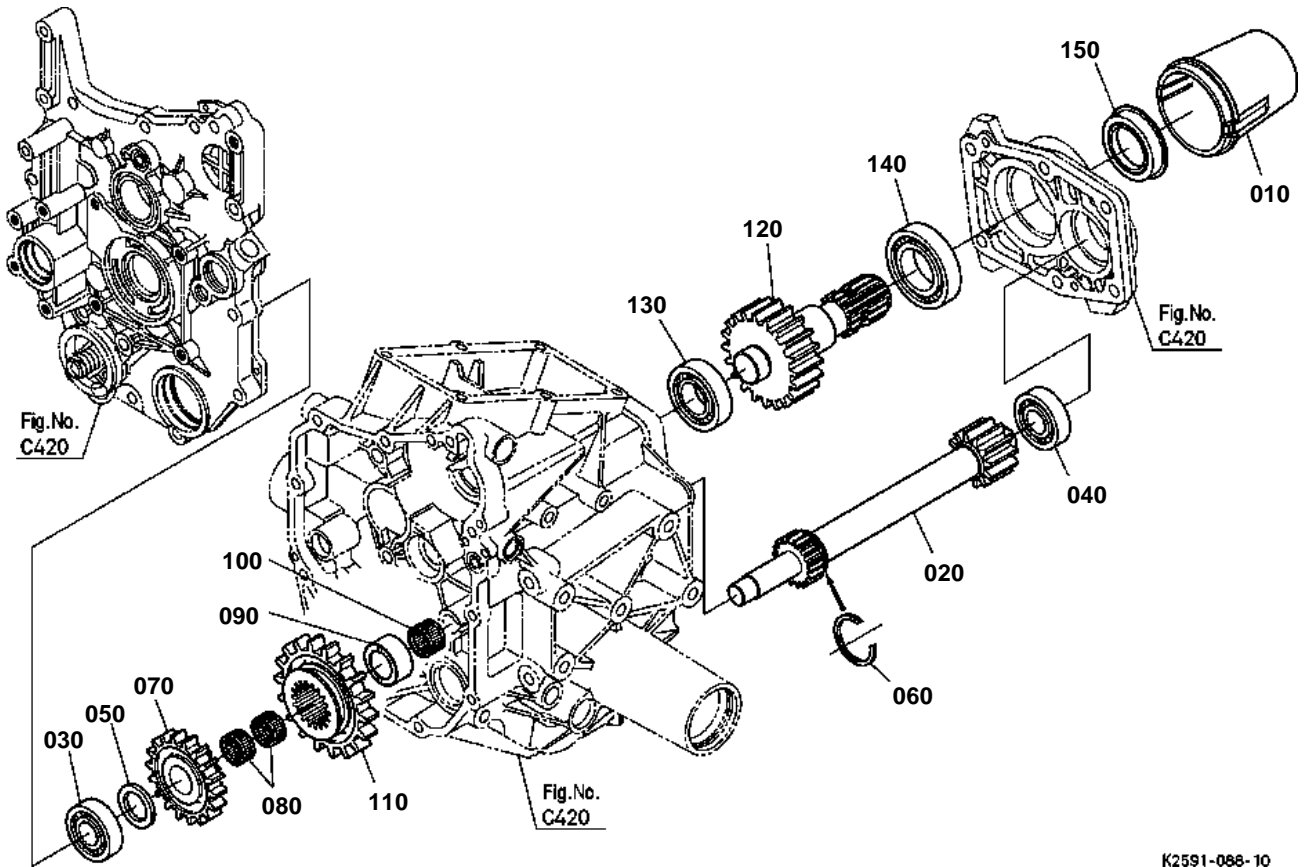



# PTO SHAFT

↔ Interchangeable; ≠ not interchangeable; ← new for old; → old for new

REF.No	Part No.	Description	Q'ty	S.No.	I/C	REMARKS	Weight (kgf)	Weight (lb)
010	37410-63112	CAP PTO SHAFT	1				0.055	0.121
020	K2561-11413	GEAR SHAFT REAR PTO	1			11T	1.2	2.64
030	08101-06303	BEARING BALL	1				0.112	0.2464
040	67955-14170	BEARING BALL	1				0.114	0.2508
050	54121-16260	WASHER	1				0.01	0.022
060	K2561-11450	CIR CLIP EXTERNAL	1				0.003	0.0066
070	K2561-11422	GEAR MID PTO	1			22T	0.43	0.946
080	08822-02413	BEARING NEEDLE	2				0.01	0.022
090	K2561-11432	COLLAR INNER RING	1				0.07	0.154
100	08822-02417	BEARING NEEDLE	1				0.015	0.033
110	K2561-11442	GEAR PTO SELECT	1			30T	0.54	1.188
120	K2561-11510	GEAR SHAFT REAR PTO	1			25T	1.71	3.762
130	67121-56770	BEARING BALL	1				0.127	0.2794
140	6C040-14730	BEARING BALL	1				0.15	0.33
150	37410-16550	SEAL OIL	1				0.03	0.066

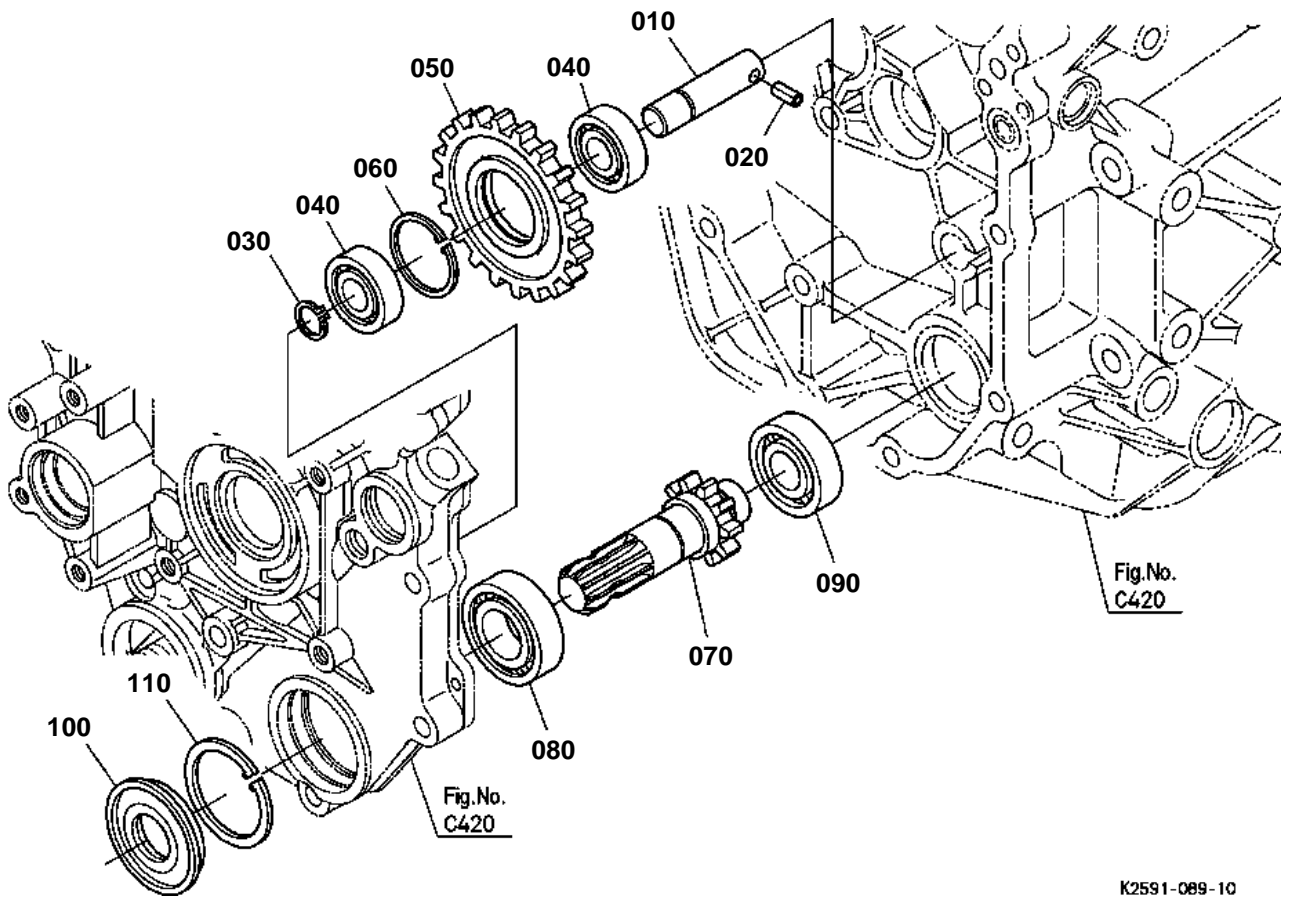

K2591-089-10

**MID PTO**

↔ Interchangeable; ≠ not interchangeable; ← new for old; → old for new

REF.No	Part No.	Description	Q'ty	S.No.	I/C	REMARKS	Weight (kgf)	Weight (lb)
010	K2561-11610	SHAFT MID PTO IDLE	1				0.12	0.264
020	05411-00616	PIN SPRING	1				0.002	0.0044
030	04612-00170	CIR CLIP EXTERNAL	1				0.001	0.0022
040	08101-06203	BEARING BALL	2				0.063	0.1386
050	K2561-11620	GEAR MID PTO IDLE	1			26T	0.43	0.946
060	04611-00400	CIR CLIP INTERNAL	1				0.005	0.011
070	K2561-11710	SHAFT GEAR	1			11T	0.46	1.012
080	08101-06205	BEARING BALL	1				0.14	0.308
090	08101-06204	BEARING BALL	1				0.102	0.2244
100	32430-25540	SEAL OIL MID PTO	1				0.04	0.088
110	04611-00520	CIR CLIP INTERNAL	1				0.009	0.0198

REAR DIFFERENTIAL

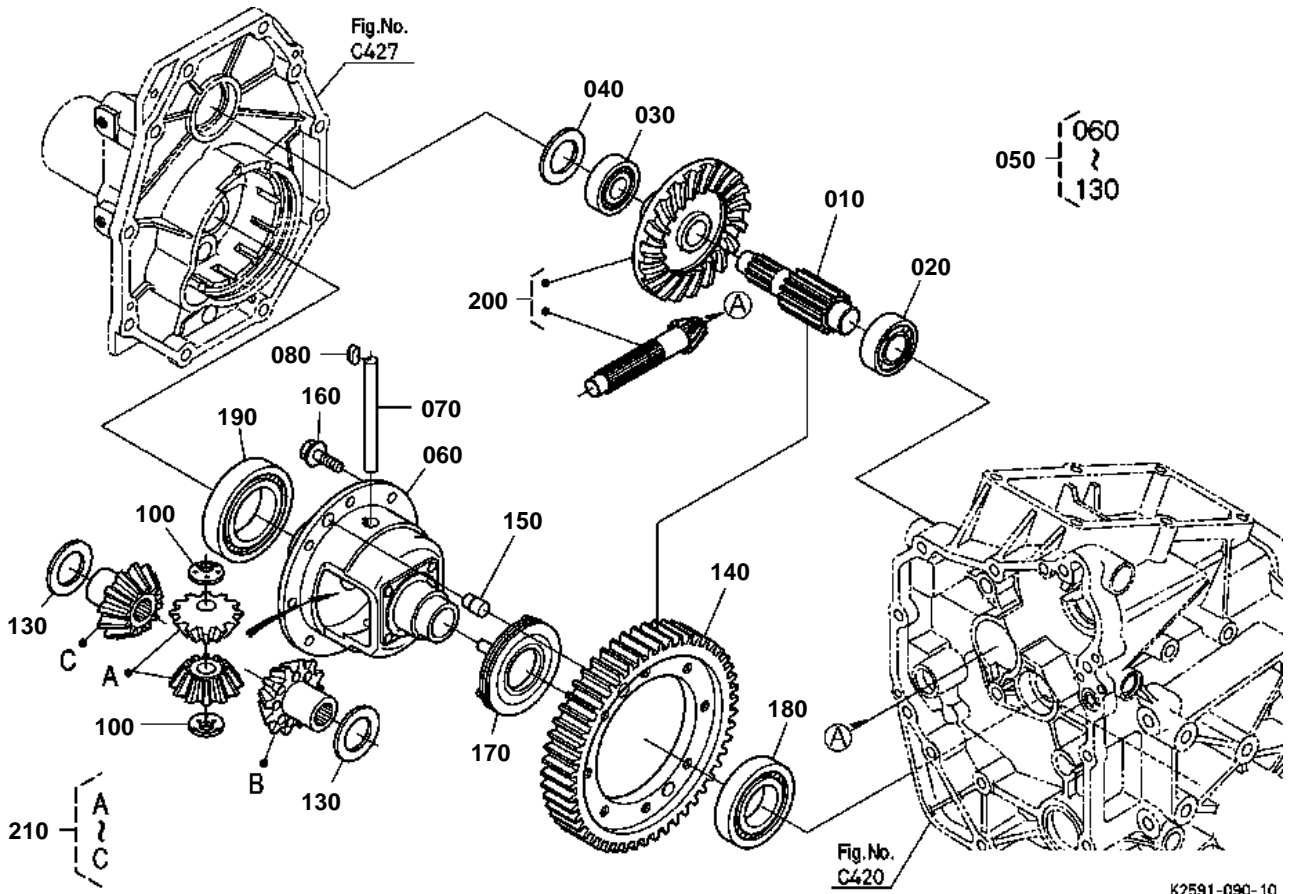

**REAR DIFFERENTIAL**

↔ Interchangeable; ≠ not interchangeable; ← new for old; → old for new

REF.No	Part No.	Description	Q'ty	S.No.	I/C	REMARKS	Weight (kgf)	Weight (lb)
010	K2561-12410	GEAR SHAFT FINAL	1			10T	0.61	1.342
020	32430-44260	BEARING ROLLER	1				0.17	0.374
030	37415-17710	BEARING BALL	1				0.15	0.33
040	K5820-38110	SHIM	1			0.6mm	0.004	0.0088
040	K5820-38120	SHIM	1			0.8mm	0.005	0.011
040	K5820-38130	SHIM	1			1.0mm	0.005	0.011
040	K5820-38140	SHIM	1			1.2mm	0.007	0.0154
040	K5820-38150	SHIM	1			1.4mm	0.008	0.0176
040	36330-28410	SHIM	1			0.3mm	0.002	0.0044
050	K2561-12510	ASSY DIFFERENTIAL	1				4.5	9.9
060	31331-26510	CASE DIFFERENTIAL	1				2.7	5.94
060	K2561-12490	CASE DIFFERENTIAL	1		↔		2.5	5.5
070	31331-26340	SHAFT DIFF.PINION	1				0.3	0.66
070	K2561-12480	SHAFT DIFF.PINION	1		↔		0.3	0.66
080	31220-26280	KEY FEATHER	1				0.005	0.011
080	K2561-12470	KEY FEATHER	1		↔		0.002	0.0044
090	99999-99999	BLANK	0				0	0
100	31351-26390	WASHER DIFF.PINION	2				0.012	0.0264
110	99999-99999	BLANK	0				0	0
120	99999-99999	BLANK	0				0	0
130	31331-26470	WASHER SIDE GEAR	2			1.5mm	0.005	0.011
130	31331-26480	WASHER SIDE GEAR	2			1.6mm	0.017	0.0374
130	31331-26490	WASHER SIDE GEAR	2			1.7mm	0.02	0.044
140	K2561-12550	GEAR FINAL	1			66T	3.71	8.162
150	37300-28170	PIN STRAIGHT	2				0.025	0.055
160	37800-43870	BOLT	8				0.026	0.0572
170	K2561-12590	SHIFTER DIFF.LOCK	1				0	0
180	08101-06208	BEARING BALL	1				0.355	0.781
190	08101-06210	BEARING BALL	1				0.45	0.99
200	K2561-90100	ASSY GEAR BEVEL	1			6-37T	1.57	3.454
210	K2561-90120	ASSY GEAR BEVEL	1			12-20T	0	0

FWD IDLE SHAFT

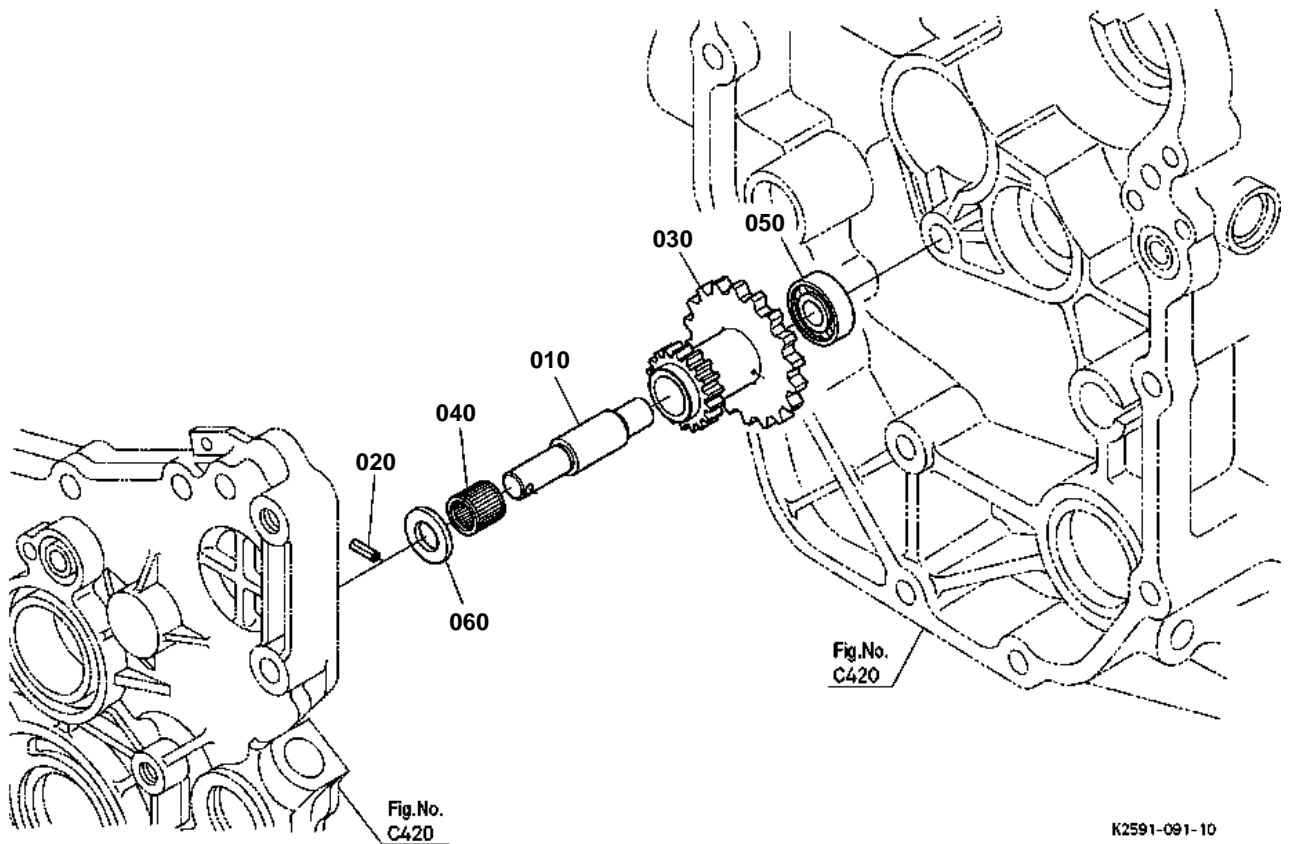

K2591-091-10



## FWD IDLE SHAFT

↔ Interchangeable; ≠ not interchangeable; ← new for old; → old for new

REF.No	Part No.	Description	Q'ty	S.No.	I/C	REMARKS	Weight (kgf)	Weight (lb)
010	K2561-12012	SHAFT FWD IDLE	1				0.12	0.264
020	05411-00416	PIN SPRING	1				0.001	0.0022
030	K2561-12020	GEAR FWD IDLE	1			13-25T	0.32	0.704
040	K2561-12040	BEARING NEEDLE	1				0.013	0.0286
050	K2561-12050	BEARING BALL	1				0.04	0.088
060	54121-16270	WASHER	1				0.002	0.0044



GP IDLE SHAFT

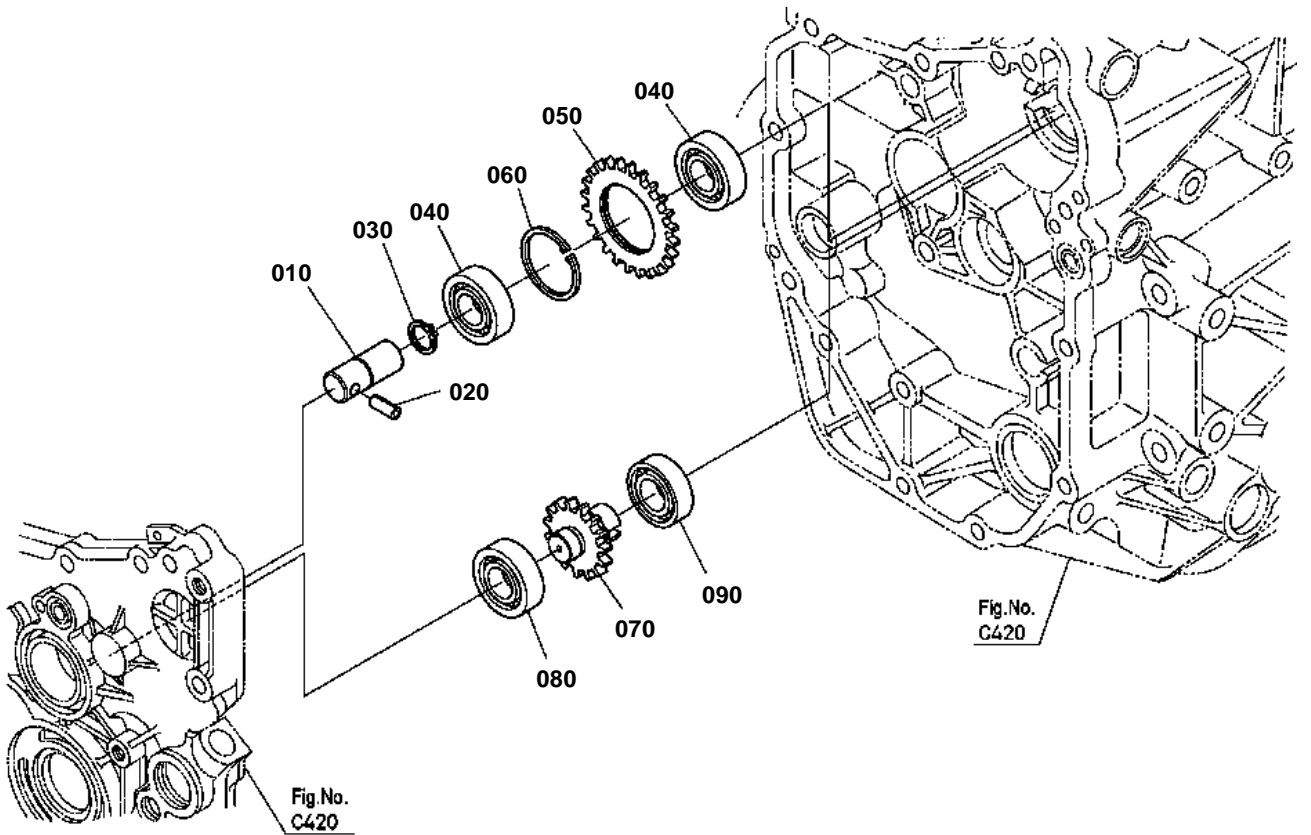

K2591-092-10



## GP IDLE SHAFT

↔ Interchangeable; ≠ not interchangeable; ← new for old; → old for new

REF.No	Part No.	Description	Q'ty	S.No.	I/C	REMARKS	Weight (kgf)	Weight (lb)
010	K2561-12210	SHAFT GP IDLE	1				0.001	0.0022
020	05411-00616	PIN SPRING	1				0.002	0.0044
030	04612-00170	CIR CLIP EXTERNAL	1				0.001	0.0022
040	08101-06203	BEARING BALL	2				0.063	0.1386
050	K2561-12220	GEAR GP IDLE	1			29T	0.12	0.264
060	04611-00400	CIR CLIP INTERNAL	1				0.005	0.011
070	K2561-12310	GEAR SHAFT GP	1			19T	0.15	0.33
080	08101-06203	BEARING BALL	1				0.063	0.1386
090	08101-06004	BEARING BALL	1				0.065	0.143

FRONT WHEEL PROPELLER SHAFT

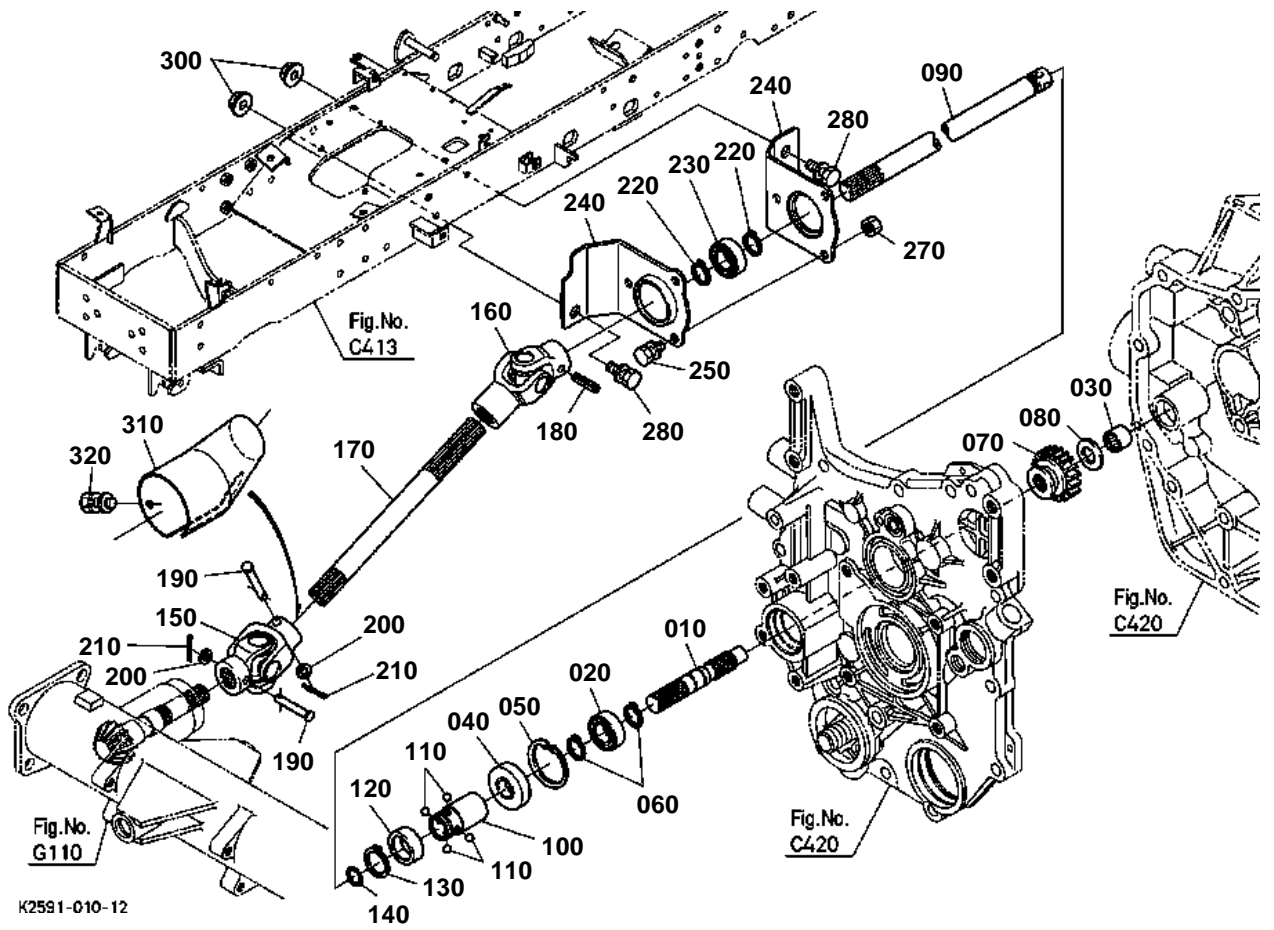

K25S1-010-12

# OLD PARTS

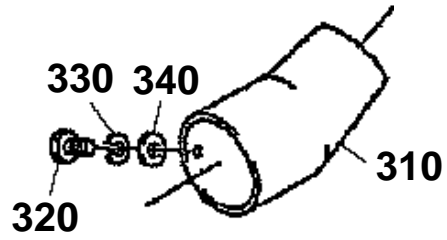
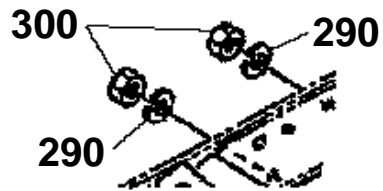
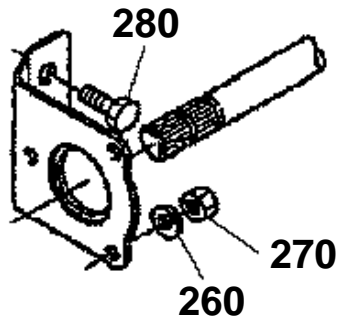

K2591-807-11



**FRONT WHEEL PROPELLER SHAFT**

↔ Interchangeable; ≠ not interchangeable; ← new for old; → old for new

REF.No	Part No.	Description	Q'ty	S.No.	I/C	REMARKS	Weight (kgf)	Weight (lb)
010	K2561-12110	SHAFT 4WD	1				0.26	0.572
020	08101-06004	BEARING BALL	1				0.065	0.143
030	K2561-12120	BEARING NEEDLE	1				0.02	0.044
040	09500-20428	SEAL OIL	1				0.012	0.0264
050	04611-00420	CIR CLIP INTERNAL	1				0.006	0.0132
060	04612-00200	CIR CLIP EXTERNAL	2				0.001	0.0022
070	K2561-12130	GEAR FWD SELECT	1			19T	0.2	0.44
080	67910-12330	COLLAR	1				0.006	0.0132
090	K2561-14310	SHAFT FWD DRIVE	1				1.47	3.234
100	K2561-14320	COUPLING FWD	1				0.15	0.33
110	07715-01605	BALL	4				0.003	0.0066
120	K2561-14330	COLLAR COUPLING	1				0.05	0.11
130	04612-00280	CIR CLIP EXTERNAL	1				0.003	0.0066
140	04817-00160	O RING	1				0.001	0.0022
150	K2561-16810	ASSY JOINT UNIVERSAL	1				0.63	1.386
160	K2561-16820	ASSY JOINT UNIVERSAL	1				0.73	1.606
170	K2561-16830	SHAFT DRIVE FRONT	1				0.69	1.518
180	05411-00650	PIN SPRING	1				0.006	0.0132
190	K2561-16780	PIN JOINT	2				0.01	0.022
200	04013-60060	WASHER PLAIN	2				0.001	0.0022
210	K2561-16790	PIN SPLIT	2				0.002	0.0044
220	15875-24320	RING SNAP	2				0.003	0.0066
230	08141-06304	BEARING BALL	1				0.142	0.3124
240	K2561-16890	HOLDER BEARING	2				0.256	0.5632
250	01123-50820	BOLT	3				0.011	0.0242
270	02114-50080	NUT	3				0.005	0.011
280	01133-51230	BOLT	2				0.04	0.088
300	02174-50120	NUT	2				0.01	0.022
310	K2511-16850	COVER JOINT	1				0	0
320	01025-50612	BOLT	1				0.005	0.011

RANGE GEAR SHIFT FORK

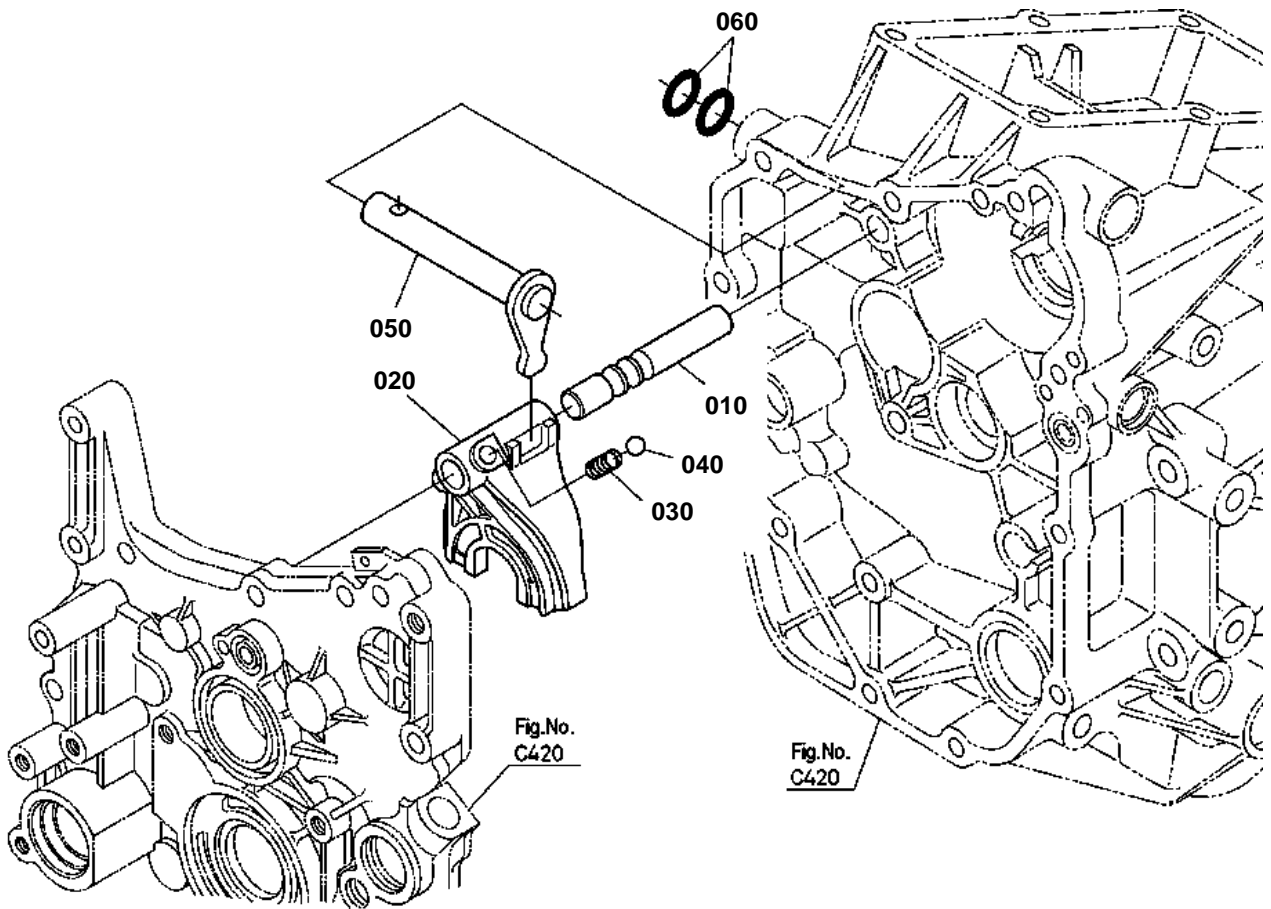

K2591-093-10



## RANGE GEAR SHIFT FORK

↔ Interchangeable; ≠ not interchangeable; ← new for old; → old for new

REF.No	Part No.	Description	Q'ty	S.No.	I/C	REMARKS	Weight (kgf)	Weight (lb)
010	K2561-13010	ROD FORK	1				0.11	0.242
020	K2561-13022	FORK RANGE SHIFT	1				0.12	0.264
030	62061-18260	SPRING STOPPER	1				0.002	0.0044
040	07715-01605	BALL	1				0.003	0.0066
050	K2561-13032	ARM RANGE SHIFT	1				0.19	0.418
060	04817-00160	O RING	2				0.001	0.0022

PTO GEAR SHIFT FORK

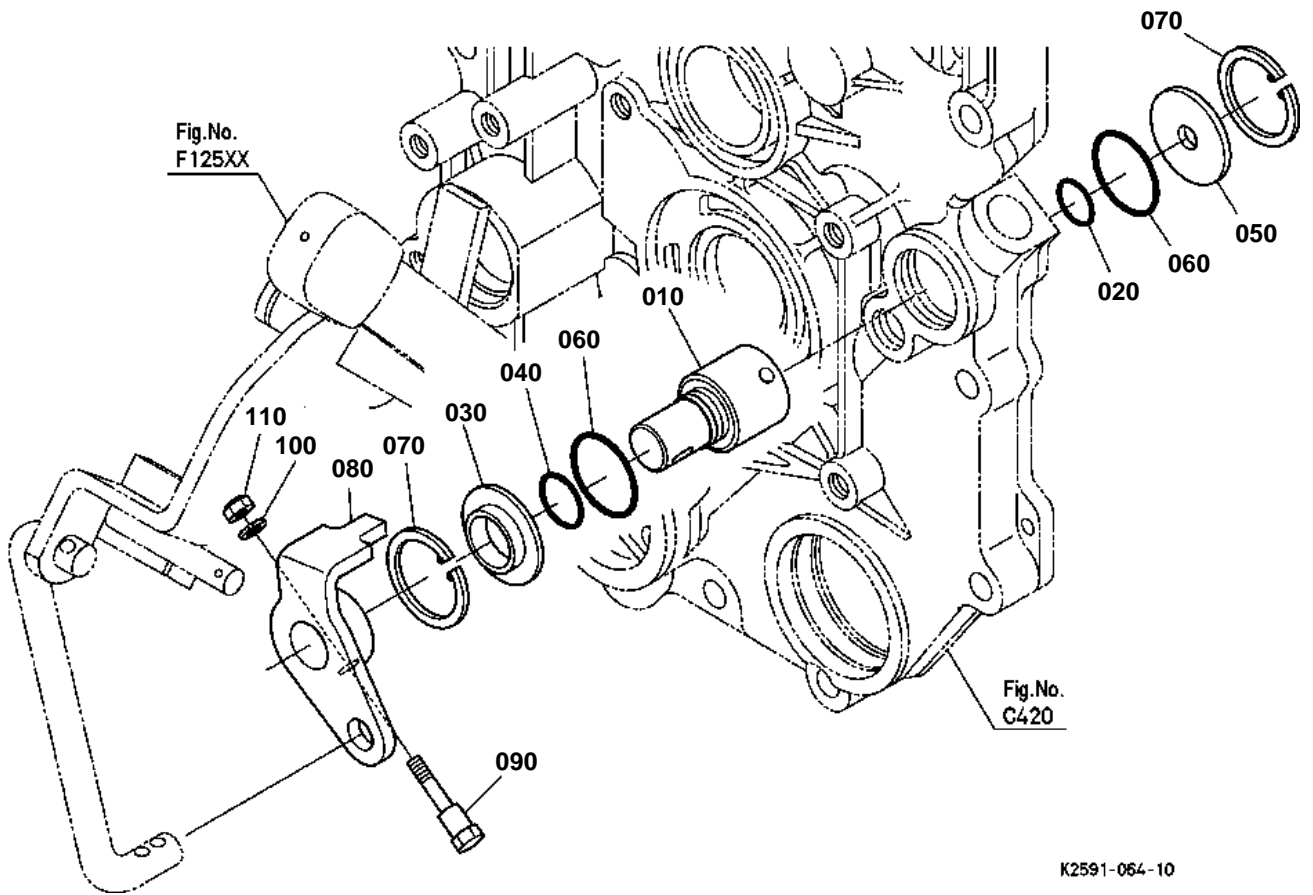

K2591-064-10





## PTO GEAR SHIFT FORK

↔ Interchangeable; ≠ not interchangeable; ← new for old; → old for new

REF.No	Part No.	Description	Q'ty	S.No.	I/C	REMARKS	Weight (kgf)	Weight (lb)
010	K2561-13410	SHAFT PTO CLUTCHONOF	1				0.11	0.242
020	04811-10100	O RING	1				0.001	0.0022
030	K2561-13420	SLEEVE PTO CLUTCH	1				0.012	0.0264
040	04816-05120	O RING	1				0.002	0.0044
050	K2561-13430	COLLOR PTO CLUTCH	1				0.012	0.0264
060	04811-10250	O RING	2				0.001	0.0022
070	04611-00300	CIR CLIP INTERNAL	2				0.004	0.0088
080	K2561-13450	ARM PTO CLUTCH	1				0.1	0.22
090	K2561-42420	BOLT HST TRUNNION	1				0.017	0.0374
100	04512-60060	WASHER SPRING	1				0.001	0.0022
110	02552-50060	NUT LOCK	1				0.002	0.0044

PTO GEAR SHIFT ARM

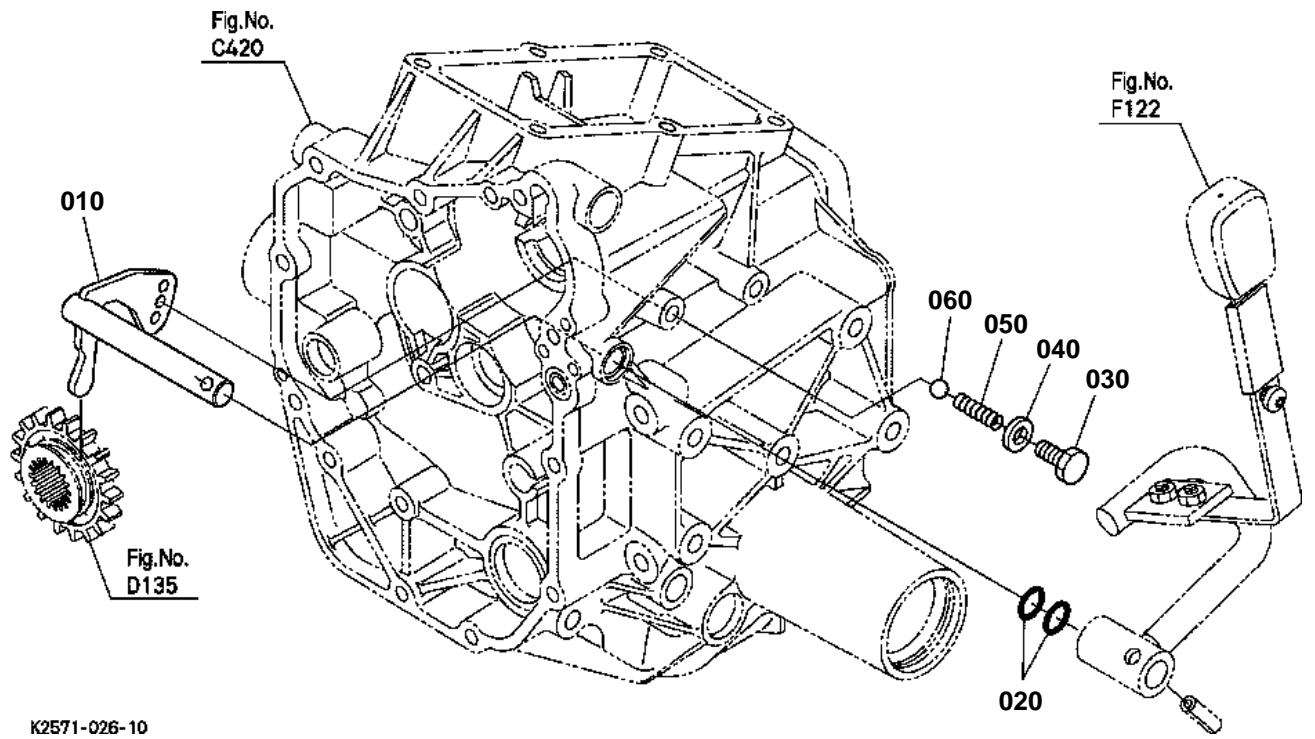

K2571-026-10



## PTO GEAR SHIFT ARM

↔ Interchangeable; ≠ not interchangeable; ← new for old; → old for new

REF.No	Part No.	Description	Q'ty	S.No.	I/C	REMARKS	Weight (kgf)	Weight (lb)
010	K2561-13110	ARM PTO SELECT	1				0.28	0.616
020	04817-00160	O RING	2				0.001	0.0022
030	K2561-13122	BOLT PTO SELECT	1				0.23	0.506
040	04717-01000	WASHER WITH RUBBER	1				0.001	0.0022
050	62061-18260	SPRING STOPPER	1				0.002	0.0044
060	07715-01605	BALL	1				0.003	0.0066

DIFFERENTIAL LOCK SHIFT FORK

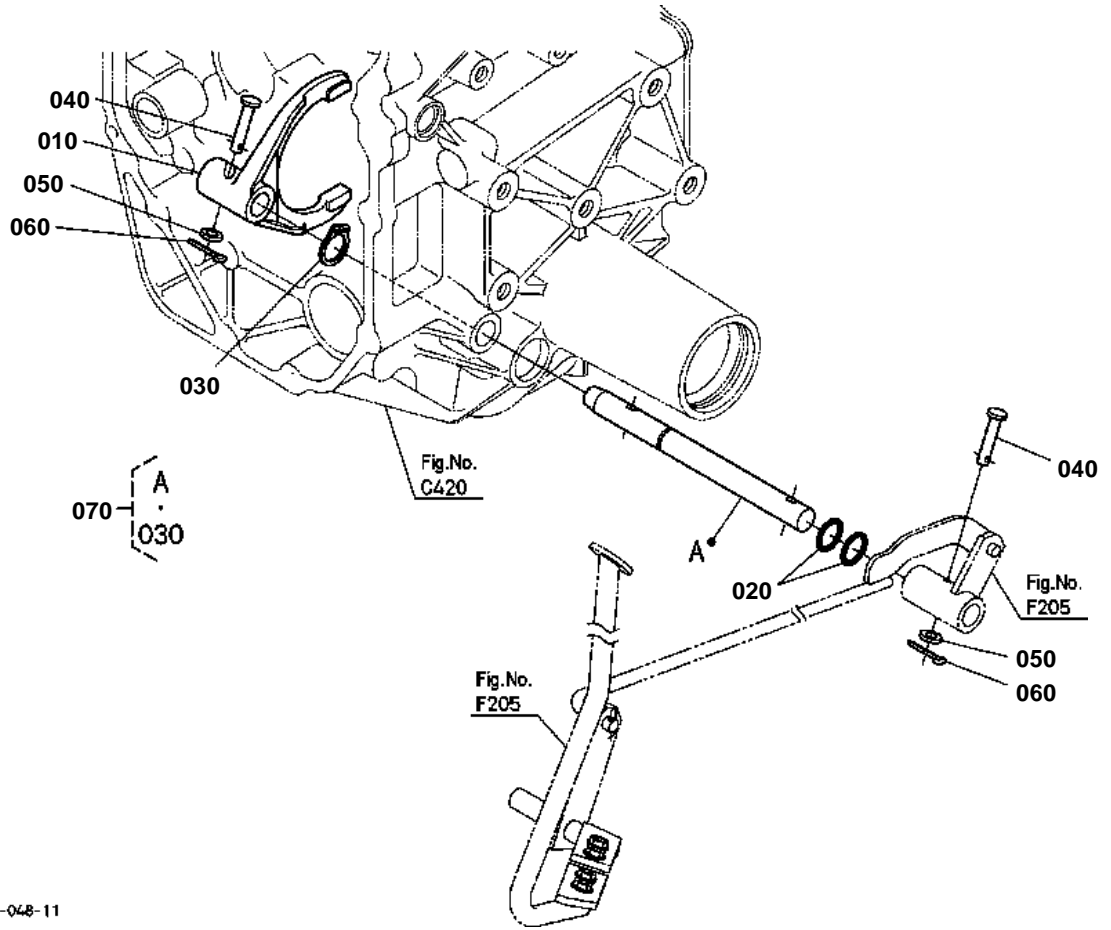

K2591-048-11



## DIFFERENTIAL LOCK SHIFT FORK

↔ Interchangeable; ≠ not interchangeable; ← new for old; → old for new

REF.No	Part No.	Description	Q'ty	S.No.	I/C	REMARKS	Weight (kgf)	Weight (lb)
010	K2561-13313	FORK DIFF.LOCK SHIFT	1				0.28	0.616
020	04817-00160	O RING	2				0.001	0.0022
030	14541-24320	CIR CLIP IDLE GEAR	1				0.002	0.0044
040	31351-26620	PIN JOINT	2				0.008	0.0176
050	04013-60060	WASHER PLAIN	2				0.001	0.0022
060	05511-50212	PIN SPLIT	2				0.001	0.0022
070	K2561-13390	KIT SHAFT DIFF.LOCK	1				0.3	0.66

REAR AXLE

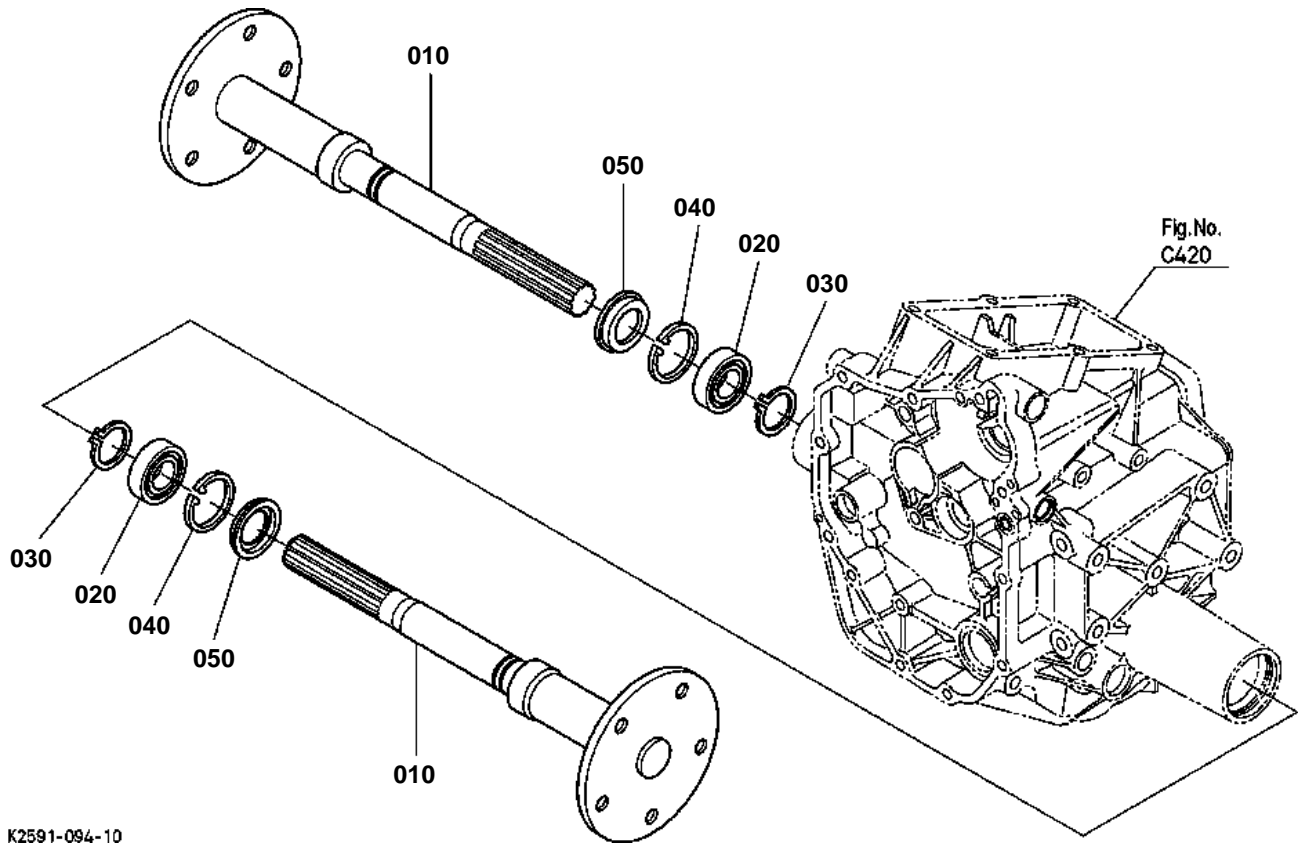

K2591-094-10



## REAR AXLE

↔ Interchangeable; ≠ not interchangeable; ← new for old; → old for new

REF.No	Part No.	Description	Q'ty	S.No.	I/C	REMARKS	Weight (kgf)	Weight (lb)
010	K2561-12613	AXLE REAR	2				4.18	9.196
020	08101-06007	BEARING BALL	2				0.16	0.352
030	04612-00350	CIR CLIP EXTERNAL	2				0.01	0.022
040	04611-00620	CIR CLIP INTERNAL	2				0.011	0.0242
050	09500-00003	SEAL OIL	2				0.067	0.1474

BRAKE

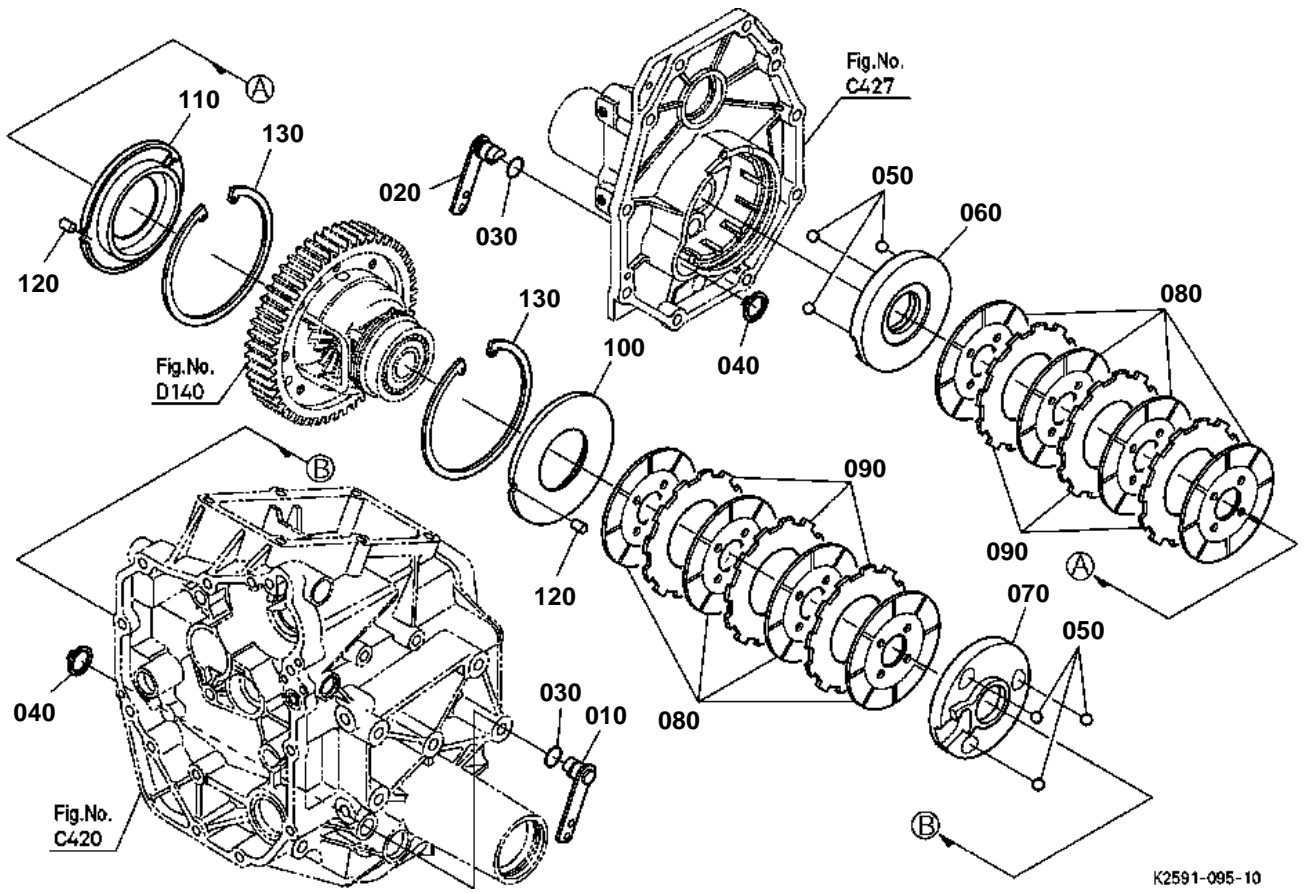



**BRAKE**

↔ Interchangeable; ≠ not interchangeable; ← new for old; → old for new

REF.No	Part No.	Description	Q'ty	S.No.	I/C	REMARKS	Weight (kgf)	Weight (lb)
010	K2561-13512	LEVER CAM LH	1				0.375	0.825
020	K2561-13522	LEVER CAM RH	1				0.385	0.847
030	04816-00240	O RING	2				0.003	0.0066
040	04612-00300	CIR CLIP EXTERNAL	2				0.003	0.0066
050	07715-00805	BALL	6				0.016	0.0352
060	K2561-13530	ACTUATOR LH	1				0.63	1.386
070	K2561-13540	ACTUATOR RH	1				0.62	1.364
080	6C090-22350	DISK BRAKE	8				0.18	0.396
090	6C140-22340	PLATE FRICTION	6				0.12	0.264
100	K2561-13550	HOLDER BEARING LH	1				0.59	1.298
110	K2561-13560	HOLDER BEARING RH	1				0.81	1.782
120	K2561-13580	PIN	2				0.006	0.0132
130	K2561-13570	CIR-CLIP INTERNAL	2				0.04	0.088

NEUTRAL HOLDER LINK

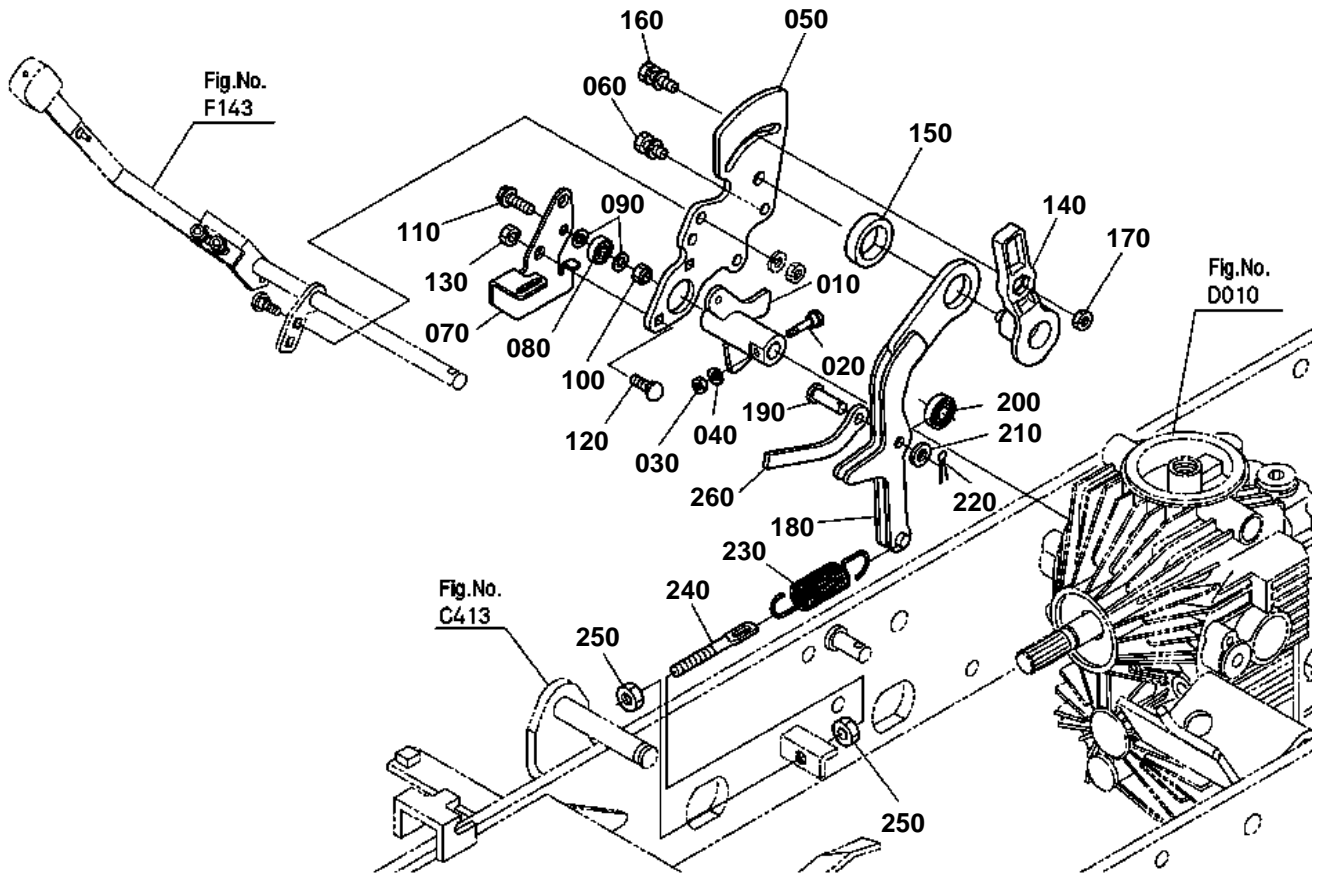

K2591-067-10

# OLD PARTS

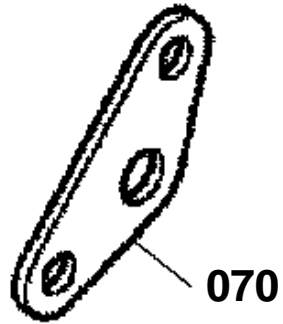

K2591-836-11



# NEUTRAL HOLDER LINK

↔ Interchangeable; ≠ not interchangeable; ← new for old; → old for new

REF.No	Part No.	Description	Q'ty	S.No.	I/C	REMARKS	Weight (kgf)	Weight (lb)
010	K2571-42410	ARM HST TRUNNION	1				0.36	0.792
020	K2561-42420	BOLT HST TRUNNION	1				0.017	0.0374
030	02014-50060	NUT	1				0.002	0.0044
040	04512-60060	WASHER SPRING	1				0.001	0.0022
050	K2591-42452	PLATE HST NEUTRAL	1				0	0
060	01123-50825	BOLT	2				0.013	0.0286
070	K2591-42443	PLATE HST TRUNNION	1				0	0
080	K2561-42530	BEARING BALL	1				0.012	0.0264
090	04012-50080	WASHER PLAIN	2				0.001	0.0022
100	02552-50080	NUT LOCK	1				0.005	0.011
110	01754-50825	BOLT FLANGE	1				0.01	0.022
120	K1122-91320	BOLT SHORT SQU.NECK	2				0.01	0.022
130	02751-50080	NUT FLANGE	2				0.006	0.0132
140	K2561-42470	LEVER NEUTRAL	1				0.14	0.308
150	K2561-42480	COLLAR	1				0.045	0.099
160	01125-50825	BOLT	1				0.018	0.0396
170	02054-50080	NUT	1				0.005	0.011
180	K2561-42513	ARM HST NEUTRAL	1				0.26	0.572
190	K2561-61460	PIN JOINT	1				0.012	0.0264
200	K2561-42530	BEARING BALL	1				0.012	0.0264
210	04013-60080	WASHER PLAIN	1				0.002	0.0044
220	05511-50218	PIN SPLIT	1				0.001	0.0022
230	K2561-42563	SPRING	1				0.13	0.286
240	K2561-42570	ROD ADJUST	1				0.029	0.0638
250	02114-50080	NUT	2				0.005	0.011
260	K2591-42590	ROD SWITCH	1				0	0

SPEED CONTROL PEDAL

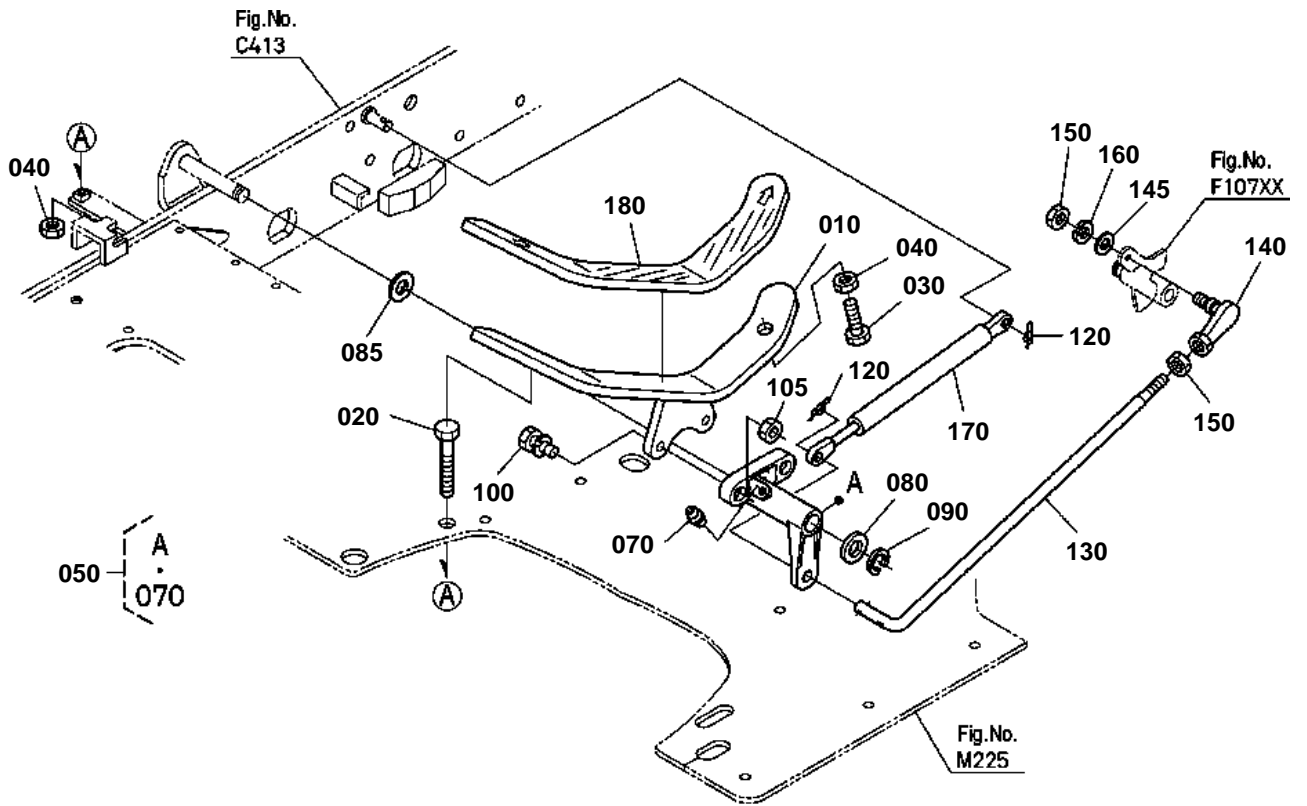

K2591-068-10

# OLD PARTS

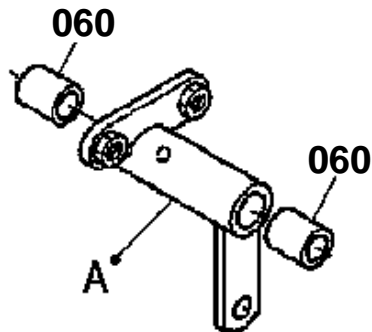
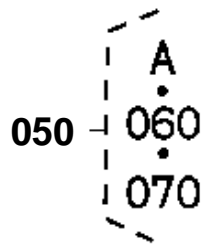
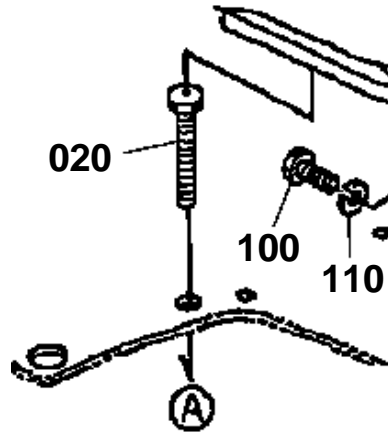

K2591-825-11



## SPEED CONTROL PEDAL

↔ Interchangeable; ≠ not interchangeable; ← new for old; → old for new

REF.No	Part No.	Description	Q'ty	S.No.	I/C	REMARKS	Weight (kgf)	Weight (lb)
010	K2561-42010	PEDAL HST	1				1.12	2.464
020	01153-50890	BOLT	1				0.033	0.0726
030	01153-50825	BOLT	1				0.012	0.0264
040	02114-50080	NUT	2				0.005	0.011
050	K2511-42100	LINK PEDAL HST	1				0.12	0.264
070	67211-42940	NIPPLE GREASE	1				0.001	0.0022
080	K2561-42130	WASHER PLAIN	1				0.004	0.0088
085	K2571-42120	WASHER PLAIN	1				0	0
090	75599-41522	CIR-CLIP EXTERNAL	1				0.001	0.0022
100	01123-50825	BOLT	2				0.013	0.0286
105	02054-50080	NUT	2				0.005	0.011
120	K1211-91130	RUE RING COTTER	2				0.01	0.022
130	K2561-42170	ROD SPEED CHANGE	1				0.2	0.44
140	K1122-42080	ROD END	1				0.03	0.066
145	75599-32112	WASHER PLAIN	1				0.001	0.0022
150	75599-31022	NUT	2				0.015	0.033
160	04512-60080	WASHER SPRING	1				0.002	0.0044
170	K2561-42150	DAMPER HST	1				0.17	0.374
180	K2561-42310	COVER HST PEDAL	1				0.26	0.572

RANGE GEAR SHIFT LEVER

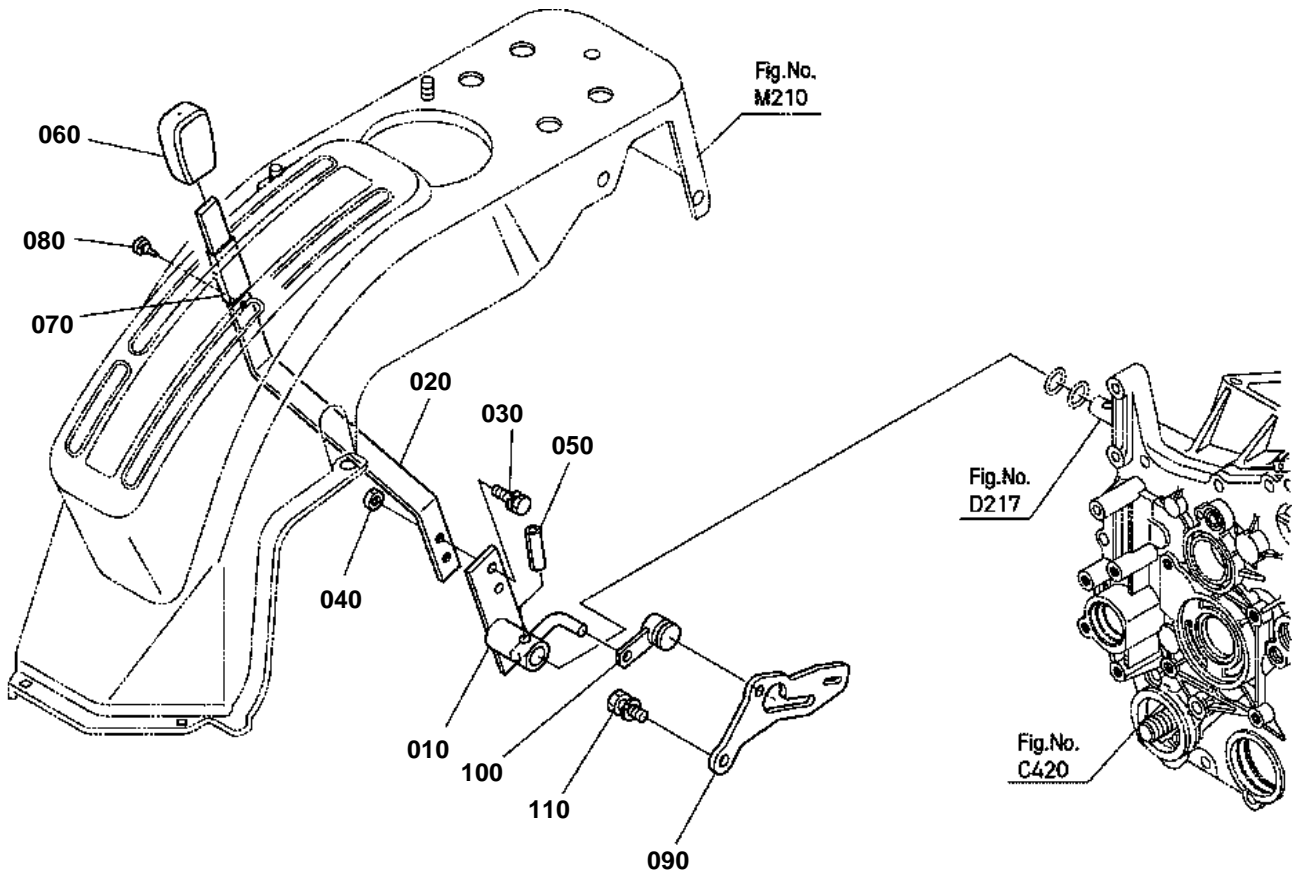

K2591-013-11





## RANGE GEAR SHIFT LEVER

↔ Interchangeable; ≠ not interchangeable; ← new for old; → old for new

REF.No	Part No.	Description	Q'ty	S.No.	I/C	REMARKS	Weight (kgf)	Weight (lb)
010	K2561-42970	LEVER SUB SELECT	1				0.39	0.858
020	K2571-42920	LEVER SUB UPPER	1				0.17	0.374
030	01123-50820	BOLT	2				0.011	0.0242
040	02114-50080	NUT	2				0.005	0.011
050	05411-00836	PIN SPRING	1				0.008	0.0176
060	K2571-42740	GRIP LEVER SUB	1				0	0
070	K2571-42632	CUSHION	1				0	0
080	K2561-54370	CUSHION	1				0.001	0.0022
090	K2561-42720	STAY SWITCH NEUTRAL	1				0.21	0.462
100	K2561-42730	ROD SWITCH	1				0.11	0.242
110	01123-50820	BOLT	2				0.011	0.0242

FRONT WHEEL DRIVE LEVER

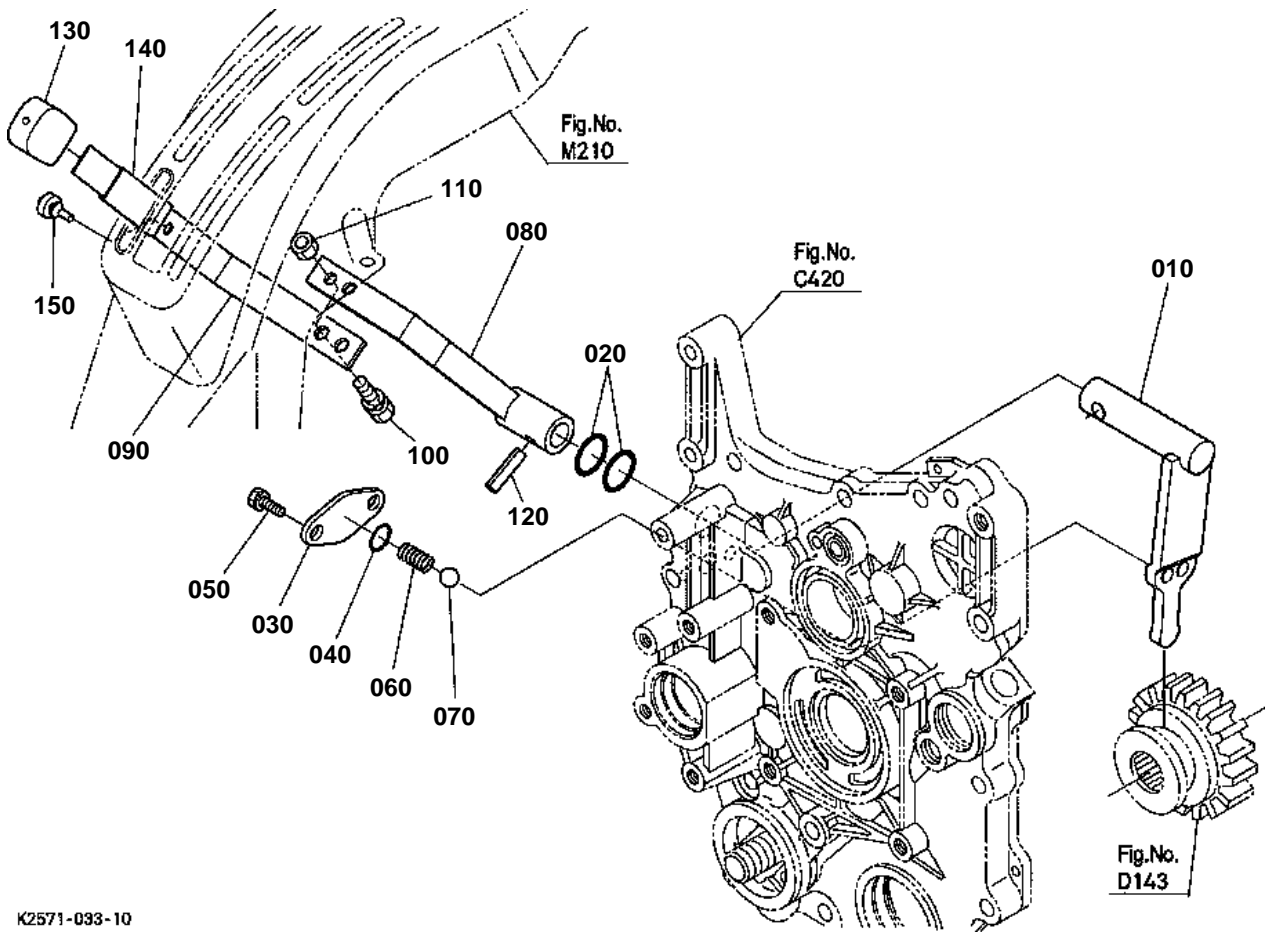

K2571-033-10

# OLD PARTS

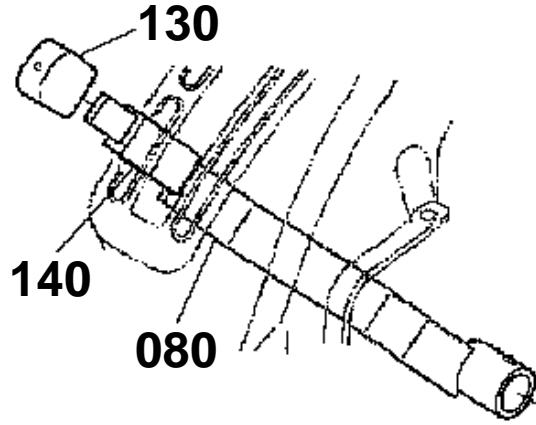

K2591-826-11



## FRONT WHEEL DRIVE LEVER

↔ Interchangeable; ≠ not interchangeable; ← new for old; → old for new

REF.No	Part No.	Description	Q'ty	S.No.	I/C	REMARKS	Weight (kgf)	Weight (lb)
010	K2561-13210	ARM 4WD SHIFT	1				0.2	0.44
020	04817-00160	O RING	2				0.001	0.0022
030	K2561-13220	PLATE FWD SELECT	1				0.008	0.0176
040	04817-00090	O RING	1				0.001	0.0022
050	01023-50614	BOLT	2				0.005	0.011
060	62061-18260	SPRING STOPPER	1				0.002	0.0044
070	07715-01605	BALL	1				0.003	0.0066
080	K2571-42750	LEVER 4WD SELECT	1				0	0
090	K2571-42950	LEVER FWD SELECT UP.	1				0.11	0.242
100	01123-50820	BOLT	2				0.011	0.0242
110	02114-50080	NUT	2				0.005	0.011
120	05411-00836	PIN SPRING	1				0.008	0.0176
130	K2571-42780	GRIP LEVER 4WD	1				0	0
140	K2571-42632	CUSHION	1				0	0
150	K2561-54370	CUSHION	1				0.001	0.0022

PTO SELECT LEVER

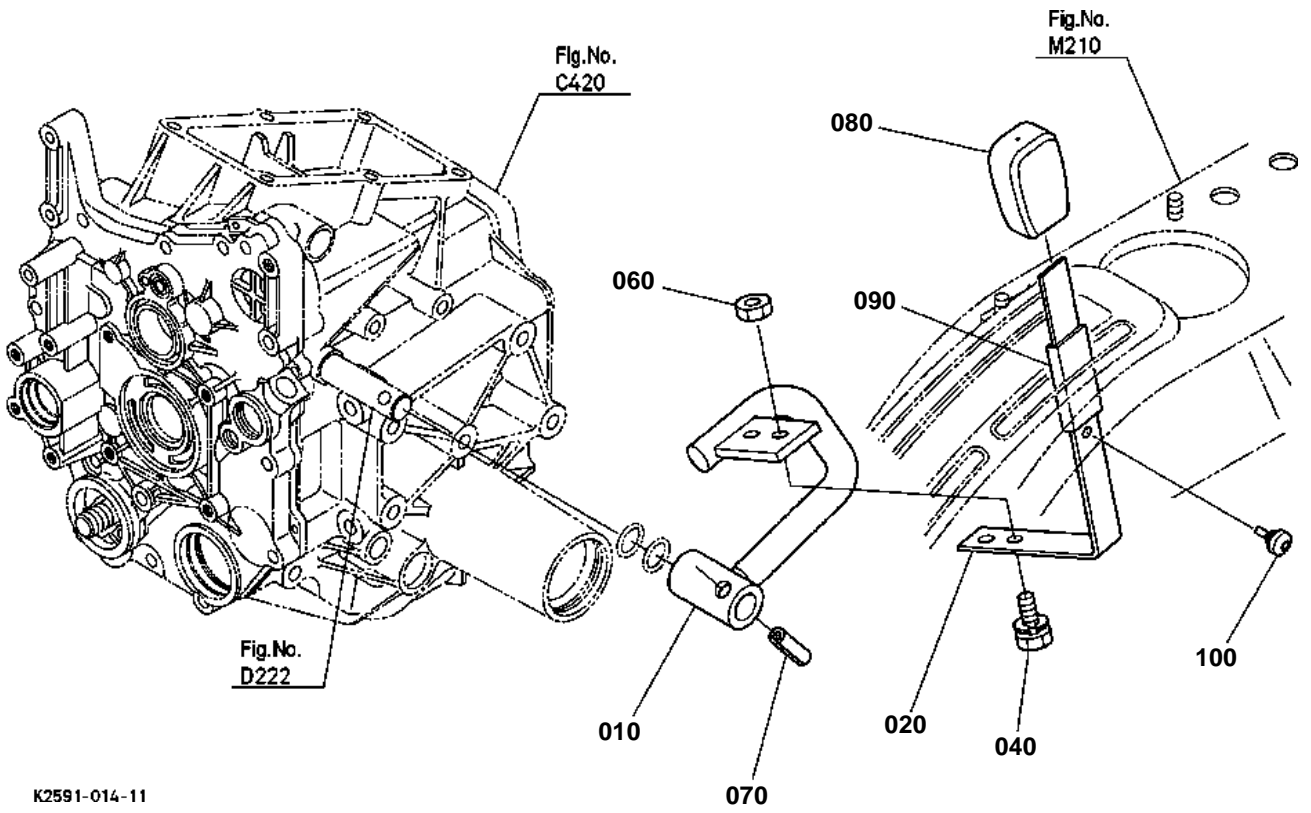

K2591-014-11

# OLD PARTS

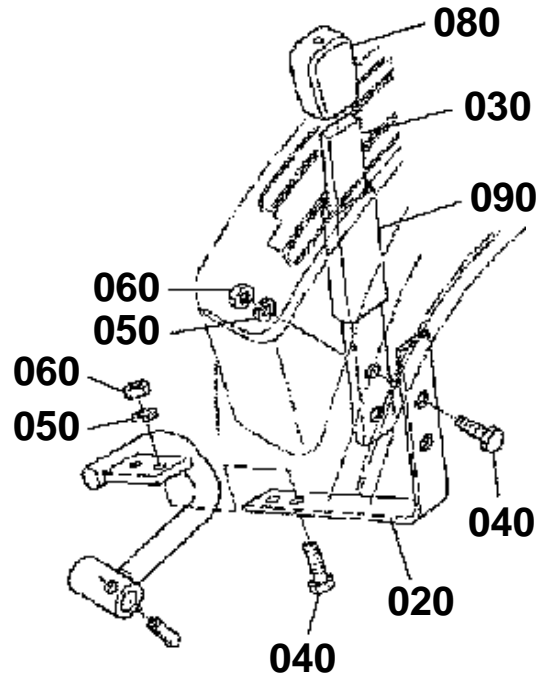

K2591-827-11



## PTO SELECT LEVER

↔ Interchangeable; ≠ not interchangeable; ← new for old; → old for new

REF.No	Part No.	Description	Q'ty	S.No.	I/C	REMARKS	Weight (kgf)	Weight (lb)
010	K2561-42962	LEVER PTO SELECT	1				0.96	2.112
020	K2571-42910	LEVER PTO SELECT UP.	1				0.12	0.264
040	01123-50820	BOLT	2				0.011	0.0242
060	02114-50080	NUT	2				0.005	0.011
070	05411-00836	PIN SPRING	1				0.008	0.0176
080	K2571-42620	GRIP LEVER PTO	1				0	0
090	K2571-42632	CUSHION	1				0	0
100	K2561-54370	CUSHION	1				0.001	0.0022

PTO GEAR SHIFT LEVER

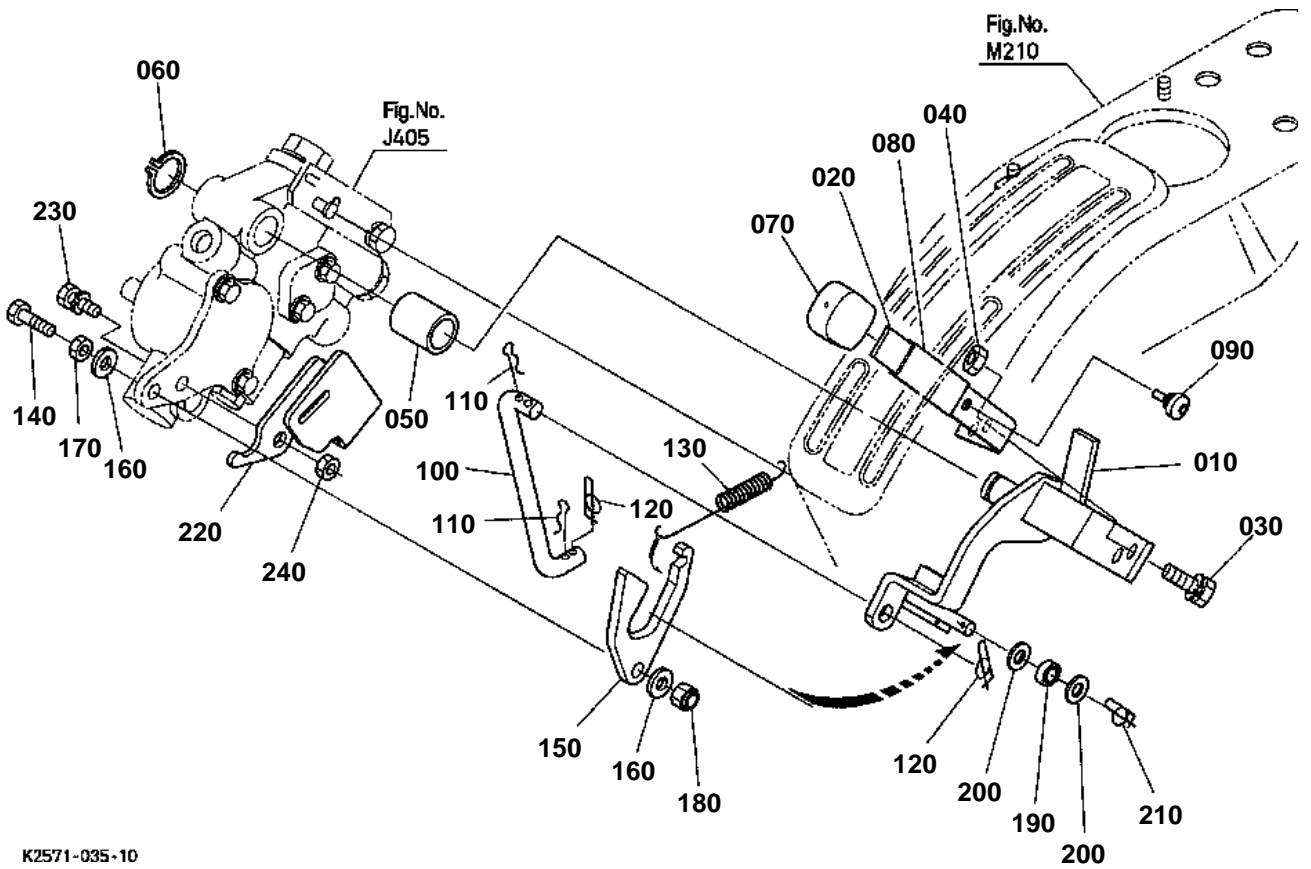

K2571-035-10





## PTO GEAR SHIFT LEVER

↔ Interchangeable; ≠ not interchangeable; ← new for old; → old for new

REF.No	Part No.	Description	Q'ty	S.No.	I/C	REMARKS	Weight (kgf)	Weight (lb)
010	K2571-42650	LEVER PTO CLUTCH	1				0.46	1.012
020	K2571-42930	LEVER PTO CLUTCH UP.	1				0.07	0.154
030	01123-50820	BOLT	2				0.011	0.0242
040	02114-50080	NUT	2				0.005	0.011
050	K2561-42140	BUSHING DU	1				0.05	0.11
060	04612-00160	CIR CLIP EXTERNAL	1				0.001	0.0022
070	K2571-42660	GRIP LEVER CLUTCH	1				0	0
080	K2571-42632	CUSHION	1				0	0
090	K2561-54370	CUSHION	1				0.001	0.0022
100	K2561-42670	ROD PTO CLUTCH	1				0.11	0.242
110	75599-56004	PIN SNAP	2				0.01	0.022
120	K1211-91130	RUE RING COTTER	2				0.01	0.022
130	K2561-42640	SPRING POSITION	1				0.017	0.0374
140	01155-50830	BOLT	1				0.01	0.022
150	K2571-42890	CAM PTO CLUCH	1				0.085	0.187
160	04013-60080	WASHER PLAIN	2				0.002	0.0044
170	02114-50080	NUT	1				0.005	0.011
180	K5112-72840	NUT LOCK	1				0.005	0.011
190	K2561-42530	BEARING BALL	1				0.012	0.0264
200	04015-60080	WASHER PLAIN	2				0.01	0.022
210	K1211-91120	RUE RING COTTER	1				0.001	0.0022
220	K2511-42990	STAY	1				0.085	0.187
230	01123-50820	BOLT	1				0.011	0.0242
240	02114-50080	NUT	1				0.005	0.011

HYDRAULIC CONTROL LEVER

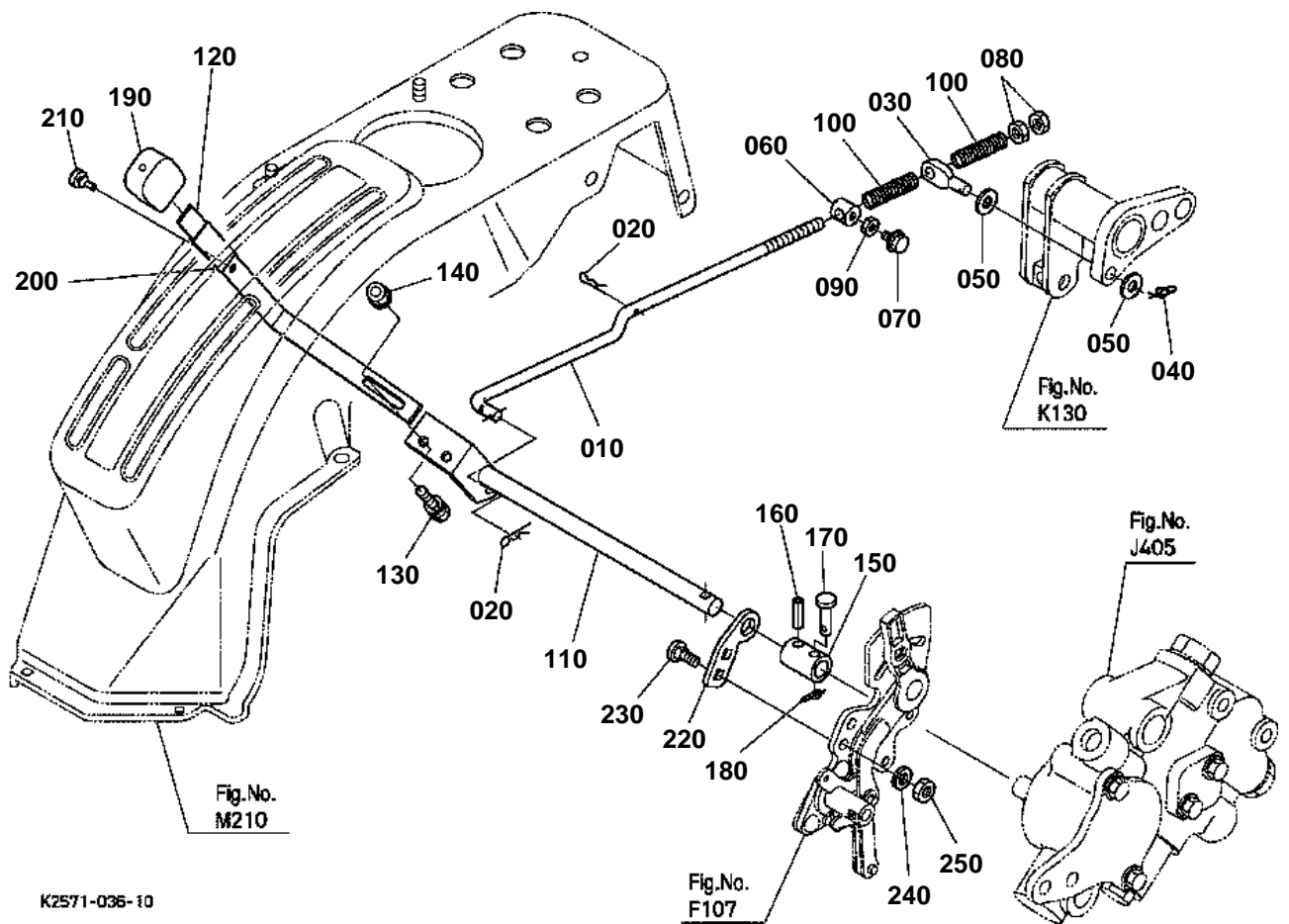

K2571-036-10

# OLD PARTS

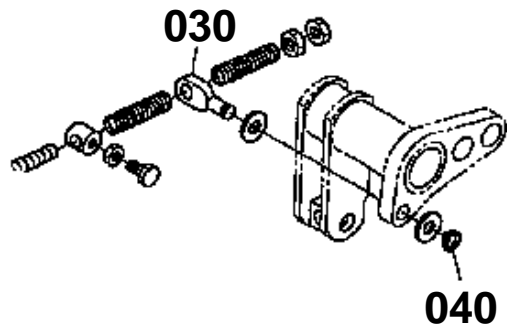
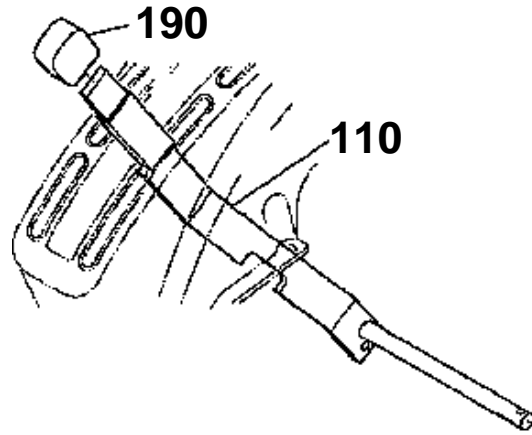

K2591-841-10



# HYDRAULIC CONTROL LEVER

↔ Interchangeable; ≠ not interchangeable; ← new for old; → old for new

REF.No	Part No.	Description	Q'ty	S.No.	I/C	REMARKS	Weight (kgf)	Weight (lb)
010	K2561-36360	ROD FEED BACK	1				0.12	0.264
020	75599-56003	PIN SNAP	2				0.001	0.0022
030	K2561-36370	PIN FEEDBACK	1				0.04	0.088
030	K2571-36370	PIN FEED BACK	1		←	OLD PARTS NEW PARTS	0	0
040	04613-50090	CIR CLIP EXTERNAL	1			OLD PARTS	0.001	0.0022
040	K1211-91140	RUE RING COTTER	1		≠	NEW PARTS	0.002	0.0044
050	04011-50120	WASHER PLAIN	2				0.005	0.011
060	K2561-36380	BRACKET FEEDBACK	1				0.021	0.0462
070	01754-50612	BOLT FLANGE	1				0.005	0.011
080	02054-50080	NUT	2				0.005	0.011
090	02014-50060	NUT	1				0.002	0.0044
100	K2561-36390	SPRING	2				0.015	0.033
110	K2571-42810	LEVER HYD.CONTROL	1				0	0
120	K2571-42940	LEVER HYD.CON.UPPER	1				0	0
130	01123-50820	BOLT	2				0.011	0.0242
140	02751-50080	NUT FLANGE	2				0.006	0.0132
150	K2561-42840	BOSS HYD LEVER	1				0	0
160	05411-00836	PIN SPRING	1				0.008	0.0176
170	05122-50830	PIN JOINT	1				0.014	0.0308
180	K1211-91120	RUE RING COTTER	1				0.001	0.0022
190	K2571-42820	GRIP HYD LEVER	1				0	0
200	K2571-42632	CUSHION	1				0	0
210	K2561-54370	CUSHION	1				0.001	0.0022
220	K2561-42852	PLATE	1				0.007	0.0154
230	K1122-91320	BOLT SHORT SQU.NECK	2				0.01	0.022
240	75599-33012	WASHER SPRING	2				0.002	0.0044
240	04512-60080	WASHER SPRING	2		↔		0.002	0.0044
250	02114-50080	NUT	2				0.005	0.011

BRAKE PEDAL

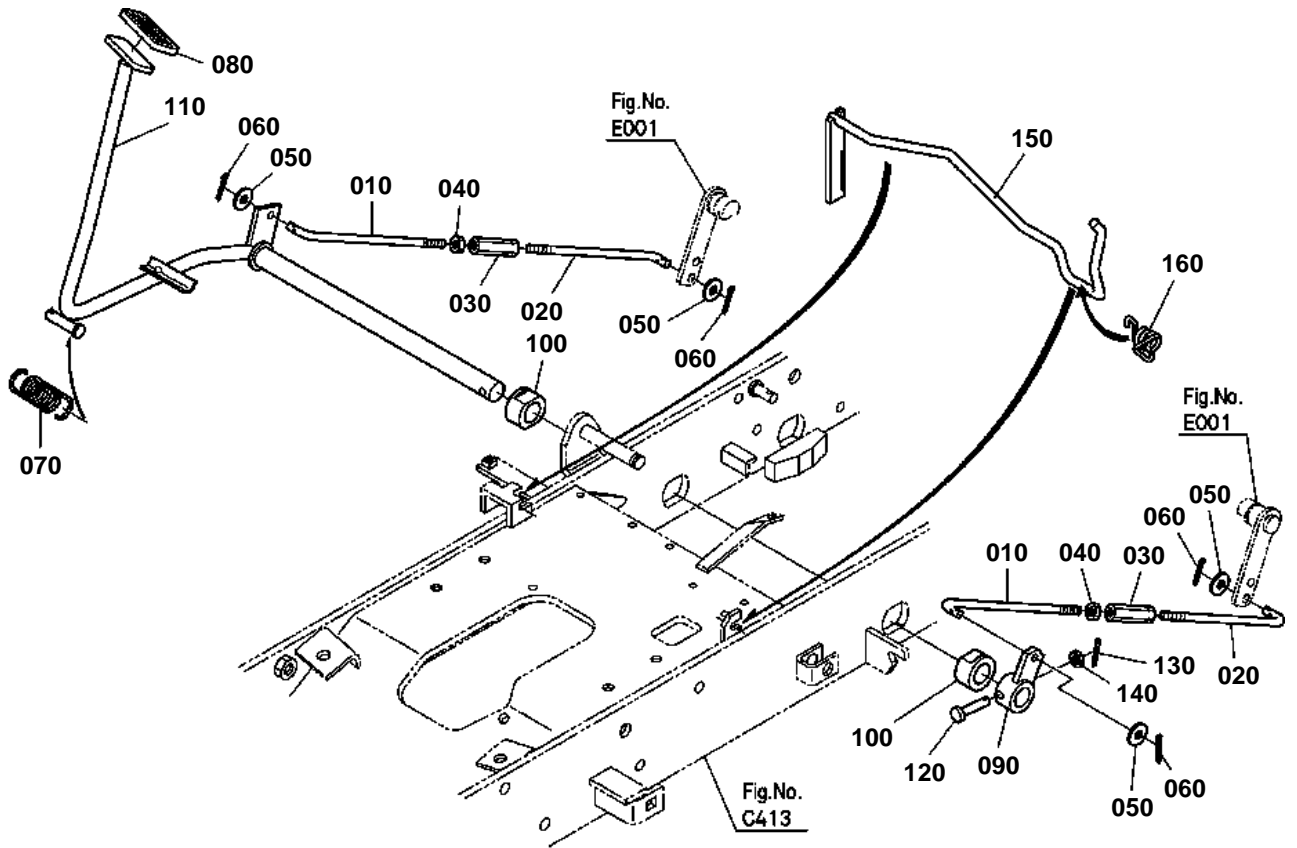

K2591-015-11

**BRAKE PEDAL**

↔ Interchangeable; ≠ not interchangeable; ← new for old; → old for new

REF.No	Part No.	Description	Q'ty	S.No.	I/C	REMARKS	Weight (kgf)	Weight (lb)
010	K2561-43110	ROD BRAKE	2				0.12	0.264
020	K2561-43120	ROD LEFT HAND THREAD	2				0.095	0.209
030	K2561-43150	TURNBUCKLE	2				0.07	0.154
040	75599-31023	NUT	2				0.006	0.0132
050	04013-60100	WASHER PLAIN	4				0.003	0.0066
060	75599-53152	PIN COTTER	4				0.001	0.0022
070	K2561-43140	SPRING RETURN	1				0.03	0.066
080	K1122-43150	COVER BRAKE PEDAL	1				0.022	0.0484
090	K2561-43160	ARM BRAKE	1				0.198	0.4356
100	K2561-43180	BUSH	2				0.099	0.2178
110	K2561-43170	PEDAL BRAKE	1				0	0
120	75599-51440	PIN CLEVIS	1				0.044	0.0968
130	75599-53173	PIN COTTER	1				0.002	0.0044
140	75599-32014	WASHER PLAIN	1				0.005	0.011
140	0Y401-50070	WASHER PLAIN	1			↔	0.043	0.0946
150	K2563-43210	PEDAL PARKING	1				0	0
160	K2561-43230	SPRING PARKING	1				0.01	0.022

DIFFERENTIAL LOCK PEDAL

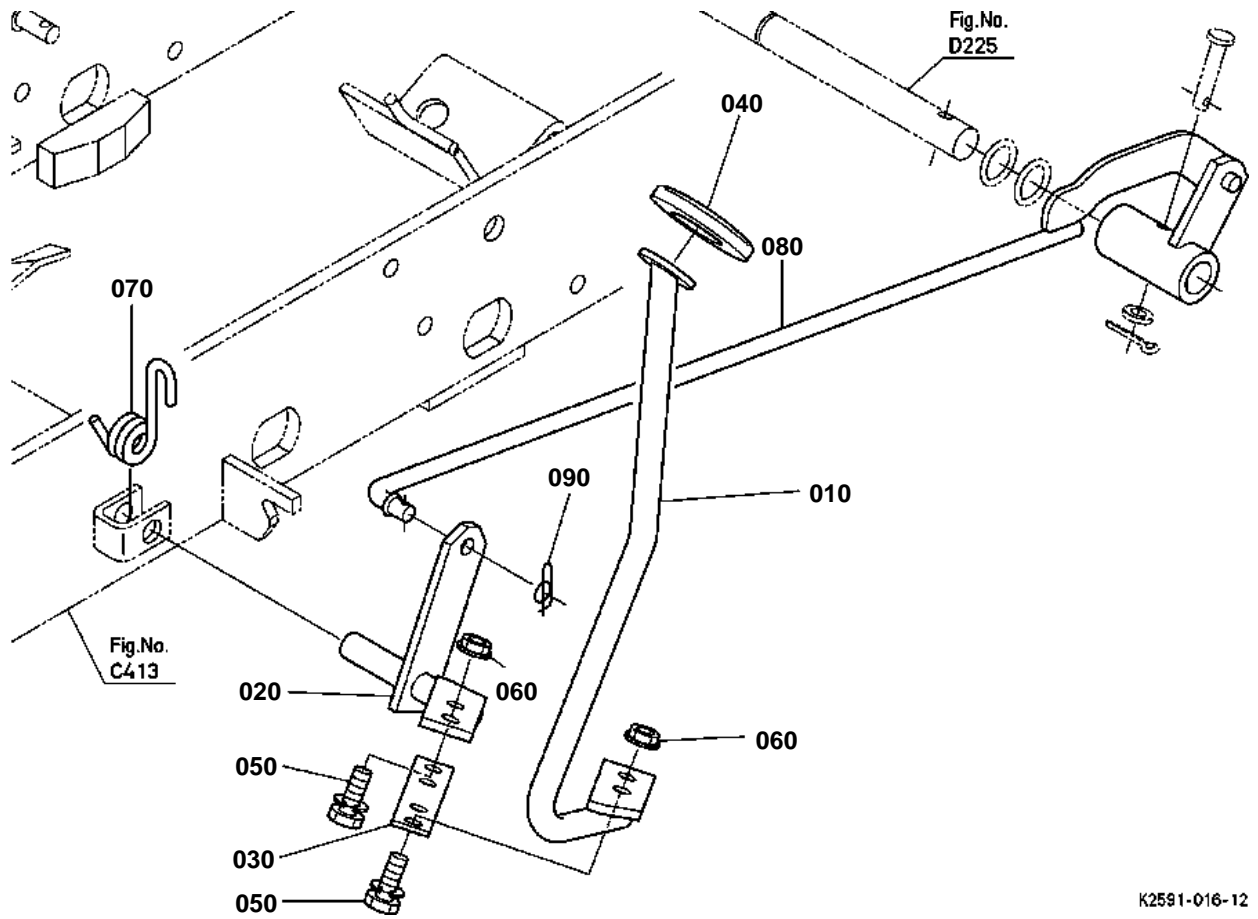

K2591-016-12

## OLD PARTS

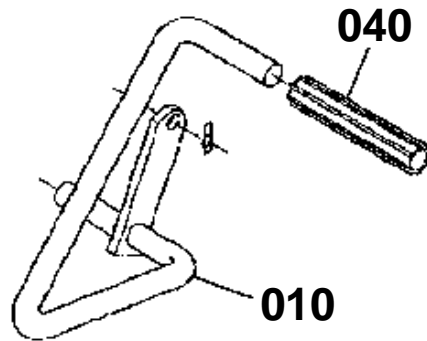

K2591-829-11





## DIFFERENTIAL LOCK PEDAL

↔ Interchangeable; ≠ not interchangeable; ← new for old; → old for new

REF.No	Part No.	Description	Q'ty	S.No.	I/C	REMARKS	Weight (kgf)	Weight (lb)
010	K2571-45510	PEDAL DIFF.LOCK	1				0.2	0.44
020	K2571-45550	SHAFT DIFF.LOCK	1				0.24	0.528
030	K2571-45560	PLATE DIFF.LOCK	1				0.04	0.088
040	36919-62320	RUBBER PEDAL	1				0.008	0.0176
050	01123-50820	BOLT	4				0.011	0.0242
060	02751-50080	NUT FLANGE	4				0.006	0.0132
070	K2561-45520	SPRING DIFF.LOCK PDL	1				0.04	0.088
080	K2591-45530	ROD COMP DIFF.LOCK	1				0.45	0.99
090	K1211-91120	RUE RING COTTER	1				0.001	0.0022

FRONT DIFFERENTIAL CASE

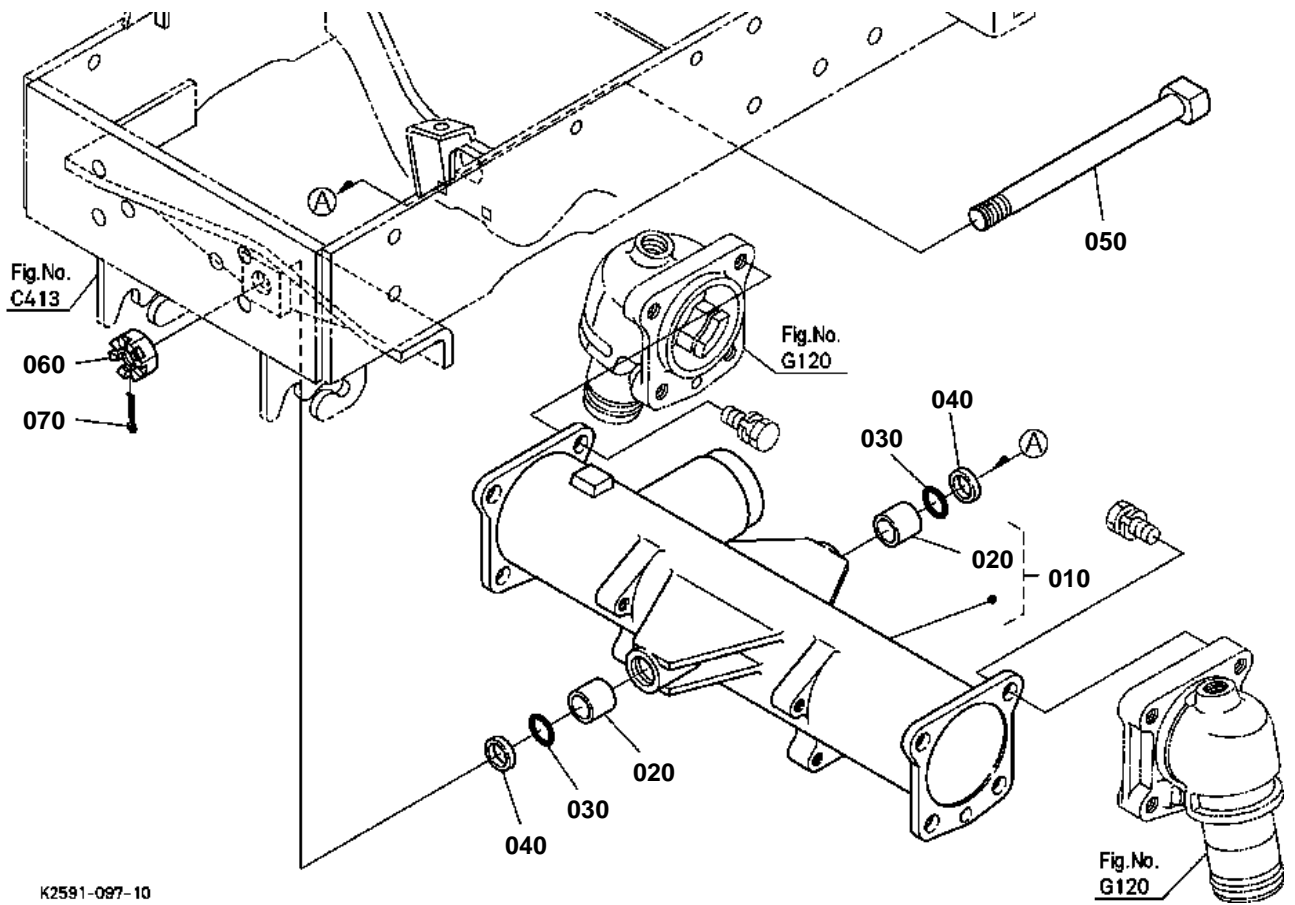

K2591-097-10



## FRONT DIFFERENTIAL CASE

↔ Interchangeable; ≠ not interchangeable; ← new for old; → old for new

REF.No	Part No.	Description	Q'ty	S.No.	I/C	REMARKS	Weight (kgf)	Weight (lb)
010	K2561-90200	ASSY CASE FRONT	1				9.9	21.78
020	08511-02025	BUSH	2				0.02	0.044
030	67817-37190	O RING	2				0.001	0.0022
040	K2561-15250	RING BACK UP	2				0.001	0.0022
050	K2561-15133	SHAFT CENTER	1				0.66	1.452
060	K2561-15190	NUT	1				0.02	0.044
070	75599-53195	PIN COTTER	1				0.003	0.0066

FRONT DIFFERENTIAL

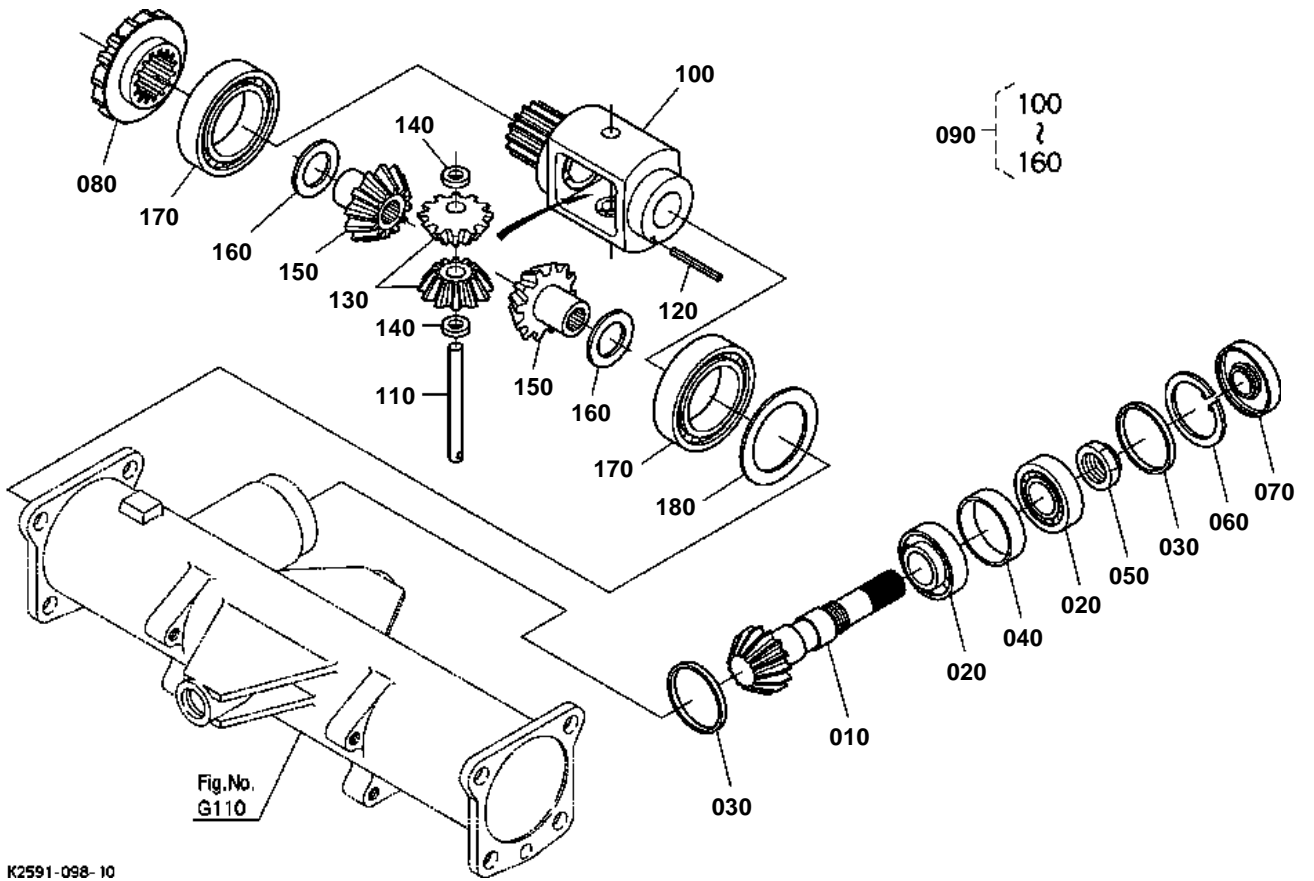

K2591-098-10

**FRONT DIFFERENTIAL**

↔ Interchangeable; ≠ not interchangeable; ← new for old; → old for new

REF.No	Part No.	Description	Q'ty	S.No.	I/C	REMARKS	Weight (kgf)	Weight (lb)
010	K2561-15712	SHAFT GEAR	1			11T	0.5	1.1
020	08711-30205	BEARING TAPER-ROLLER	2				0.148	0.3256
030	6C040-56620	COLLAR	2			4.5mm	0.01	0.022
030	37410-58120	COLLAR	2			4.0mm	0.01	0.022
030	37410-58130	COLLAR	2			4.1mm	0.01	0.022
030	37410-58140	COLLAR	2			4.2mm	0.01	0.022
030	6C040-56630	COLLAR	2			3.9mm	0.009	0.0198
030	37410-58150	COLLAR	2			3.8mm	0.01	0.022
030	37410-58160	COLLAR	2			3.4mm	0.01	0.022
030	37410-56660	COLLAR	2			4.6mm	0.011	0.0242
030	37410-58170	COLLAR	2			3.6mm	0.01	0.022
030	37410-56680	COLLAR	2			4.4mm	0.015	0.033
040	37410-56690	COLLAR	1				0.04	0.088
050	37410-56710	NUT	1				0.03	0.066
060	04611-00520	CIR CLIP INTERNAL	1				0.009	0.0198
070	59700-45520	SEAL OIL	1				0.023	0.0506
080	K2561-15910	GEAR BEVEL	1			20T	0.37	0.814
090	K2561-16010	ASSY DIFF. FRONT	1				1.29	2.838
100	K2561-16020	CASE DIFF.FRONT	1				0.94	2.068
110	K2561-16120	SHAFT DIFF.PINION	1				0.045	0.099
120	05411-00440	PIN SPRING	1				0.002	0.0044
130	K2561-16130	GEAR BEVEL	2			10T	0.05	0.11
140	K2561-16050	SHIM	2			3.5mm	0.006	0.0132
140	K2561-16060	SHIM	2			3.3mm	0.005	0.011
140	K2561-16070	SHIM	2			3.7mm	0.006	0.0132
140	K2561-16080	SHIM	2			3.9mm	0.006	0.0132
150	K2561-16140	GEAR BEVEL	2			14T	0.11	0.242
160	37410-56930	SHIM	2			1.0mm	0.005	0.011
160	37410-56920	SHIM	2			0.8mm	0.005	0.011
160	37410-56940	SHIM	2			1.2mm	0.01	0.022
170	08101-06010	BEARING BALL	2				0.262	0.5764
180	66611-15150	SHIM DIFF.SIDE	1				0.002	0.0044

DIFFERENTIAL GEAR SHAFT

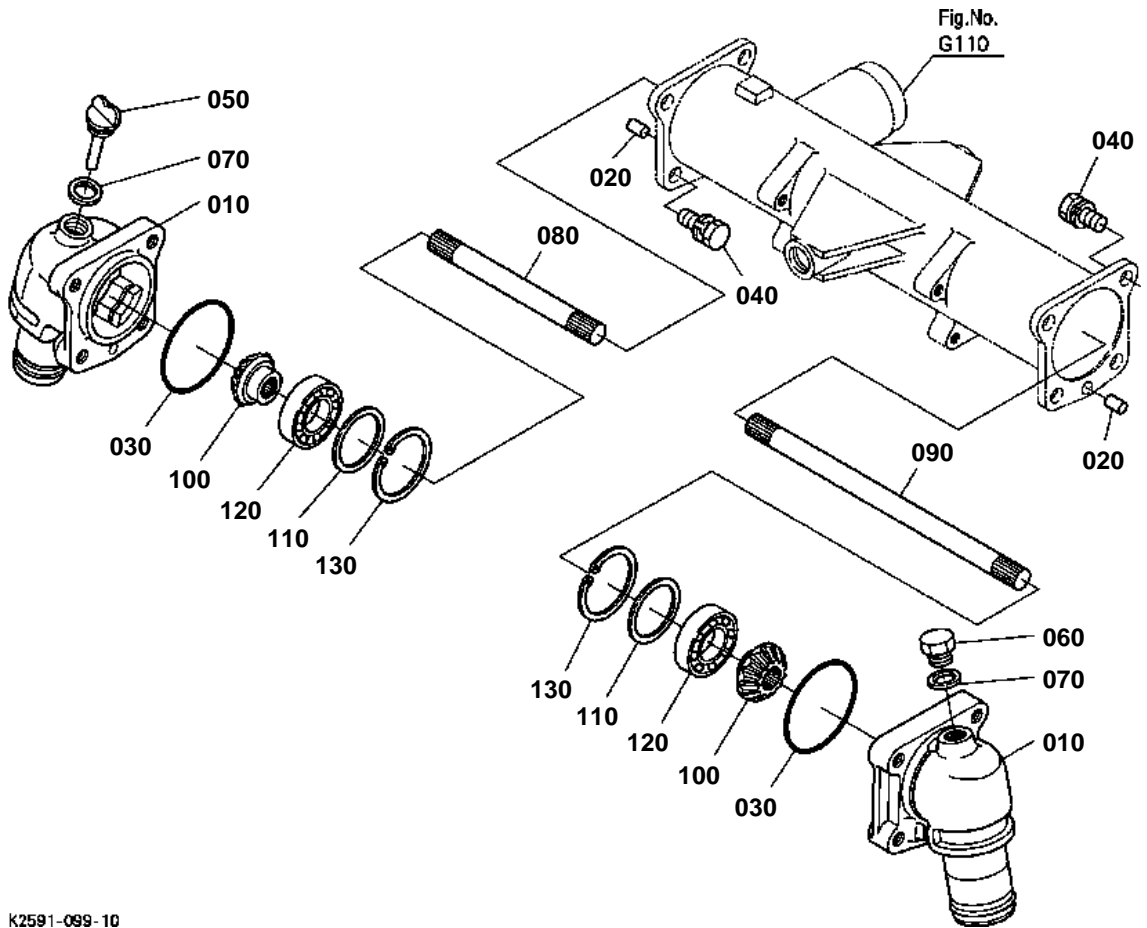

K2591-099-10



## DIFFERENTIAL GEAR SHAFT

↔ Interchangeable; ≠ not interchangeable; ← new for old; → old for new

REF.No	Part No.	Description	Q'ty	S.No.	I/C	REMARKS	Weight (kgf)	Weight (lb)
010	K2561-15222	CASE BEVEL GEAR	2				2.82	6.204
020	05012-01020	PIN STRAIGHT	2				0.013	0.0286
030	04811-50850	O RING	2				0.003	0.0066
040	01133-51230	BOLT	8				0.04	0.088
050	K2561-15240	GAUGE OIL	1				0.011	0.0242
060	06331-45020	PLUG	1				0.08	0.176
070	04717-02000	WASHER WITH RUBBER	2				0.004	0.0088
080	K2561-16220	SHAFT YOKE RH	1				0.42	0.924
090	K2561-16210	SHAFT YOKE LH	1				0.7	1.54
100	K2561-16230	GEAR BEVEL F	2			12T	0.2	0.44
110	6C040-57130	SHIM	2			1.0mm	0.008	0.0176
110	6C040-57140	SHIM	2			0.8mm	0.006	0.0132
110	6C040-57150	SHIM	2			1.2mm	0.009	0.0198
110	6C040-57160	SHIM	2			1.4mm	0.011	0.0242
120	08101-06206	BEARING BALL	2				0.196	0.4312
130	04611-00620	CIR CLIP INTERNAL	2				0.011	0.0242

FRONT AXLE CASE

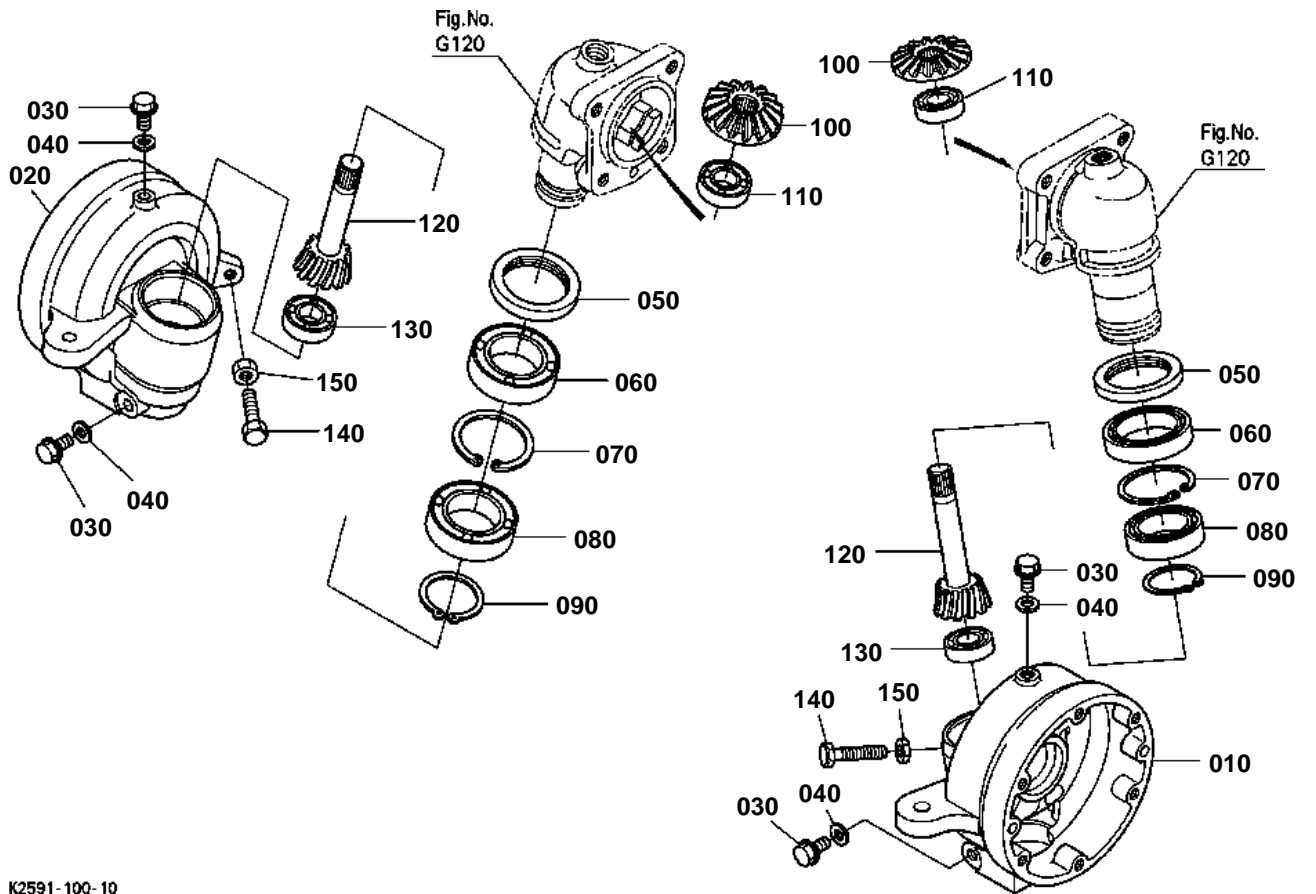

K2591-100-10





## FRONT AXLE CASE

↔ Interchangeable; ≠ not interchangeable; ← new for old; → old for new

REF.No	Part No.	Description	Q'ty	S.No.	I/C	REMARKS	Weight (kgf)	Weight (lb)
010	K2561-15412	CASE FRONT GEAR LH	1				4.84	10.648
020	K2561-15420	CASE FRONT GEAR RH	1				4.66	10.252
030	01774-51010	BOLT FLANGE	4				0.08	0.176
040	04717-01000	WASHER WITH RUBBER	4				0.001	0.0022
050	6A320-56220	SEAL OIL	2				0.06	0.132
060	08101-06910	BEARING BALL	2				0.14	0.308
070	04611-00680	CIR CLIP INTERNAL	2				0.016	0.0352
080	08101-06909	BEARING BALL	2				0.135	0.297
090	04612-00450	CIR CLIP EXTERNAL	2				0.007	0.0154
100	K2561-16280	GEAR BEVEL F	2			15T	0.21	0.462
110	08101-06204	BEARING BALL	2				0.102	0.2244
120	K2561-16310	SHAFT BEVEL GEAR	2			9T	0.5	1.1
130	08101-06304	BEARING BALL	2				0.146	0.3212
140	66711-13320	BOLT ADJUSTING	2				0.028	0.0616
150	02118-50100	NUT	2				0.005	0.011

FRONT AXLE

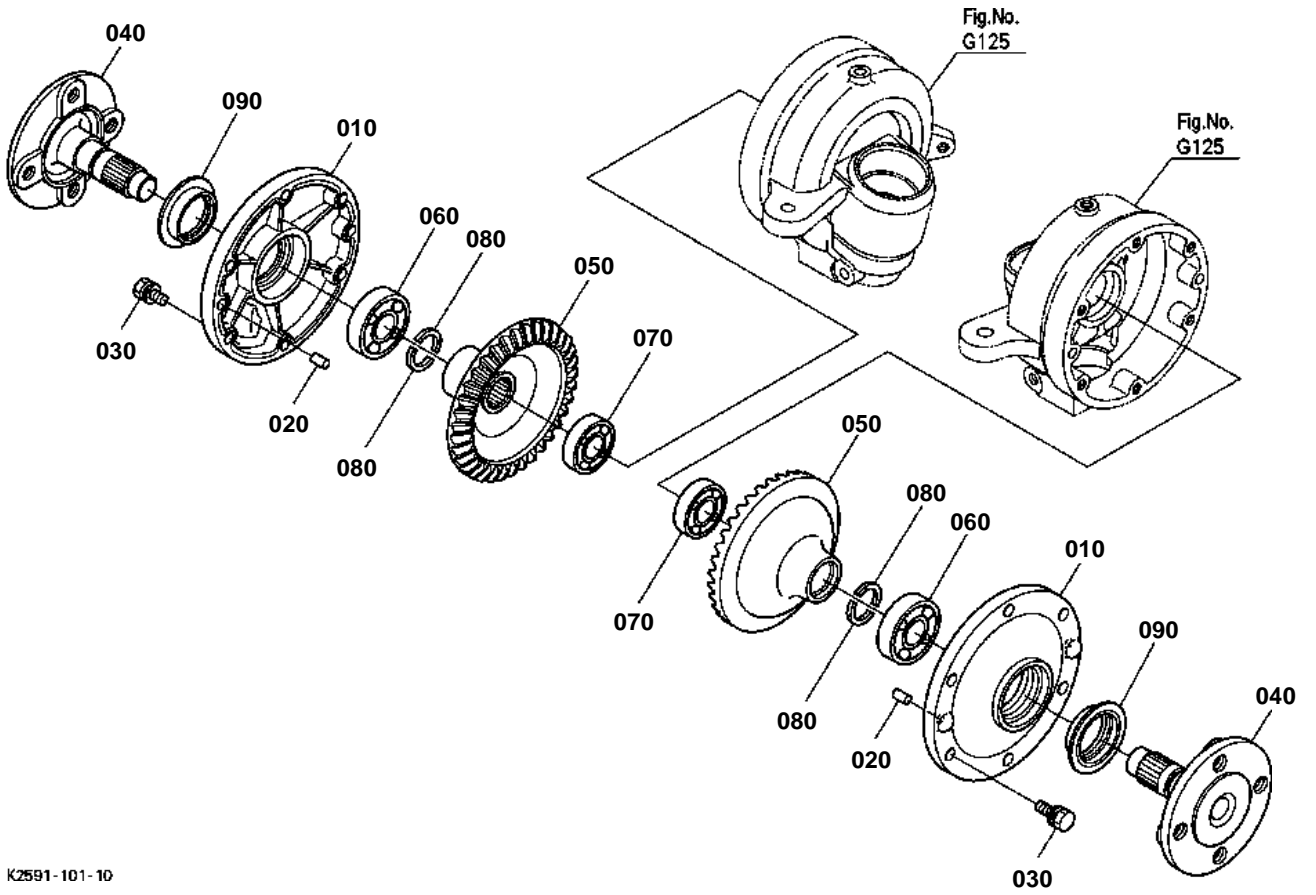

K2591-101-10

**FRONT AXLE**

↔ Interchangeable; ≠ not interchangeable; ← new for old; → old for new

REF.No	Part No.	Description	Q'ty	S.No.	I/C	REMARKS	Weight (kgf)	Weight (lb)
010	K2561-15480	COVER GEAR CASE	2				0.52	1.144
020	05012-00820	PIN STRAIGHT	4				0.008	0.0176
030	01133-51030	BOLT	12				0.025	0.055
040	K2561-16410	SHAFT FRONT AXLE	2				1.62	3.564
050	K2561-16320	GEAR BEVEL	2			36T	2.16	4.752
060	08101-06206	BEARING BALL	2				0.196	0.4312
070	08101-06205	BEARING BALL	2				0.14	0.308
080	67156-56820	COLLAR SET	4				0.004	0.0088
090	37410-57340	SEAL OIL	2				0.045	0.099

STEERING HANDLE

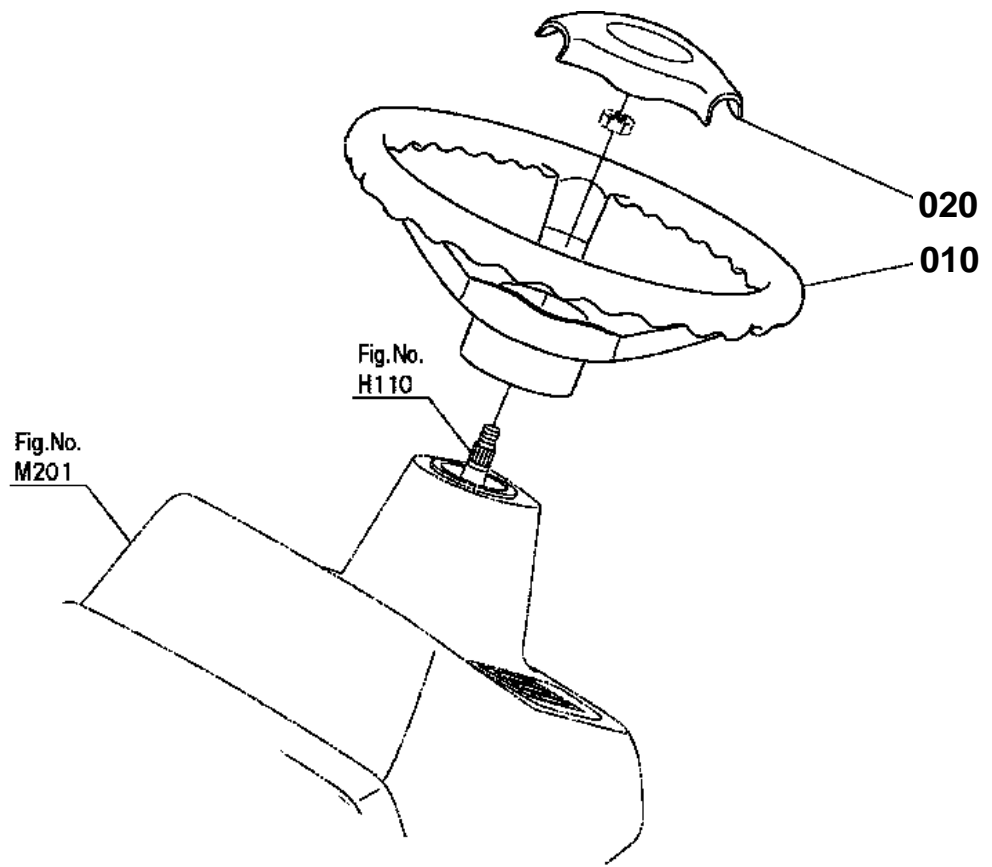

K2571-046-10



## STEERING HANDLE

↔ Interchangeable; ≠ not interchangeable; ← new for old; → old for new

REF.No	Part No.	Description	Q'ty	S.No.	I/C	REMARKS	Weight (kgf)	Weight (lb)
010	K2561-41120	WHEEL STEERING	1				1.4	3.08
020	K2561-41130	CAP STEERING WHEEL	1				0.06	0.132

STEERING CONTROLLER

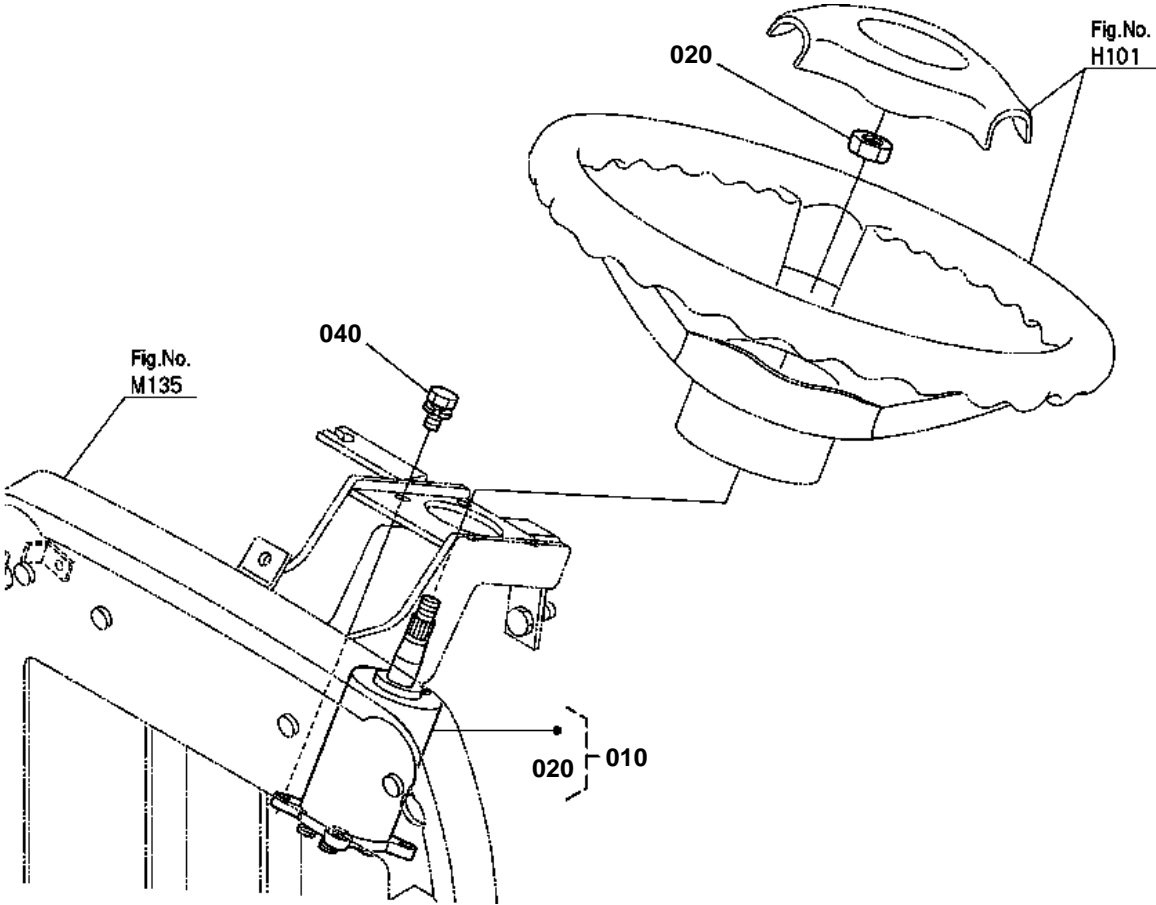

K2591-044-12

# OLD PARTS

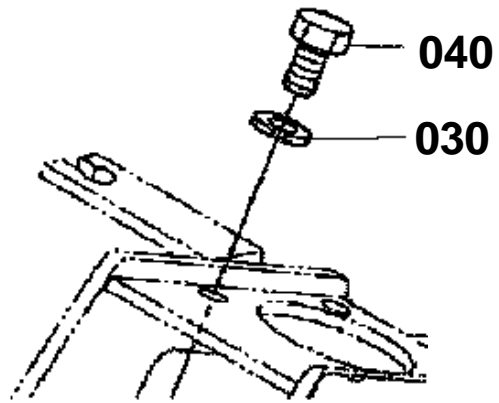

K2591-830-11



## STEERING CONTROLLER

↔ Interchangeable; ≠ not interchangeable; ← new for old; → old for new

REF.No	Part No.	Description	Q'ty	S.No.	I/C	REMARKS	Weight (kgf)	Weight (lb)
010	K2561-41510	ASSY STEERING POWER	1				2.62	5.764
020	75599-31047	HEX.JUM NUT	1				0.03	0.066
040	01123-50820	BOLT	4				0.011	0.0242



STEERING LINKAGE

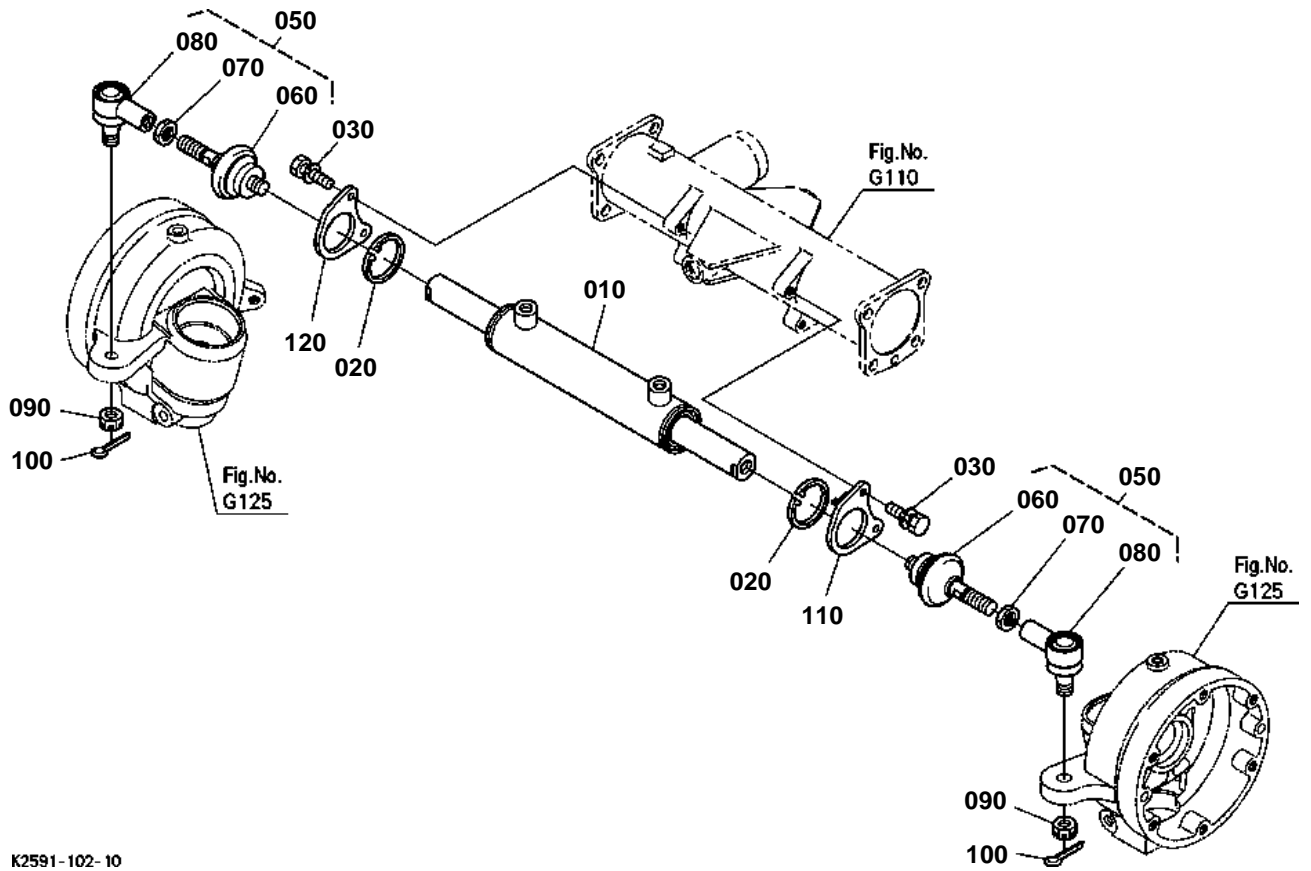

K2591-102-10

## OLD PARTS

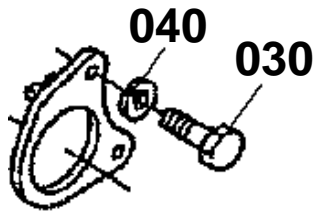

K2591-818-11



## STEERING LINKAGE

↔ Interchangeable; ≠ not interchangeable; ← new for old; → old for new

REF.No	Part No.	Description	Q'ty	S.No.	I/C	REMARKS	Weight (kgf)	Weight (lb)
010	K2561-16500	CYLINDER STEERING	1				3.3	7.26
020	04612-00500	CIR CLIP EXTERNAL	2				0.009	0.0198
030	01133-51030	BOLT	4				0.025	0.055
050	K2561-16610	TIE ROD STEERING	2				0.55	1.21
060	K2561-01630	JOINT AXIAL BALL	2				0.313	0.6886
070	K2561-01640	NUT	2				0.018	0.0396
080	K2561-01650	JOINT BALL DIRECTION	2				0.255	0.561
090	66591-56780	NUT	2				0.01	0.022
100	05511-52525	PIN SPLIT	2				0.001	0.0022
110	K2561-16620	HOLDER LH	1				0.154	0.3388
120	K2561-16630	HOLDER RH	1				0.146	0.3212

STEERING CYLINDER [COMPONENT PARTS]

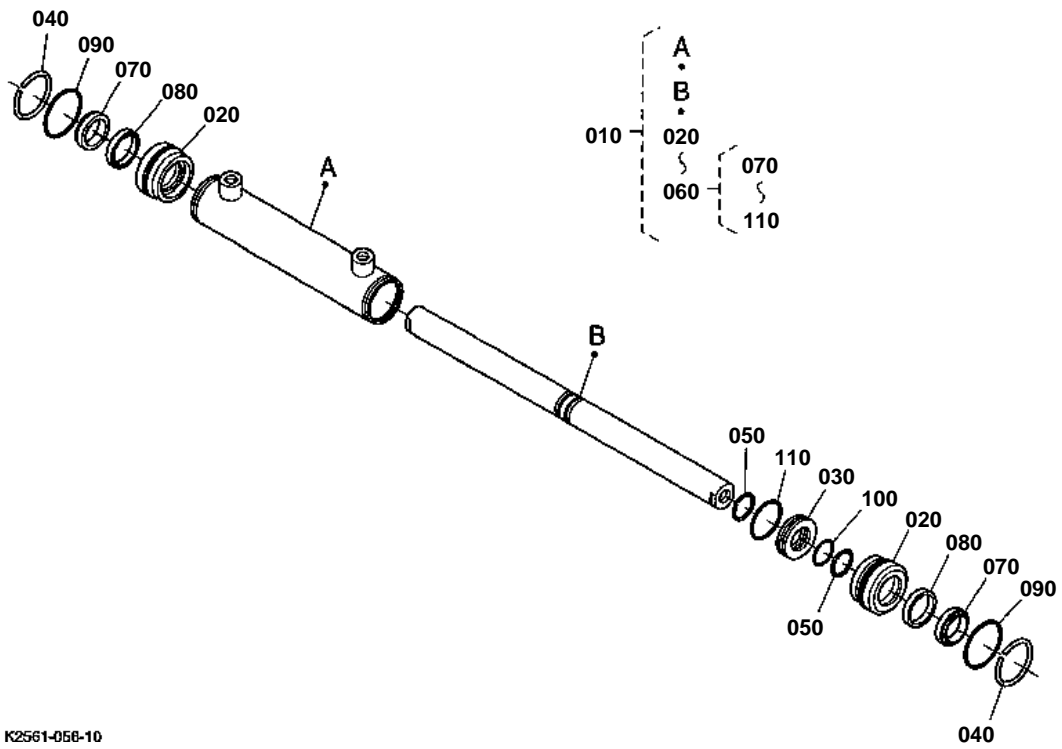

K2561-056-10



## STEERING CYLINDER [COMPONENT PARTS]

↔ Interchangeable; ≠ not interchangeable; ← new for old; → old for new

REF.No	Part No.	Description	Q'ty	S.No.	I/C	REMARKS	Weight (kgf)	Weight (lb)
010	K2561-16500	CYLINDER STEERING	1				3.3	7.26
020	K2561-16510	CAP END	2				0.12	0.264
030	K2561-16520	PISTON CENTER	1				0.052	0.1144
040	K2561-16530	CIR CLIP INTERNAL	2				0.008	0.0176
050	K2561-16540	CIR CLIP EXTERNAL	2				0.004	0.0088
060	K2561-16600	KIT SEAL	1				0.032	0.0704
070	K2561-16550	RING WIPER	2				0.05	0.11
080	K2561-16560	RING SEAL	2				0.01	0.022
090	K2561-16570	O-RING CAP	2				0	0
100	K2561-16580	O-RING ROD	1				0	0
110	K2561-16590	O-RING PISTON	1				0	0

HYDRAULIC OIL LINE(SUCTION)

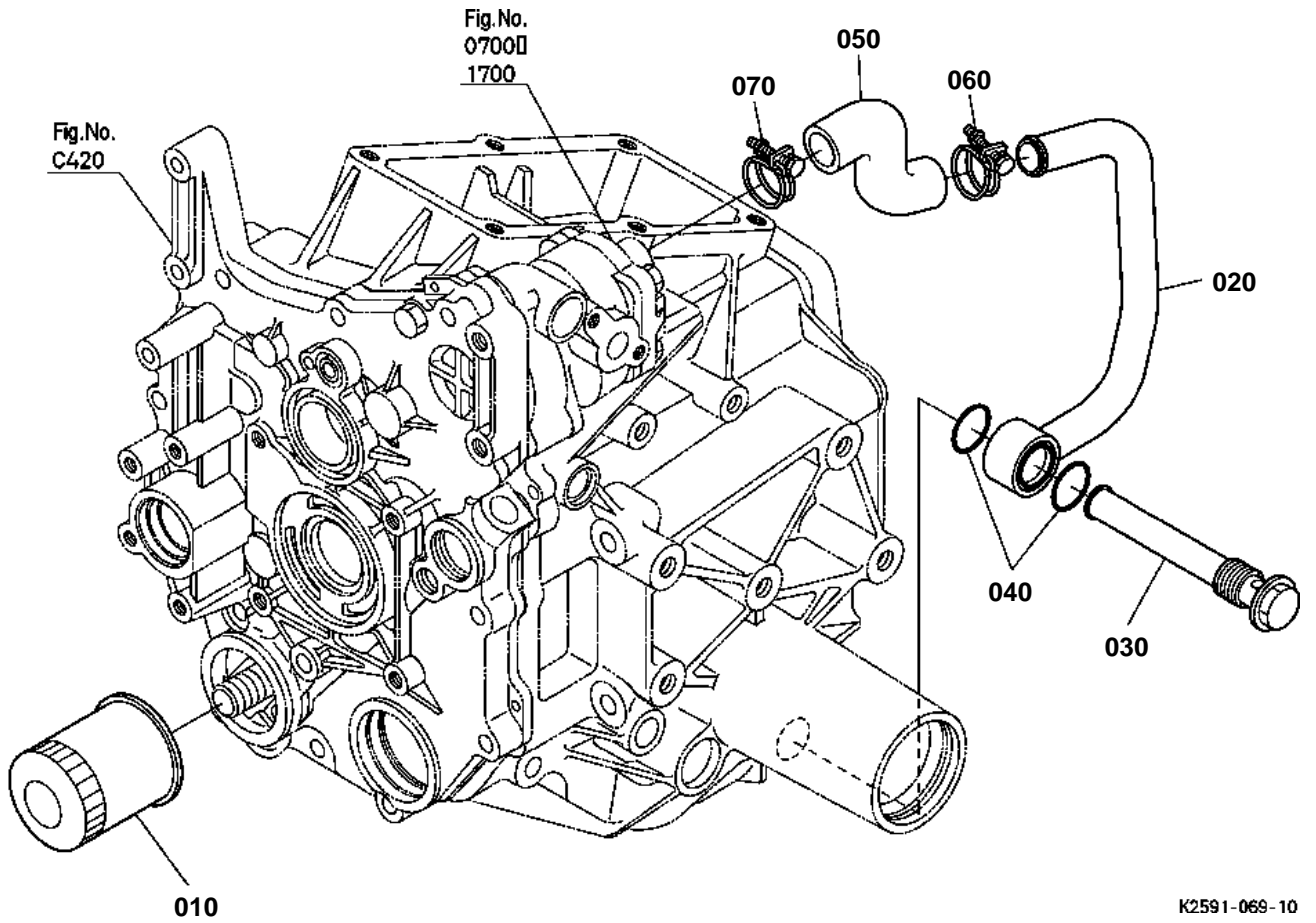

K2591-069-10



## HYDRAULIC OIL LINE(SUCTION)

↔ Interchangeable; ≠ not interchangeable; ← new for old; → old for new

REF.No	Part No.	Description	Q'ty	S.No.	I/C	REMARKS	Weight (kgf)	Weight (lb)
010	K2561-36990	CARTRIDGE OIL FILTER	1				0.38	0.836
020	K2561-36512	PIPE SUCTION	1				0.35	0.77
030	66021-36390	FILTER OIL	1				0.185	0.407
040	04811-10300	O RING	2				0.001	0.0022
050	K2561-36530	HOSE SUCTION	1				0.08	0.176
060	67980-58640	CLAMP HOSE	1				0.02	0.044
070	67955-58630	CLAMP HOSE	1				0.025	0.055

HYDRAULIC OIL LINE(DELIVERY)

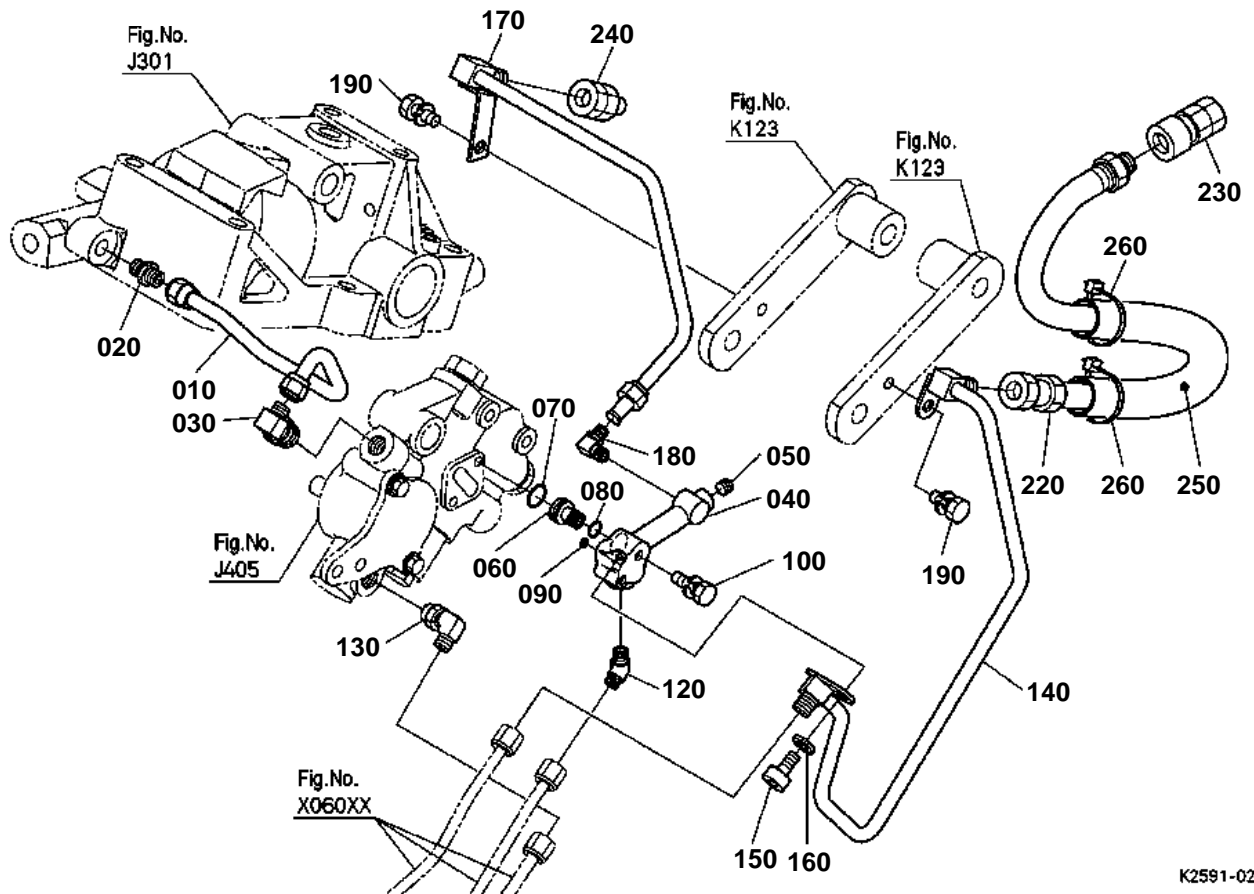

K2591-021-13



## OLD PARTS

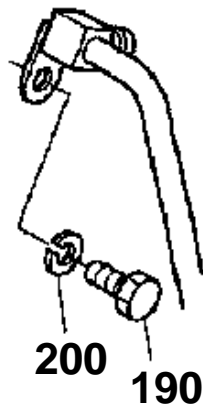
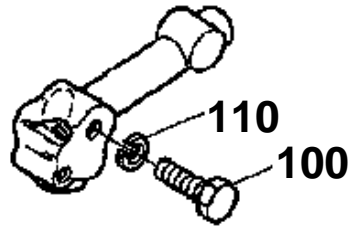

**K2591-831-11**



# HYDRAULIC OIL LINE(DELIVERY)

↔ Interchangeable; ≠ not interchangeable; ← new for old; → old for new

REF.No	Part No.	Description	Q'ty	S.No.	I/C	REMARKS	Weight (kgf)	Weight (lb)
010	K2561-36610	PIPE DELIVERY P	1				0.1	0.22
020	K2561-36620	JOINT PIPE	1				0.035	0.077
030	K2561-36630	CONNECTOR	1				0.06	0.132
040	K2563-37410	BLOCK HYD.OUTLET	1				0.376	0.8272
050	31351-37160	PLUG	1				0.003	0.0066
060	K2563-37490	COLLAR	1				0.03	0.066
070	04816-00180	O RING	1				0.002	0.0044
080	04816-00110	O RING	1				0.001	0.0022
090	75538-68130	O RING	2				0.011	0.0242
100	01123-50845	BOLT	2				0.02	0.044
120	75538-68150	JOINT ELBOW	1				0.034	0.0748
130	75595-64200	ASSY ELBOW ADJUSTA	1				0.52	1.144
130	K2561-36630	CONNECTOR	1		↔		0.06	0.132
140	K2591-37510	PIPE DELIVERY BH	1				0.25	0.55
150	01311-10812	BOLT HEX-SOC-HD	1				0.009	0.0198
160	75599-33012	WASHER SPRING	1				0.002	0.0044
160	04512-60080	WASHER SPRING	1		↔		0.002	0.0044
170	K2591-37520	PIPE RETURN	1				0.2	0.44
180	K2561-36630	CONNECTOR	1				0.06	0.132
190	01123-50820	BOLT	2				0.011	0.0242
210	99999-99999	BLANK	2				0	0
220	K2591-37530	HOSE BH	1				0.2	0.44
230	75536-66320	COUPLER	1				0.13	0.286
240	75536-66220	NIPPLE	1				0.04	0.088
250	75538-66250	SLEEVE	1				0.003	0.0066
260	K1122-61230	CLAMP CORD	2				0.001	0.0022

HYDRAULIC OIL LINE(STEERING)

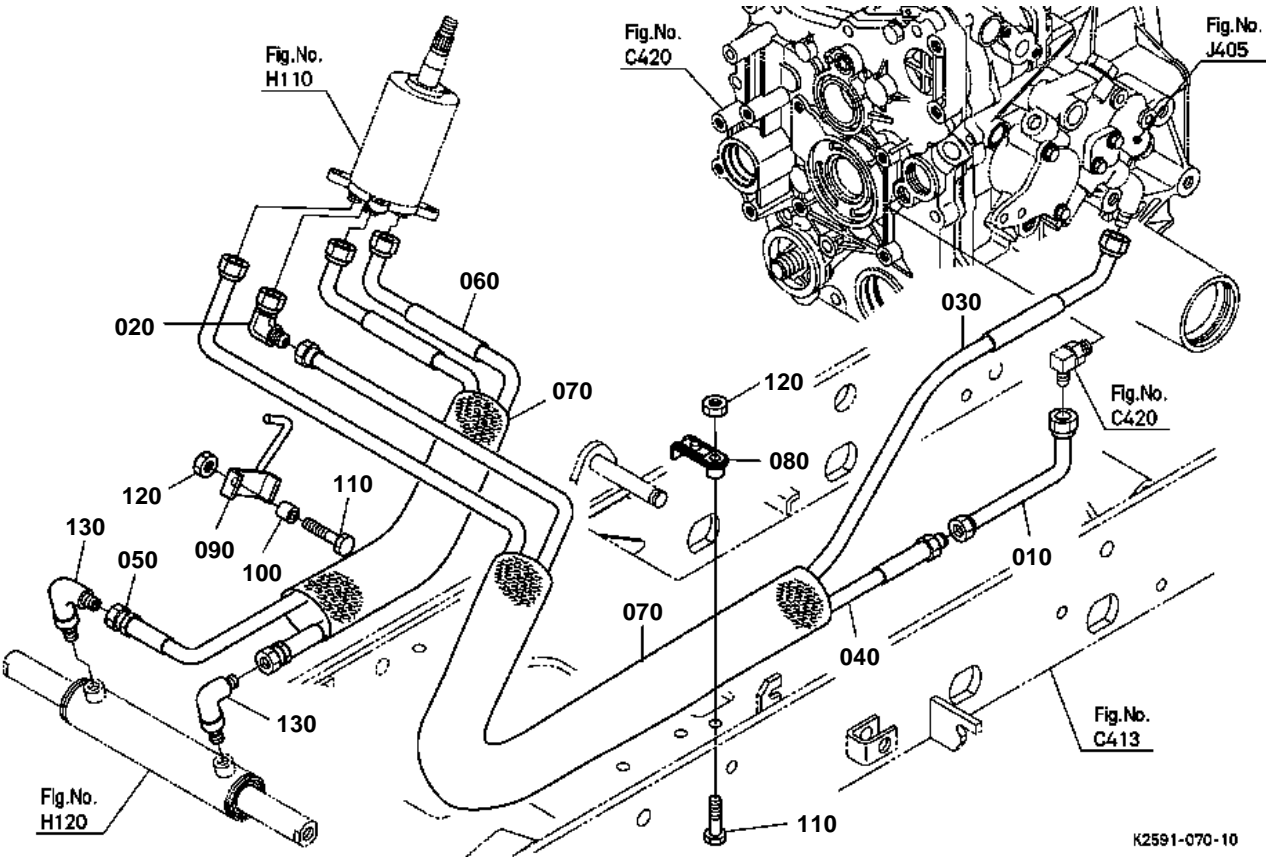

K2591-070-10

## OLD PARTS

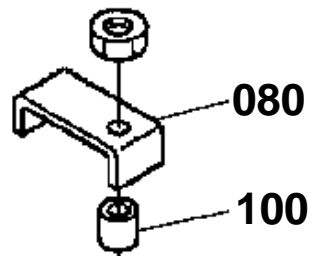
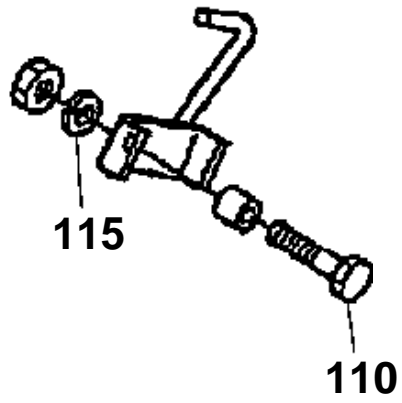

K2591-832-11



## HYDRAULIC OIL LINE(STEERING)

↔ Interchangeable; ≠ not interchangeable; ← new for old; → old for new

REF.No	Part No.	Description	Q'ty	S.No.	I/C	REMARKS	Weight (kgf)	Weight (lb)
010	K2561-41520	PIPE STEERING	1				0.07	0.154
020	K2561-41590	JOINT	1				0.059	0.1298
030	K2561-41530	HOSE IN STEERING	1				0.445	0.979
040	K2561-41540	HOSE OUT STEERING	1				0.413	0.9086
050	K2561-41610	HOSE PS LH	1				0.37	0.814
060	K2561-41620	HOSE PS RH	1				0.35	0.77
070	K2561-41636	TUBE GUARD	2				0.06	0.132
080	K2511-41650	CLAMP HOSE	1				0.02	0.044
090	K2561-41660	CLAMP HOSE F	1				0.078	0.1716
100	K2561-41670	COLLAR HOSE CLAMP	1				0.009	0.0198
110	01123-50840	BOLT	2				0.018	0.0396
120	02114-50080	NUT	2				0.005	0.011
130	K2561-41580	JOINT	2				0.08	0.176

HYDRAULIC CYLINDER

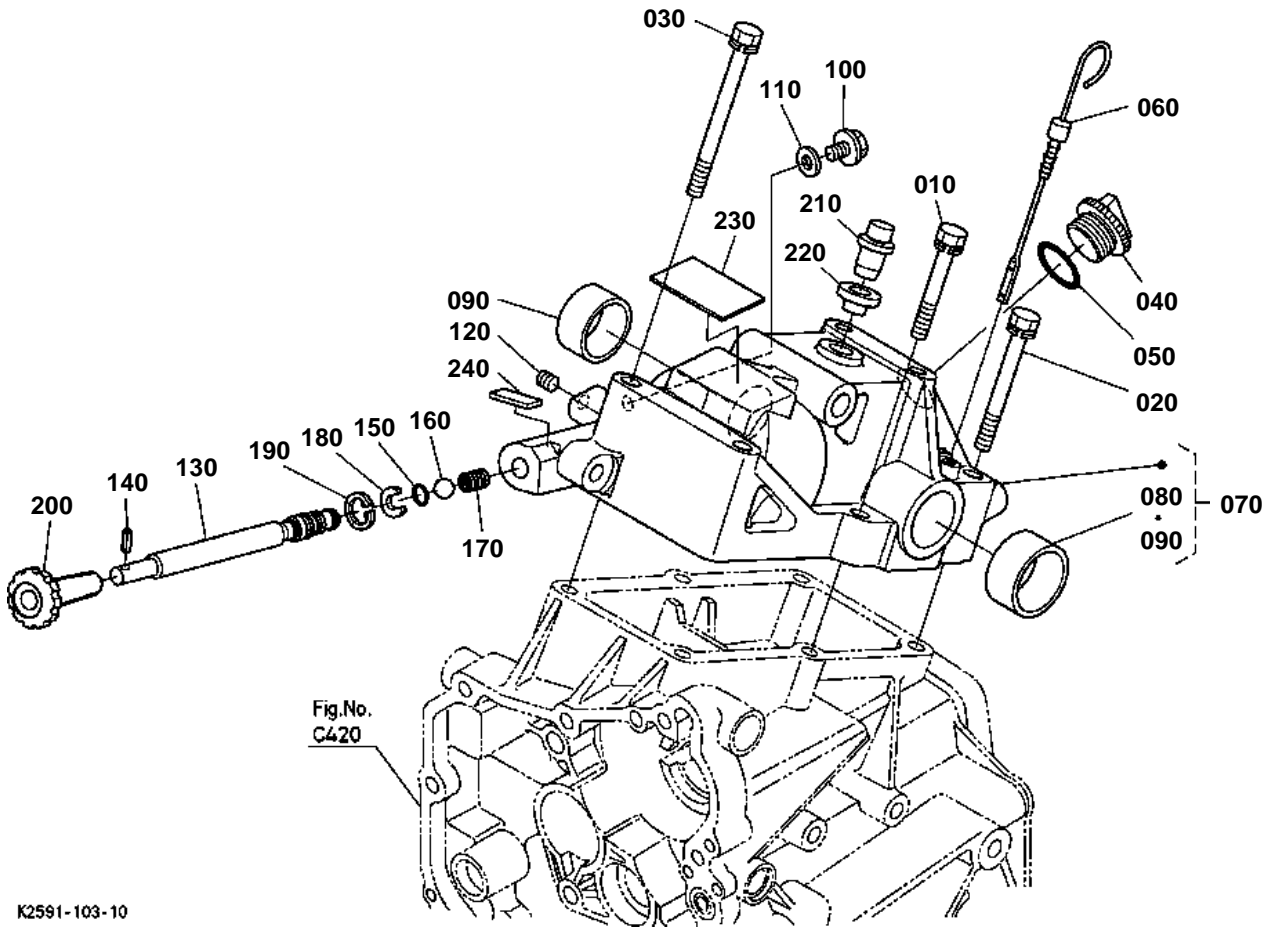

K2591-103-10



# HYDRAULIC CYLINDER

↔ Interchangeable; ≠ not interchangeable; ← new for old; → old for new

REF.No	Part No.	Description	Q'ty	S.No.	I/C	REMARKS	Weight (kgf)	Weight (lb)
010	01123-51055	BOLT	2				0.038	0.0836
020	01123-51070	BOLT	2				0.05	0.11
030	01123-51095	BOLT	2				0	0
040	38240-21410	PLUG	1				0.015	0.033
050	04811-50300	O RING	1				0	0
050	04817-50300	O RING	1		←		0.001	0.0022
060	K2561-36340	GAUGE OIL	1				0.015	0.033
070	K2561-36012	ASSY CASE CYLINDER	1				9.2	20.24
080	K2561-36030	BUSH	1				0.03	0.066
090	K2561-36040	BUSH	1				0.024	0.0528
100	37150-36730	PLUG	1				0.03	0.066
110	37150-36720	GASKET	1				0.01	0.022
120	31351-37160	PLUG	1				0.003	0.0066
130	K2561-36240	SHAFT HYD.ADJUST	1				0.16	0.352
140	05411-00414	PIN SPRING	1				0.001	0.0022
150	04810-00100	O RING	1				0	0
150	04817-00100	O RING	1		←		0.001	0.0022
160	07715-03209	BALL	1				0.002	0.0044
170	6C120-37440	SPRING	1				0.001	0.0022
180	6A320-37410	STOPPER	1				0.002	0.0044
190	04611-00190	CIR CLIP INTERNAL	1				0.001	0.0022
200	K2561-36310	GRIP	1				0.04	0.088
210	K2561-36330	BREATHER	1				0.008	0.0176
220	K2561-36350	BUSH	1				0.01	0.022
230	K2561-54790	CUSHION TANK UNDER	1				0.016	0.0352
240	K1122-57163	PLATE RUBBER	1				0.001	0.0022

HYDRAULIC PISTON/LIFT ARM

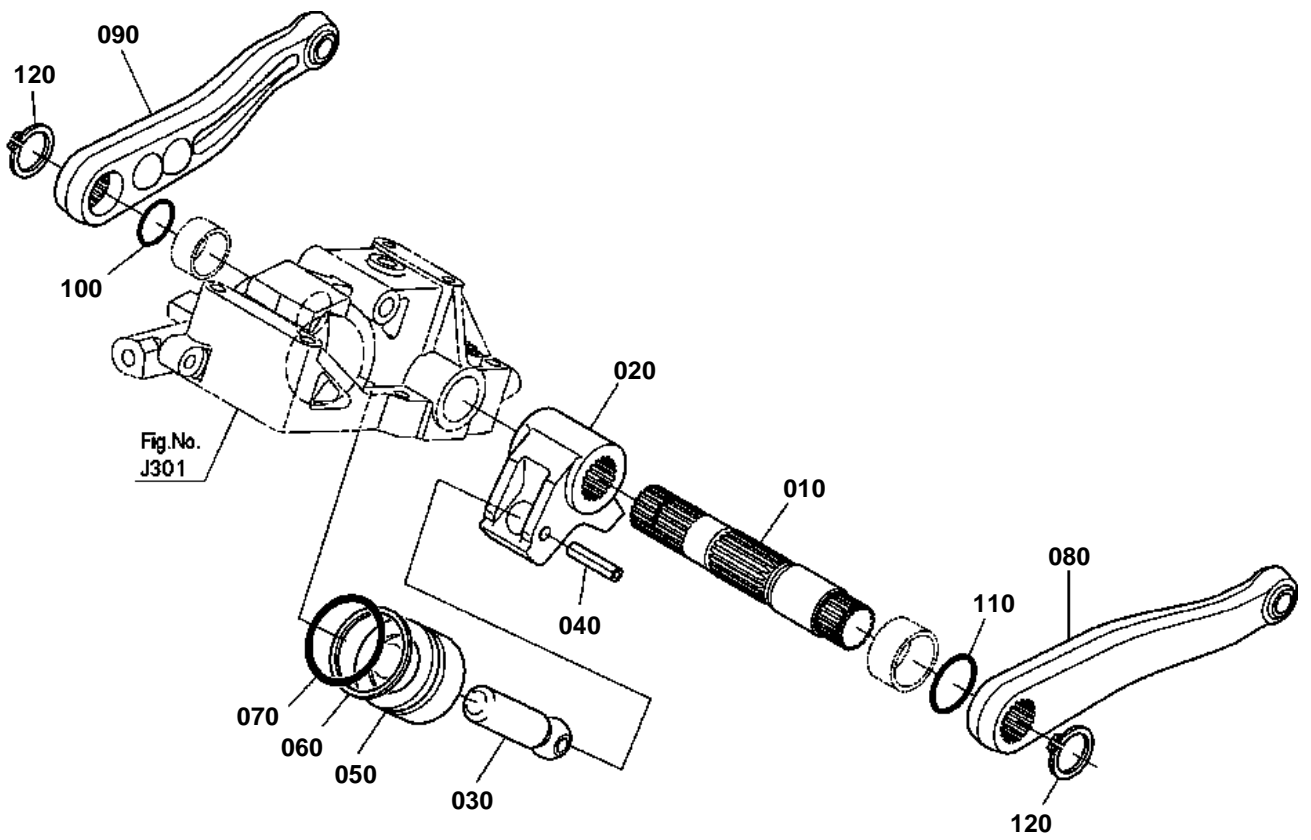

K2591-104-10





# HYDRAULIC PISTON/LIFT ARM

↔ Interchangeable; ≠ not interchangeable; ← new for old; → old for new

REF.No	Part No.	Description	Q'ty	S.No.	I/C	REMARKS	Weight (kgf)	Weight (lb)
010	K2561-36050	SHAFT HYD.ARM	1				1.37	3.014
020	K2561-36062	ARM HYDRAULIC	1				1.07	2.354
030	K2561-36122	ROD HYD.PISTON	1				0.27	0.594
040	05411-00640	PIN SPRING	1				0.006	0.0132
050	K2561-36110	PISTON HYD.	1				1.2	2.64
060	K2561-36140	RING BACK UP	1				0.005	0.011
070	04811-00700	O RING	1				0.008	0.0176
080	K2561-36072	ARM LIFT LH	1				1.66	3.652
090	K2561-36082	ARM LIFT RH	1				1.6	3.52
100	04811-00300	O RING	1				0	0
100	04816-00300	O RING	1		←		0.001	0.0022
110	04811-00320	O RING	1				0	0
110	04816-00320	O RING	1		←		0.003	0.0066
120	04612-00300	CIR CLIP EXTERNAL	2				0.003	0.0066

# CONTROL VALVE

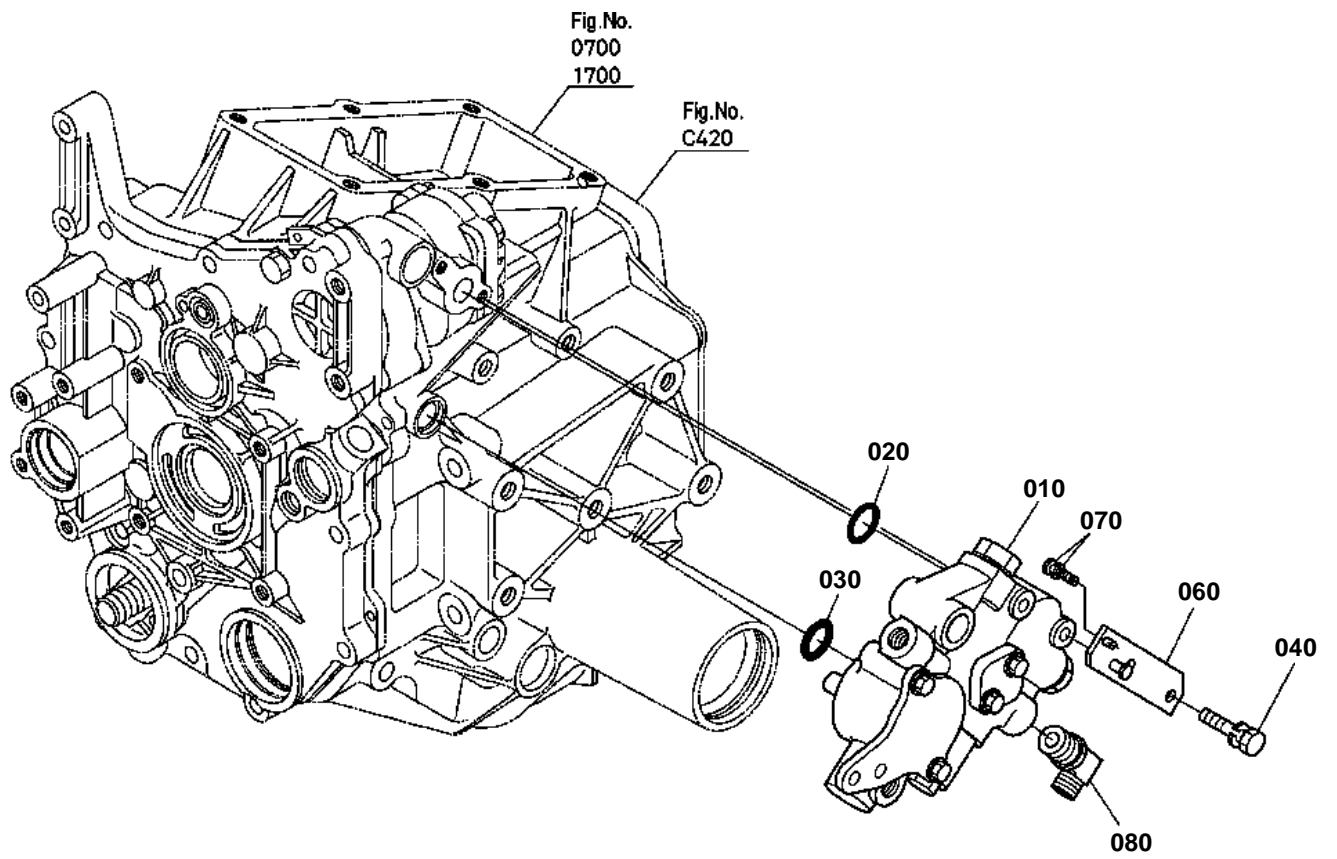

K2591-071-10

## OLD PARTS

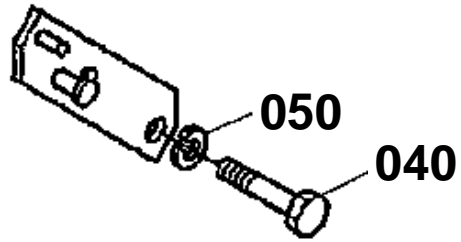

K2591-811-11



# CONTROL VALVE

↔ Interchangeable; ≠ not interchangeable; ← new for old; → old for new

REF.No	Part No.	Description	Q'ty	S.No.	I/C	REMARKS	Weight (kgf)	Weight (lb)
010	K2561-36402	ASSY VALVE CONTROL	1				3.14	6.908
020	04810-00180	O RING	1				0	0
020	04817-00180	O RING	1				0.003	0.0066
030	K2561-36560	O RING	1		←		0.008	0.0176
040	01123-50860	BOLT	2				0.002	0.0044
060	K2561-42680	STAY SWITCH CLUTCH	1				0	0
070	K2561-42690	BOLT	2				0.002	0.0044
080	K2561-36630	CONNECTOR	1				0.06	0.132

CONTROL VALVE [COMPONENT PARTS]

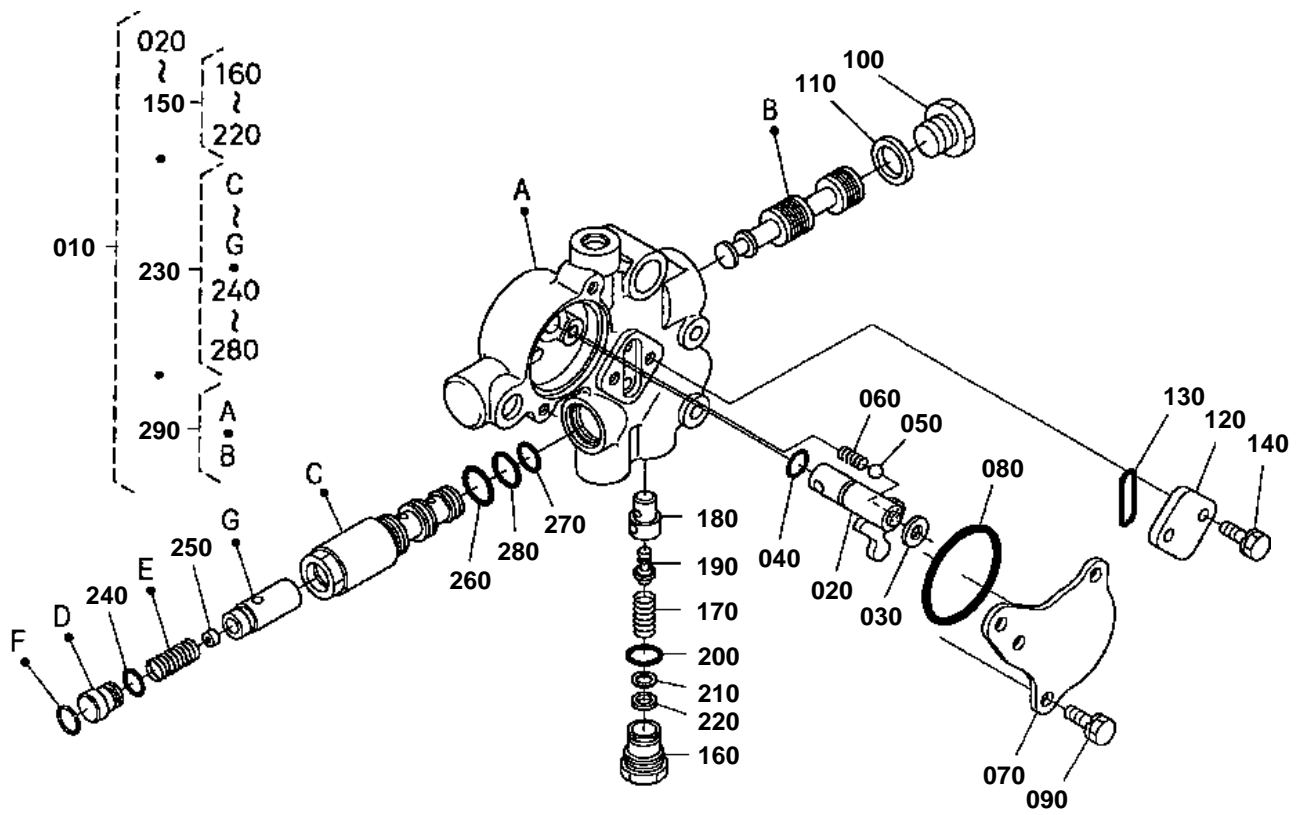

K2561-065-11

**CONTROL VALVE [COMPONENT PARTS]**

↔ Interchangeable; ≠ not interchangeable; ← new for old; → old for new

REF.No	Part No.	Description	Q'ty	S.No.	I/C	REMARKS	Weight (kgf)	Weight (lb)
010	K2561-36402	ASSY VALVE CONTROL	1				3.14	6.908
020	K2561-36440	ARM CONTROL VALVE	1				0.11	0.242
030	K2561-36450	WASHER THRUST	1				0.002	0.0044
040	04811-06110	O RING	1				0	0
040	04817-06110	O RING	1		←		0.001	0.0022
050	07715-00803	BALL	1				0.004	0.0088
060	67156-18150	SPRING SHIFT FORK	1				0.003	0.0066
070	K2561-36462	COVER	1				0.16	0.352
080	04811-06530	O RING	1				0.001	0.0022
090	01123-50820	BOLT	2				0.011	0.0242
100	06331-35020	PLUG	1				0.068	0.1496
110	04717-02000	WASHER WITH RUBBER	1				0.004	0.0088
120	6C040-36620	CAP	1				0.022	0.0484
130	37410-36630	O RING	1				0.001	0.0022
140	01123-50825	BOLT	2				0.013	0.0286
150	K2561-36700	ASSY VALVE RELIEF	1				0.06	0.132
160	K2561-36710	PLUG	1				0.05	0.11
170	31351-37920	SPRING RELIEF	1				0.02	0.044
180	31351-37930	SEAT RELIEF VALVE	1				0.02	0.044
190	31351-37940	POPPET	1				0.005	0.011
200	04811-10160	O RING	1				0.001	0.0022
210	31351-37950	SHIM	2			0.4mm	0.001	0.0022
210	31351-37960	SHIM	2			0.2mm	0.001	0.0022
210	31351-37970	SHIM	2			0.1mm	0.001	0.0022
220	04013-60050	WASHER PLAIN	2				0.001	0.0022
230	K2561-36800	VALVE ASSY PRTY	1				0.24	0.528
240	04811-06100	O RING	1				0	0
240	04816-06100	O RING	1		←		0.001	0.0022
250	67810-38340	DAMPER	1				0.001	0.0022
260	04811-00220	O RING	1				0	0
260	04817-00220	O RING	1		←		0.001	0.0022
270	04810-00140	O RING	1				0	0
270	04817-00140	O RING	1		←		0.001	0.0022
280	04810-00160	O RING	1				0	0
280	04817-00160	O RING	1		←		0.001	0.0022
290	K2561-90300	ASSY SPOOL CONT.VAL.	1				2.5	5.5

TOP LINK

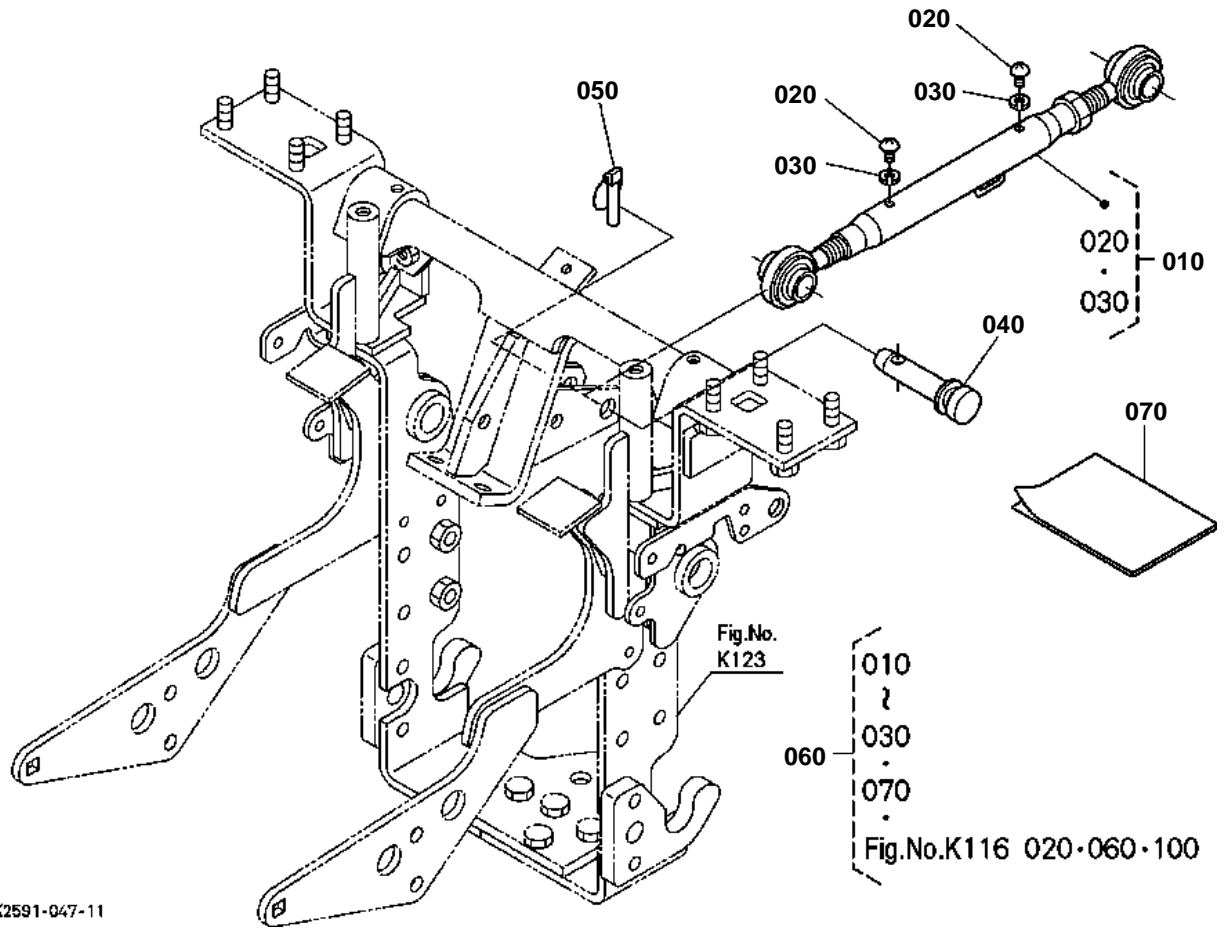

K2591-047-11



# TOP LINK

↔ Interchangeable; ≠ not interchangeable; ← new for old; → old for new

REF.No	Part No.	Description	Q'ty	S.No.	I/C	REMARKS	Weight (kgf)	Weight (lb)
010	K2561-38402	ASSY LINK TOP	1				1.88	4.136
020	03014-50606	SCREW PAN-HEAD	2				0.027	0.0594
030	04512-60060	WASHER SPRING	2				0.001	0.0022
040	K2561-38480	PIN TOP LINK	1				0.232	0.5104
050	K2561-38490	PIN LYNCH	1				0.04	0.088
060	K2561-93840	KIT SERVICE TOP LINK	1				4	8.8
070	K2561-93850	MANUAL	1				0.03	0.066



LOWER LINK

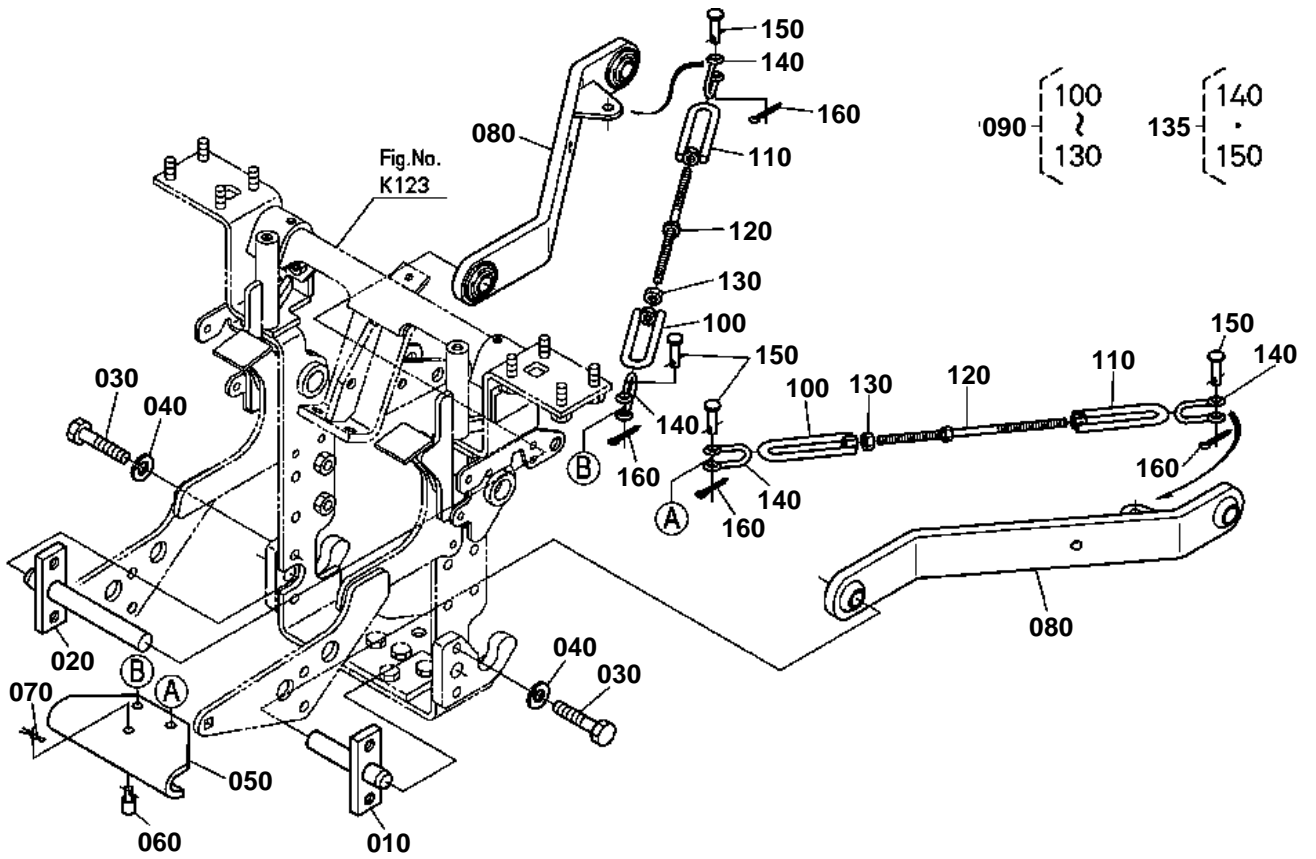

K2591-024-12



LOWER LINK

↔ Interchangeable; ≠ not interchangeable; ← new for old; → old for new

REF.No	Part No.	Description	Q'ty	S.No.	I/C	REMARKS	Weight (kgf)	Weight (lb)
010	K2591-39080	PIN LOWER LINK LH	1				0.73	1.606
020	K2591-39090	PIN LOWER LINK RH	1				0.92	2.024
030	01073-51445	BOLT	4				0.08	0.176
040	75599-33016	WASHER SPRING	4				0.08	0.176
040	04512-60140	WASHER SPRING	4		↔		0.008	0.0176
050	K2561-38170	PLATE CHECK CHAIN	1				11.8	25.96
060	K2561-38180	PIN STOPPER	1				0.04	0.088
070	75599-56004	PIN SNAP	1				0.01	0.022
080	K2561-38210	COMP.LINK LOWER	2				5.12	11.264
090	K2561-38300	ASSY CHAIN CHECK	2				0.55	1.21
100	K2561-38310	NUT CHECK CHAIN RH	2				0.166	0.3652
110	K2561-38320	NUT CHECK CHAIN LH	2				0.18	0.396
120	K2561-38330	BOLT CHECK CHAIN	2				0.21	0.462
130	75599-31015	NUT	2				0.01	0.022
135	K2561-38340	CLEVIS ASSY	4				0.1	0.22
140	K2561-38350	CLEVIS	4			NOT SALE	0	0
150	K2561-38360	PIN JOINT	4			NOT SALE	0	0
160	05511-50425	PIN SPLIT	4				0.003	0.0066

LIFT ROD

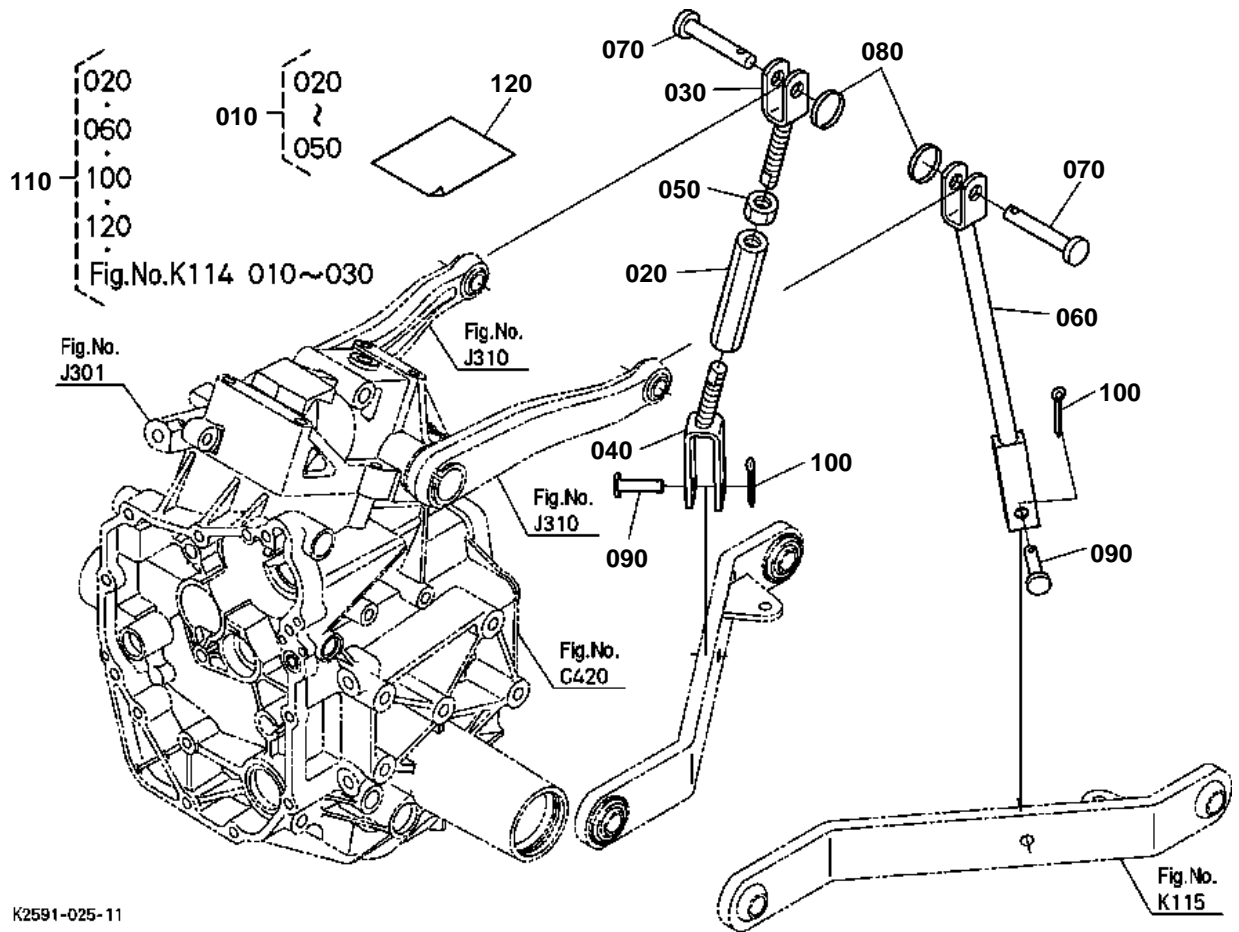

K2591-025-11



# LIFT ROD

↔ Interchangeable; ≠ not interchangeable; ← new for old; → old for new

REF.No	Part No.	Description	Q'ty	S.No.	I/C	REMARKS	Weight (kgf)	Weight (lb)
010	K2561-38220	ASSY ROD LIFT RH	1				1.4	3.08
020	K2561-38250	TURNBUCKLE	1				0.5	1.1
030	K2561-38230	ROD LIFT UPPER RH	1				0.38	0.836
040	K2561-38240	ROD LIFT LOWER RH	1				0.5	1.1
050	75599-31018	NUT	1				0.03	0.066
060	K2561-38270	ROD LIFT LH	1				1.07	2.354
070	05122-51650	PIN JOINT	2				0.09	0.198
080	K5142-72730	RING SNAP	2				0.003	0.0066
090	05122-61245	PIN JOINT	2				0.045	0.099
100	75599-53194	PIN COTTER	2				0.001	0.0022
110	K2561-93840	KIT SERVICE TOP LINK	1				4	8.8
120	K2561-93850	MANUAL	1				0.03	0.066

TOP LINK BRACKET/FENDER BRACKET

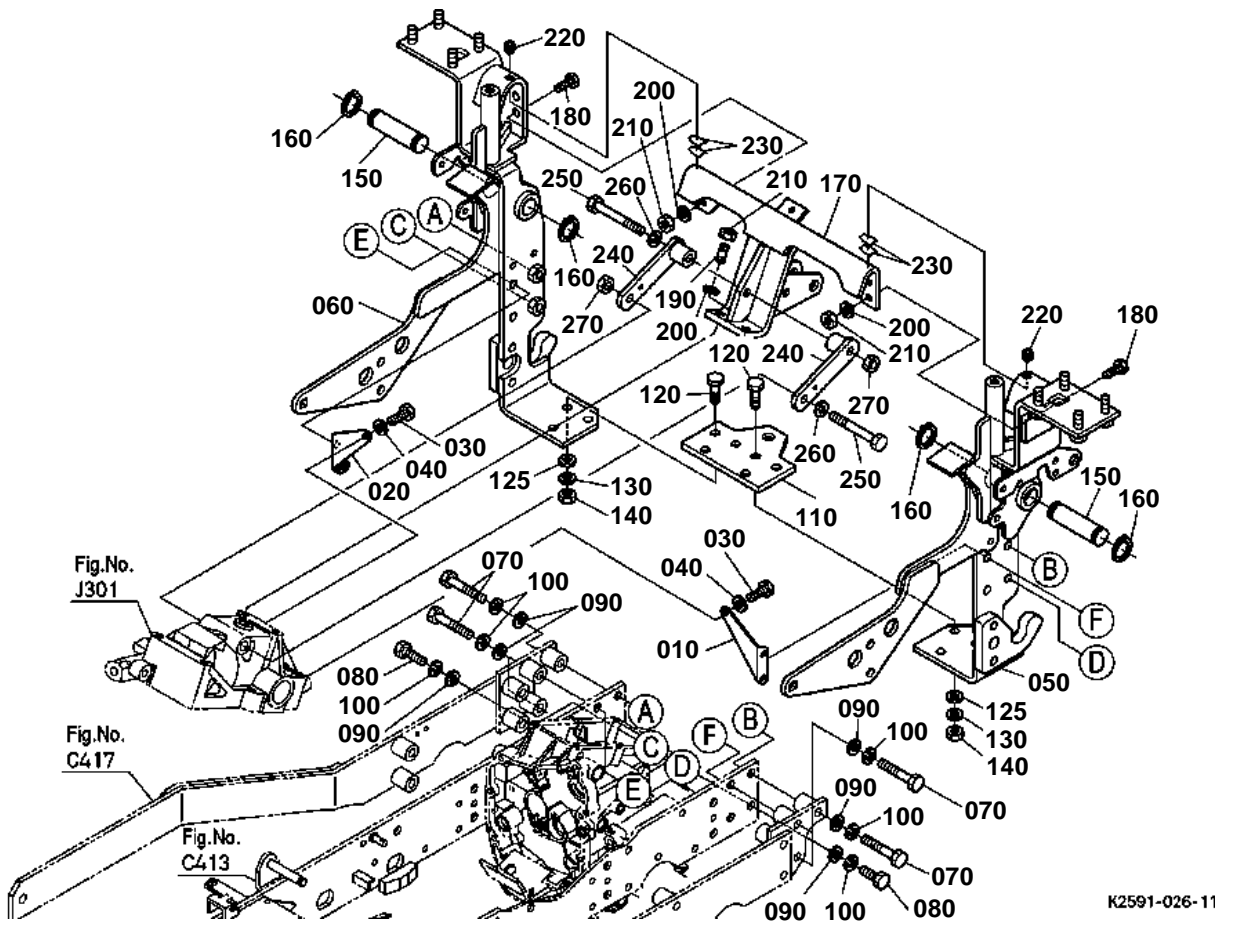

K2591-026-11



TOP LINK BRACKET/FENDER BRACKET

↔ Interchangeable; ≠ not interchangeable; ← new for old; → old for new

REF.No	Part No.	Description	Q'ty	S.No.	I/C	REMARKS	Weight (kgf)	Weight (lb)
010	K2561-21070	SUPPORT REAR LH	1				0	0
020	K2561-21080	SUPPORT REAR RH	1				0	0
030	01053-51225	BOLT	2				0.036	0.0792
040	04512-60120	WASHER SPRING	2				0.005	0.011
050	K2591-39014	BRACKET FENDER LH	1				25.2	55.44
060	K2591-39024	BRACKET FENDER RH	1				25.4	55.88
070	01073-51480	BOLT	6				0.01	0.022
080	01073-51440	BOLT	2				0.069	0.1518
090	75599-32516	WASHER PLAIN	8				0.011	0.0242
100	75599-33016	WASHER SPRING	8				0.08	0.176
100	04512-60140	WASHER SPRING	8		↔		0.008	0.0176
110	K2561-39180	PLATE HITCH	1				2.46	5.412
120	01073-51440	BOLT	6				0.069	0.1518
125	75599-32516	WASHER PLAIN	6				0.011	0.0242
130	75599-33016	WASHER SPRING	6				0.08	0.176
130	04512-60140	WASHER SPRING	6		↔		0.008	0.0176
140	02074-50140	NUT	6				0.021	0.0462
150	K2591-39030	PIN MOUNT	2				0.73	1.606
160	04612-00320	CIR CLIP EXTERNAL	4				0.004	0.0088
170	K2561-39130	STAY FENDER CENTER	1				7.48	16.456
180	01073-51435	BOLT	4				0.063	0.1386
190	01517-51430	STUD	2				0.052	0.1144
200	75599-33016	WASHER SPRING	6				0.08	0.176
200	04512-60140	WASHER SPRING	6		↔		0.008	0.0176
210	02074-50140	NUT	6				0.021	0.0462
220	K2561-39210	SCREW SET	2				0.002	0.0044
230	K2561-39220	SHIM	2			1.2mm	0.005	0.011
230	K2561-39230	SHIM	2			1.5mm	0.006	0.0132
230	K2561-39240	SHIM	2			1.9mm	0.008	0.0176
240	K2591-39140	BRACKET LOWER	2				0.585	1.287
250	01073-51402	BOLT	2			NOT SALE	0	0
250	01173-51402	BOLT 10-125	2		↔		0.13	0.286
260	75599-33016	WASHER SPRING	2				0.08	0.176
260	04512-60140	WASHER SPRING	2		↔		0.008	0.0176
270	02074-50140	NUT	2				0.021	0.0462
270	02174-50140	NUT	2		↔		0.014	0.0308

MOWER REAR LINK RH

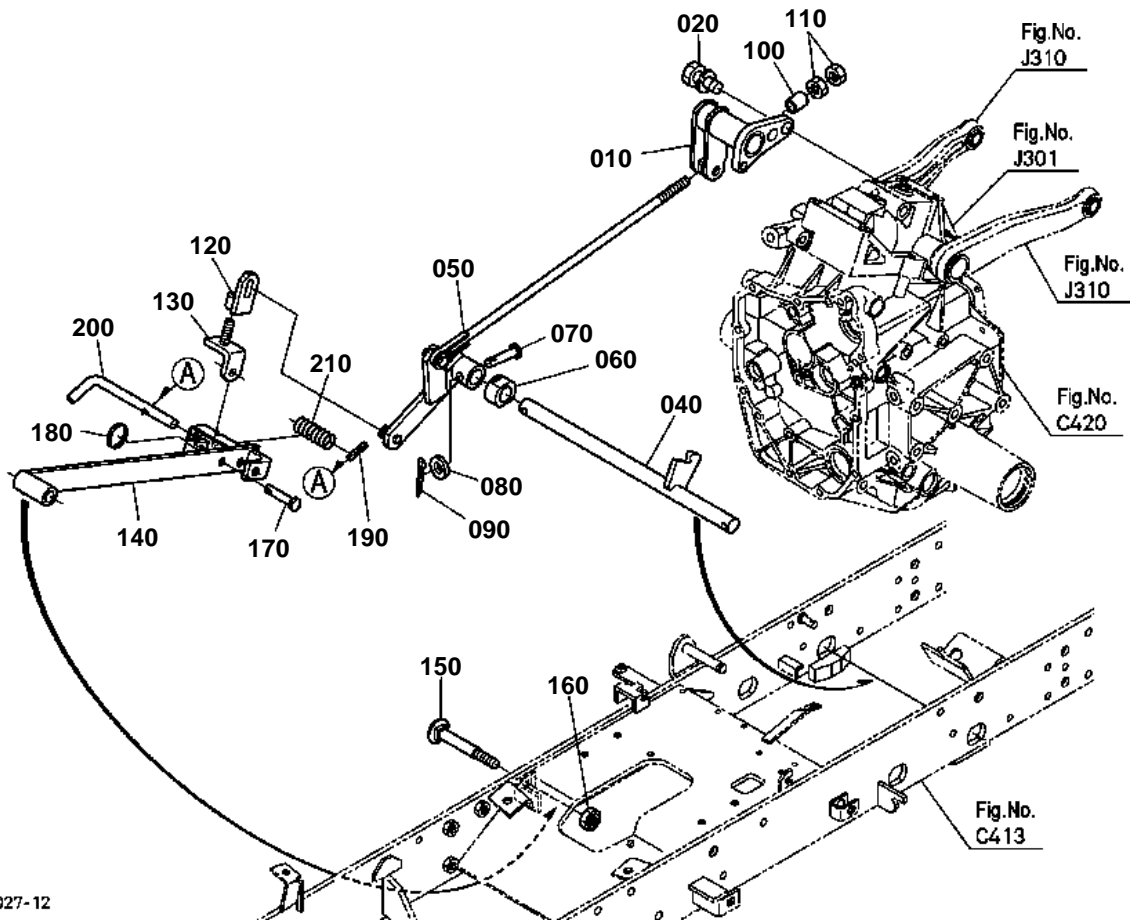

K2591-027-12

## OLD PARTS

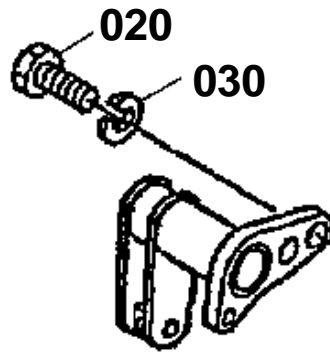

K2591-812-11



**MOWER REAR LINK RH**

↔ Interchangeable; ≠ not interchangeable; ← new for old; → old for new

REF.No	Part No.	Description	Q'ty	S.No.	I/C	REMARKS	Weight (kgf)	Weight (lb)
010	K2561-44114	LINK COMP 3P MOWER	1				1.41	3.102
020	01133-51235	BOLT	2				0.043	0.0946
040	K2561-44250	SHAFT REAR LIFT LINK	1				1.8	3.96
050	K2561-44204	LINK REAR LIFT RH	1				1.57	3.454
060	K2561-43180	BUSH	1				0.099	0.2178
070	75599-51440	PIN CLEVIS	1				0.044	0.0968
080	75599-32014	WASHER PLAIN	1				0.005	0.011
080	0Y401-50070	WASHER PLAIN	1		↔		0.043	0.0946
090	75599-53173	PIN COTTER	1				0.002	0.0044
100	K2561-44180	COLLAR MOWER ADJUST	1				0.023	0.0506
110	02074-50120	NUT	2				0.015	0.033
110	02174-50120	NUT	2		↔		0.01	0.022
120	K2561-44270	LINK LIFT UPPER	1				0.26	0.572
130	K2561-44280	LINK LIFT LOWER	1				0.27	0.594
140	K2561-44310	LINK REAR RH	1				1.89	4.158
150	K1211-91690	BOLT SHORT SQU.NECK	1				0.11	0.242
160	K1211-91930	NUT	1				0.03	0.066
170	75599-51535	PIN CLEVIS	1				0.048	0.1056
180	K5142-72730	RING SNAP	1				0.003	0.0066
190	75599-52532	PIN SPRING	1				0.005	0.011
200	K5651-44650	PIN REAR	1				0.2	0.44
210	K5651-44670	SPRING PIN	1				0.21	0.462

MOWER REAR LINK LH

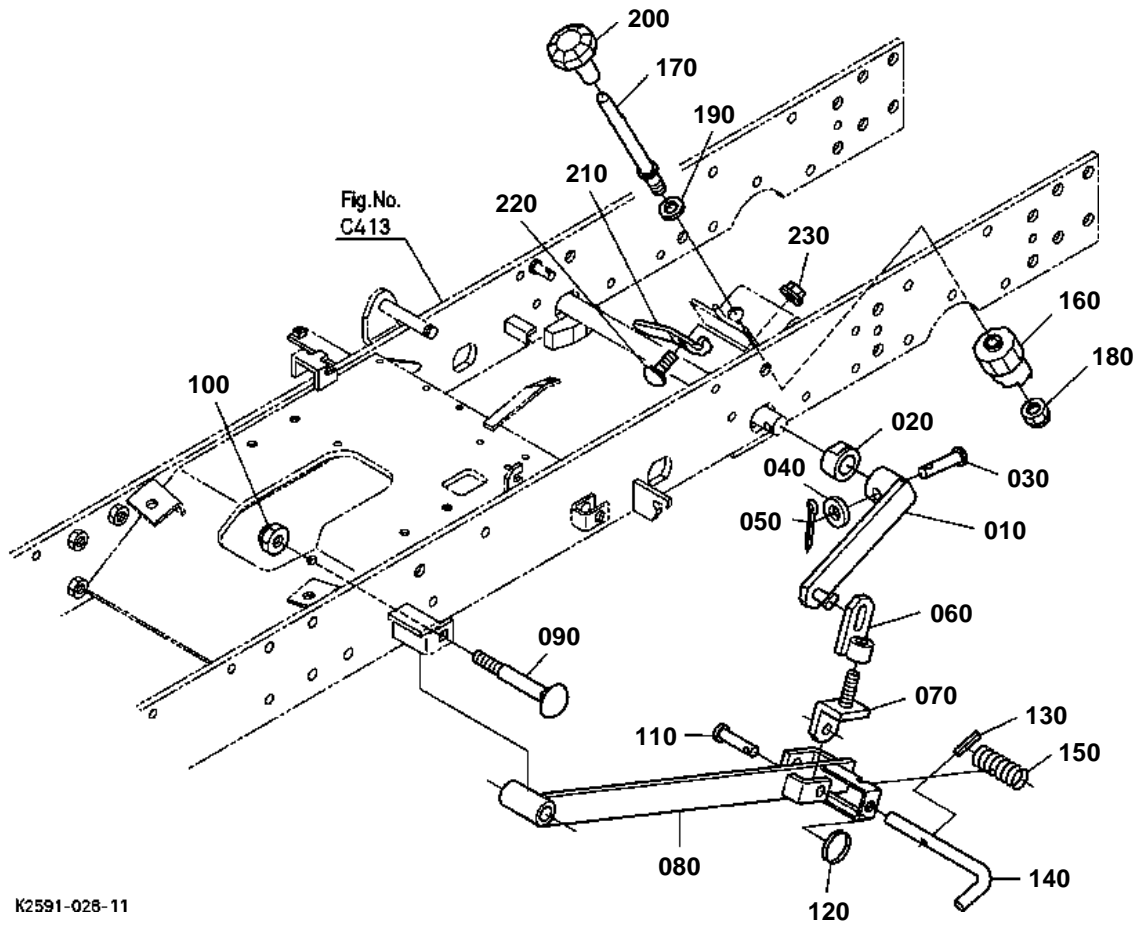

**MOWER REAR LINK LH**

↔ Interchangeable; ≠ not interchangeable; ← new for old; → old for new

REF.No	Part No.	Description	Q'ty	S.No.	I/C	REMARKS	Weight (kgf)	Weight (lb)
010	K2561-44213	LINK REAR LIFT LH	1				0.73	1.606
020	K2561-43180	BUSH	1				0.099	0.2178
030	75599-51440	PIN CLEVIS	1				0.044	0.0968
040	75599-32014	WASHER PLAIN	1				0.005	0.011
040	0Y401-50070	WASHER PLAIN	1		↔		0.043	0.0946
050	75599-53173	PIN COTTER	1				0.002	0.0044
060	K2561-44270	LINK LIFT UPPER	1				0.26	0.572
070	K2561-44280	LINK LIFT LOWER	1				0.27	0.594
080	K2561-44320	LINK REAR LH	1				1.85	4.07
090	K1211-91690	BOLT SHORT SQU.NECK	1				0.11	0.242
100	K1211-91930	NUT	1				0.03	0.066
110	75599-51535	PIN CLEVIS	1				0.048	0.1056
120	K5142-72730	RING SNAP	1				0.003	0.0066
130	75599-52532	PIN SPRING	1				0.005	0.011
140	K5651-44650	PIN REAR	1				0.2	0.44
150	K5651-44670	SPRING PIN	1				0.21	0.462
160	K2561-44410	CAM	1				0.48	1.056
170	K2561-44420	ROD CAM	1				0.152	0.3344
180	K1122-91960	NUT FLANGE	1				0.012	0.0264
190	75599-32015	WASHER PLAIN	1				0.01	0.022
190	04013-60120	WASHER PLAIN	1		↔		0.01	0.022
200	K2561-44430	DIAL CAM	1				0.035	0.077
210	K2561-44440	PLATE RETAINER	1				0.017	0.0374
220	K1122-91320	BOLT SHORT SQU.NECK	1				0.01	0.022
230	02751-50080	NUT FLANGE	1				0.006	0.0132

PTO PROTECTOR

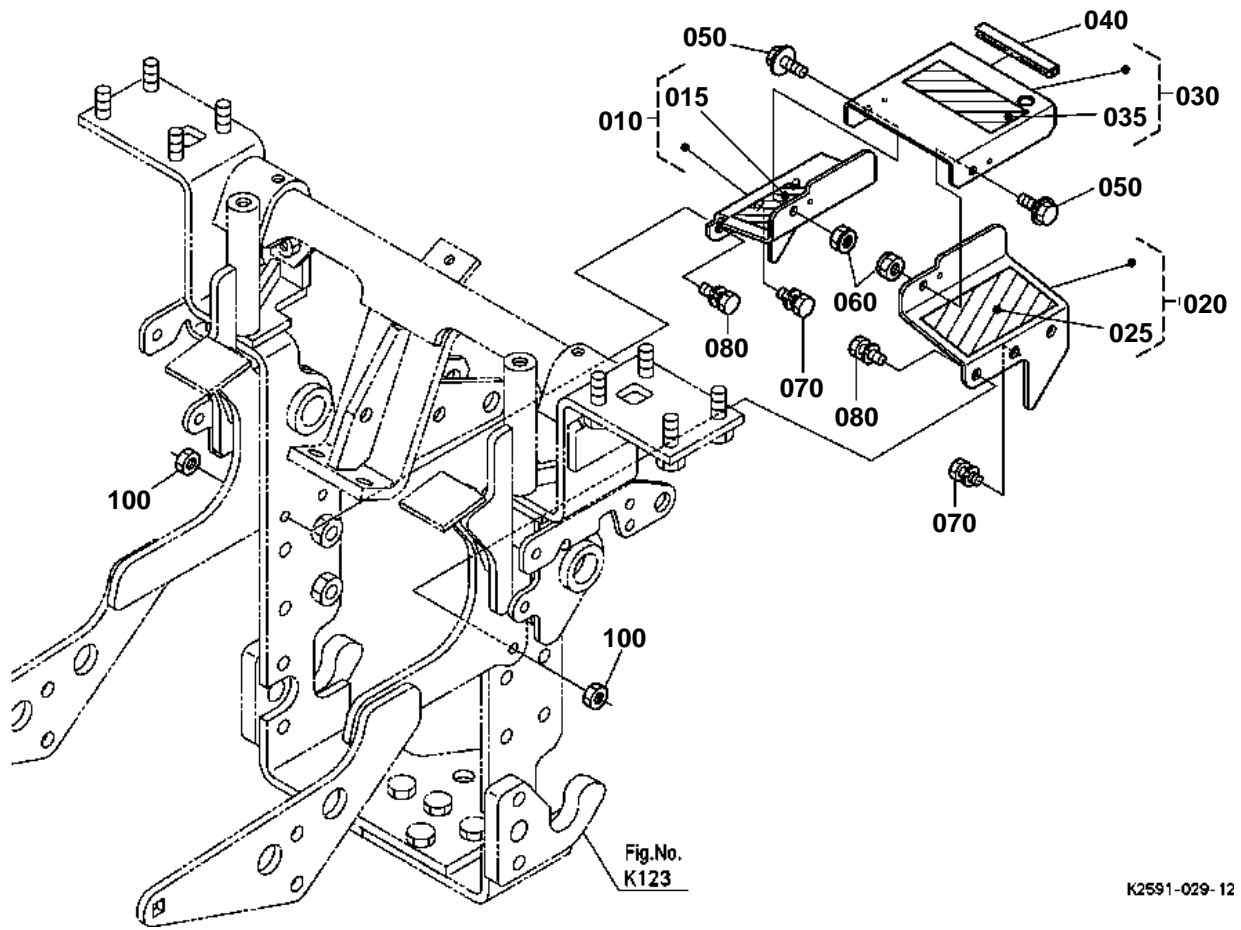

## OLD PARTS

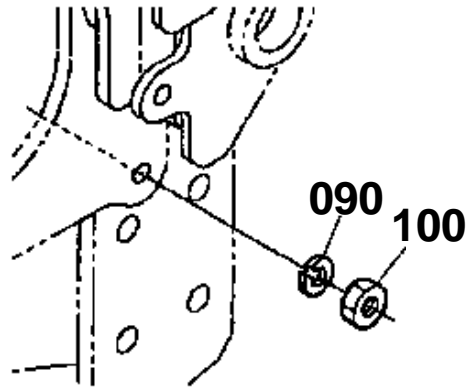

K2591-813-11



PTO PROTECTOR

↔ Interchangeable; ≠ not interchangeable; ← new for old; → old for new

REF.No	Part No.	Description	Q'ty	S.No.	I/C	REMARKS	Weight (kgf)	Weight (lb)
010	K2591-93970	KIT COVER PTO RH	1			ENGLISH	0.55	1.21
010	K2597-93970	KIT COVER PTO RH(F)	1			FRENCH	0	0
015	K2561-65550	LABEL ADJUST CAUTION	1			ENGLISH NOT SALE	0	0
015	K2567-65550	LABEL ADJUST CAUTION	1			FRENCH NOT SALE	0	0
020	K2591-93980	KIT COVER PTO LH	1			ENGLISH	0.55	1.21
020	K2597-93980	KIT COVER PTO LH (F)	1			FRENCH	0	0
025	K2561-65560	LABEL HITCH WARNING	1			ENGLISH NOT SALE	0	0
025	K2567-65560	LABEL HITCH WARNING	1			FRENCH NOT SALE	0	0
030	K2561-93990	KIT COVER PTO UPPER	1			ENGLISH	0.64	1.408
030	K2567-93990	KIT COVER PTO UPPER	1			FRENCH	0	0
035	K2561-65540	LABEL PTO WARNING	1			ENGLISH NOT SALE	0	0
035	K2567-65540	LABEL PTO WARNING	1			FRENCH NOT SALE	0	0
040	K2591-39580	TRIM PTO COVER	1				0	0
050	01754-50820	BOLT FLANGE	2				0.015	0.033
060	02552-50080	NUT LOCK	2				0.005	0.011
070	01133-51030	BOLT	2				0.025	0.055
080	01133-51035	BOLT	2				0.03	0.066
100	02118-50100	NUT	4				0.005	0.011

FRONT GUARD

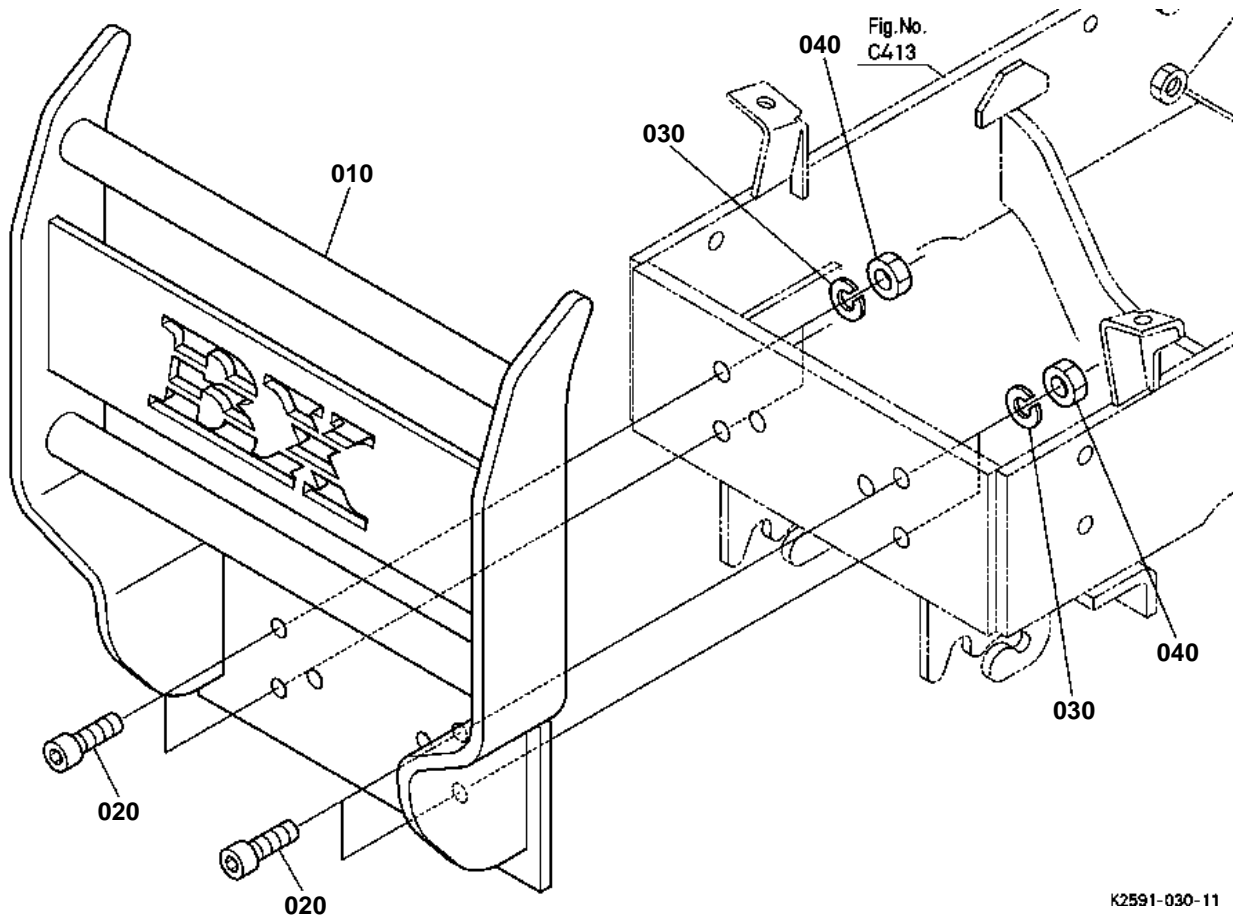

K2591-030-11

OLD PARTS

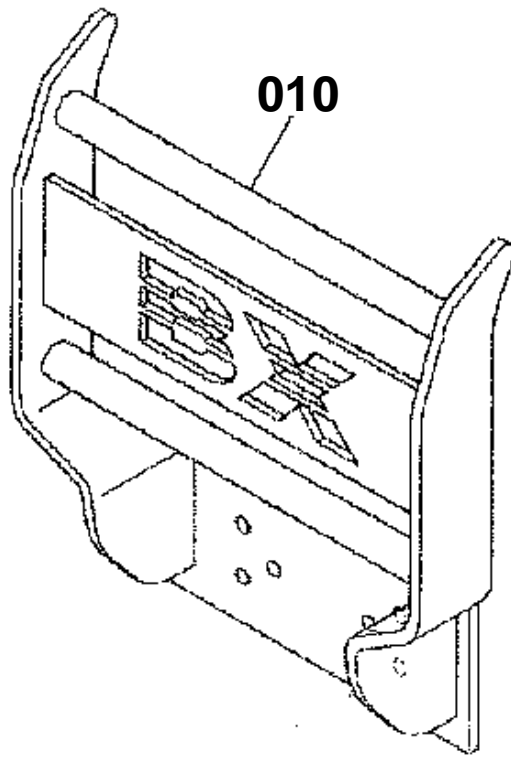

K2591-842-10





# FRONT GUARD

↔ Interchangeable; ≠ not interchangeable; ← new for old; → old for new

REF.No	Part No.	Description	Q'ty	S.No.	I/C	REMARKS	Weight (kgf)	Weight (lb)
010	K2591-21253	GUARD FRONT	1				12	26.4
020	68591-11170	BOLT HEX-SOC-HD	4				0.035	0.077
030	04512-60120	WASHER SPRING	4				0.005	0.011
040	02074-50120	NUT	4				0.015	0.033
040	02174-50120	NUT	4		↔		0.01	0.022

FRONT GLILLE SUPPORT

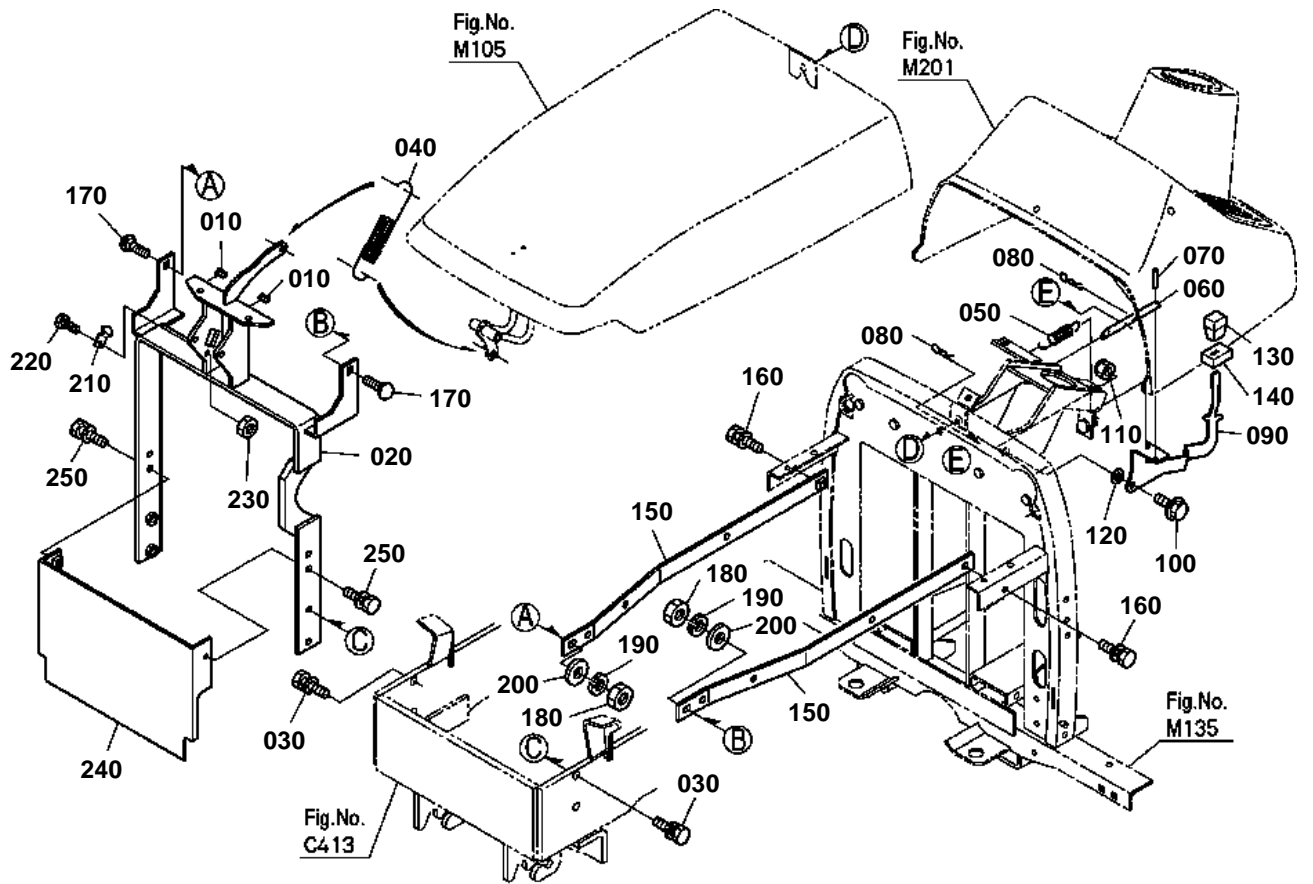

K2591-031-14



# FRONT GLILLE SUPPORT

↔ Interchangeable; ≠ not interchangeable; ← new for old; → old for new

REF.No	Part No.	Description	Q'ty	S.No.	I/C	REMARKS	Weight (kgf)	Weight (lb)
010	K2561-54220	CUSHION	2				0.005	0.011
020	K2571-54230	POST BONNET	1				3.73	8.206
030	01133-51030	BOLT	4				0.025	0.055
040	K2561-54250	SPRING	1				0.05	0.11
050	K2561-54260	SPRING	1				0.009	0.0198
060	K2571-54270	ROD BONNET OPEN	1				0.01	0.022
070	05411-00325	PIN SPRING	1				0.001	0.0022
080	75599-56004	PIN SNAP	2				0.01	0.022
090	K2571-54300	LEVER BONNET OPEN	1				0.19	0.418
100	01754-50825	BOLT FLANGE	1				0.01	0.022
110	02552-50080	NUT LOCK	1				0.005	0.011
120	04013-60080	WASHER PLAIN	1				0.002	0.0044
130	31355-82290	GRIP LEVER	1				0.015	0.033
140	K2571-54280	SPONGE	1				0.001	0.0022
150	K2561-54290	SUPPORT BONNET STAY	2				0.424	0.9328
160	01123-50820	BOLT	2				0.011	0.0242
170	K1122-91320	BOLT SHORT SQU.NECK	2				0.01	0.022
180	02114-50080	NUT	2				0.005	0.011
190	04512-60080	WASHER SPRING	2				0.002	0.0044
200	04013-60080	WASHER PLAIN	2				0.002	0.0044
210	K2561-54430	STOPPER BONNET	1				0.006	0.0132
220	01023-50616	BOLT	1				0.005	0.011
230	02014-50060	NUT	1				0.002	0.0044
240	K2561-54450	COVER FLYWHEEL	1				0	0
250	01123-50820	BOLT	2				0.011	0.0242

BONNET

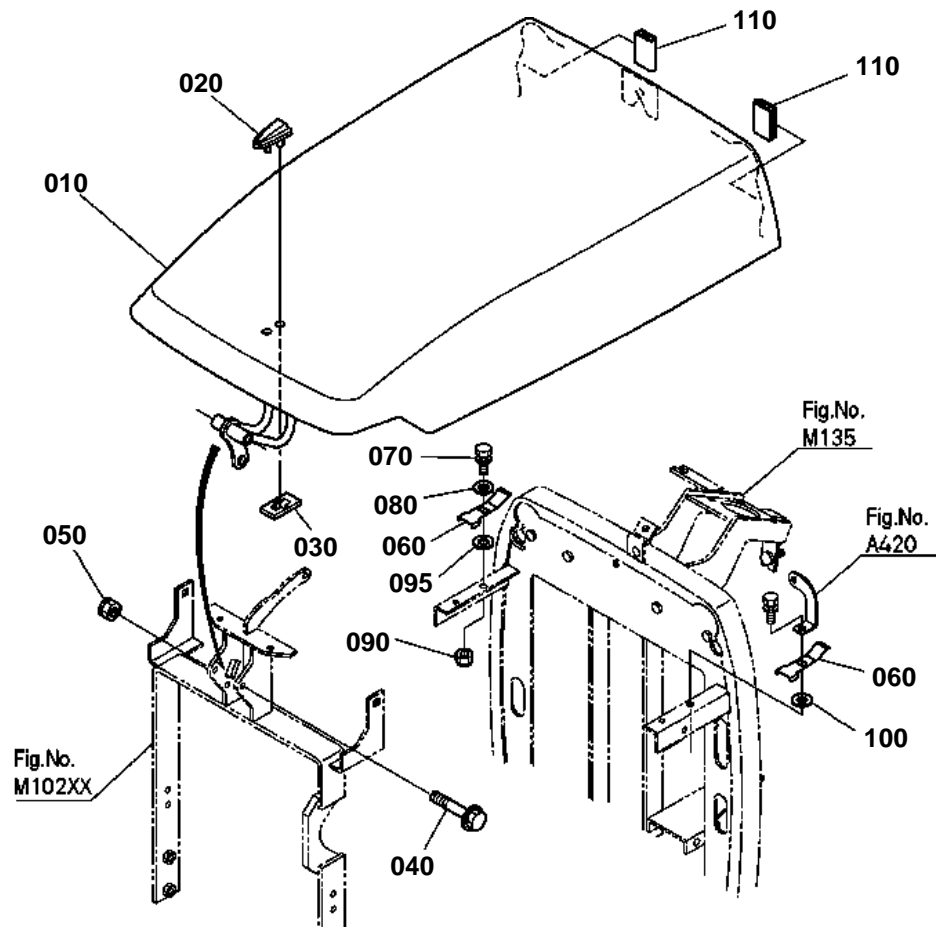

K2591-110-10

# OLD PARTS

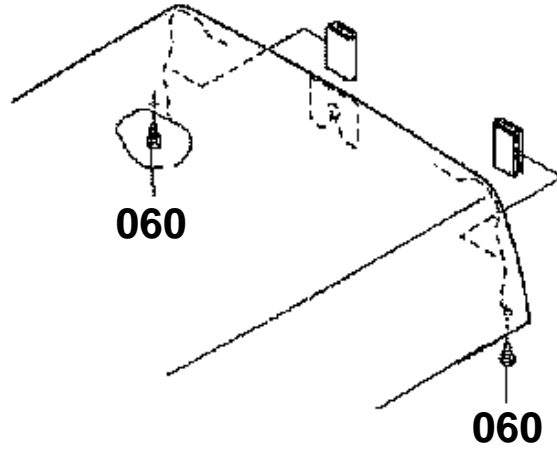

K2591-838-11

**BONNET**

↔ Interchangeable; ≠ not interchangeable; ← new for old; → old for new

REF.No	Part No.	Description	Q'ty	S.No.	I/C	REMARKS	Weight (kgf)	Weight (lb)
010	K2561-54110	COMP BONNET UPPER	1				6.2	13.64
020	K2561-54130	MARK	1				0.008	0.0176
030	K2561-54170	NUT	1				0.001	0.0022
040	01754-50870	BOLT FLANGE	1				0.028	0.0616
050	K5112-72840	NUT LOCK	1				0.005	0.011
060	K2571-54372	DAMPER BONNET	2				0.008	0.0176
070	01123-50820	BOLT	1				0.011	0.0242
080	04013-60080	WASHER PLAIN	1				0.002	0.0044
090	02751-50080	NUT FLANGE	1				0.006	0.0132
100	04012-50080	WASHER PLAIN	2				0.001	0.0022
110	K2561-54380	TRIM SASH	2				0.005	0.011

BONNET SIDE

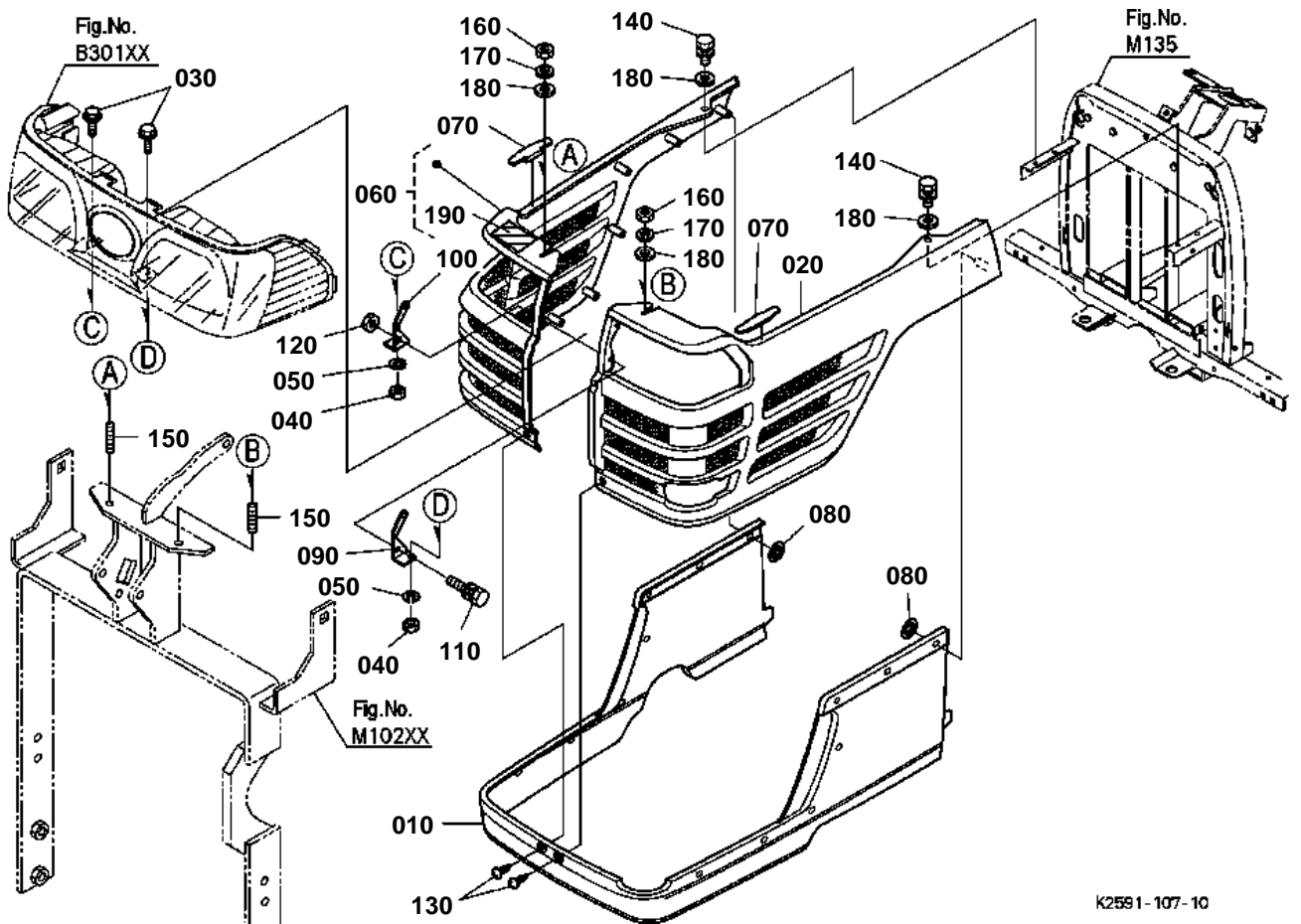

K2591-107-10

**BONNET SIDE**

↔ Interchangeable; ≠ not interchangeable; ← new for old; → old for new

REF.No	Part No.	Description	Q'ty	S.No.	I/C	REMARKS	Weight (kgf)	Weight (lb)
010	K2561-54140	BONNET UNDER	1				4	8.8
020	K2561-54150	COVER LH	1				0.83	1.826
030	01754-50616	BOLT FLANGE	2				0.006	0.0132
040	02014-50060	NUT	2				0.002	0.0044
050	04512-60060	WASHER SPRING	2				0.001	0.0022
060	K2561-95410	KIT COVER BONNET RH	1				0.5	1.1
070	K2561-54200	CUSHION	2				0.004	0.0088
080	K2561-54410	NUT	14				0.001	0.0022
090	K2571-54350	STAY HEAD RIGHT LH	1				0.04	0.088
100	K2571-54360	STAY HEAD RIGHT RH	1				0.04	0.088
110	01025-50655	BOLT	2				0.015	0.033
120	02751-50060	NUT FLANGE	2				0.005	0.011
130	K2561-54180	SCREW TAPPING	2				0.005	0.011
140	01023-50620	BOLT	2				0.006	0.0132
150	01513-50625	STUD	2				0.007	0.0154
160	02014-50060	NUT	2				0.002	0.0044
170	04512-60060	WASHER SPRING	2				0.001	0.0022
180	04015-60060	WASHER PLAIN	4				0.005	0.011
190	K2561-65420	LABEL HOT CAUTION	1			NOT SALE	0	0



CENTER PILLAR

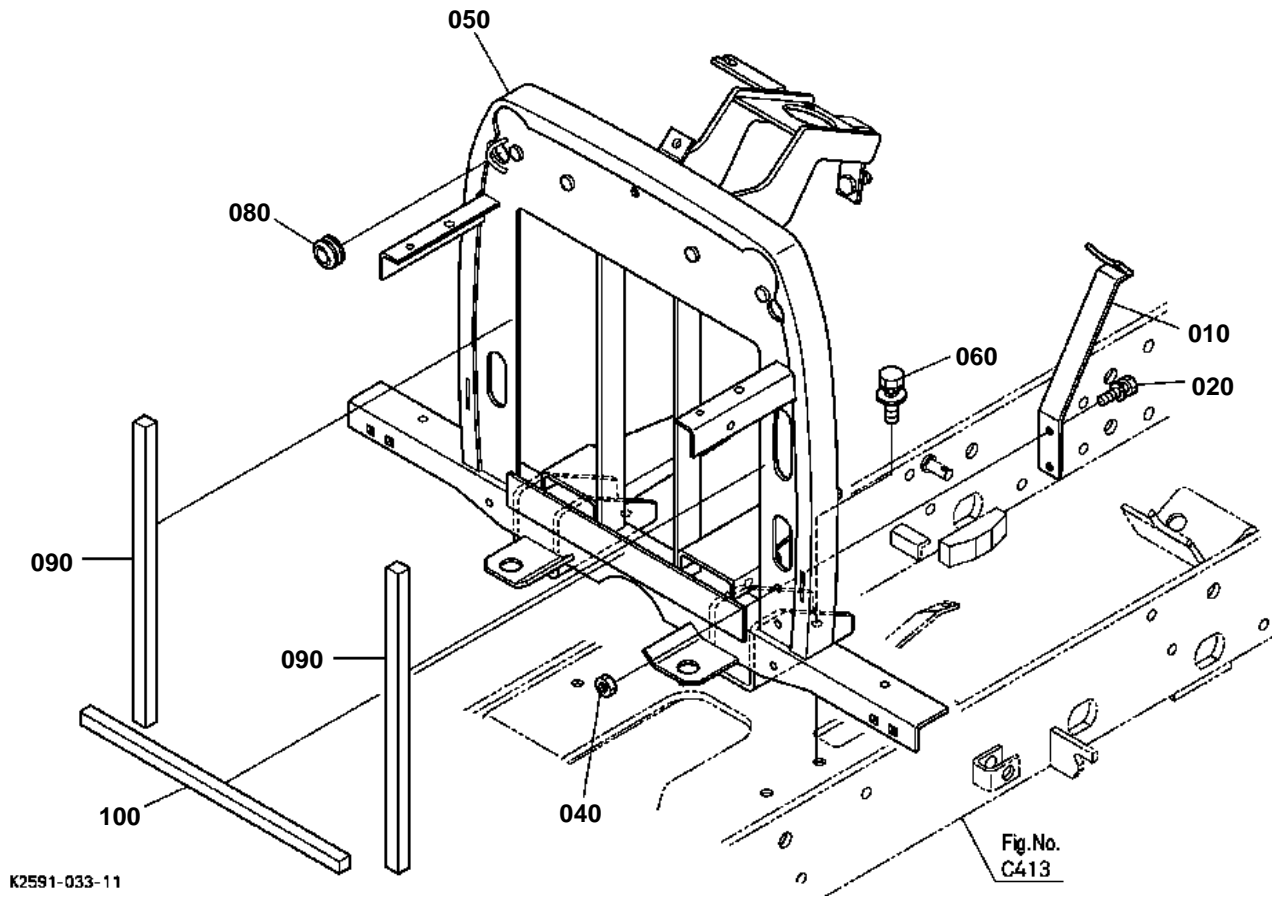

# OLD PARTS

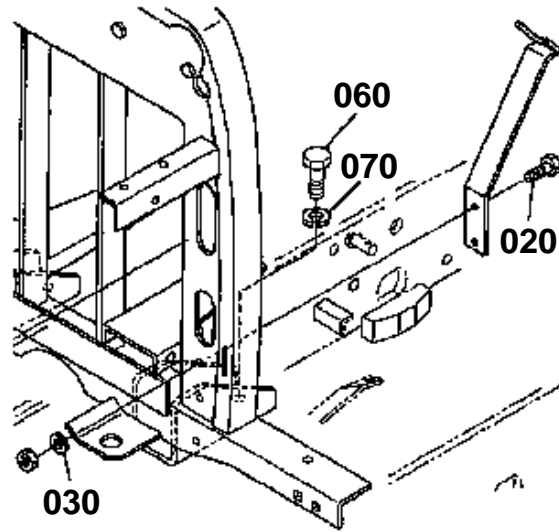

K2591-843-10



# CENTER PILLAR

↔ Interchangeable; ≠ not interchangeable; ← new for old; → old for new

REF.No	Part No.	Description	Q'ty	S.No.	I/C	REMARKS	Weight (kgf)	Weight (lb)
010	K2561-41690	STAY HOSE	1				0.328	0.7216
020	01123-50820	BOLT	2				0.011	0.0242
040	02114-50080	NUT	2				0.005	0.011
050	K2571-57210	PILLER CENTER	1				0	0
060	K2571-57220	BOLT	4				0	0
080	K2561-57240	GROMMET WIRE	1				0.003	0.0066
090	K2561-57250	SPONGE	2				0.003	0.0066
100	K2561-57350	SPONGE LOWER	1				0.006	0.0132

PANEL FRAME

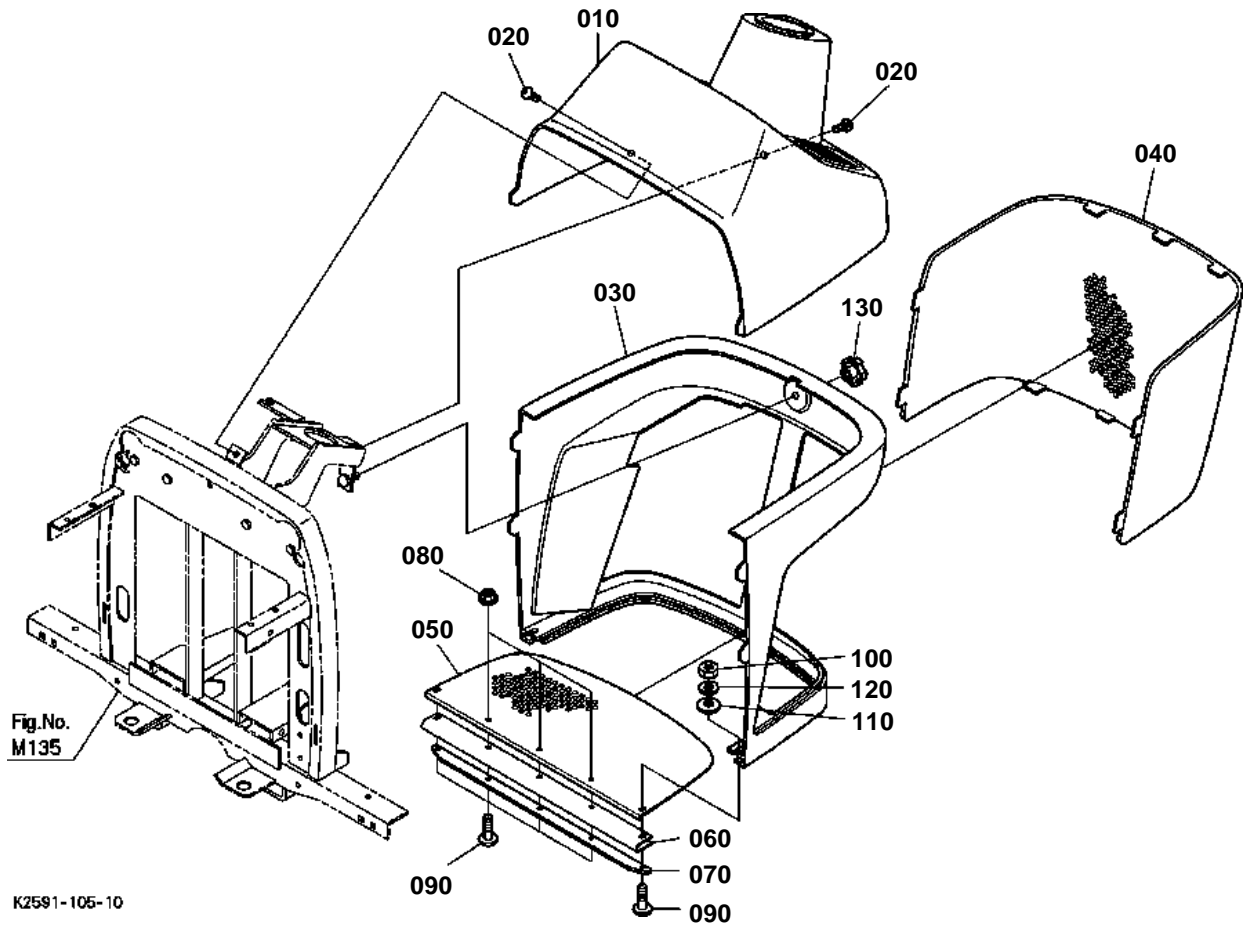



PANEL FRAME

↔ Interchangeable; ≠ not interchangeable; ← new for old; → old for new

REF.No	Part No.	Description	Q'ty	S.No.	I/C	REMARKS	Weight (kgf)	Weight (lb)
010	K2561-57110	PANEL U.	1				1.45	3.19
020	K2561-57160	SCREW CR-REC-BD-HD	2				0.01	0.022
030	K2561-57130	PANEL D.	1				2.215	4.873
040	K2561-57140	PLATE AIR SCREEN U.	1				0.56	1.232
050	K2561-57150	PLATE AIR SCREEN D.	1				0.31	0.682
060	K2561-57180	PLATE RUBBER DUST	1				0.03	0.066
070	K2561-57190	PLATE RUBBER HOLD	1				0.166	0.3652
080	02751-50060	NUT FLANGE	3				0.005	0.011
090	03017-50616	SCREW CR-REC-BD-HD	5				0.005	0.011
100	02014-50060	NUT	2				0.002	0.0044
110	75599-32011	WASHER PLAIN	2				0.001	0.0022
110	04013-60060	WASHER PLAIN	2		↔		0.001	0.0022
120	75599-33011	WASHER SPRING	2				0.002	0.0044
120	04512-60060	WASHER SPRING	2		↔		0.001	0.0022
130	K2561-57170	NUT KNOB	1				0.015	0.033

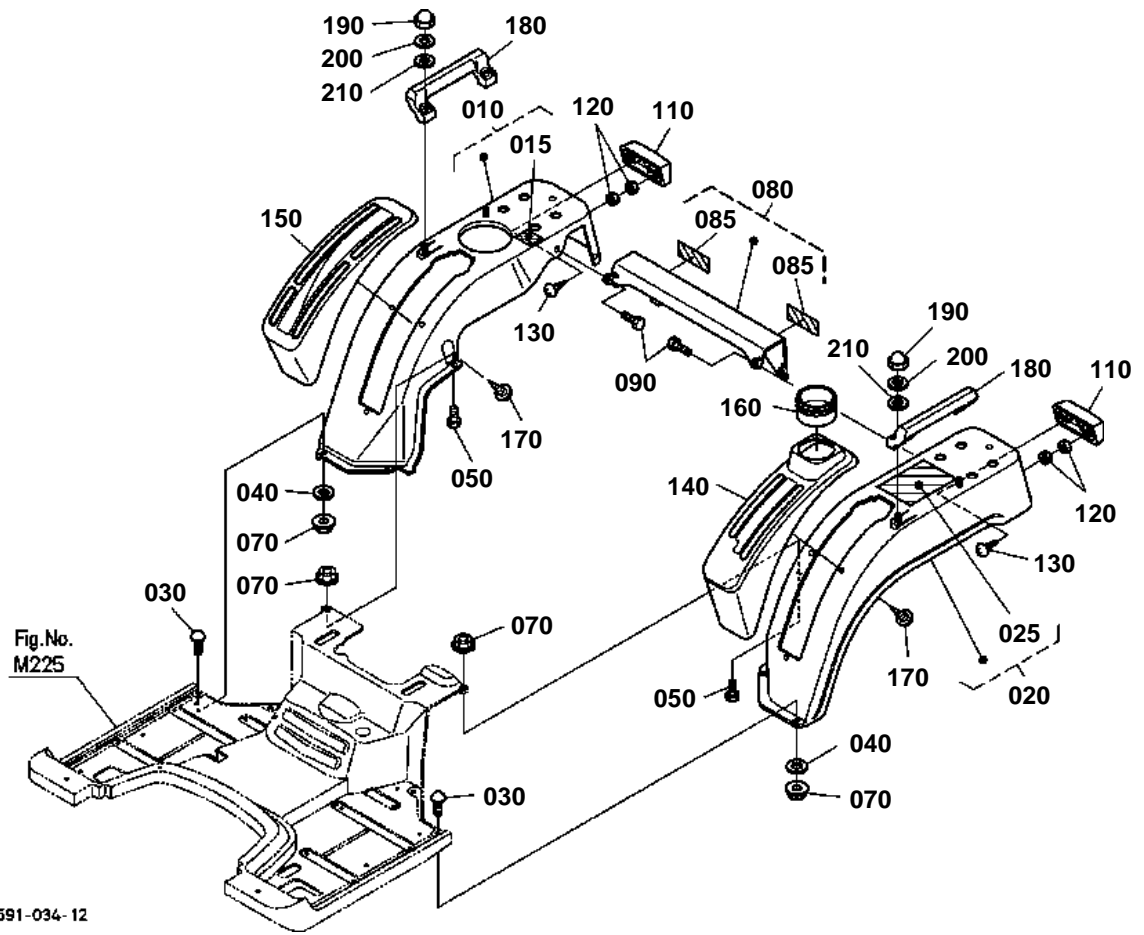

# OLD PARTS

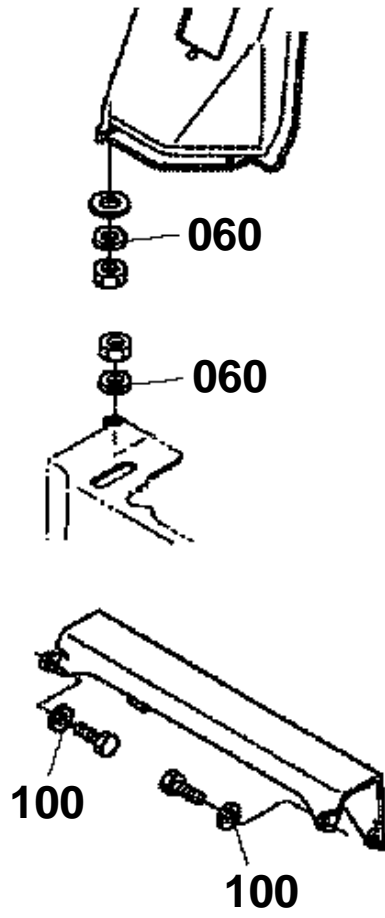

K2591-833-11



FENDER

↔ Interchangeable; ≠ not interchangeable; ← new for old; → old for new

REF.No	Part No.	Description	Q'ty	S.No.	I/C	REMARKS	Weight (kgf)	Weight (lb)
010	K2561-95520	KIT FENDER RH	1				1.5	3.3
015	K2561-65490	LABEL FUEL FILTER	1			NOT SALE	0	0
020	K2561-95532	KIT FENDER LH	1			ENGLISH	2.8	6.16
020	K2567-95532	KIT FENDER LH	1			FRENCH	2.815	6.193
025	K2561-65482	LABEL SAFETY	1			ENGLISH NOT SALE	0	0
025	K2567-65482	LABEL SAFETY	1			FRENCH NOT SALE	0	0
030	K1122-91320	BOLT SHORT SQU.NECK	4				0.01	0.022
040	75599-32113	WASHER PLAIN	4				0.01	0.022
040	04015-50100	WASHER PLAIN	4		↔		0.016	0.0352
050	01153-50812	BOLT	2				0.008	0.0176
070	02751-50080	NUT FLANGE	6				0.006	0.0132
080	K2591-95540	KIT COVER FENDER R	1			ENGLISH	0.91	2.002
080	K2597-95540	KIT COVER FENDER R	1			FRENCH	0	0
085	K2561-65522	LABEL SPACE WARNING	2			ENGLISH NOT SALE	0	0
085	K2567-65520	LABEL SPACE WARNING	2			FRENCH NOT SALE	0	0
090	01123-50820	BOLT	4				0.011	0.0242
110	K2561-55110	BASE TAIL LAMP	2				0.053	0.1166
120	02054-50040	NUT	8				0.001	0.0022
130	K1122-55280	SCREW TAPPING	4				0.002	0.0044
140	K2561-55210	GUIDE LEVER LH	1				0.26	0.572
150	K2561-55220	GUIDE LEVER RH	1				0.375	0.825
160	K2561-55270	HOLDER CUP	1				0.09	0.198
170	K1122-55280	SCREW TAPPING	6				0.002	0.0044
180	K2561-55280	HANDRAIL	2				0.229	0.5038
190	K2561-55290	NUT CAP	4				0.013	0.0286
200	04512-60100	WASHER SPRING	4				0.002	0.0044
210	75599-32013	WASHER PLAIN	4				0.03	0.066
210	04011-50100	WASHER PLAIN	4		↔		0.002	0.0044



SEAT SUPPORT

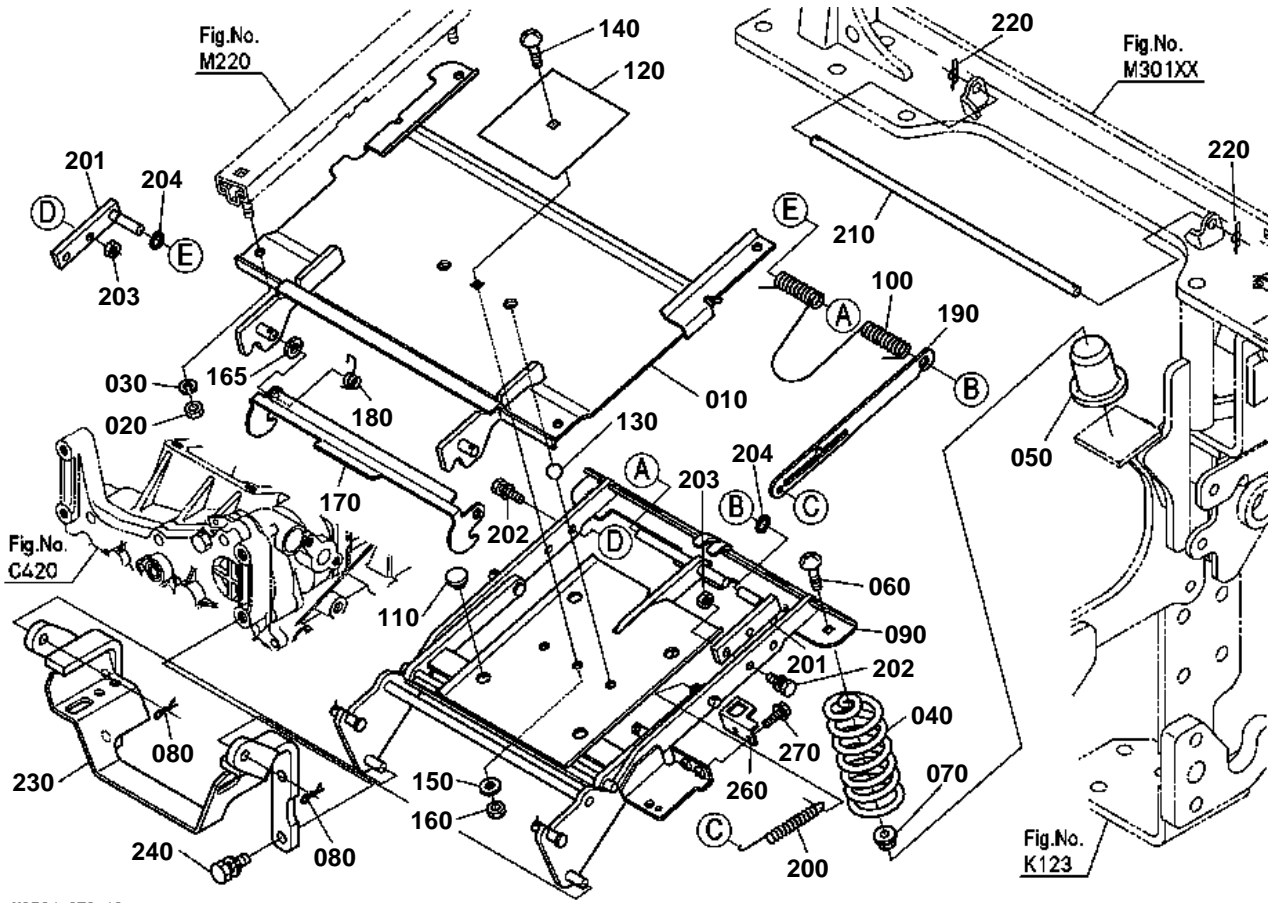

K2591-073-10

# OLD PARTS

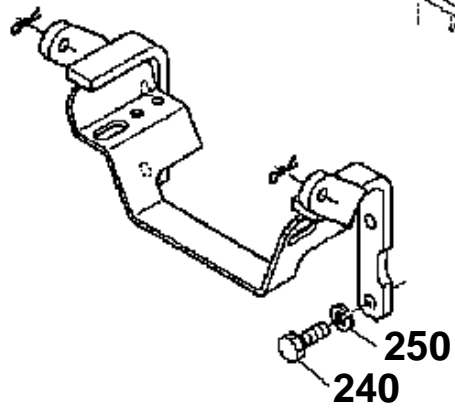
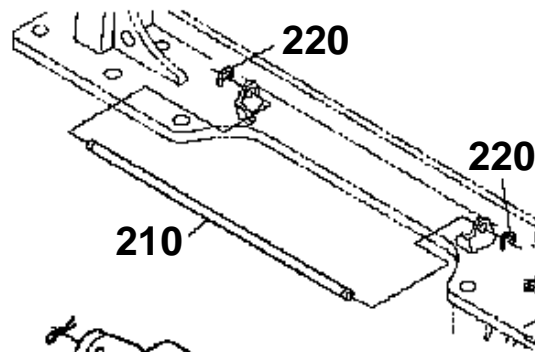
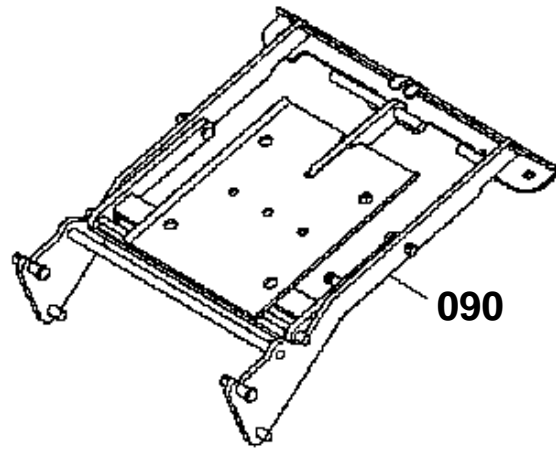

K2591-823-11

**SEAT SUPPORT**

↔ Interchangeable; ≠ not interchangeable; ← new for old; → old for new

REF.No	Part No.	Description	Q'ty	S.No.	I/C	REMARKS	Weight (kgf)	Weight (lb)
010	K2591-56745	STAY LOWER RAIL	1				3.9	8.58
020	75599-31012	NUT	4				0.007	0.0154
030	75599-33012	WASHER SPRING	4				0.002	0.0044
030	04512-60080	WASHER SPRING	4		↔		0.002	0.0044
040	K2561-56780	SPRING SEAT	2				0.27	0.594
050	K2561-56790	CAP SPRING	2				0.075	0.165
060	K1122-91320	BOLT SHORT SQU.NECK	2				0.01	0.022
070	02751-50080	NUT FLANGE	2				0.006	0.0132
080	75599-56004	PIN SNAP	2				0.01	0.022
090	K2591-56617	SUPPORT SEAT	1				4.35	9.57
100	K2591-56642	SPRING ASSIST	1				0.14	0.308
110	K2591-56670	SPACER TURN SEAT	4				0.004	0.0088
120	K2591-56682	SPRING	1				0.11	0.242
130	07715-01607	BALL	2				0.005	0.011
140	01611-50830	BOLT CUP-SQ-NK	1				0	0
150	75599-32112	WASHER PLAIN	1				0.001	0.0022
150	04015-60080	WASHER PLAIN	1				0.01	0.022
160	K5112-72840	NUT LOCK	1				0.005	0.011
165	04011-50100	WASHER PLAIN	1				0.002	0.0044
170	K2591-56620	HOOK SEAT	1				0.22	0.484
180	K2591-56632	SPRING SEAT HOOK	1				0.02	0.044
190	K2591-56662	PLATE STOPPER	1				0.1	0.22
200	K2591-56652	SPRING	1				0.01	0.022
201	K2591-56712	PLATE SPRING ROD	2				0	0
202	01123-50825	BOLT	4				0.013	0.0286
203	02114-50080	NUT	4				0.005	0.011
204	04613-50080	CIR CLIP EXTERNAL	1				0.001	0.0022
210	K2591-56693	ROD SEAT HOOK	1				0.2	0.44
220	K1211-91130	RUE RING COTTER	2				0.01	0.022
230	K2561-56730	STAY SEAT RAIL FRONT	1				0	0
240	01123-51030	BOLT	4				0.025	0.055
260	K2591-56840	STAY SWITCH	1				0	0
270	01754-50616	BOLT FLANGE	2				0.006	0.0132

SEAT

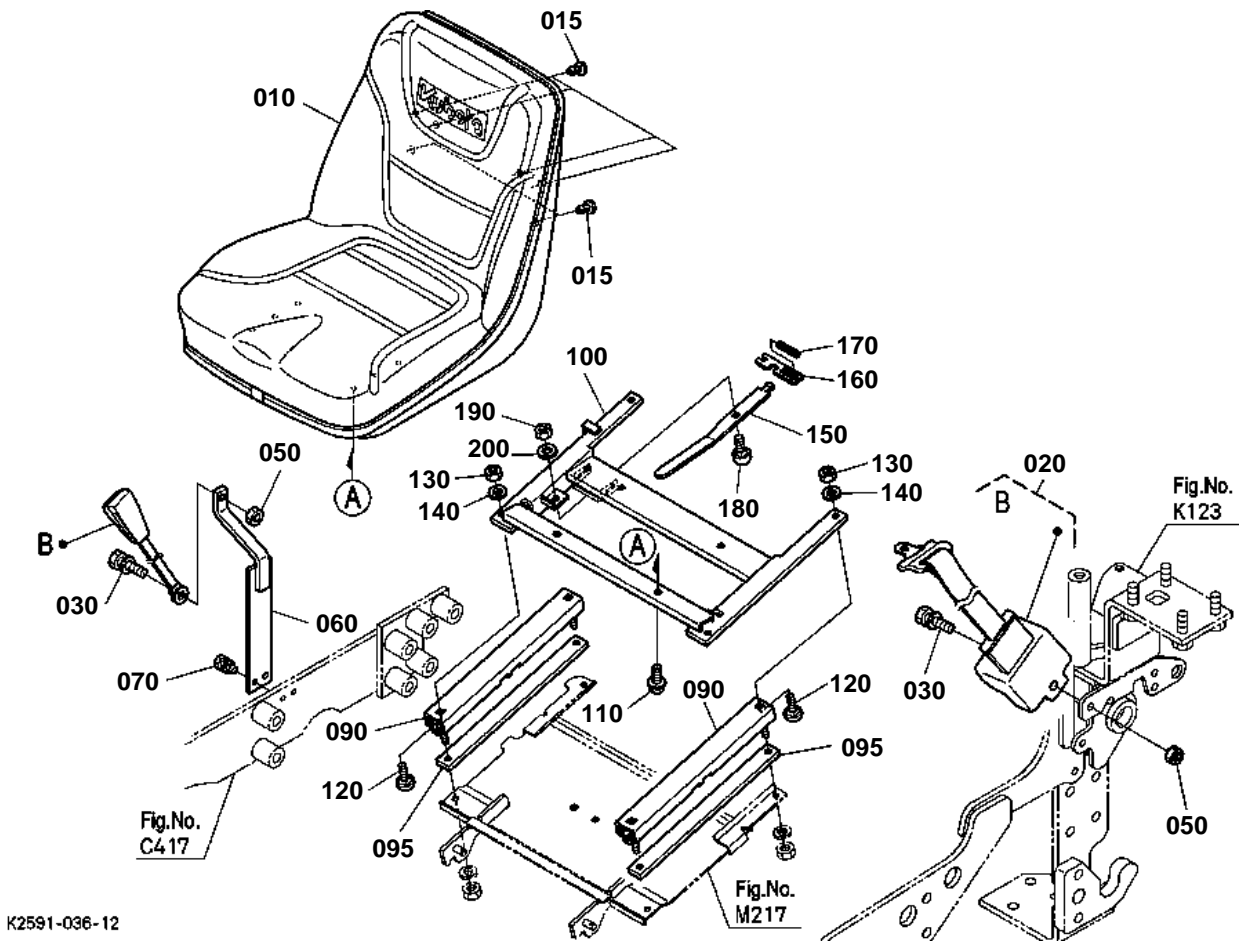

# OLD PARTS

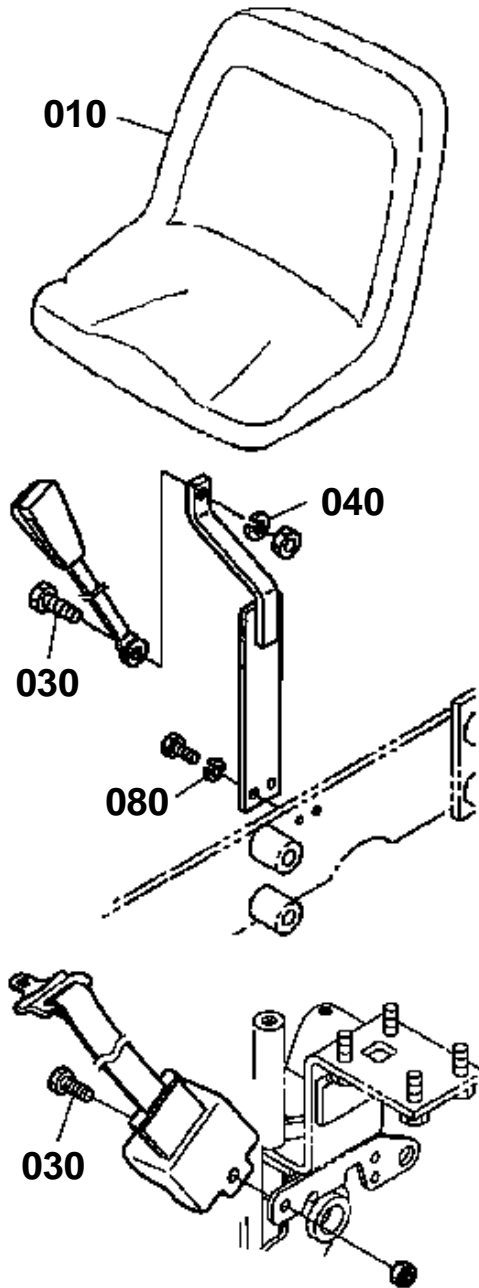

K2591-834-11



SEAT

↔ Interchangeable; ≠ not interchangeable; ← new for old; → old for new

REF.No	Part No.	Description	Q'ty	S.No.	I/C	REMARKS	Weight (kgf)	Weight (lb)
010	K2571-56110	SEAT	1				9	19.8
015	K2571-56120	PLUG	6				0	0
020	K2561-56850	ASSY BELT SEAT	1				0.81	1.782
030	01133-51030	BOLT	2				0.025	0.055
050	02018-50100	NUT	2				0.011	0.0242
050	02118-50100	NUT	2		↔		0.005	0.011
060	K2591-56860	STAY SEAT BELT	1				0	0
070	01123-50820	BOLT	2				0.011	0.0242
090	K2561-56710	RAIL SEAT	2				0.665	1.463
095	K2591-56880	PLATE SEAT RAIL	2				0	0
100	K2561-56758	STAY UPPER RAIL	1				1.47	3.234
110	0Y171-50508	BOLT FLANGE	4				0.015	0.033
120	K1122-91320	BOLT SHORT SQU.NECK	4				0.01	0.022
130	02054-50080	NUT	4				0.005	0.011
130	02114-50080	NUT	4		↔		0.005	0.011
140	75599-33012	WASHER SPRING	4				0.002	0.0044
140	04512-60080	WASHER SPRING	4		↔		0.002	0.0044
150	K2561-56810	LEVER ADJUSTER	1				0	0
160	K2561-56830	PLATE STOPPER	1				0.023	0.0506
170	K2561-56820	SPRING ADJUST	1				0.003	0.0066
180	K1122-91320	BOLT SHORT SQU.NECK	1				0.01	0.022
190	K5112-72840	NUT LOCK	1				0.005	0.011
200	75599-32112	WASHER PLAIN	1				0.001	0.0022
200	04015-60080	WASHER PLAIN	1		↔		0.01	0.022

STEP

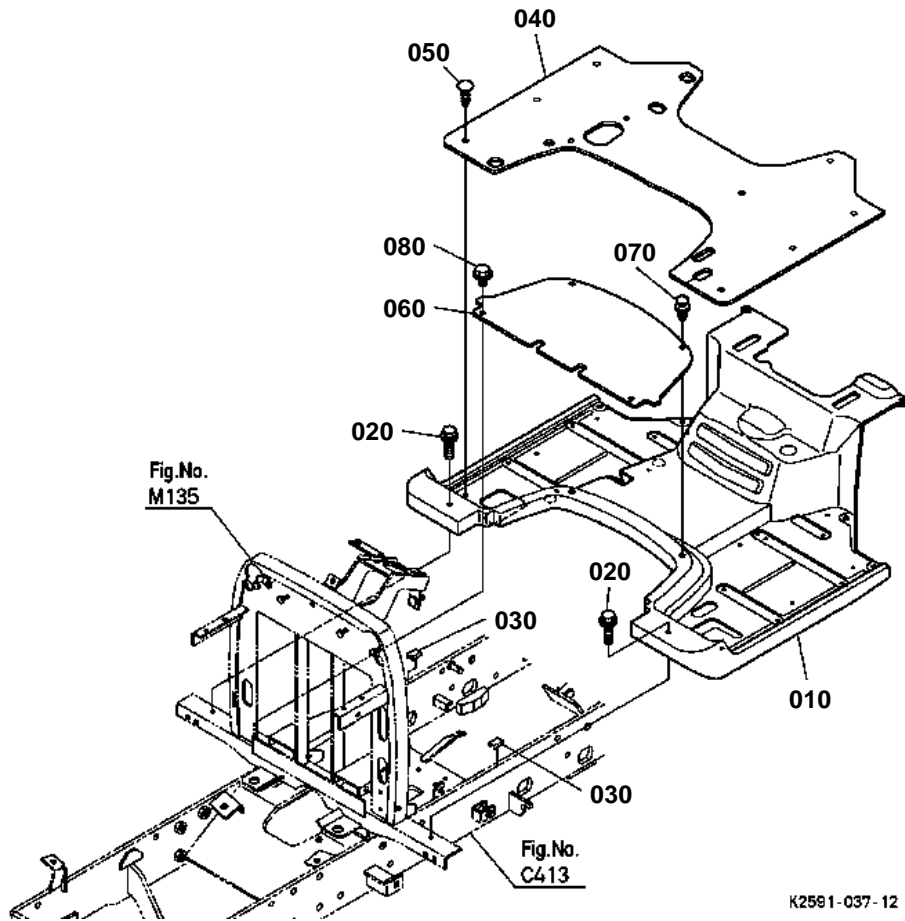

K2581-037-12

# OLD PARTS

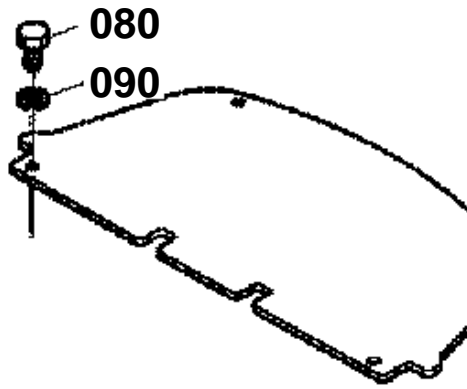

K2591-817-11



**STEP**

↔ Interchangeable; ≠ not interchangeable; ← new for old; → old for new

REF.No	Part No.	Description	Q'ty	S.No.	I/C	REMARKS	Weight (kgf)	Weight (lb)
010	K2561-55150	STEP	1				8	17.6
020	01754-50820	BOLT FLANGE	2				0.015	0.033
030	K2561-55180	TRIM FRAME	2				0.007	0.0154
040	K2561-55310	MAT STEP	1				1.05	2.31
050	K1211-84560	PUSH RIVET	11				0.002	0.0044
060	K2561-57310	PLATE STEP	1				0.6	1.32
070	K2561-57320	RIVET SCREW	2				0.001	0.0022
080	01754-50820	BOLT FLANGE	2				0.015	0.033

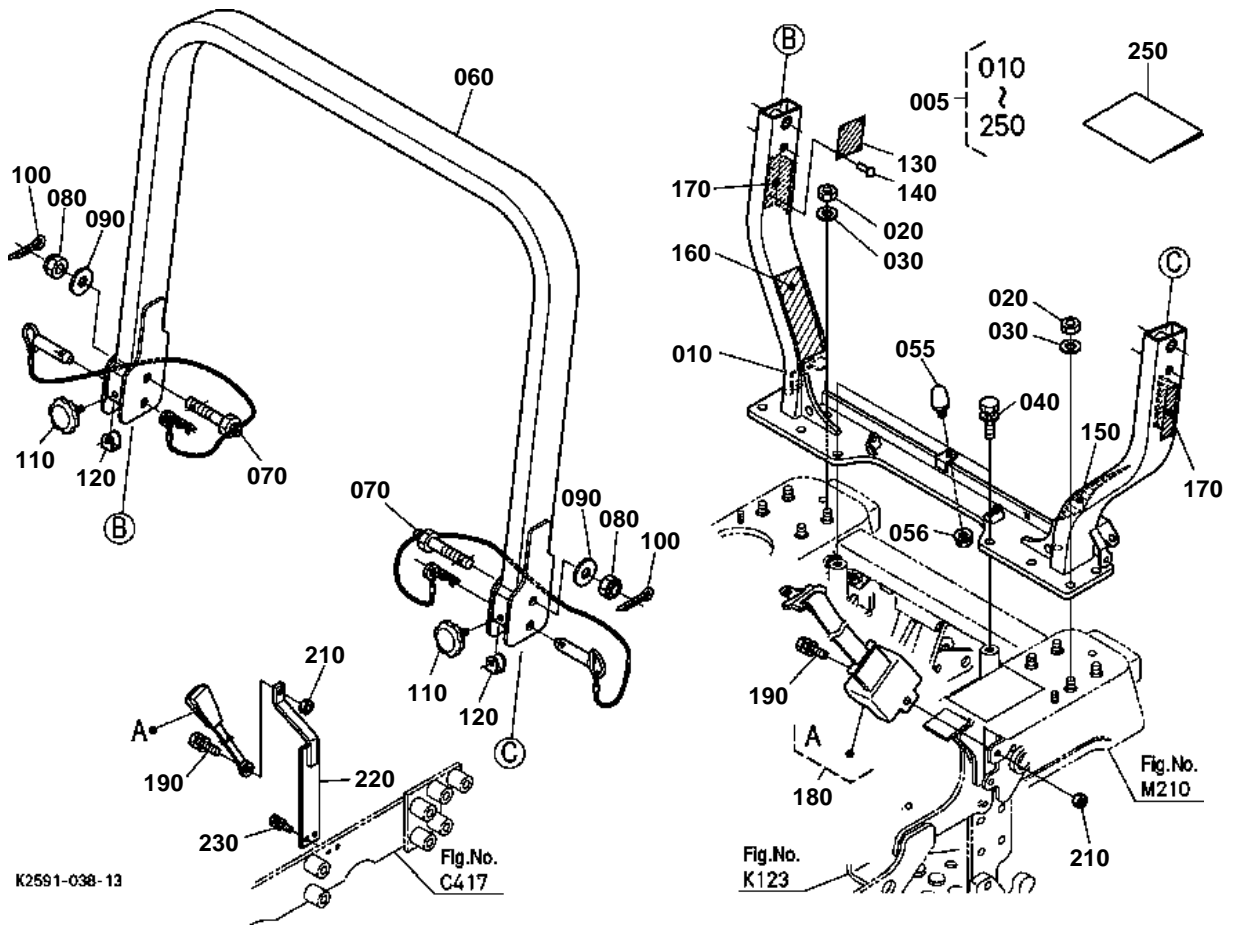

K2591-038-13



ROPS

↔ Interchangeable; ≠ not interchangeable; ← new for old; → old for new

REF.No	Part No.	Description	Q'ty	S.No.	I/C	REMARKS	Weight (kgf)	Weight (lb)
005	K2591-93990	SFBX-F22	1				0	0
010	99999-99999	FRAME	1				0	0
020	02174-50140	NUT	8				0.014	0.0308
030	04512-60140	WASHER SPRING	8				0.008	0.0176
040	01133-51445	BOLT	2				0.073	0.1606
050	99999-99999	BLANK	0				0	0
055	69181-48310	CUSHION	1				0.04	0.088
056	02751-50080	NUT FLANGE	1				0.006	0.0132
060	99999-99999	ROPS UPPER	1				0	0
070	K2591-39400	ASSY BOLT SET	2				0.31	0.682
080	TA240-48360	NUT SOLOTTED	2				0.04	0.088
090	04013-60160	WASHER PLAIN	4				0.01	0.022
100	05511-50430	PIN SPLIT	2				0.004	0.0088
110	53721-61533	CLAMP RAIL COVER	2				0.06	0.132
120	K2591-39560	BRACKET RETAINER	2				0.02	0.044
130	99999-99999	NAME PLATE ROPS	1				0	0
140	K6072-63910	RIVET BLIND BLACK	4				0.002	0.0044
150	K2591-65642	LABEL CAUTION(ROPS)	1			ENGLISH	0.01	0.022
150	K2597-65640	LABEL CAUTION(ROPS)	1			FRENCH	0.01	0.022
160	K2591-65572	LABEL WARNING(ROPS)	1			ENGLISH	0	0
160	K2597-65570	LABEL WARNING(ROPS)	1			FRENCH	0.008	0.0176
170	K2591-65410	LABEL REFLECTOR	2				0.01	0.022
180	K2561-56850	ASSY BELT SEAT	1				0.81	1.782
190	01133-51030	BOLT	2				0.025	0.055
200	99999-99999	BLANK	2				0	0
210	02118-50100	NUT	2				0.005	0.011
220	K2591-56860	STAY SEAT BELT	1				0	0
230	01123-50820	BOLT	2				0.011	0.0242
240	99999-99999	BLANK	0				0	0
250	99999-99999	MANUAL ROPS	1				0	0

SMV EMBLEM

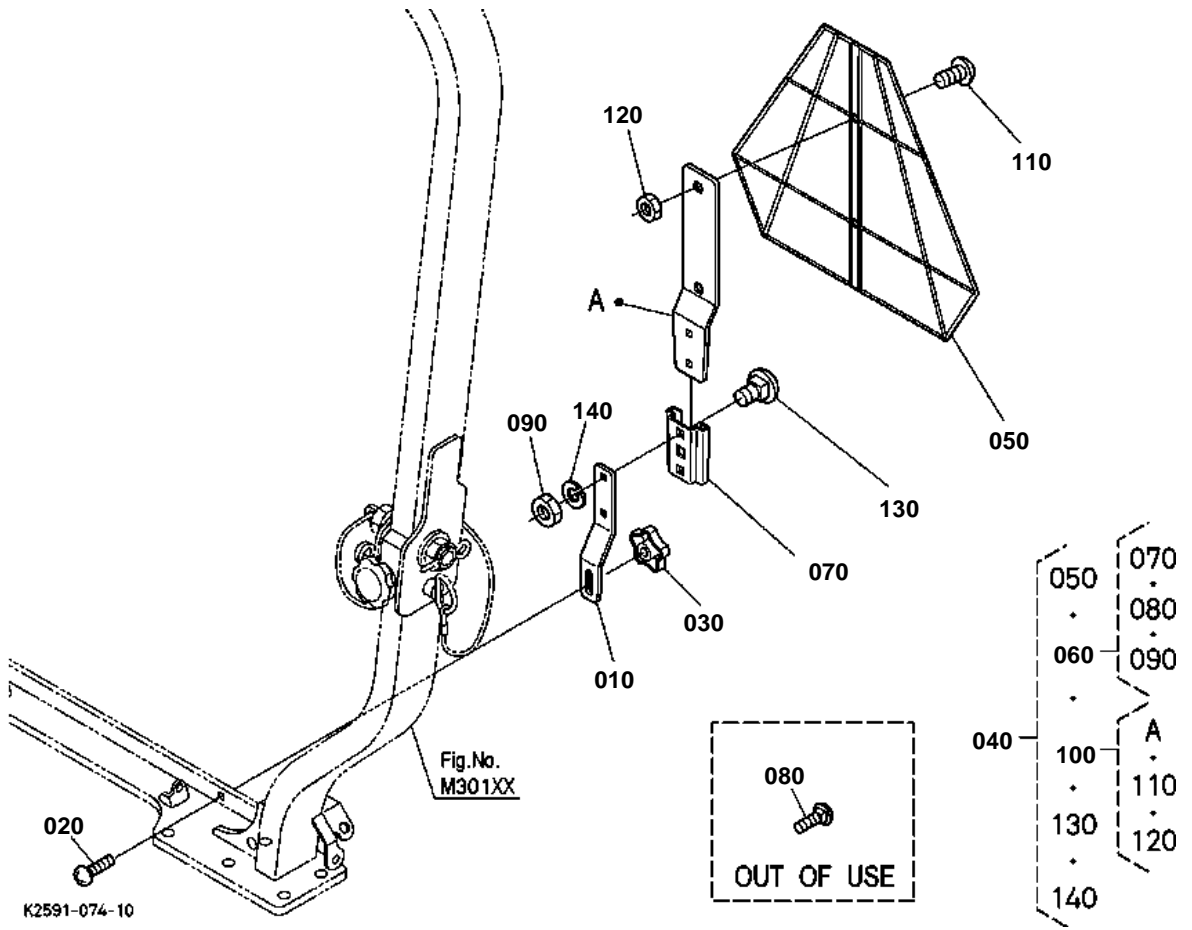

**SMV EMBLEM**

↔ Interchangeable; ≠ not interchangeable; ← new for old; → old for new

REF.No	Part No.	Description	Q'ty	S.No.	I/C	REMARKS	Weight (kgf)	Weight (lb)
010	K2591-39540	BRACKET SMV	1				0.2	0.44
020	K1122-91320	BOLT SHORT SQU.NECK	1				0.01	0.022
030	K2561-57170	NUT KNOB	1				0.015	0.033
040	7L500-89900	SMV SIGN KIT	1			NOT SALE	0	0
040	7L500-89902	SMV SIGN KIT	1		←	NOT SALE	0.25	0.55
050	7L500-89910	SIGN SMV	1				0.32	0.704
060	7L500-89920	SOCKET SMV SIGN	1				0.1	0.22
070	7L500-89930	SOCKET-MTG SMV	1				0.05	0.11
080	7L500-89940	BOLT SQUARE NECK	2			OUT OF USE	0.01	0.022
090	7L500-89950	NUT	2				0.004	0.0088
100	7L500-89960	SPADE SMV SIGN	1				0.24	0.528
110	7L500-89980	VIS	2				0.02	0.044
120	7L500-89990	NUT	2				0.001	0.0022
130	7L500-89810	BOLT SQUARE NECK	2				0.011	0.0242
140	04512-60080	WASHER SPRING	2				0.002	0.0044

FRONT WHEEL (18\*8.50-8)

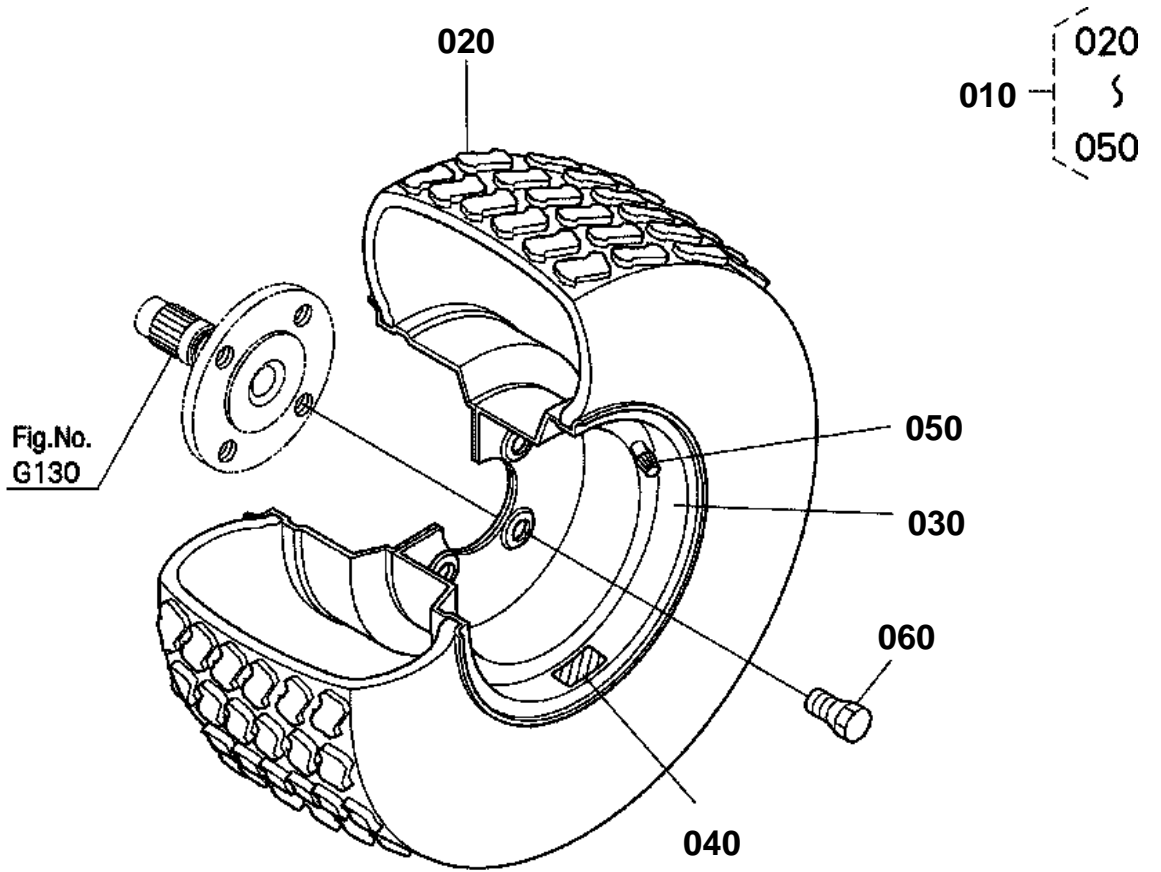

K2571-071-10

**FRONT WHEEL (18\*8.50-8)**

↔ Interchangeable; ≠ not interchangeable; ← new for old; → old for new

REF.No	Part No.	Description	Q'ty	S.No.	I/C	REMARKS	Weight (kgf)	Weight (lb)
010	K2561-18100	TIRE ASSY T	2				7.4	16.28
020	K2561-18140	TIRE T	2				4.48	9.856
030	K2561-18180	WHEEL	2				2.4	5.28
040	K2561-18360	LABEL T	2			NOT SALE	0	0
050	66120-17190	VALVE TIRE	2				0.012	0.0264
060	K2561-18210	BOLT WHEEL	8				0.06	0.132

FRONT WHEEL (18\*8.50-8)

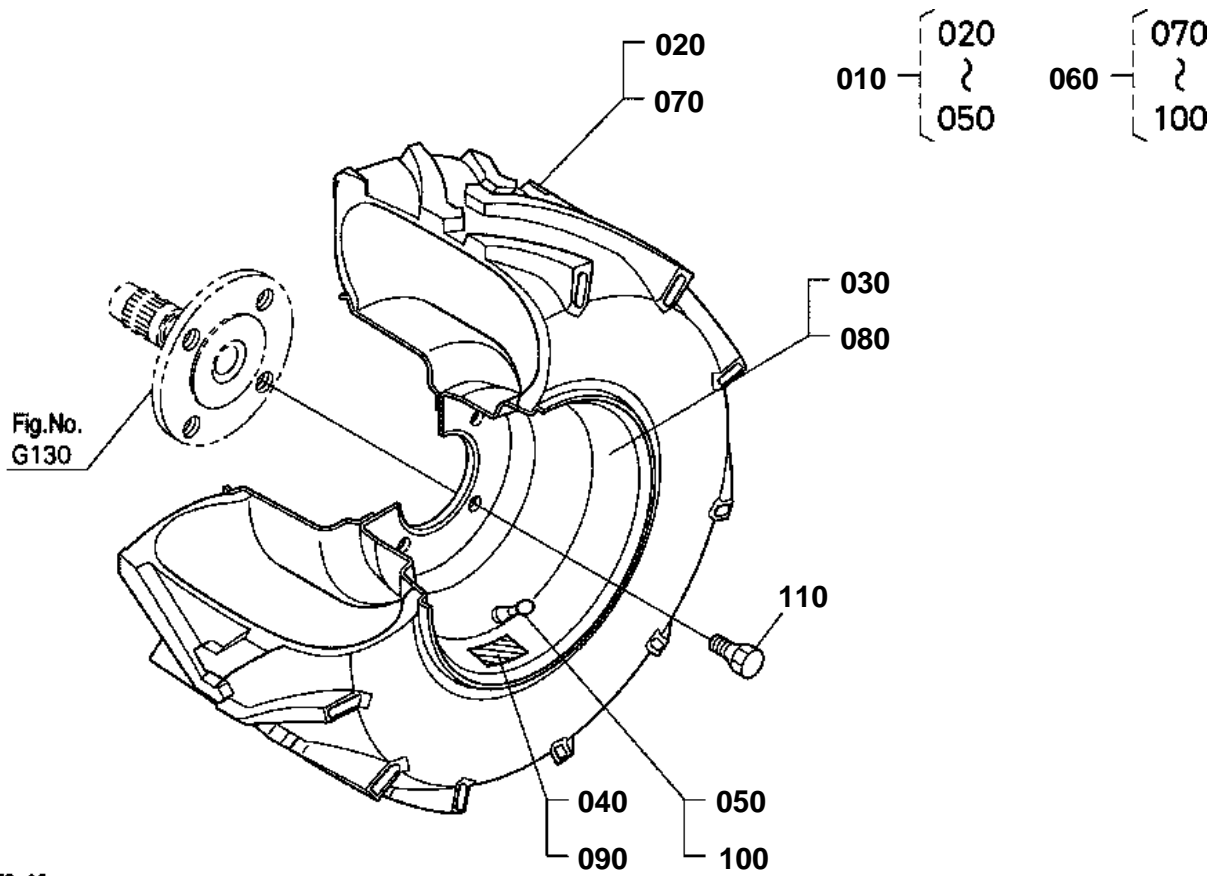

K2571-072-10



**FRONT WHEEL (18\*8.50-8)**

↔ Interchangeable; ≠ not interchangeable; ← new for old; → old for new

REF.No	Part No.	Description	Q'ty	S.No.	I/C	REMARKS	Weight (kgf)	Weight (lb)
010	K2561-18410	TIRE ASSY BL	1				7.8	17.16
020	K2561-18150	TIRE B	1				5.19	11.418
030	K2561-18190	WHEEL B	1				2.64	5.808
040	K2561-18370	LABEL BL	1			NOT SALE	0	0
050	K2561-17220	CORE VALVE	1				0.01	0.022
060	K2561-18420	TIRE ASSY BR	1				7.8	17.16
070	K2561-18150	TIRE B	1				5.19	11.418
080	K2561-18190	WHEEL B	1				2.64	5.808
090	K2561-18380	LABEL BR	1			NOT SALE	0	0
100	K2561-17220	CORE VALVE	1				0.01	0.022
110	K2561-18210	BOLT WHEEL	8				0.06	0.132

REAR WHEEL (26\*12.00-12)

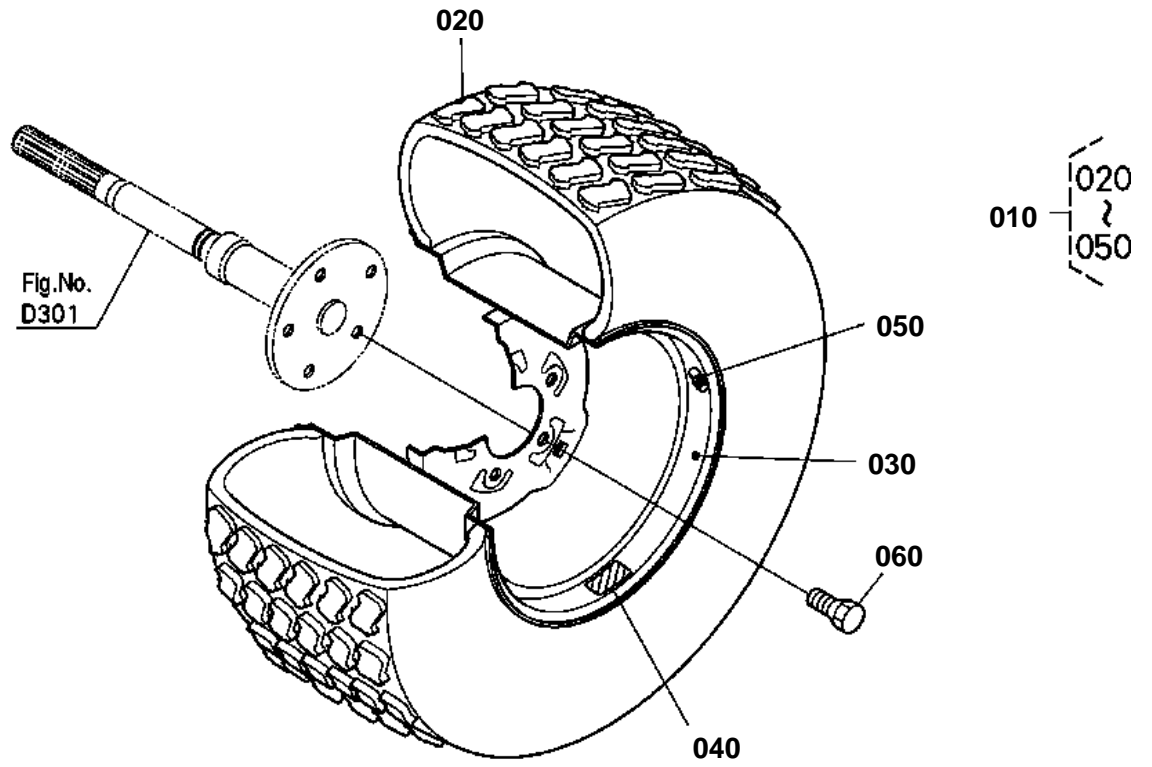

K2571-073-10

**REAR WHEEL (26\*12.00-12)**

↔ Interchangeable; ≠ not interchangeable; ← new for old; → old for new

REF.No	Part No.	Description	Q'ty	S.No.	I/C	REMARKS	Weight (kgf)	Weight (lb)
010	K2561-17100	TIRE ASSY T	2				19.8	43.56
020	K2561-17140	TIRE T	2				12.1	26.62
030	K2561-17180	WHEEL	2				6.2	13.64
040	K2561-17360	LABEL T	2			NOT SALE	0	0
050	66120-17190	VALVE TIRE	2				0.012	0.0264
060	K2561-17210	BOLT WHEEL	10				0.06	0.132

REAR WHEEL (26\*12.00-12)

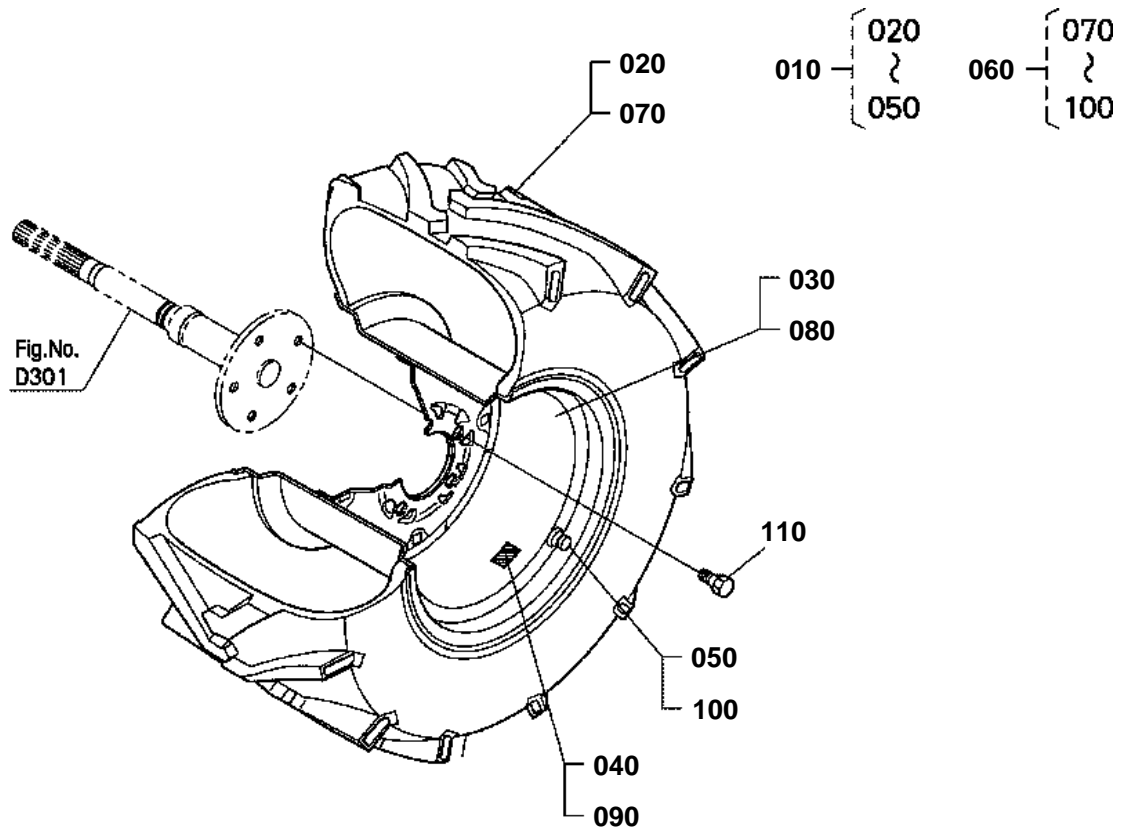

K2571-074-10

**REAR WHEEL (26\*12.00-12)**

↔ Interchangeable; ≠ not interchangeable; ← new for old; → old for new

REF.No	Part No.	Description	Q'ty	S.No.	I/C	REMARKS	Weight (kgf)	Weight (lb)
010	K2561-17410	TIRE ASSY BL	1				20.4	44.88
020	K2561-17150	TIRE B	1				0	0
030	K2561-17190	WHEEL B	1				7.4	16.28
040	K2561-17370	LABEL BL	1			NOT SALE	0	0
050	K2561-17220	CORE VALVE	1				0.01	0.022
060	K2561-17420	TIRE ASSY BR	1				20.4	44.88
070	K2561-17150	TIRE B	1				0	0
080	K2561-17190	WHEEL B	1				7.4	16.28
090	K2561-17380	LABEL BR	1			NOT SALE	0	0
100	K2561-17220	CORE VALVE	1				0.01	0.022
110	K2561-17210	BOLT WHEEL	10				0.06	0.132

LABEL (FRONT) [ENGLISH]

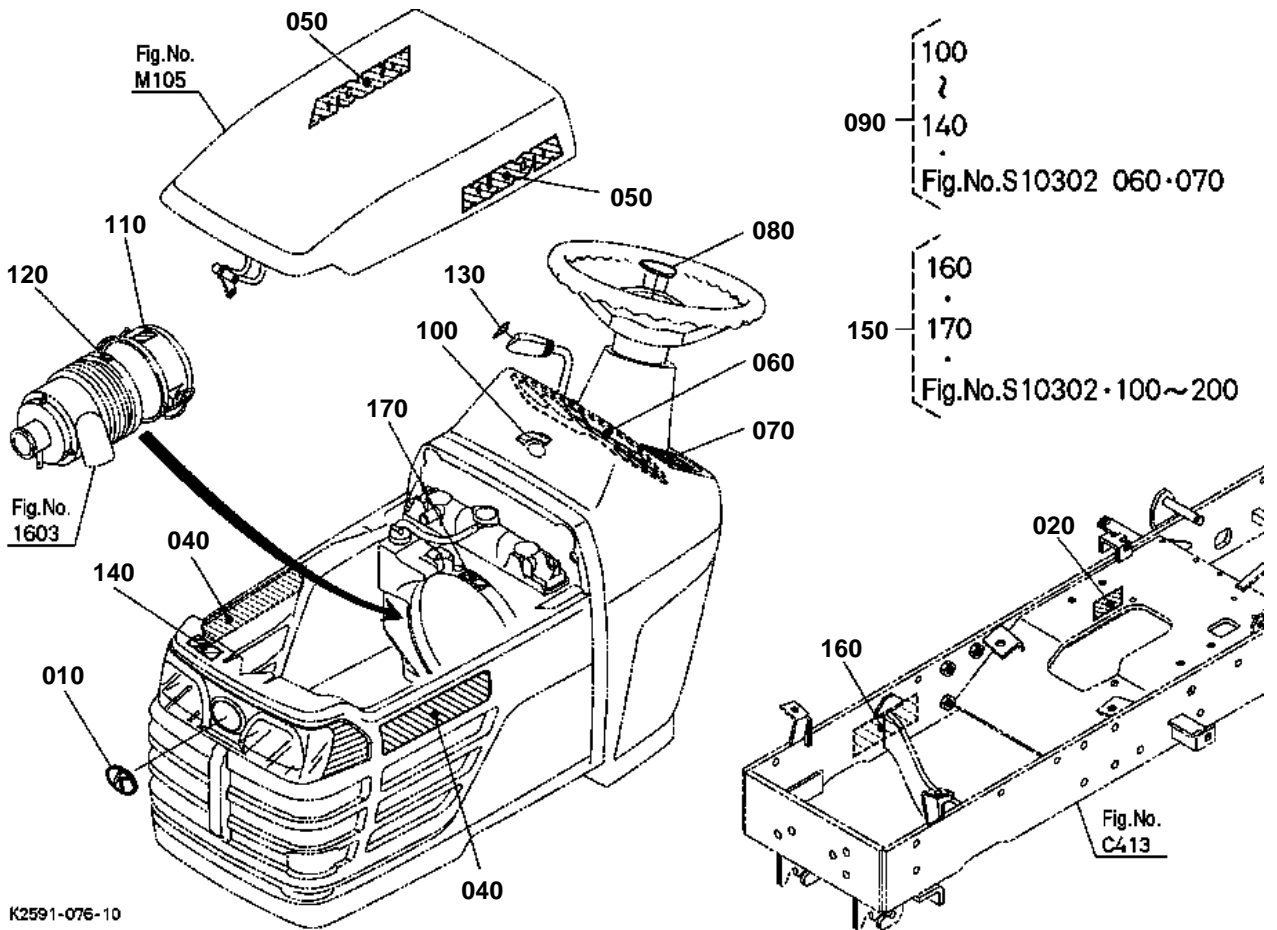



## LABEL (FRONT) [ENGLISH]

↔ Interchangeable; ≠ not interchangeable; ← new for old; → old for new

REF.No	Part No.	Description	Q'ty	S.No.	I/C	REMARKS	Weight (kgf)	Weight (lb)
010	T1060-49500	MARK SYMBOL	1				0.01	0.022
020	99999-99999	NAME PLATE	1				0	0
030	99999-99999	BLANK	0				0	0
040	K2591-65135	LABEL BX	2				0.01	0.022
050	K2571-65120	LABEL KUBOTA	2				0	0
060	K2561-65213	PLATE INDICATOR	1				0.12	0.264
070	K2561-65220	LABEL LIGHT SWITCH	1				0.005	0.011
080	K2561-65240	MARK STEERING WHEEL	1				0.01	0.022
090	K2561-65200	LABEL SET	1				0.016	0.0352
100	K2561-65230	LABEL SWITCH	1			NOT SALE	0	0
110	K2561-65330	LABEL CLEANER TOP	1			NOT SALE	0	0
120	K2561-65340	LABEL CLEANER ARROW	1			NOT SALE	0	0
130	K2561-65290	LABEL ACCEL.	1			NOT SALE	0	0
140	K2561-65420	LABEL HOT CAUTION	1			NOT SALE	0	0
150	K2561-65405	LABEL SET	1				0.022	0.0484
160	K2561-65410	LABEL START DANGER	1			NOT SALE	0	0
170	K2561-65430	LABEL FAN CAUTION	1			NOT SALE	0	0

LABEL (FRONT) [FRENCH]

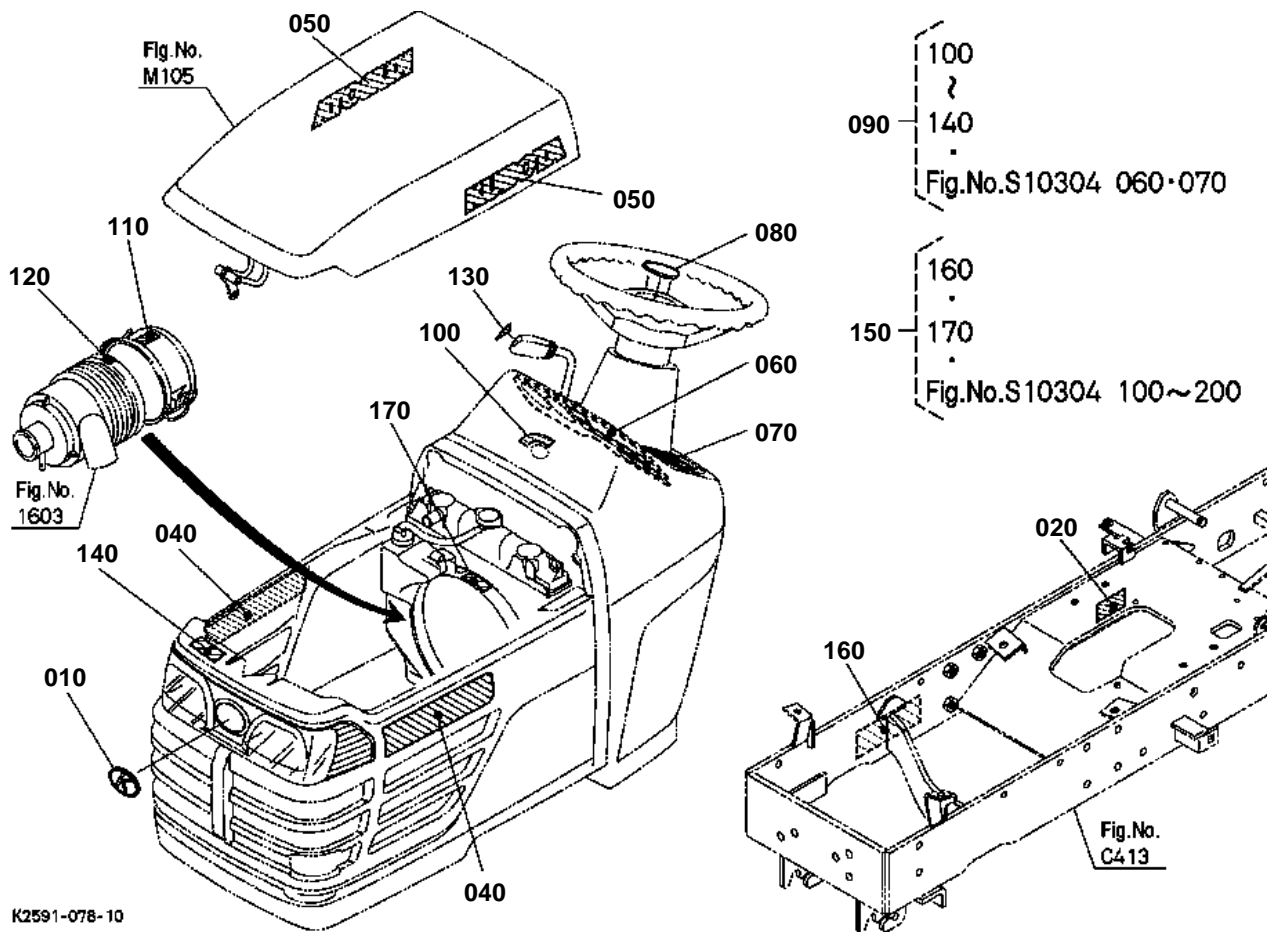



**LABEL (FRONT) [FRENCH]**

↔ Interchangeable; ≠ not interchangeable; ← new for old; → old for new

REF.No	Part No.	Description	Q'ty	S.No.	I/C	REMARKS	Weight (kgf)	Weight (lb)
010	T1060-49500	MARK SYMBOL	1				0.01	0.022
020	99999-99999	NAME PLATE	1				0	0
030	99999-99999	BLANK	0				0	0
040	K2591-65135	LABEL BX	2				0.01	0.022
050	K2571-65120	LABEL KUBOTA	2				0	0
060	K2561-65213	PLATE INDICATOR	1				0.12	0.264
070	K2561-65220	LABEL LIGHT SWITCH	1				0.005	0.011
080	K2561-65240	MARK STEERING WHEEL	1				0.01	0.022
090	K2561-65200	LABEL SET	1				0.016	0.0352
100	K2561-65230	LABEL SWITCH	1			NOT SALE	0	0
110	K2561-65330	LABEL CLEANER TOP	1			NOT SALE	0	0
120	K2561-65340	LABEL CLEANER ARROW	1			NOT SALE	0	0
130	K2561-65290	LABEL ACCEL.	1			NOT SALE	0	0
140	K2561-65420	LABEL HOT CAUTION	1			NOT SALE	0	0
150	K2567-65405	LABEL SET CA	1				0.045	0.099
160	K2567-65410	LABEL START DANGER F	1			NOT SALE	0	0
170	K2561-65430	LABEL FAN CAUTION	1			NOT SALE	0	0

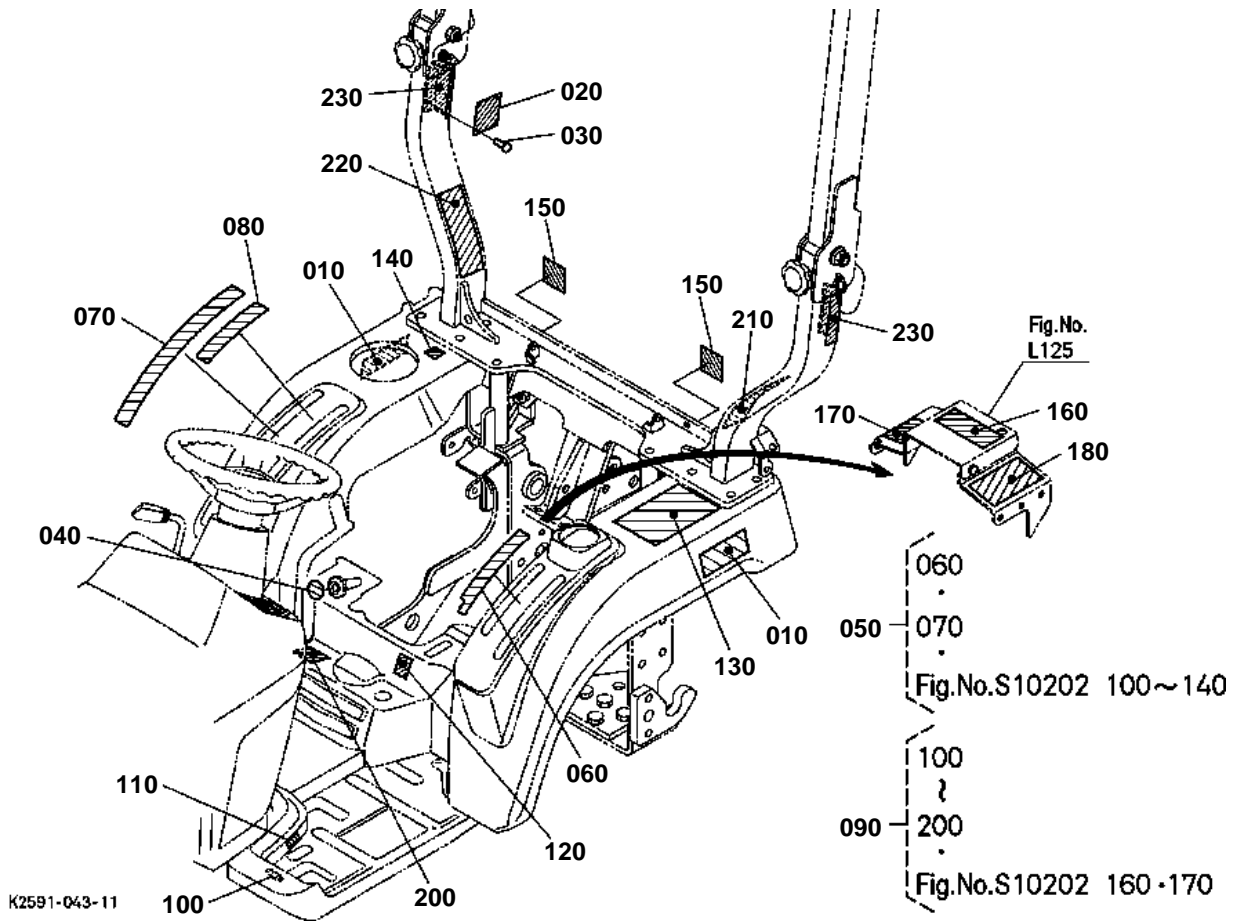



## LABEL (REAR) [ENGLISH]

↔ Interchangeable; ≠ not interchangeable; ← new for old; → old for new

REF.No	Part No.	Description	Q'ty	S.No.	I/C	REMARKS	Weight (kgf)	Weight (lb)
010	K2571-65250	LABEL 4WD	2				0	0
020	99999-99999	NAME PLATE ROPS	1				0	0
030	K6072-63910	RIVET BLIND BLACK	4				0.002	0.0044
040	K2561-65263	LABEL HYD ADJUST	1				0.001	0.0022
050	K2561-65200	LABEL SET	1				0.016	0.0352
060	K2561-65270	LABEL GUIDE LH	1			NOT SALE	0	0
070	K2561-65280	LABEL GUIDE RH	1			NOT SALE	0	0
080	K2591-65390	LABEL COVER	1				0	0
090	K2561-65405	LABEL SET	1				0.022	0.0484
100	K2561-65440	LABEL DIFF.LOCK	1			NOT SALE	0	0
110	K2561-65450	LABEL	1			NOT SALE	0	0
120	K2561-65460	LABEL ADJUSTPOSITION	1			NOT SALE	0	0
130	K2561-65482	LABEL SAFETY	1			NOT SALE	0	0
140	K2561-65490	LABEL FUEL FILTER	1			NOT SALE	0	0
150	K2561-65522	LABEL SPACE WARNING	2			NOT SALE	0	0
160	K2561-65540	LABEL PTO WARNING	1			NOT SALE	0	0
170	K2561-65550	LABEL ADJUST CAUTION	1			NOT SALE	0	0
180	K2561-65560	LABEL HITCH WARNING	1			NOT SALE	0	0
190	K2561-65570	LABEL ROPS WARNING	1			NOT SALE OUT OF USE	0	0
200	K2561-65622	LABEL SHIFT LEVER	1			NOT SALE	0	0
210	K2591-65642	LABEL CAUTION(ROPS)	1				0.01	0.022
220	K2591-65572	LABEL WARNING(ROPS)	1				0	0
230	K2591-65410	LABEL REFLECTOR	2				0.01	0.022

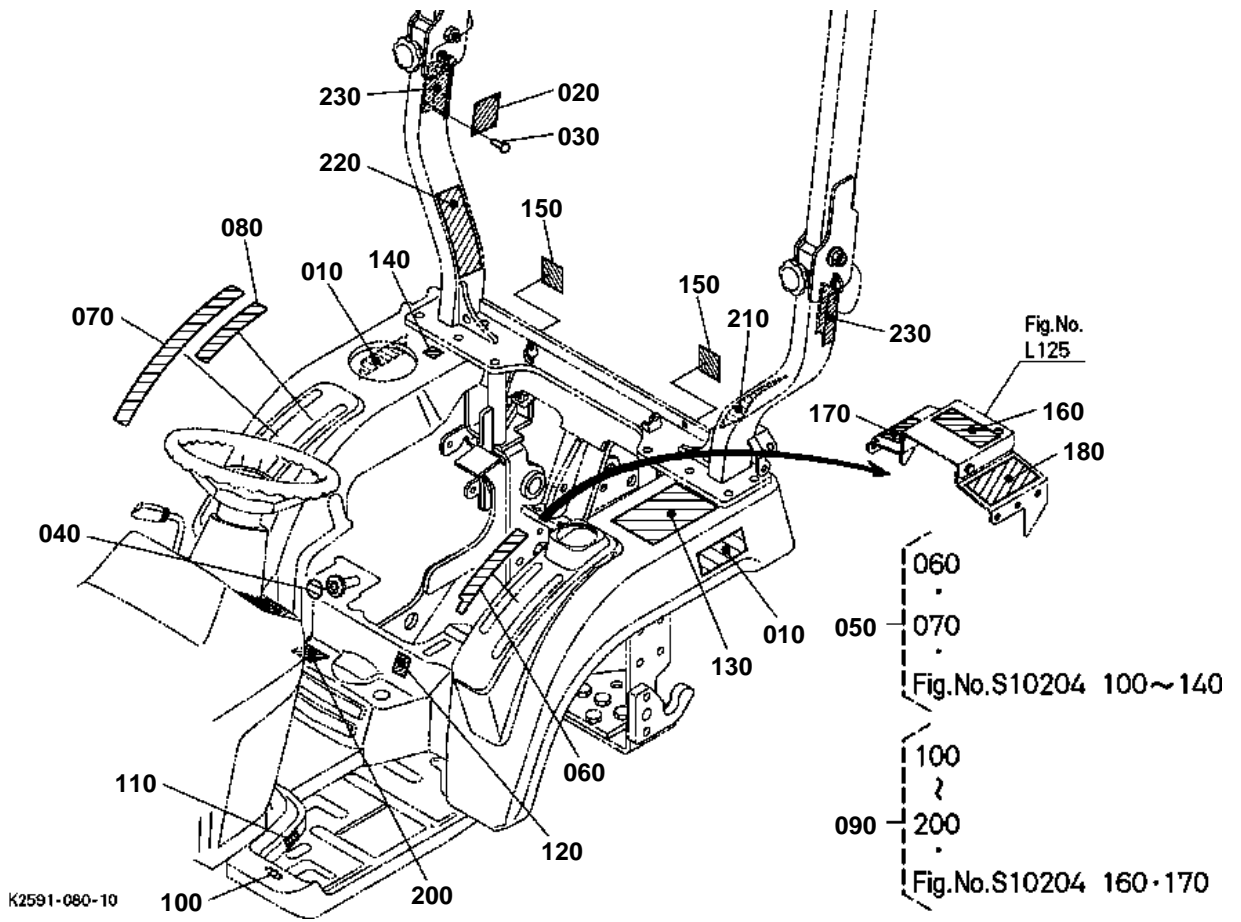



## LABEL (REAR) [FRENCH]

↔ Interchangeable; ≠ not interchangeable; ← new for old; → old for new

REF.No	Part No.	Description	Q'ty	S.No.	I/C	REMARKS	Weight (kgf)	Weight (lb)
010	K2571-65250	LABEL 4WD	2				0	0
020	99999-99999	NAME PLATE ROPS	1				0	0
030	K6072-63910	RIVET BLIND BLACK	4				0.002	0.0044
040	K2561-65263	LABEL HYD ADJUST	1				0.001	0.0022
050	K2561-65200	LABEL SET	1				0.016	0.0352
060	K2561-65270	LABEL GUIDE LH	1			NOT SALE	0	0
070	K2561-65280	LABEL GUIDE RH	1			NOT SALE	0	0
080	K2591-65390	LABEL COVER	1				0	0
090	K2567-65405	LABEL SET CA	1				0.045	0.099
100	K2561-65440	LABEL DIFF.LOCK	1			NOT SALE	0	0
110	K2561-65450	LABEL	1			NOT SALE	0	0
120	K2561-65460	LABEL ADJUSTPOSITION	1			NOT SALE	0	0
130	K2567-65482	LABEL SAFETY	1			NOT SALE	0	0
140	K2561-65490	LABEL FUEL FILTER	1			NOT SALE	0	0
150	K2567-65520	LABEL SPACE WARNING	2			NOT SALE	0	0
160	K2567-65540	LABEL PTO WARNING	1			NOT SALE	0	0
170	K2567-65550	LABEL ADJUST CAUTION	1			NOT SALE	0	0
180	K2567-65560	LABEL HITCH WARNING	1			NOT SALE	0	0
190	K2567-65570	LABEL ROPS WARNING	1			NOT SALE OUT OF USE	0	0
200	K2561-65622	LABEL SHIFT LEVER	1			NOT SALE	0	0
210	K2597-65640	LABEL CAUTION(ROPS)	1				0.01	0.022
220	K2597-65570	LABEL WARNING(ROPS)	1				0.008	0.0176
230	K2591-65410	LABEL REFLECTOR	2				0.01	0.022

**ACCESSORIES AND SERVICE PARTS  
ACCESSOIRES ET PIECES DE SERVICE  
SONTIGES ZUBEHOER UND SERVICE-TEILE**

TITLE-001-10



## ACCESSORIES AND SERVICE PARTS

↔ Interchangeable; ≠ not interchangeable; ← new for old; → old for new

REF.No	Part No.	Description	Q'ty	S.No.	I/C	REMARKS	Weight (kgf)	Weight (lb)
010	K2591-71220	OPERATOR'S MANUAL	1			ENGLISH	0	0
010	K2597-71212	OPERATORS MANUAL CA	1			FRENCH	0.278	0.6116
020	K2591-71512	MANUAL ASSEMBLY	1			NOT SALE	0	0
030	K2591-73210	ASSY ACCESSORIES	1			NOT SALE	0	0
040	K1122-73220	BAG VINYL	1				0.015	0.033

ALTERNATOR KIT [OPTION]

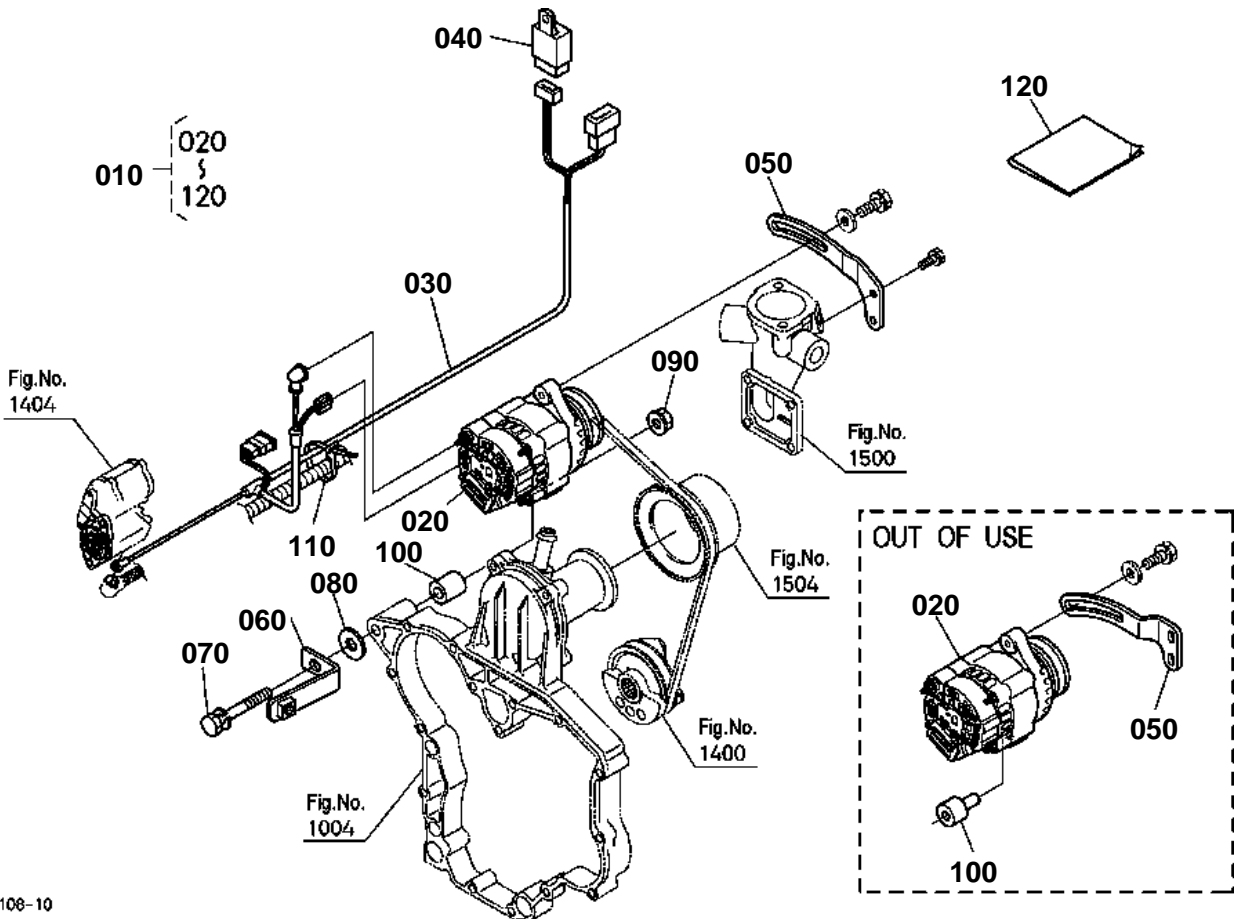

K2591-106-10





# ALTERNATOR KIT [OPTION]

↔ Interchangeable; ≠ not interchangeable; ← new for old; → old for new

REF.No	Part No.	Description	Q'ty	S.No.	I/C	REMARKS	Weight (kgf)	Weight (lb)
010	K2571-98620	KIT ALTERNATOR	1				0	0
020	16241-64012	ASSY ALTERNATOR	1				3	6.6
030	K2561-99810	WIRE HARNES ALT.	1				0.093	0.2046
040	68881-53540	COMP.RELAY	1				0.04	0.088
050	16241-64420	STAY DYNAMO	1				0.095	0.209
050	16826-64420	STAY ALTERNATOR	1			OUT OF USE	0.108	0.2376
060	K2571-99830	SUPPORT GAUGE GUIDE	1				0	0
070	01123-51085	BOLT	1				0.055	0.121
070	01123-50885	BOLT	1			OUT OF USE	0.033	0.0726
080	04013-60100	WASHER PLAIN	1				0.003	0.0066
080	04013-60080	WASHER PLAIN	1			OUT OF USE	0.002	0.0044
090	02771-60100	NUT FLANGE	1				0.01	0.022
090	02751-50080	NUT FLANGE	1			OUT OF USE	0.006	0.0132
100	6C040-95330	COLLAR ALTERNATOR	1				0.031	0.0682
100	19837-64374	COLLAR	1			OUT OF USE	0.06	0.132
110	K1122-61230	CLAMP CORD	1				0.001	0.0022
120	99999-99999	MANUAL ALT.KIT	1				0	0

ALTERNATOR [COMPONENT PARTS][OPTION]

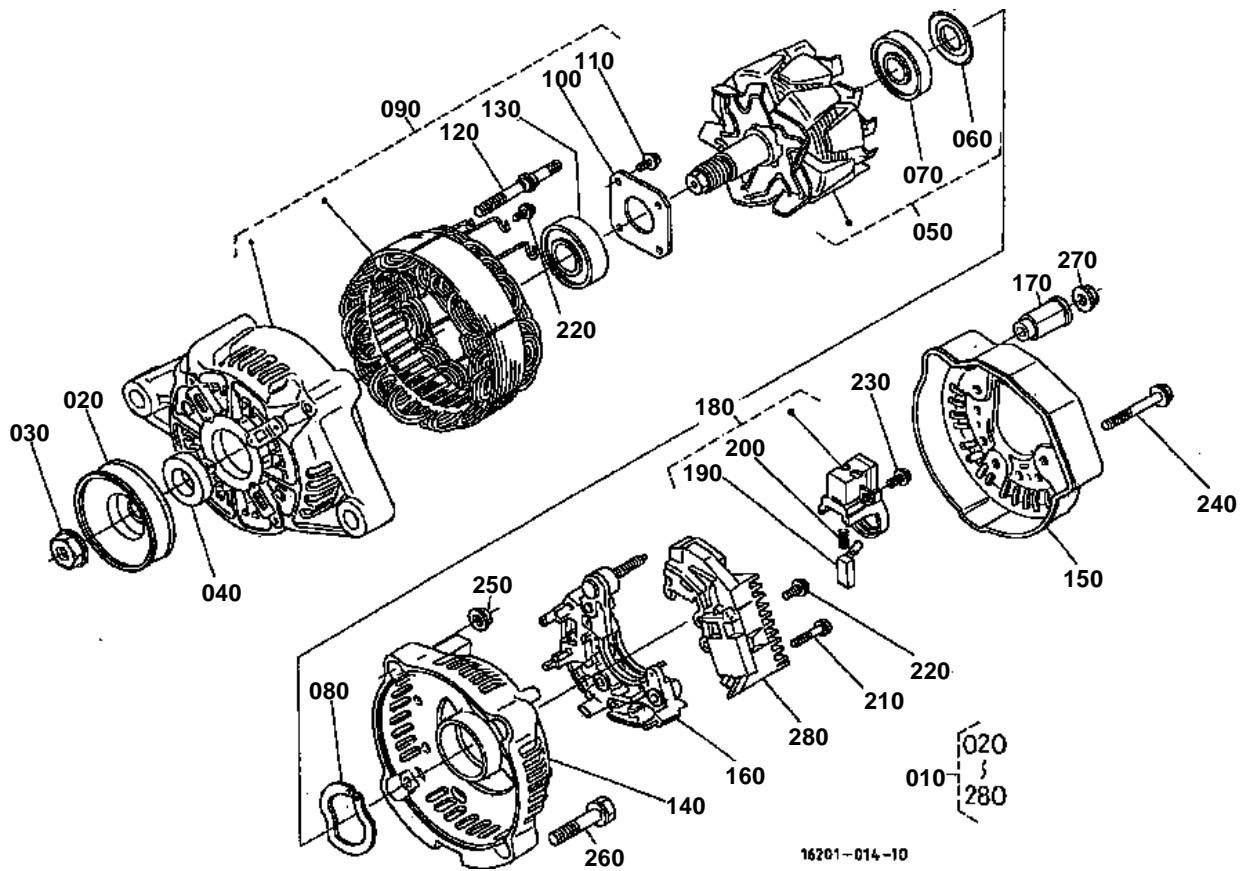

**ALTERNATOR [COMPONENT PARTS][OPTION]**

↔ Interchangeable; ≠ not interchangeable; ← new for old; → old for new

REF.No	Part No.	Description	Q'ty	S.No.	I/C	REMARKS	Weight (kgf)	Weight (lb)
010	16241-64012	ASSY ALTERNATOR	1				3	6.6
020	15881-64110	PULLEY DYNAMO	1				0.16	0.352
030	15881-92010	NUT	1				0.02	0.044
040	15881-64150	COLLAR	1				0.004	0.0088
050	66436-64040	ROTOR	1				1.2	2.64
060	15881-64800	COVER BEARING	1				0.001	0.0022
070	16652-64770	BEARING BALL	1				0.045	0.099
080	15881-64810	WASHER THRUST	1				0.002	0.0044
090	66436-64020	FRAME DRIVE END	1				1.11	2.442
100	15881-64710	PLATE RETAINER	1				0.01	0.022
110	15881-93010	SCREW ROUND HEAD	4				0.003	0.0066
120	15881-64260	BOLT THROUGH	2				0.01	0.022
130	16652-64780	BEARING BALL	1				0.05	0.11
140	16231-64060	FRAME END	1				0.17	0.374
150	16231-64230	COVER END	1				0.035	0.077
160	16231-64850	ASSY RECTIFIER	1				0.18	0.396
170	16241-64900	BUSH INSULATION	1				0.007	0.0154
180	16652-64310	HOLDER BRUSH	1				0.025	0.055
190	15881-64090	BRUSH	2				0.002	0.0044
200	15881-64330	SPRING BRUSH	2				0.002	0.0044
210	15881-93020	SCREW ROUND HEAD	2				0.005	0.011
220	15881-93030	SCREW ROUND HEAD	6				0.003	0.0066
230	15881-93040	SCREW ROUND HEAD	1				0.003	0.0066
240	15881-91040	BOLT	3				0.005	0.011
250	15881-92020	NUT	2				0.02	0.044
260	15881-91050	BOLT	2				0.01	0.022
270	14182-92030	NUT	1				0.003	0.0066
280	15881-64600	ASSY REGULATOR	1				0	0
280	1K531-64600	ASSY REGULATOR	1			↔	0.08	0.176

WORKING LIGHT KIT [OPTION]

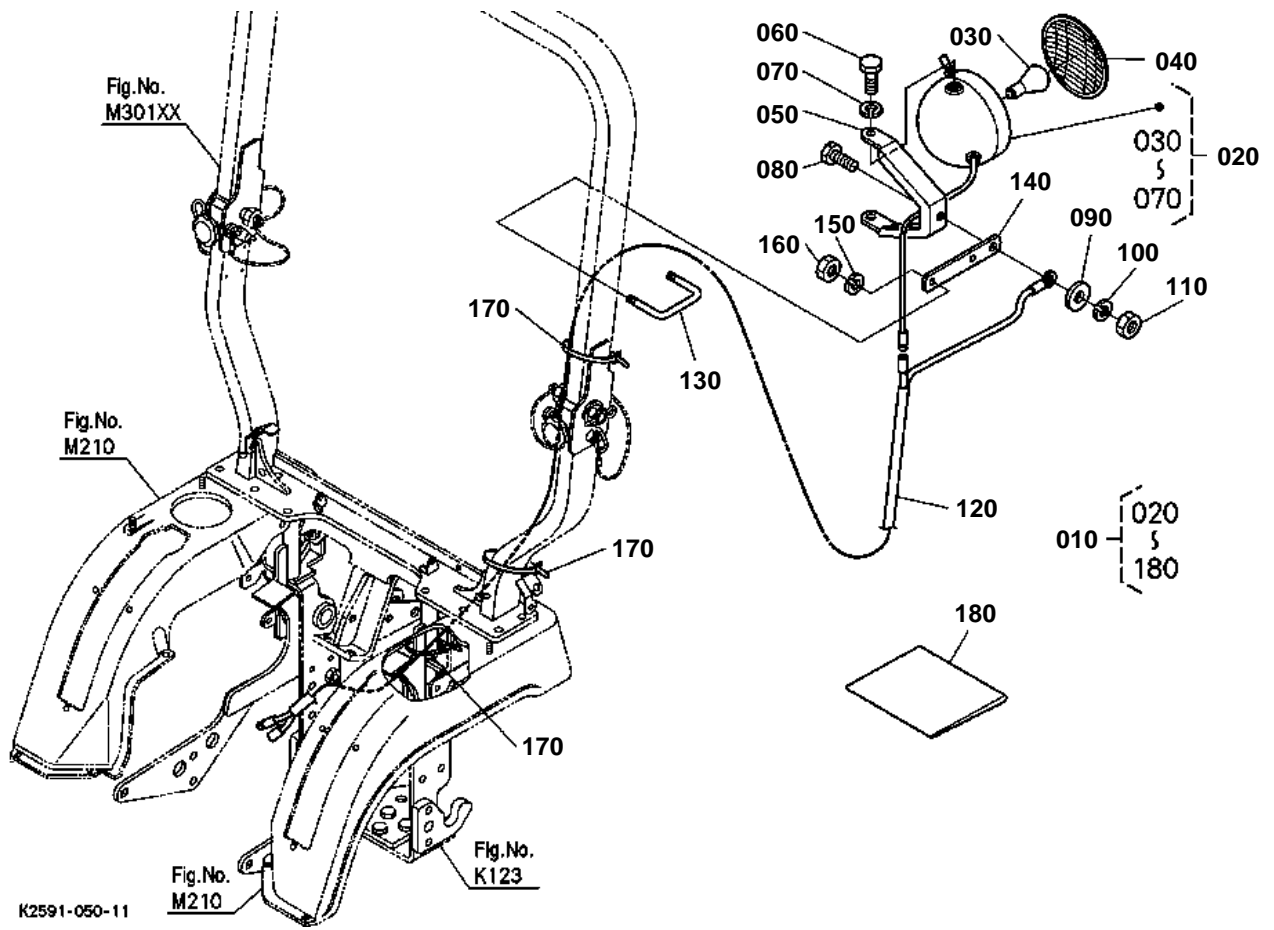



## WORKING LIGHT KIT [OPTION]

↔ Interchangeable; ≠ not interchangeable; ← new for old; → old for new

REF.No	Part No.	Description	Q'ty	S.No.	I/C	REMARKS	Weight (kgf)	Weight (lb)
010	K2561-96290	LIGHT WORKING KIT	1				1.93	4.246
020	35305-31402	ASSY LIGHT WORKING	1				0.805	1.771
030	68331-53360	BLUB	1				0.015	0.033
040	68331-53310	LENS	1				0.15	0.33
050	35305-31410	STAY LIGHT	1				0.24	0.528
060	01153-50820	BOLT	2				0.012	0.0264
070	04512-60080	WASHER SPRING	2				0.002	0.0044
080	01073-51025	BOLT	1				0.025	0.055
090	75599-32013	WASHER PLAIN	1				0.03	0.066
100	04512-60100	WASHER SPRING	1				0.002	0.0044
110	02018-50100	NUT	1				0.011	0.0242
120	K2561-96220	WIRE HARNES W.LIGHT	1				0.06	0.132
130	K2561-96240	ROD U THREAD	1				0.068	0.1496
140	K2561-96250	PLATE WORKING LIGHT	1				0.18	0.396
150	75599-33012	WASHER SPRING	2				0.002	0.0044
160	02054-50080	NUT	2				0.005	0.011
170	K2561-96260	TIE RELEASABLE	3				0.006	0.0132
180	99999-99999	MANUAL LIGHT KIT	1				0	0