

Instructions for Parts Books

The heading at the top of the page will be the same for the picture of the parts as it is for the page with the part numbers.

Definition of column headings on part number pages:

REF.No → The number referring to the part on the picture page of the parts book.

Part No. → The number assigned to this part at the time of printing the parts book.

Description → Description of part.

Q'ty → Quantity of part used on that page.

S.No. → Serial number range of the equipment that this part will fit.

>= Your serial number should be greater than or equal to the number shown.

<= Your serial number should be lesser than or equal to the serial number shown.

I/C → Interchangeability of part shown.

↔ The part shown will work for the older and later serial number.

The part shown is not interchangeable with the other serial number.

← new for old

→ old for new

Remarks → Notes about this particular part. Sometimes this may say except [FR] or [CA]

Note about Country Codes:

The parts books we use in the United States of America may also contain information about a part that would be different in another country. It is important that you are aware of the country codes in some instances.

Symbol	Country
A	United States of America
CA	Canada
FR	France
GR	Greece
PO	Portugal
AU	Australia

If the remarks column says for example EXCEPT [FR] this part works in all countries except France. That means it will work here in the USA.

ALL PRODUCT INDEX
L235

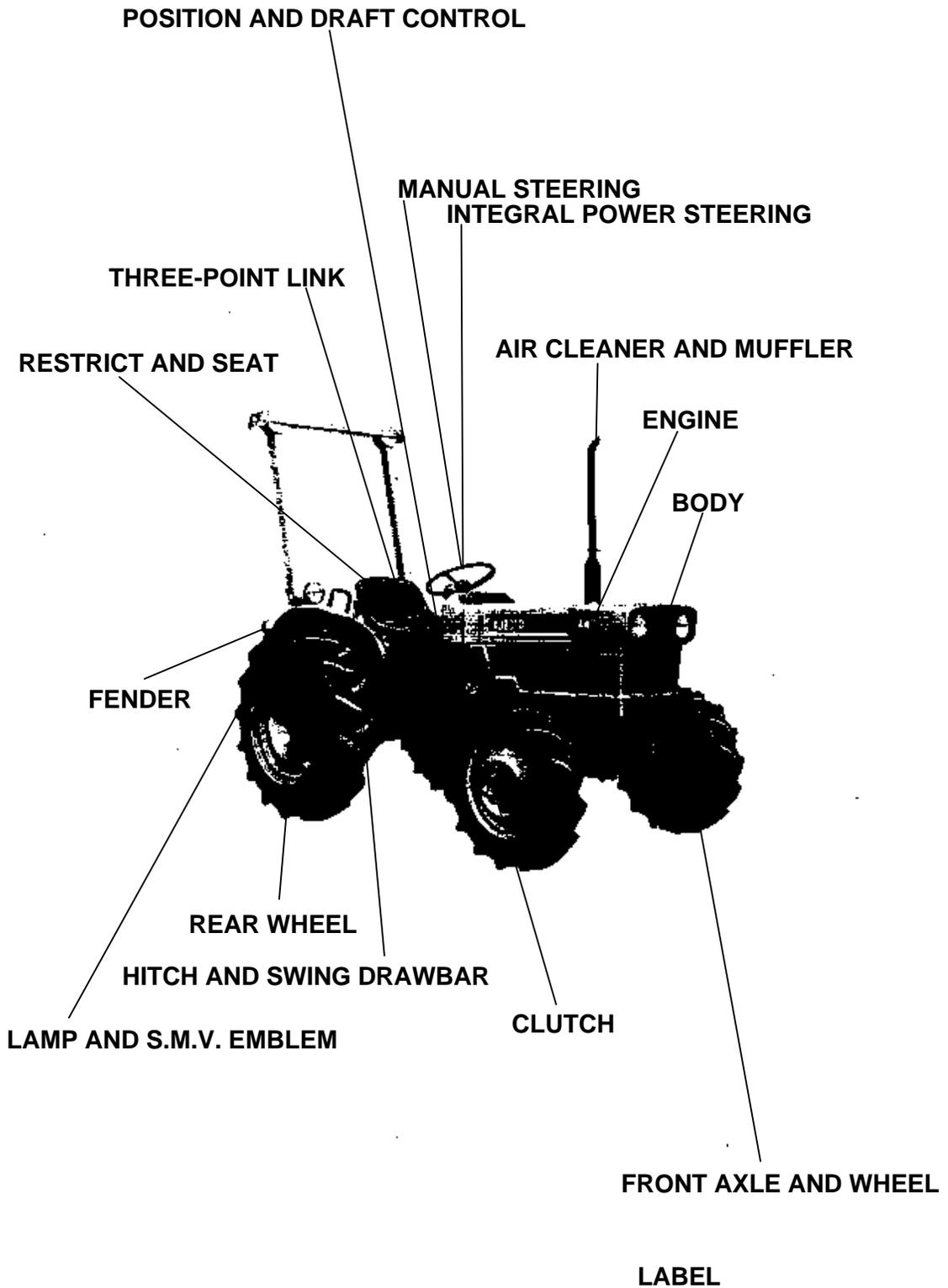

Item	Part No.	Description	Book	
ENGINE	01001	CRANKCASE	100K0350	
	01002	OIL PAN	100K0350	
	01003	CYLINDER HEAD	100K0350	
	01004	GEAR CASE	100K0350	
	01005	MAIN BEARING CASE	100K0350	
	01006	INLET AND EXHAUST MANIFOLD	100K0350	
	01007	VALVE AND ROCKER ARM	100K0350	
	01008	HEAD COVER	100K0350	
	01009	CAMSHAFT	100K0350	
	01010	PISTON AND CRANKSHAFT	100K0350	
	0101101	FLYWHEEL (SINGLE CLUTCH)	100K0350	
	0101102	FLYWHEEL (DUAL CLUTCH)	100K0350	
	01012	STARTER SECTION PARTS	100K0350	
	01013	NOZZLE HOLDER	100K0350	
	01014	NOZZLE HOLDER SECTION PARTS	100K0350	
	01015	FUEL CAMSHAFT	100K0350	
	01016	INJECTION PUMP SECTION PARTS	100K0350	
	01017	GOVERNOR	100K0350	
	01018	SPEED CONTROL PLATE	100K0350	
	01019	ENGINE STOP LEVER	100K0350	
	01020	DYNAMO	100K0350	
	01021	DYNAMO SECTION PARTS	100K0350	
	01022	RADIATOR	100K0350	
	01023	WATER PIPE	100K0350	
	01024	WATER PUMP	100K0350	
	0102501	CLUTCH (SINGLE CLUTCH)	100K0350	
	0102502	CLUTCH (DUAL CLUTCH)	100K0350	
	01026	OIL HYDRAULIC PUMP	100K0350	
	01027	OIL HYDRAULIC PUMP SECTION PARTS	100K0350	
	BODY	01028	BUMPER	100K0350
		01029	BATTERY SUPPORT	100K0350
		01030	SAFETY COVER	100K0350
		01031	MID CASE	100K0350
		01032	CLUTCH ROD	100K0350
		01033	STEERING WHEEL	100K0350
		01034	HAND ACCELERATOR	100K0350
		01035	HOOD	100K0350
		01036	MAIN SHIFT LEVER	100K0350
		01037	GEAR DRIVE SYSTEM	100K0350
		01038	COUNTER SHAFT	100K0350
		01039	CONDUCT SHAFT	100K0350
		01040	REVERSE SHAFT	100K0350
		01041	SPIRAL BEVEL PINION	100K0350
		01042	POWER TAKE-OFF SHAFT	100K0350
		01043	SPEED CHANGE SYSTEM 1	100K0350
		01044	SPEED CHANGE SYSTEM 2	100K0350
		01045	PTO SHIFT LEVER	100K0350
		01046	DIFFERENTIAL LOCK PEDAL	100K0350
01047		REAR AXLE	100K0350	
01048		TRANSMISSION CASE	100K0350	
01049		BRAKE PEDAL	100K0350	
01050		STEP	100K0350	
01051		PANEL 1	100K0350	
01052		PANEL 2	100K0350	
01053		HEAD LAMP	100K0350	
01054		WIRING DIAGRAM	100K0350	

Item	Part No.	Description	Book	
BODY	01055	FUEL TANK	100K0350	
	01056	FUEL FILTER	100K0350	
	01057	OIL HYDRAULIC SYSTEM 1	100K0350	
	01058	OIL HYDRAULIC SYSTEM 2	100K0350	
	01059	OIL HYDRAULIC CYLINDER	100K0350	
	01060	OIL HYDRAULIC CYLINDER COVER	100K0350	
	01061	LIFT ARM	100K0350	
	01062	OIL HYDRAULIC PIPING	100K0350	
	01063	DIFFERENTIAL SYSTEM	100K0350	
	01064	DIFF BEARING CASE	100K0350	
	THREE-POINT LINK	01067	3-POINT LINK 1	100K0350
		01068	3-POINT LINK 2	100K0350
	FRONT AXLE AND WHEEL	01069	FRONT WHEEL (4.00-15) [2WD]	100K0350
		01070	FRONT WHEEL (6-14) [4WD]	100K0350
01071		FRONT WHEEL (25X8.50-14) [4WD]	100K0350	
01073		FRONT WHEEL (23X8.50-12) [L235(2WD)/L275(4WD)]	100K0350	
REAR WHEEL	01076	REAR WHEEL (9.5-24)	100K0350	
FRONT AXLE AND WHEEL	01077	REAR WHEEL (13.6-16)	100K0350	
	01079	FRONT WHEEL HUB [2WD]	100K0350	
	01080	STEERING LINKAGE [2WD]	100K0350	
	01081	FRONT AXLE [2WD]	100K0350	
	01082	MISSION COVER [2WD]	100K0350	
	01087	DIFFERENTIAL CASE [4WD]	100K0350	
	01088	BEVEL GEAR CASE [4WD]	100K0350	
	01089	AXLE CASE [4WD]	100K0350	
	01090	KNUCKLE ARM [4WD]	100K0350	
	01091	DRIVE CASE [4WD]	100K0350	
	01092	FRONT AXLE BRACKET [4WD]	100K0350	
	01093	FRONT AXLE SUPPORT [4WD]	100K0350	
	01094	STEERING LINKAGE [4WD]	100K0350	
	01095	PROPELLER SHAFT [4WD]	100K0350	
	POSITION AND DRAFT CONTROL	01099	POSITION CONTROL	100K0350
		01100	DRAFT CONTROL	100K0350
		01101	DRAFT CONTROL VALVE SECTION PARTS	100K0350
		01102	TOP LINK HOLDER	100K0350
MANUAL STEERING	01103	STEERING [2WD]	100K0350	
	01104	STEERING SECTION PARTS [2WD]	100K0350	
	01105	RELIEF VALVE [2WD]	100K0350	
	01106	STEERING [4WD]	100K0350	
	01107	STEERING SECTION PARTS [4WD]	100K0350	
	01108	RELIEF VALVE [4WD]	100K0350	
INTEGRAL POWER STEERING	01115	POWER STEERING [4WD]	100K0350	
	01116	FLOW PRIORITY VALVE [4WD]	100K0350	
	01117	DRAG LINK [2WD]	100K0350	
CLUTCH	01119	DRAG LINK [4WD]	100K0350	
	01120	CLUTCH HOUSING	100K0350	
	01121	MAIN SHAFT	100K0350	
	01122	SPEED CHANGE SYSTEM	100K0350	
	01123	CLUTCH HOUSING	100K0350	
	01124	GEAR CASE	100K0350	
	01125	PTO COUNTER SHAFT	100K0350	
	01126	PTO GEAR CASE	100K0350	
HITCH AND SWING DRAWBAR	01128	PTO SHIFT FORK	100K0350	
RESTRICT AND SEAT	01129	HITCH	100K0350	
	01131	MAIN SPEED CHANGE GUIDE	100K0350	

Item	Part No.	Description	Book
RESTRICT AND SEAT	01132	SEAT	100K0350
LAMP AND S.M.V. EMBLEM	01133	TAIL LAMP	100K0350
	01134	HAZARD LAMP	100K0350
	01135	S.M.V.EMBLEM BRACKET	100K0350
FENDER	01136	FENDER	100K0350
	01137	BALUSTRADE	100K0350
AIR CLEANER AND MUFFLER	01138	AIR CLEANER	100K0350
	01140	UPPER MUFFLER [4WD]	100K0350
	01141	UNDER MUFFLER	100K0350
LABEL	01142	LABEL	100K0350
INTEGRAL POWER STEERING	01143	DIFFERENTIAL CASE [4WD (INTEGRAL POWER STEERING)]	100K0350
	01144	BEVEL GEAR CASE [4WD (INTEGRAL POWER STEERING)]	100K0350
	01145	AXLE CASE [4WD (INTEGRAL POWER STEERING)]	100K0350
	01146	KNUCKLE ARM [4WD (INTEGRAL POWER STEERING)]	100K0350
	01147	DRAG LINK [4WD (INTEGRAL POWER STEERING)]	100K0350
	01148	DRIVE CASE [4WD (INTEGRAL POWER STEERING)]	100K0350
	01149	FRONT AXLE BRACKET [4WD (INTEGRAL POWER STEERING)]	100K0350

CRANKCASE

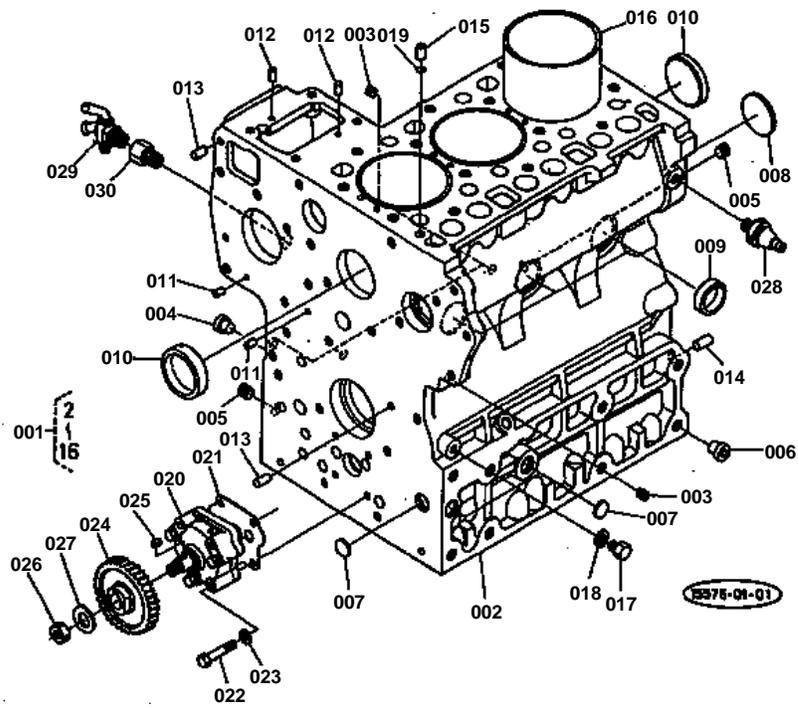



CRANKCASE

↔ Interchangeable; ≠ not interchangeable; ← new for old; → old for new

REF.No	Part No.	Description	Q'ty	S.No.	I/C	REMARKS	Weight (kgf)	Weight (lb)
001	15575-01010	ASSY CRANKCASE	1				45	99
002	99999-99999	BLANK	1			ORDER BY REF.No.001	0	0
002	99999-99999	BLANK	0			ORDER BY REF.No.001	0	0
003	15521-96020	PLUG	5				0.003	0.0066
004	34150-27580	PLUG	1				0.001	0.0022
005	15521-96030	PLUG	2				0.007	0.0154
006	32210-27580	PLUG	8				0.001	0.0022
007	06311-75015	PLUG,EXPANSION	3				0.002	0.0044
008	06311-75045	PLUG,EXPANSION	1				0.026	0.0572
009	15221-03380	CAP,SEALING	5				0.017	0.0374
010	15221-03390	CAP,SEALING	2				0.03	0.066
011	05012-00408	PIN,STRAIGHT	2				0.001	0.0022
012	05012-00609	PIN,STRAIGHT	2				0.003	0.0066
013	05012-00612	PIN,STRAIGHT	2				0.003	0.0066
014	05012-01018	PIN,STRAIGHT	3				0.012	0.0264
015	15221-33650	PIN,PIPE	1				0.004	0.0088
016	15221-02310	LINER,CYLINDER	3				0.58	1.276
017	15221-33610	PLUG	1				0.009	0.0198
018	15021-33660	GASKET	1				0.001	0.0022
019	15221-33700	O RING	1				0.001	0.0022
020	15321-35010	ASSY PUMP,OIL	1				0.525	1.155
021	15221-35150	GASKET,OIL PUMP	1				0	0
022	01053-50648	BOLT	4				0.01	0.022
023	04512-50060	WASHER,SPRING	4				0	0
024	15521-35660	GEAR,OIL PUMP DRIVE	1				0	0
024	19202-35660	GEAR,OIL PUMP DRIVE	1				0.23	0.506
025	05712-00410	KEY,FEATHER	1				0.001	0.0022
026	15221-35680	NUT	1				0	0
027	15221-35670	WASHER	1				0.005	0.011
028	15521-39010	SWITCH,OIL	1				0.048	0.1056
029	14412-73112	COCK,DRAIN	1				0	0
030	15291-73160	JOINT,DRAIN COCK	1				0.04	0.088

OIL PAN

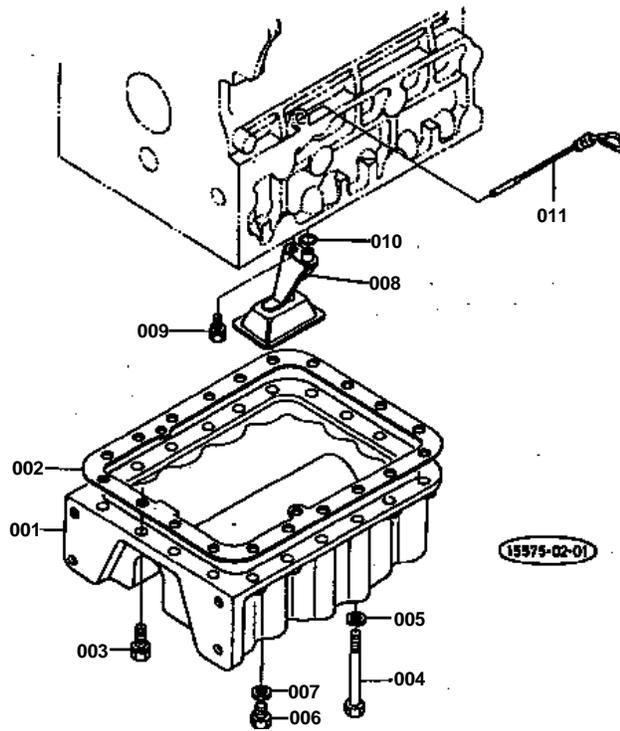



OIL PAN

↔ Interchangeable; ≠ not interchangeable; ← new for old; → old for new

REF.No	Part No.	Description	Q'ty	S.No.	I/C	REMARKS	Weight (kgf)	Weight (lb)
001	15301-01610	OIL PAN	1				11.4	25.08
002	15301-01620	GASKET,OIL PAN	1				0	0
003	01133-51035	BOLT	16				0.03	0.066
004	15411-91010	BOLT	4				0	0
005	04512-50100	WASHER,SPRING	4				0	0
006	15221-33750	PLUG	2				0.032	0.0704
007	15109-33660	GASKET	2				0.001	0.0022
008	15301-32110	FILTER,OIL	1				0.23	0.506
009	01123-50814	BOLT	1				0	0
010	04811-00140	O RING	1				0.001	0.0022
011	19222-36410	GAUGE,OIL	1				0.04	0.088

CYLINDER HEAD

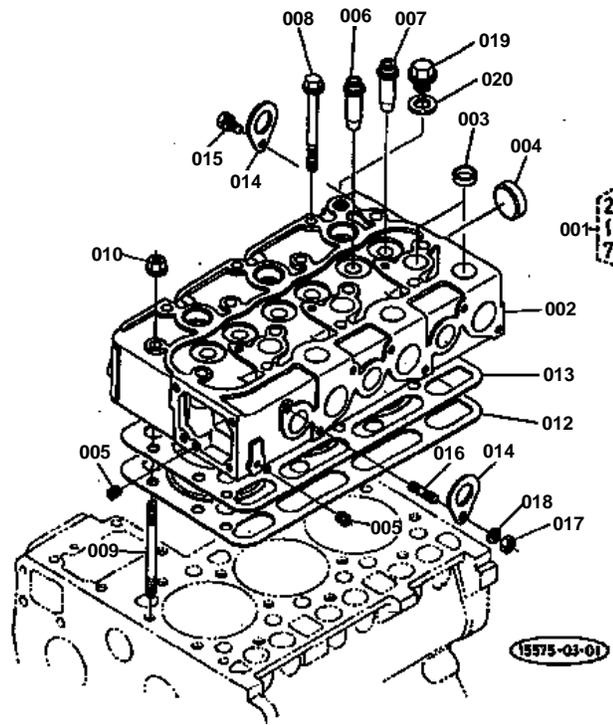



CYLINDER HEAD

↔ Interchangeable; ≠ not interchangeable; ← new for old; → old for new

REF.No	Part No.	Description	Q'ty	S.No.	I/C	REMARKS	Weight (kgf)	Weight (lb)
001	15501-03040	ASSY CYLINDER HEAD	1				15	33
002	99999-99999	BLANK	1			ORDER BY REF.No.001	0	0
002	99999-99999	BLANK	0			ORDER BY REF.No.001	0	0
003	15221-03370	CAP,SEALING	9				0.01	0.022
004	15221-03490	CAP,SEALING	1				0.02	0.044
005	15261-96010	PLUG	2				0.002	0.0044
006	15221-13580	GUIDE,VALVE	3				0	0
007	15601-13560	GUIDE,EXHAUST VALVE	3				0	0
008	19202-03450	BOLT,HEAD	12				0.065	0.143
009	19202-03410	STUD,HEAD	2				0.065	0.143
010	19202-03510	NUT,HEAD	2				0.012	0.0264
011	99999-99999	BLANK	0				0	0
012	15321-03310	GASKET,HEAD	1				0	0
013	15321-03320	SHIM,HEAD GASKET	1				0.047	0.1034
014	15221-01750	HOOK,ENGINE	2				0.04	0.088
015	01123-50816	BOLT	1				0.011	0.0242
016	15521-91490	STUD	1				0	0
017	02156-50080	NUT	1				0.004	0.0088
018	04512-50080	WASHER,SPRING	1				0.001	0.0022
019	15000-36080	PLUG	1				0.03	0.066
020	04717-01600	WASHER,SEAL	1				0.003	0.0066

GEAR CASE

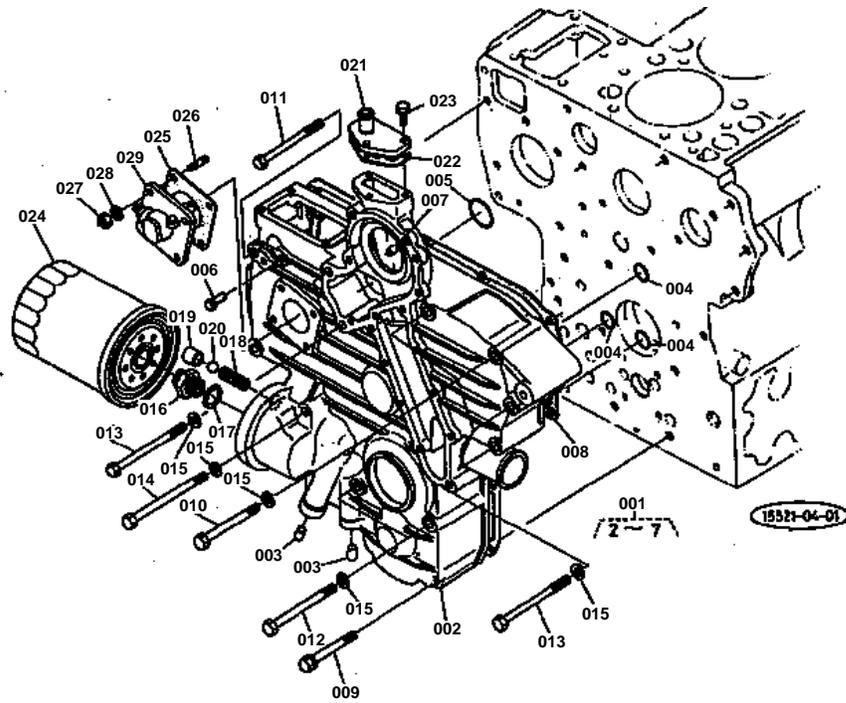



GEAR CASE

↔ Interchangeable; ≠ not interchangeable; ← new for old; → old for new

REF.No	Part No.	Description	Q'ty	S.No.	I/C	REMARKS	Weight (kgf)	Weight (lb)
001	15521-04020	ASSY CASE,GEAR	1				0	0
002	99999-99999	BLANK	1			ORDER BY REF.No.001	0	0
003	15521-33630	PLUG,PIN	2				0.003	0.0066
004	04811-00150	O RING	3				0.001	0.0022
005	04811-00360	O RING	1				0.002	0.0044
006	15221-56280	PIN,START SPRING	1				0.006	0.0132
007	05012-00612	PIN,STRAIGHT	2				0.003	0.0066
008	15521-04130	GASKET,GEAR CASE	1				0	0
009	01123-50860	BOLT	2				0.026	0.0572
010	01153-50870	BOLT	5				0.026	0.0572
011	15521-91010	BOLT	1				0	0
012	01153-50880	BOLT	2				0.03	0.066
013	15521-91020	BOLT	3				0.035	0.077
014	01153-50895	BOLT	2				0.035	0.077
015	04512-50080	WASHER,PLAIN	13				0.001	0.0022
016	15521-32290	JOINT,PIPE	1				0.05	0.11
017	04011-50180	WASHER,PLAIN	1				0.012	0.0264
018	15241-36950	SPRING	1				0.004	0.0088
019	15521-36930	SEAT,VALVE	1				0.015	0.033
020	07715-03213	BALL	1				0.004	0.0088
021	15521-73320	FLANGE,WATER RETURN	1				0.04	0.088
022	15521-73330	GASKET,WATER RETURN	1				0	0
023	01023-50620	BOLT	3				0.006	0.0132
024	15521-32430	CARTRIDGE,OIL FILTER	1				0	0
025	15221-88130	GASKET,HOUR METER	1				0	0
026	15221-88210	STUD	4				0.005	0.011
027	02056-50060	NUT	4				0.002	0.0044
028	04512-50060	WASHER,SPRING	4				0	0
029	38240-34660	ASSY GEAR CASE,HOUR	1				0.335	0.737

MAIN BEARING CASE

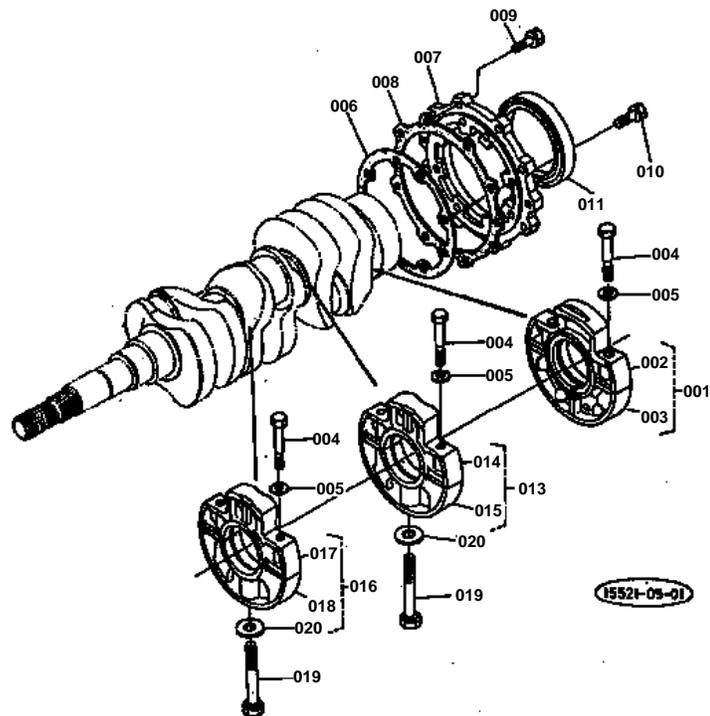



MAIN BEARING CASE

↔ Interchangeable; ≠ not interchangeable; ← new for old; → old for new

REF.No	Part No.	Description	Q'ty	S.No.	I/C	REMARKS	Weight (kgf)	Weight (lb)
001	15521-04040	ASSY CASE,MAIN BEARI	1				0	0
002	99999-99999	BLANK	1			ORDER BY REF.No.001	0	0
003	99999-99999	BLANK	1			ORDER BY REF.No.001	0	0
004	15521-04540	BOLT,BEARING CASE	6				0	0
005	15521-94010	WASHER,PLAIN	6				0.001	0.0022
006	15221-04360	GASKET	1				0	0
007	15221-04810	COVER,BEARING	1	<=2234			0.3	0.66
007	19202-04810	COVER,BEARING	1	>=2235			0.36	0.792
008	15221-04820	GASKET	1				0	0
009	01123-50825	BOLT	8				0.013	0.0286
010	01123-50828	BOLT	8				0.014	0.0308
011	15221-04460	SEAL,OIL	1	<=2234			0.06	0.132
011	19202-04460	SEAL,OIL	1	>=2235			0.055	0.121
012	99999-99999	BLANK	0				0	0
013	15521-04050	ASSY CASE,MAIN BEARI	1				0	0
014	99999-99999	BLANK	1			ORDER BY REF.No.013	0	0
015	99999-99999	BLANK	1			ORDER BY REF.No.013	0	0
016	15521-04060	ASSY CASE,MAIN BEARI	1				0	0
017	99999-99999	BLANK	1			ORDER BY REF.No.016	0	0
018	99999-99999	BLANK	1			ORDER BY REF.No.016	0	0
019	15291-04560	BOLT, 2	2				0.06	0.132
020	15521-94020	WASHER,PLAIN	2				0.004	0.0088

INLET AND EXHAUST MANIFOLD

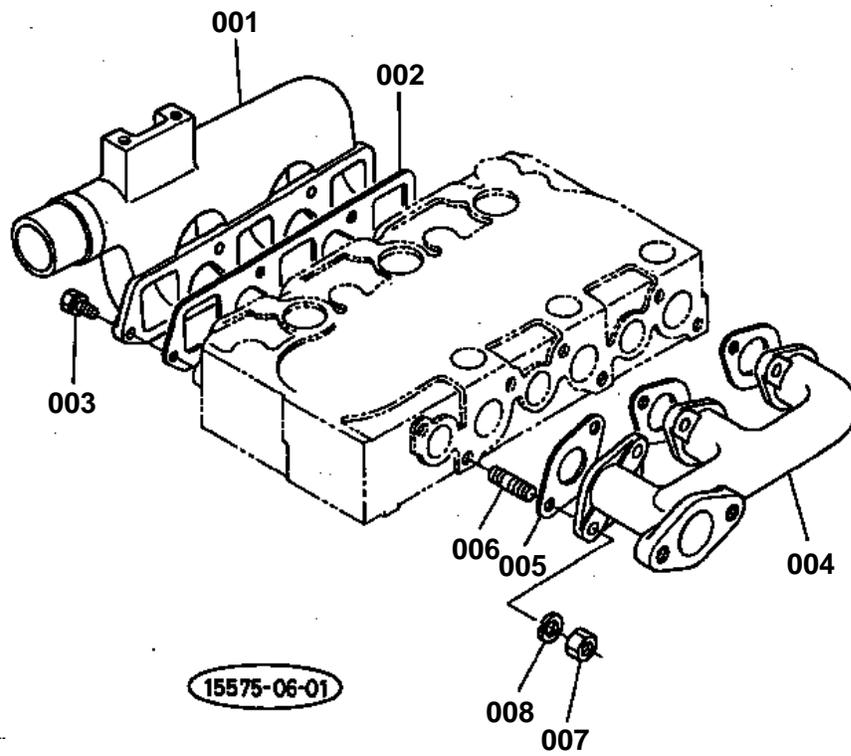



INLET AND EXHAUST MANIFOLD

↔ Interchangeable; ≠ not interchangeable; ← new for old; → old for new

REF.No	Part No.	Description	Q'ty	S.No.	I/C	REMARKS	Weight (kgf)	Weight (lb)
001	15501-11760	MANIFOLD,INLET	1				0.75	1.65
002	15521-11820	GASKET,INLET MANIFOL	1				0	0
003	01123-50822	BOLT	5				0.012	0.0264
004	15321-12310	MANIFOLD,EXHAUST	1				1.46	3.212
005	15521-12350	GASKET,EXHAUST MANIF	3				0	0
006	15221-91530	STUD	6				0.011	0.0242
007	02156-50080	NUT	6				0.004	0.0088
008	04512-50080	WASHER,SPRING	6				0.001	0.0022

VALVE AND ROCKER ARM

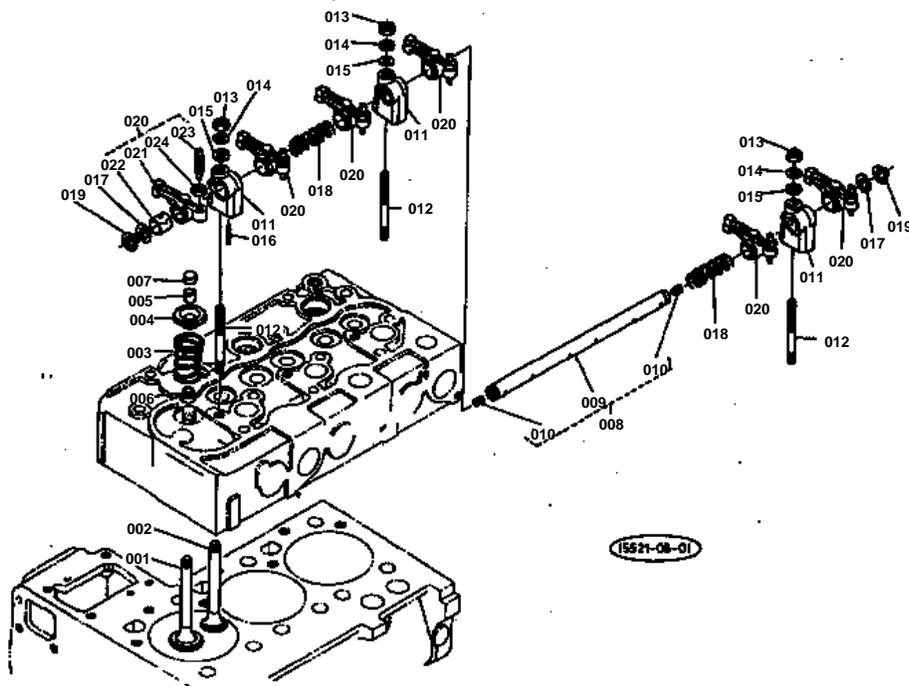



VALVE AND ROCKER ARM

↔ Interchangeable; ≠ not interchangeable; ← new for old; → old for new

REF.No	Part No.	Description	Q'ty	S.No.	I/C	REMARKS	Weight (kgf)	Weight (lb)
001	15221-13110	VALVE,INLET	3				0.062	0.1364
002	15221-13120	VALVE,EXHAUST	3				0.054	0.1188
003	15221-13240	SPRING,VALVE	6				0.036	0.0792
004	15221-13330	RETAINER,VALVE SPRIN	6				0.03	0.066
005	15221-13360	COLLET,VALVE SPRING	12				0	0
006	15221-13150	SEAL,VALVE STEM	6				0.001	0.0022
007	15221-13280	CAP,VALVE	6				0.006	0.0132
008	15321-14050	ASSY SHAFT,ROCKER AR	1				0.25	0.55
009	99999-99999	BLANK	1			ORDER BY REF.No.008	0	0
010	03410-50808	SCREW,SET	2				0	0
011	15221-14350	BRACKET,ROCKER ARM	3				0.044	0.0968
012	15521-91500	STUD	3				0.035	0.077
013	02156-50080	NUT	3				0.004	0.0088
014	04512-50080	WASHER,SPRING	3				0.001	0.0022
015	04012-50080	WASHER,PLAIN	3				0.001	0.0022
016	15221-14420	SCREW,SET	1				0.003	0.0066
017	15221-14430	WASHER	2				0.002	0.0044
018	15221-14310	SPRING,ROCKER ARM	2				0.005	0.011
019	04612-00140	CIR-CLIP,EXTERNAL	2				0.001	0.0022
020	15601-14030	ASSY ROCKER ARM	6				0	0
021	99999-99999	BLANK	6			ORDER BY REF.No.020	0	0
022	15221-14180	BUSH,ROCKER ARM	6				0.007	0.0154
023	15521-14230	SCREW,ADJUSTING	6				0.009	0.0198
024	15021-14240	NUT	6				0.003	0.0066

HEAD COVER

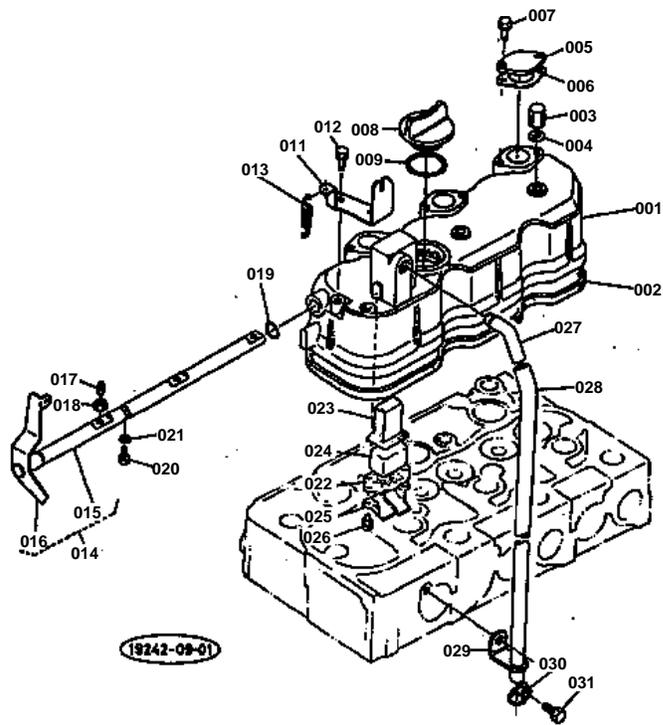



HEAD COVER

↔ Interchangeable; ≠ not interchangeable; ← new for old; → old for new

REF.No	Part No.	Description	Q'ty	S.No.	I/C	REMARKS	Weight (kgf)	Weight (lb)
001	15521-14510	COVER,CYLINDER HEAD	1				1.22	2.684
002	15521-14520	GASKET,HEAD COVER	1				0.035	0.077
003	15451-92330	NUT,CAP	3				0.015	0.033
004	15021-33660	GASKET	3				0.001	0.0022
005	15221-66630	COVER,DECOMP.HOLE	3				0.035	0.077
006	15221-66640	GASKET,COVER	3				0	0
007	01023-50614	BOLT	6				0.005	0.011
008	15221-33140	PLUG,OIL FILLER	1				0.038	0.0836
009	04811-50300	O RING	1				0.001	0.0022
010	99999-99999	BLANK	0				0	0
011	15221-66190	HOLDER,DECOMP.WIRE	1				0.055	0.121
012	01023-50614	BOLT	2				0.005	0.011
013	15221-66280	SPRING,DECOMPRESS	1				0.008	0.0176
014	15521-66040	ASSY SHAFT,DECOMPRES	1				0.385	0.847
015	99999-99999	BLANK	1			ORDER BY REF.No.014	0	0
016	99999-99999	BLANK	1			ORDER BY REF.No.014	0	0
017	15221-66350	BOLT,DECOMPRESS	3				0.005	0.011
018	15221-66360	NUT,DECOMPRESS	3				0.003	0.0066
019	04811-06100	O RING	1				0.001	0.0022
020	15221-66410	BOLT	1				0.005	0.011
021	04512-50060	WASHER,SPRING	1				0	0
022	15521-05140	PLATE,BREATHER ELEME	1				0.005	0.011
023	15521-05150	PLATE,BREATHER ELEME	1				0.01	0.022
024	15521-05670	ELEMENT,BREATHER	1				0.01	0.022
025	15521-05370	OIL SEIELD,BREATHER	1				0.005	0.011
026	15521-93310	SCREW	2				0.004	0.0088
027	15521-05550	JOINT,BREATHER PIPE	1				0.04	0.088
028	15521-05510	PIPE,BREATHER	1				0.075	0.165
029	15401-05580	CLAMP,PIPE	1				0.02	0.044
030	15341-05590	CLAMP,PIPE	1				0.003	0.0066
031	01173-51220	BOLT	1				0.03	0.066

CAMSHAFT

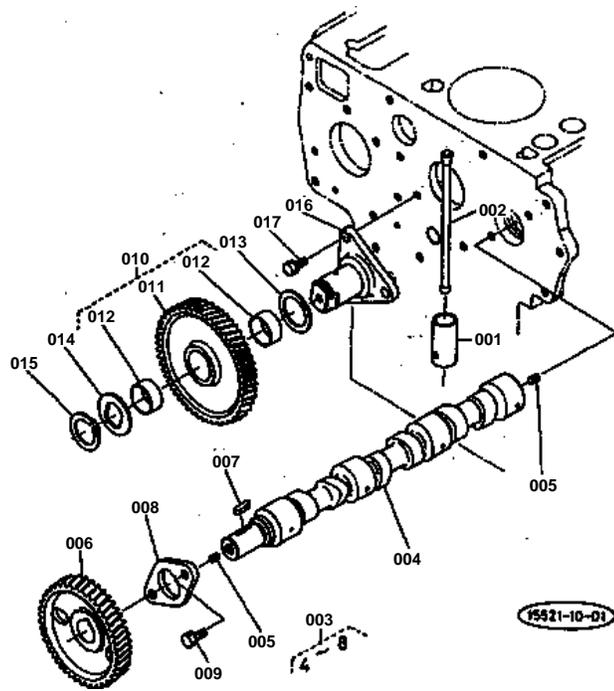



CAMSHAFT

↔ Interchangeable; ≠ not interchangeable; ← new for old; → old for new

REF.No	Part No.	Description	Q'ty	S.No.	I/C	REMARKS	Weight (kgf)	Weight (lb)
001	15221-15550	TAPPET	6				0	0
002	15221-15110	ROD,PUSH	6				0.05	0.11
003	15521-16010	ASSY CAMSHAFT	1				3.6	7.92
004	99999-99999	BLANK	1			ORDER BY REF.No.003	0	0
005	15521-93610	SCREW,SET	2				0.002	0.0044
006	15521-16510	GEAR,CAMSHAFT	1				0.85	1.87
007	05712-00720	KEY,FEATHER	1				0.008	0.0176
008	15221-16270	STOPPER,CAMSHAFT	1				0.073	0.1606
009	01123-50818	BOLT	2				0.012	0.0264
010	15221-24010	ASSY,GEAR,IDLE	1				0.5	1.1
011	99999-99999	BLANK	1			ORDER BY REF.No.010	0	0
012	15221-24980	BUSH,IDLE GEAR	2				0.02	0.044
013	15521-24360	COLLAR 1	1				0.015	0.033
014	15521-24370	COLLAR 2	1				0.015	0.033
015	15221-24320	CIR-CLIP,EXTERNAL	1				0.01	0.022
016	15221-24250	SHAFT,IDLE GEAR	1				0.48	1.056
017	01123-50818	BOLT	3				0.012	0.0264

PISTON AND CRANKSHAFT

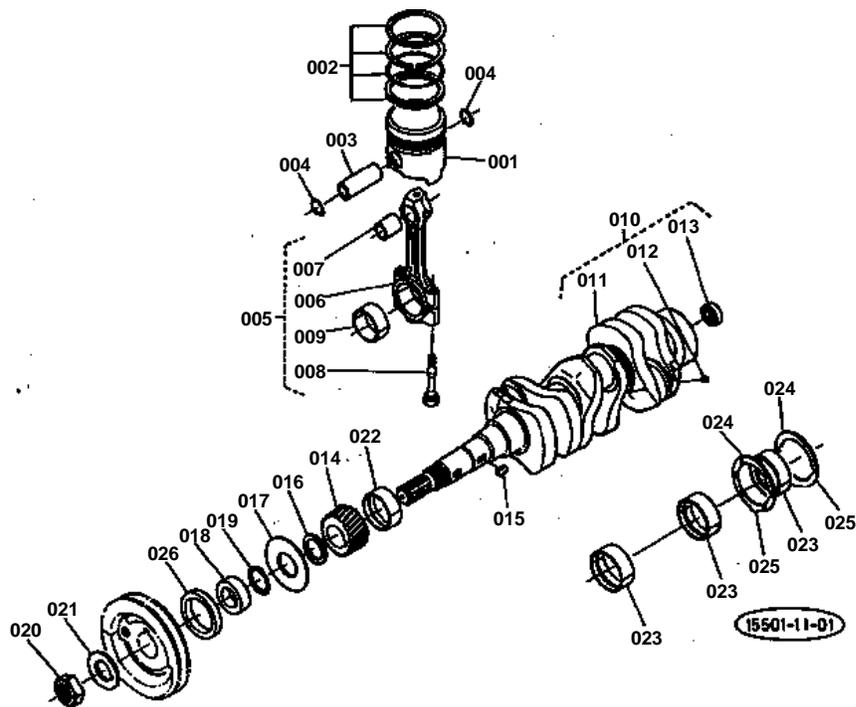



PISTON AND CRANKSHAFT

↔ Interchangeable; ≠ not interchangeable; ← new for old; → old for new

REF.No	Part No.	Description	Q'ty	S.No.	I/C	REMARKS	Weight (kgf)	Weight (lb)
001	15221-21110	PISTON	3			STD	0.45	0.99
001	15221-21910	PISTON	3			+0.5	0.452	0.9944
002	15501-21050	ASSY PISTON RING	3			STD	0.05	0.11
002	15501-21090	ASSY PISTON RING	3			+0.5	0.05	0.11
003	15521-21310	PIN,PISTON	3				0.156	0.3432
004	15221-21330	CIR-CLIP,PISTON PIN	6				0.002	0.0044
005	15521-22010	ASSY ROD,CONNECTING	3				0	0
006	99999-99999	BLANK	3			ORDER BY REF.No.005	0	0
007	15221-21980	BUSH,PISTON PIN	3				0	0
008	15521-22140	BOLT,CONNECTING ROD	6				0	0
009	15221-22310	METAL,CRANK PIN	6			STD	0	0
009	15221-22970	METAL,CRANK PIN	6			-0.2	0.04	0.088
009	15221-22980	METAL,CRANK PIN	6			-0.4	0.04	0.088
010	15501-23010	ASSY CRANKSHAFT	1	<=2234			13.42	29.524
010	15568-23010	ASSY CRANKSHAFT	1	>=2235			13.04	28.688
011	99999-99999	BLANK	1			ORDER BY REF.No.010	0	0
012	15221-33630	PLUG,PIN	3				0.001	0.0022
013	08121-06002	BEARING,BALL	1				0.03	0.066
014	15521-24110	GEAR,CRANKSHAFT	1				0.34	0.748
015	05712-00720	KEY,FEATHER	1				0.008	0.0176
016	15221-24130	COLLAR,CRANK-GEAR	1				0.015	0.033
017	15221-23310	OIL SLINGER	1				0	0
018	15221-23250	COLLAR,CRANKSHAFT	1	<=2234			0	0
018	19202-23250	COLLAR,CRANKSHAFT	1	>=2235			0.065	0.143
019	04811-10300	O RING	1				0.001	0.0022
020	15221-23360	NUT,CRANKSHAFT	1				0.11	0.242
021	15221-23380	WASHER,CRANKSHAFT	1				0.02	0.044
022	15221-23470	METAL,CRANKSHAFT 1	1			STD	0	0
022	15221-23910	METAL,CRANKSHAFT 1	1			-0.2	0.058	0.1276
022	15221-23920	METAL,CRANKSHAFT 1	1			-0.4	0	0
023	15221-23480	METAL,CRANKSHAFT 2	6			STD	0	0
023	15221-23930	METAL,CRANKSHAFT 2	6			-0.2	0.055	0.121
023	15221-23940	METAL,CRANKSHAFT 2	6			-0.4	0.056	0.1232
024	15521-23530	METAL,SIDE 1	2			STD	0.01	0.022
024	15221-23950	METAL,SIDE 1	2			+0.2	0	0
024	15221-23960	METAL,SIDE 1	2			+0.4	0.009	0.0198
025	15521-23540	METAL,SIDE 2	2			STD	0	0
025	15221-23970	METAL,SIDE 2	2			+0.2	0.009	0.0198
025	15221-23980	METAL,SIDE 2	2			+0.4	0.009	0.0198
026	09550-00001	SEAL,OIL	1				0.015	0.033



FLYWHEEL (SINGLE CLUTCH)

↔ Interchangeable; ≠ not interchangeable; ← new for old; → old for new

REF.No	Part No.	Description	Q'ty	S.No.	I/C	REMARKS	Weight (kgf)	Weight (lb)
001	15331-25010	ASSY FLYWHEEL	1	>=10001			0	0
001	15521-25010	ASSY FLYWHEEL	1	>=10001			0	0
002	99999-99999	BLANK	1			ORDER BY REF.No.001	0	0
003	15221-63820	GEAR,RING	1	<=10454		(2WD)	1.2	2.64
003	15221-63823	GEAR,RING	1	>=10455		(2WD)	0	0
003	15221-63820	GEAR,RING	1	<=10431		(4WD)	1.2	2.64
003	15221-63823	GEAR,RING	1	>=10432		(4WD)	0	0
004	15321-25160	BOLT,FLYWHEEL	6	<=10454		(2WD)	0.05	0.11
004	15521-25160	BOLT,FLYWHEEL	6	>=10455		(2WD)	0.06	0.132
004	15321-25160	BOLT,FLYWHEEL	6	<=10431		(4WD)	0.05	0.11
004	15521-25160	BOLT,FLYWHEEL	6	>=10432		(4WD)	0.06	0.132
005	15321-25170	WASHER,FLYWHEEL	3	<=10454		(2WD)	0.01	0.022
005	15521-25170	WASHER,FLYWHEEL	3	>=10455		(2WD)	0.06	0.132
005	15321-25170	WASHER,FLYWHEEL	3	<=10431		(4WD)	0.01	0.022
005	15521-25170	WASHER,FLYWHEEL	3	>=10432		(4WD)	0.06	0.132
006	15521-04600	ASSY HOUSING, FLYWHEEL	1				5	11
007	99999-99999	BLANK	1			ORDER BY REF.No.006	0	0
008	05012-01025	PIN,STRAIGHT	2				0.016	0.0352
009	31220-14290	PLUG	10				0.002	0.0044
010	15521-04680	COVER	1				0.035	0.077
011	01123-50816	BOLT	2				0.011	0.0242
012	15521-04790	GASKET	1				0.005	0.011
013	01073-51030	BOLT	11				0.028	0.0616
014	04512-50100	WASHER,SPRING	11				0	0
015	01073-51240	BOLT	2				0.049	0.1078
016	04512-50120	WASHER,SPRING	2				0	0
017	15321-63010	ASSY STARTER	1				0	0
018	01133-51030	BOLT	1				0.025	0.055
019	01517-51028	STUD	1				0.022	0.0484
020	02176-50100	NUT	1				0.005	0.011
021	04512-50100	WASHER,SPRING	1				0	0

FLYWHEEL (DUAL CLUTCH)

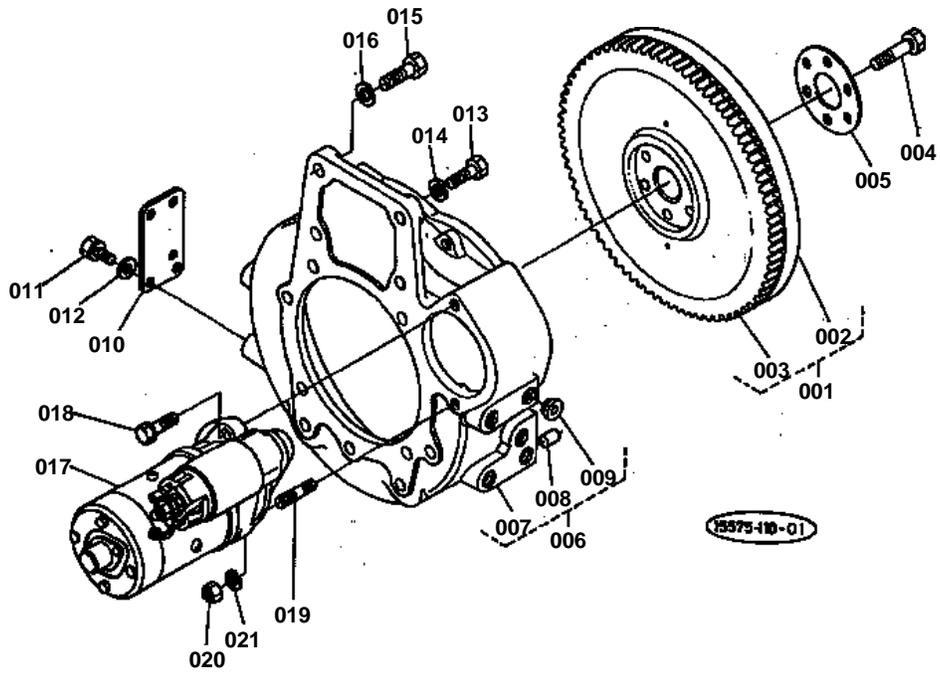



FLYWHEEL (DUAL CLUTCH)

↔ Interchangeable; ≠ not interchangeable; ← new for old; → old for new

REF.No	Part No.	Description	Q'ty	S.No.	I/C	REMARKS	Weight (kgf)	Weight (lb)
001	15525-25010	ASSY FLYWHEEL	1				0	0
002	99999-99999	BLANK	1			ORDER BY REF.No.001	0	0
003	15221-63820	GEAR,RING	1				1.2	2.64
004	15471-25160	BOLT,FLYWHEEL	6				0.05	0.11
005	15521-25170	WASHER,FLYWHEEL	1				0.06	0.132
006	15577-04600	ASSY HOUSING,FLYWHEE	1				15.75	34.65
007	99999-99999	BLANK	1			ORDER BY REF.No.006	0	0
008	05012-01025	PIN,STRAIGHT	2				0.016	0.0352
009	31220-14290	PLUG	5				0.002	0.0044
010	15577-14290	COVER	1				0.23	0.506
011	01170-51420	BOLT	5				0.04	0.088
012	04011-50140	WASHER,PLAIN	5				0.007	0.0154
013	01073-51030	BOLT	11				0.028	0.0616
014	04512-50100	WASHER,SPRING	11				0	0
015	01073-51240	BOLT	2				0.049	0.1078
016	04512-50120	WASHER,SPRING	2				0	0
017	15321-63010	ASSY STARTER	1				0	0
018	01133-51030	BOLT	1				0.025	0.055
019	01517-51028	STUD	1				0.022	0.0484
020	02176-50100	NUT	1				0.005	0.011
021	04512-50100	WASHER,SPRING	1				0	0

STARTER SECTION PARTS

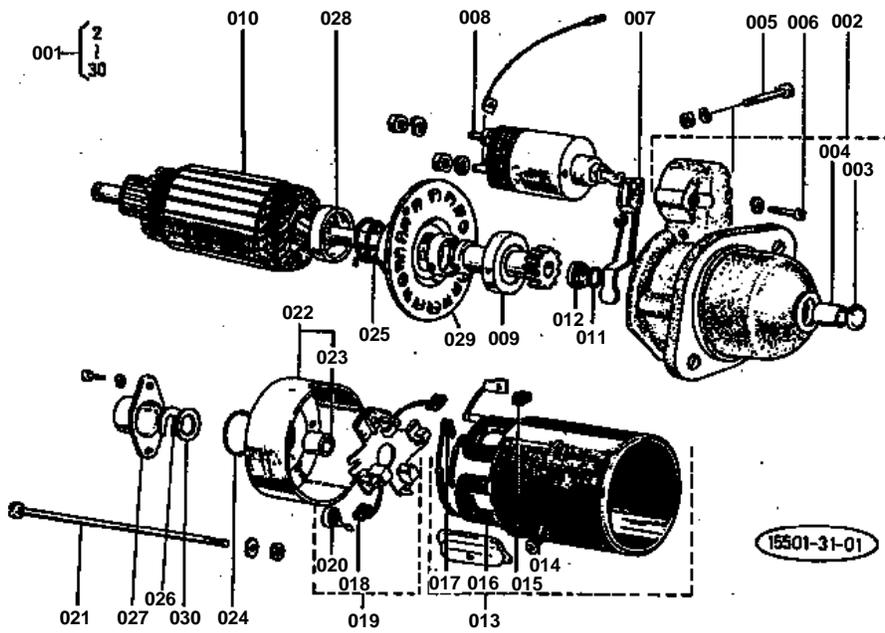



STARTER SECTION PARTS

↔ Interchangeable; ≠ not interchangeable; ← new for old; → old for new

REF.No	Part No.	Description	Q'ty	S.No.	I/C	REMARKS	Weight (kgf)	Weight (lb)
001	15321-63010	ASSY STARTER	1				0	0
002	15321-63030	DRIVE END FRAME	1				1.47	3.234
003	15321-96160	PLUG,BELCH	1				0.001	0.0022
004	17016-63250	BUSH	1				0.006	0.0132
005	15321-91370	BOLT,SET	1				0	0
006	15221-91020	BOLT	2				0.01	0.022
007	15221-63050	LEVER,DRIVE	1				0.044	0.0968
008	15321-63020	SWITCH,MAGNET	1				0.65	1.43
009	15321-63040	CLUTCH	1				0.314	0.6908
010	15321-63070	ARMATURE	1				2.2	4.84
011	15221-94820	PIN,SNAP	1				0.001	0.0022
012	15321-63230	COLLAR	1				0	0
013	15321-63082	YOKE	1				0	0
014	15221-91380	BOLT,SET	2				0.008	0.0176
014	15321-91390	BOLT,SET	2				0.009	0.0198
015	15321-96680	GASKET	1				0.004	0.0088
016	15321-63090	COIL,FIELD	1				0.64	1.408
017	15321-63370	BRUSH	2				0.008	0.0176
018	15321-63360	BRUSH	2				0.008	0.0176
019	15321-63380	HOLDER,BRUSH	1				0.103	0.2266
020	15221-63390	SPRING,BRUSH	4				0.003	0.0066
021	15341-63320	BOLT,THROUGH	2				0.035	0.077
022	15321-63200	END FRAME	1				0.28	0.616
023	15221-63250	BUSH	1				0.006	0.0132
023	15321-63970	BUSH	1				0.006	0.0132
023	15321-63980	BUSH	1				0.006	0.0132
024	15221-96670	GASKET	1				0.001	0.0022
025	15321-63490	SPRING,RETURN	1				0.006	0.0132
026	15321-94030	WASHER	1				0.002	0.0044
027	15321-63510	CAP,END FRAME	1				0.01	0.022
028	15321-63480	HOLDER,SPRING	1				0.005	0.011
029	15341-63060	BEARING,CENTER	1				0	0
030	15321-94010	WASHER,PLAIN	1				0.001	0.0022

NOZZLE HOLDER

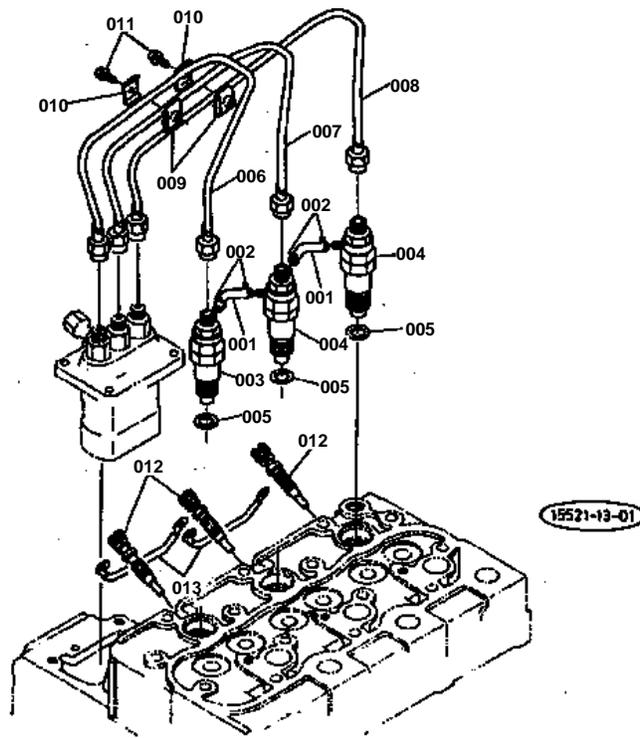



NOZZLE HOLDER

↔ Interchangeable; ≠ not interchangeable; ← new for old; → old for new

REF.No	Part No.	Description	Q'ty	S.No.	I/C	REMARKS	Weight (kgf)	Weight (lb)
001	15221-42510	PIPE,FUEL OVER FLOW	2				0.005	0.011
002	14971-42750	CLIP,PIPE	4				0.001	0.0022
003	15271-53000	ASSY HOLDER,NOZZLE 1	1				0.26	0.572
004	15271-53020	ASSY HOLDER,NOZZLE 2	2				0.26	0.572
005	17011-53620	GASKET	3				0.003	0.0066
006	15221-53710	PIPE,INJECTION	1				0	0
007	15221-53720	PIPE,INJECTION	1				0	0
008	15321-53730	PIPE,INJECTION	1				0	0
009	15121-53850	CLAMP,PIPE	2				0	0
010	15121-53860	CLAMP,PIPE	2				0	0
011	03024-50520	SCREW,WITH WASHER	2				0.004	0.0088
012	15521-65510	GLOW PLUG	3				0.025	0.055
013	15401-65560	CORD,GLOW PLUG	2				0.005	0.011

NOZZLE HOLDER SECTION PARTS

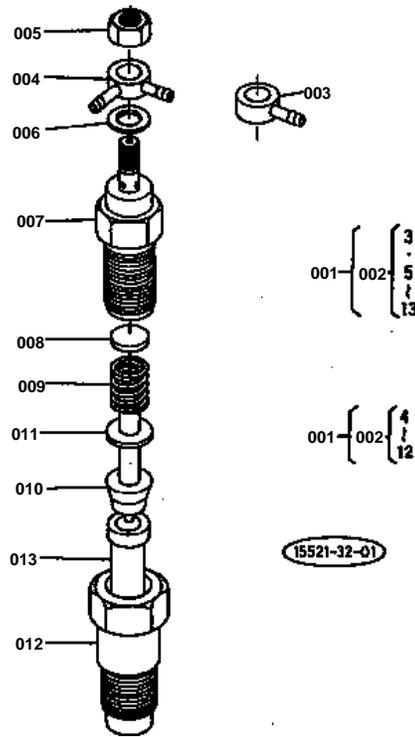



NOZZLE HOLDER SECTION PARTS

↔ Interchangeable; ≠ not interchangeable; ← new for old; → old for new

REF.No	Part No.	Description	Q'ty	S.No.	I/C	REMARKS	Weight (kgf)	Weight (lb)
001	15271-53000	ASSY HOLDER,NOZZLE 1	1				0.26	0.572
001	15271-53020	ASSY HOLDER,NOZZLE 2	2				0.26	0.572
002	99999-99999	BLANK	1			ORDER BY REF.No.001	0	0
002	99999-99999	BLANK	2			ORDER BY REF.No.001	0	0
003	15221-95680	JOINT 1	1				0.021	0.0462
004	15221-95690	JOINT 2	2				0.022	0.0484
005	15221-92020	NUT	3				0.011	0.0242
006	15221-94020	WASHER,PLAIN	3				0.002	0.0044
007	99999-99999	BLANK	3			ORDER BY REF.No.002	0	0
008	15221-53230	WASHER,ADJUSTING	3				0.001	0.0022
009	15221-53170	SPRING,NOZZLE	3				0.01	0.022
010	15221-53160	ROD,PUSH	3				0.003	0.0066
011	15221-53350	PIECE,DISTANCE	3				0.016	0.0352
012	15221-53280	NUT,NOZZLE	3				0.068	0.1496
013	15021-53610	NOZZLE,PIECE	3				0	0

FUEL CAMSHAFT

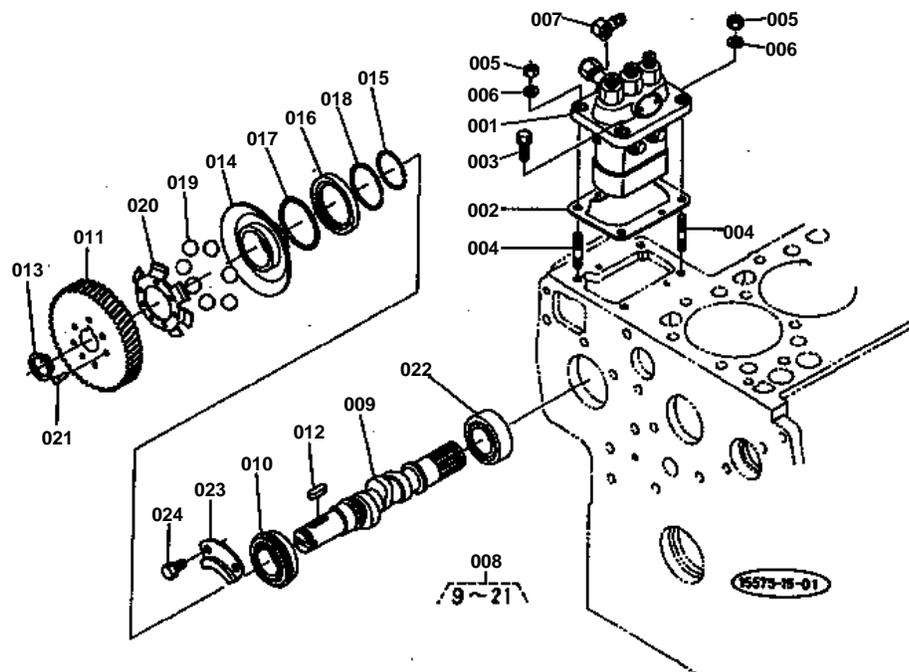



FUEL CAMSHAFT

↔ Interchangeable; ≠ not interchangeable; ← new for old; → old for new

REF.No	Part No.	Description	Q'ty	S.No.	I/C	REMARKS	Weight (kgf)	Weight (lb)
001	15321-51010	ASSY PUMP,INJECTION	1				2	4.4
002	15321-52110	SHIM,INJECTION PUMP	3				0	0
002	15521-52110	SHIM,INJECTION PUMP	3				0.01	0.022
003	01123-50822	BOLT	2				0.012	0.0264
004	01513-50822	STUD	2				0.01	0.022
005	02156-50080	NUT	2				0.004	0.0088
006	04512-50080	WASHER,SPRING	2				0.001	0.0022
007	14111-42410	JOINT,EYE	1				0.025	0.055
008	15521-16020	ASSY CAMSHAFT,FUEL	1				2.23	4.906
009	15521-16170	CAMSHAFT,FUEL	1				0.88	1.936
010	08153-06205	BEARING,BALL	1				0.13	0.286
011	15401-51150	GEAR,INJECTION PUMP	1				0.8	1.76
012	05712-00525	KEY,FEATHER	1				0.005	0.011
013	04612-00240	CIR-CLIP,EXTERNAL	1				0.002	0.0044
014	15221-55450	SLEEVE,GOVERNOR	1				0.19	0.418
015	15221-55470	CIR-CLIP,SLEEVE	1				0.003	0.0066
016	15221-55690	CASE,GOVERNOR BALL	1				0	0
017	07715-03205	BALL	39				0.001	0.0022
018	15221-55740	CIR-CLIP,BALL CASE	1				0.002	0.0044
019	07715-00805	BALL	7				0.016	0.0352
020	15521-55650	GUIDE,GOVERNOR BALL	1				0.035	0.077
021	05611-10310	RIVET	7				0.001	0.0022
022	08103-06205	BEARING,BALL	1				0.12	0.264
023	15221-16320	STOPPER,FUEL CAMSHAF	1				0.02	0.044
024	01123-50814	BOLT	2				0	0

INJECTION PUMP SECTION PARTS

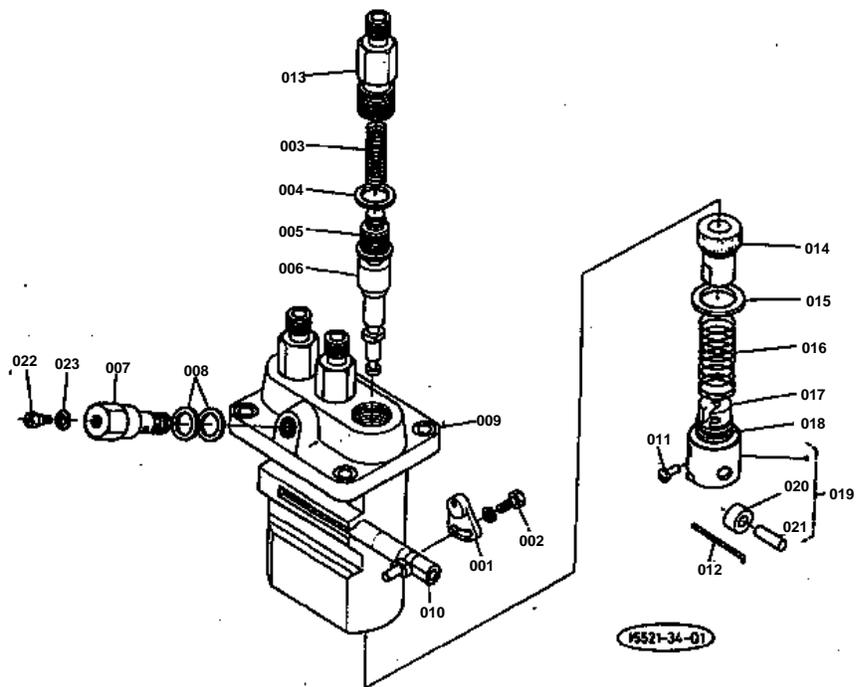



INJECTION PUMP SECTION PARTS

↔ Interchangeable; ≠ not interchangeable; ← new for old; → old for new

REF.No	Part No.	Description	Q'ty	S.No.	I/C	REMARKS	Weight (kgf)	Weight (lb)
001	15221-51390	PLATE,ADJUSTING	2				0	0
002	15221-91030	BOLT	2				0	0
003	15221-51230	SPRING,DELIVERY VALV	3				0.002	0.0044
004	15221-51240	GASKET,DELIVERY VALV	3				0.001	0.0022
005	15221-51030	VALVE,DELIVERY	3				0.012	0.0264
006	15221-51050	ELEMENT,PUMP	3				0.053	0.1166
007	15221-51320	SCREW	1				0.032	0.0704
008	15221-96650	GASKET	2				0.001	0.0022
009	99999-99999	BLANK	1			ORDER BY REF.No.001 ON FIG.No.015	0	0
010	15321-51060	RACK,CONTROL	1				0.038	0.0836
011	15221-51250	PIN,TAPPET GUIDE	3				0.001	0.0022
012	15321-51430	PIN,CLAMP	1				0.001	0.0022
013	15601-51220	HOLDER,DELIVERY VALV	3				0.055	0.121
014	15221-51380	SLEEVE,CONTROL	3				0	0
015	15221-51270	SEAT,SPRING UPPER	2				0.004	0.0088
016	15221-51280	SPRING,PLUNGER	3				0.015	0.033
017	15221-51290	SEAT,SPRING LOWER	3				0.01	0.022
018	15221-51490	SHIM	3				0.002	0.0044
019	15221-51070	ASSY TAPPET	3				0.039	0.0858
020	99999-99999	BLANK	3			ORDER BY REF.No.019	0	0
021	99999-99999	BLANK	3			ORDER BY REF.No.019	0	0
022	15221-51350	SCREW	1				0.008	0.0176
023	15221-96660	GASKET	1				0.002	0.0044

GOVERNOR

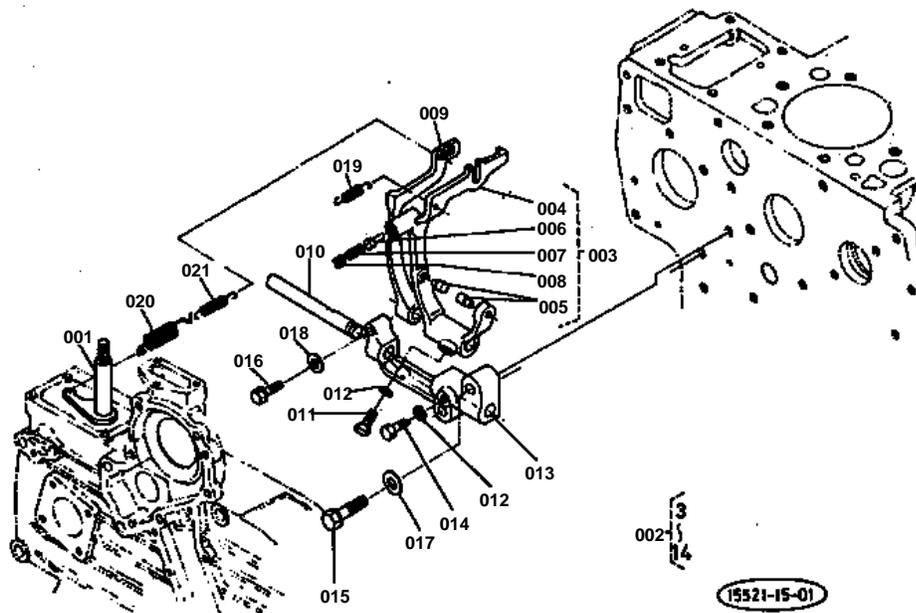

**GOVERNOR**

↔ Interchangeable; ≠ not interchangeable; ← new for old; → old for new

REF.No	Part No.	Description	Q'ty	S.No.	I/C	REMARKS	Weight (kgf)	Weight (lb)
001	15601-56020	ASSY LEVER,GOVERNOR	1				0.055	0.121
002	15521-56050	ASSY LEVER,FORK	1				0.41	0.902
003	15521-56040	ASSY LEVER,FORK	1				0.195	0.429
004	99999-99999	BLANK	1			ORDER BY REF.No.003	0	0
005	99999-99999	BLANK	2			ORDER BY REF.No.003	0	0
006	99999-99999	BLANK	1			ORDER BY REF.No.003	0	0
007	99999-99999	BLANK	1			ORDER BY REF.No.003	0	0
008	99999-99999	BLANK	1			ORDER BY REF.No.003	0	0
009	15611-56130	LEVER,FORK 2	1				0.07	0.154
010	15221-56150	SHAFT,FORK LEVER	1				0.1	0.22
011	15021-56240	BOLT,LEVER SHAFT	1				0.005	0.011
012	04512-50060	WASHER,SPRING	2				0	0
013	15221-56230	HOLDER,FORK LEVER	1				0.1	0.22
014	15221-66410	BOLT	1				0.005	0.011
015	01123-50832	BOLT	2				0.016	0.0352
016	01023-50628	BOLT	1				0.015	0.033
017	04012-50080	WASHER,SPRING	2				0.001	0.0022
018	04012-50060	WASHER,SPRING	1				0.001	0.0022
019	15601-56480	SPRING,START	1				0.002	0.0044
020	15521-56410	SPRING,GOVERNOR 1	1				0	0
021	15521-56420	SPRING,GOVERNOR 2	1				0.002	0.0044

SPEED CONTROL PLATE

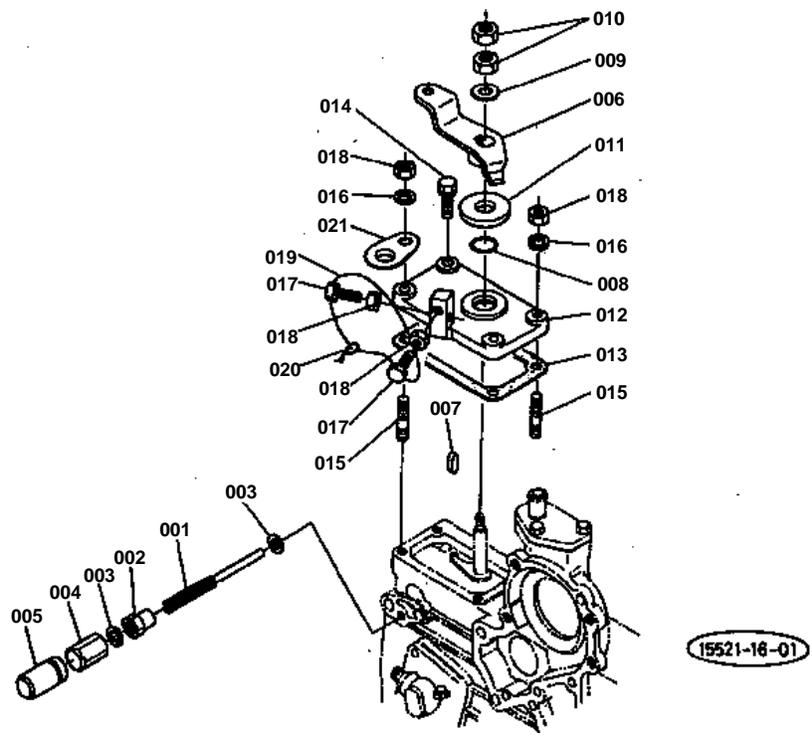



SPEED CONTROL PLATE

↔ Interchangeable; ≠ not interchangeable; ← new for old; → old for new

REF.No	Part No.	Description	Q'ty	S.No.	I/C	REMARKS	Weight (kgf)	Weight (lb)
001	15601-54120	BOLT,ADJUSTING	1				0.011	0.0242
002	15601-92010	NUT	1				0	0
003	15601-96650	GASKET	2				0.001	0.0022
004	15601-54220	NUT,CAP	1				0	0
005	15601-54420	CAP	1				0	0
006	15469-57150	LEVER,SPEED,CONTROL	1				0.06	0.132
007	05712-00408	KEY,FEATHER	1				0.001	0.0022
008	04811-00120	O RING	1				0.001	0.0022
009	04013-50080	WASHER,PLAIN	1				0	0
010	02112-50080	NUT	2				0.003	0.0066
011	17011-57380	PLATE,FRICTION	1				0	0
012	15521-57110	PLATE,SPEED CONTROL	1				0	0
012	15521-57110	PLATE,SPEED CONTROL	1				0	0
012	15521-57113	PLATE,SPEED CONTROL	1	>=1001			0	0
012	15521-57113	PLATE,SPEED CONTROL	1	>=1001			0	0
013	15221-57210	GASKET,CONTROL PLATE	1				0	0
014	01023-50620	BOLT	2				0.006	0.0132
015	15221-88210	STUD	2				0.005	0.011
016	04512-50060	WASHER,SPRING	2				0	0
017	15108-57280	STOPPER	2				0.008	0.0176
018	02056-50060	NUT	4				0.002	0.0044
019	99999-99999	WIRE	1			NON SALE	0	0
020	99999-99999	LEAD,SEALING	1			NON SALE	0	0
021	15521-72730	CLAMP,PIPE	1				0.004	0.0088

ENGINE STOP LEVER

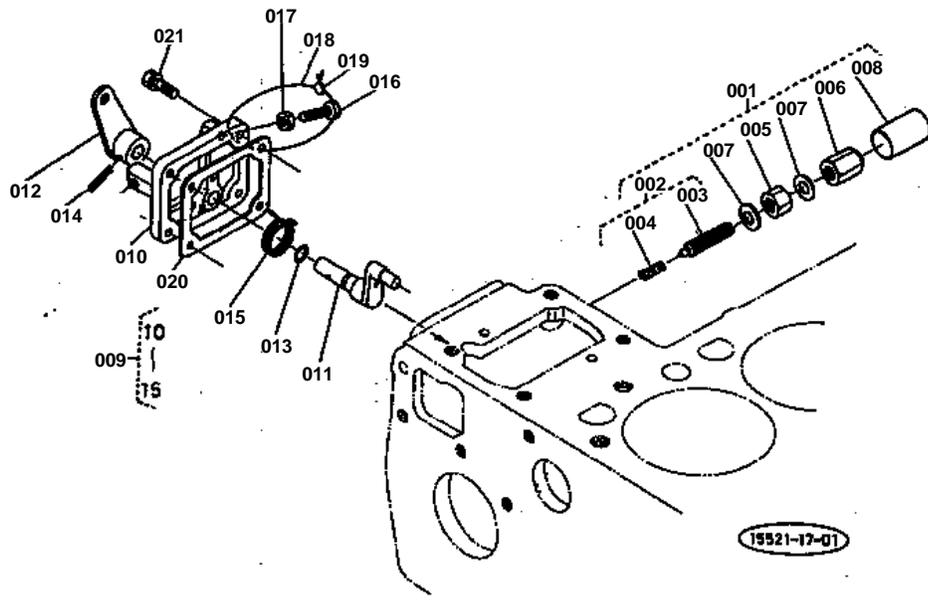



ENGINE STOP LEVER

↔ Interchangeable; ≠ not interchangeable; ← new for old; → old for new

REF.No	Part No.	Description	Q'ty	S.No.	I/C	REMARKS	Weight (kgf)	Weight (lb)
001	15521-54090	ASSY APPARATUS,IDLE	1				0.045	0.099
002	15521-54100	ASSY BOLT,ADJUSTING	1				0.015	0.033
003	99999-99999	BLANK	1			ORDER BY REF.No.002	0	0
004	15521-54260	SPRING	1				0.001	0.0022
005	15401-92010	NUT	1				0.01	0.022
006	15521-92330	NUT,CAP	1				0.02	0.044
007	15021-33660	GASKET	2				0.001	0.0022
008	15521-54270	CAP	1				0.003	0.0066
009	15521-57702	ASSY LEVER,ENGINE ST	1				0	0
010	15521-51650	COVER,INJECTION PUMP	1				0	0
011	99999-99999	BLANK	1			ORDER BY REF.No.009	0	0
012	99999-99999	BLANK	1			ORDER BY REF.No.009	0	0
013	04811-10070	O RING	1				0.001	0.0022
014	05411-00420	PIN,SPRING	1				0.001	0.0022
015	15611-57510	SPRING	1				0.003	0.0066
016	15108-57280	STOPPER	1				0.008	0.0176
017	02056-50060	NUT	1				0.002	0.0044
018	99999-99999	WIRE	1			NON SALE	0	0
019	99999-99999	LEAD,SEALING	1			NON SALE	0	0
020	15221-51660	GASKET,PUMP COVER	1				0	0
021	01023-50618	BOLT	4				0.006	0.0132

DYNAMO

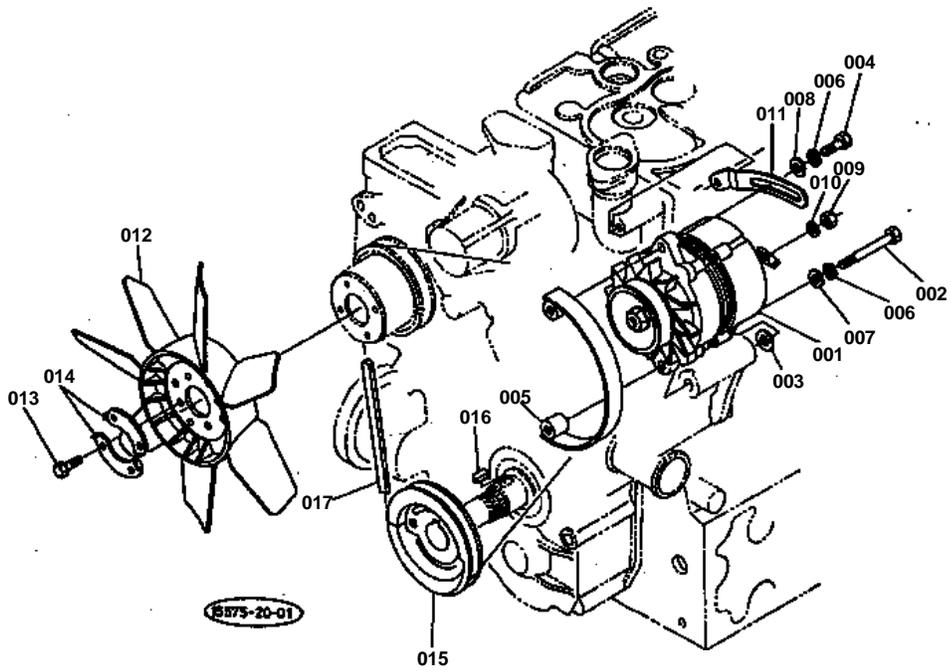

**DYNAMO**

↔ Interchangeable; ≠ not interchangeable; ← new for old; → old for new

REF.No	Part No.	Description	Q'ty	S.No.	I/C	REMARKS	Weight (kgf)	Weight (lb)
001	15411-64010	ASSY DYNAMO	1				3.25	7.15
002	15521-91030	BOLT	1				0	0
003	15521-94030	WASHER,PLAIN	1				0.01	0.022
004	01153-50830	BOLT	1				0	0
005	37300-12940	COVER,DYNAMO	1				0.14	0.308
006	04512-50080	WASHER,SPRING	2				0.001	0.0022
007	04012-50080	WASHER,PLAIN	1				0.001	0.0022
008	04013-50080	WASHER,PLAIN	1				0	0
009	02056-50060	NUT	1				0.002	0.0044
010	04512-50060	WASHER,SPRING	1				0	0
011	15321-64420	STAY,DYNAMO	1				0.1	0.22
012	15585-74110	FAN	1				0.63	1.386
013	01053-50610	BOLT	4				0.004	0.0088
014	15321-74230	WASHER,FAN	2				0.005	0.011
015	15321-74280	PULLEY,FAN DRIVE	1				0	0
016	05712-00720	KEY,FEATHER	1				0.008	0.0176
017	15521-97010	BELT	1				0	0

DYNAMO SECTION PARTS

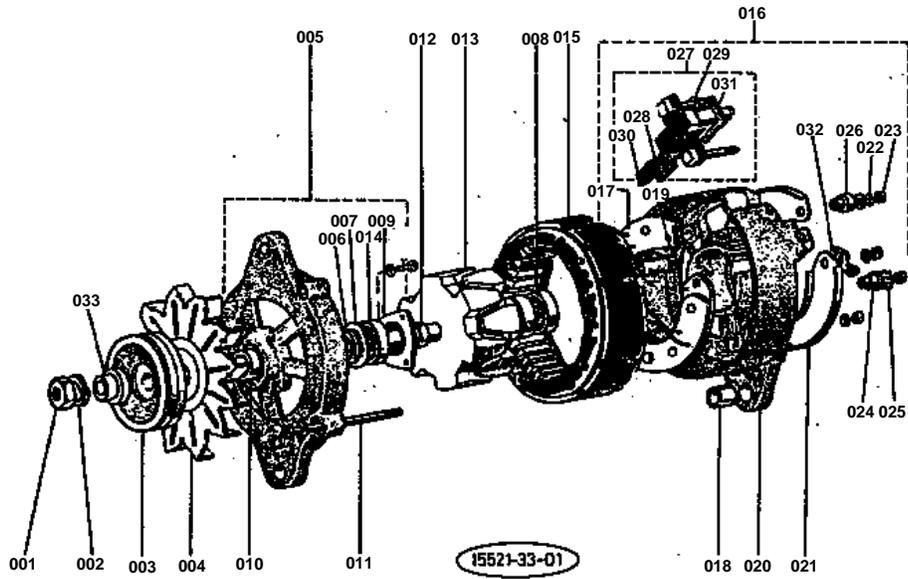



DYNAMO SECTION PARTS

↔ Interchangeable; ≠ not interchangeable; ← new for old; → old for new

REF.No	Part No.	Description	Q'ty	S.No.	I/C	REMARKS	Weight (kgf)	Weight (lb)
001	15221-92010	NUT	1				0.012	0.0264
002	15221-94070	WASHER,SPRING	1				0.008	0.0176
003	15221-64110	PULLEY,DYNAMO	1				0.198	0.4356
004	15221-64130	FAN,DYNAMO	1				0	0
005	15321-64020	FRAME,DRIVE END	1				0	0
006	15221-64790	FELT,OIL	1				0.001	0.0022
007	15221-64830	COVER,FELT	1				0.003	0.0066
008	08121-06201	BEARING,BALL	1				0.036	0.0792
009	15221-64710	PLATE,RETAINER	1				0.018	0.0396
010	15221-64150	COLLAR	1				0.008	0.0176
011	15321-64260	BOLT,THROUGH	2				0.008	0.0176
012	15321-64170	SPACER	1				0.007	0.0154
013	15321-64030	ARMATURE	1				1.29	2.838
014	08141-06202	BEARING,BALL	1				0.043	0.0946
015	15321-64050	YOKE	1				0.75	1.65
016	15321-64070	ASSY FRAME,END	1				0.52	1.144
017	15321-64850	ASSY RECTIFIER	1				0.134	0.2948
018	15221-64210	BUSH	1				0.007	0.0154
019	15321-64880	WASHER,INSULATION	1				0.001	0.0022
020	15321-64060	FRAME,END	1				0.298	0.6556
021	15321-64230	COVER,END	1				0.029	0.0638
022	04512-50050	WASHER,SPRING	5				0	0
023	15221-92030	NUT	5				0.001	0.0022
024	15321-64920	BUSH,INSULATION	1				0.001	0.0022
025	15321-94080	WASHER	1				0	0
026	15221-64910	BUSH,INSULATION	1				0.001	0.0022
027	15321-64310	ASSY HOLDER,BRUSH	1				0.039	0.0858
028	15221-64330	SPRING,BRUSH	2				0.001	0.0022
029	15321-64920	WASHER,INSULATION	2				0.001	0.0022
030	15221-64090	BRUSH	2				0.002	0.0044
031	15321-64940	INSULATOR,TERMINAL	1				0.001	0.0022
032	15321-67570	CLAMP,CORD	1				0.04	0.088
033	15321-64170	SPACER	1				0.007	0.0154

RADIATOR

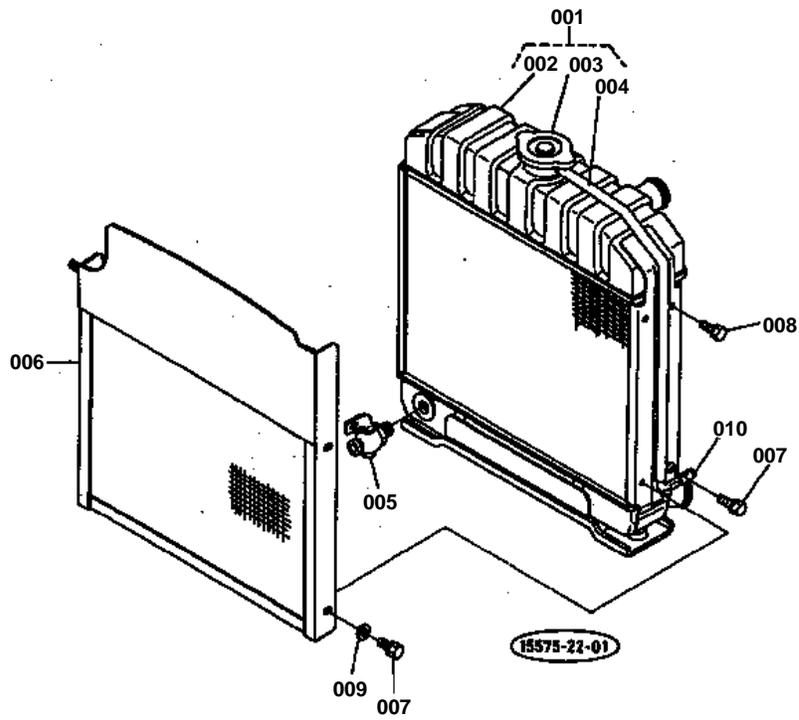



RADIATOR

↔ Interchangeable; ≠ not interchangeable; ← new for old; → old for new

REF.No	Part No.	Description	Q'ty	S.No.	I/C	REMARKS	Weight (kgf)	Weight (lb)
001	15575-72060	ASSY RADIATOR	1				6	13.2
002	99999-99999	BLANK	1			ORDER BY REF.No.001	0	0
003	15101-72030	CAP,RADIATOR	1				0.075	0.165
004	15231-72710	PIPE,WATER OVER FLOW	1				0	0
005	14412-73110	COCK,DRAIN	1				0.09	0.198
006	15321-72250	NET,RADIATOR	1				1.6	3.52
007	01023-50614	BOLT	4				0.005	0.011
008	01023-50612	BOLT	4				0.005	0.011
009	04013-50060	WASHER,PLAIN	3				0	0
010	15021-72040	WHISTLE,STEAM	1				0.03	0.066



WATER PIPE

↔ Interchangeable; ≠ not interchangeable; ← new for old; → old for new

REF.No	Part No.	Description	Q'ty	S.No.	I/C	REMARKS	Weight (kgf)	Weight (lb)
001	15321-72850	PIPE,WATER 1	1				0.181	0.3982
002	15108-72870	BAND	2				0.027	0.0594
003	15521-72910	FLANGE,WATER	1				0	0
004	15521-72920	GASKET,WATER FLANGE	1				0	0
005	01123-50822	BOLT	2				0.012	0.0264
006	01513-50822	STUD	1				0.01	0.022
007	01153-50870	BOLT	1				0.026	0.0572
008	02156-50080	NUT	1				0.004	0.0088
009	04512-50080	WASHER,SPRING	2				0.001	0.0022
010	15521-73340	PIPE,WATER RETURN 2	1				0.025	0.055
011	15321-73340	PIPE,WATER RETURN 1	1				0.016	0.0352
012	15109-73360	BAND,PIPE	2				0.01	0.022
013	15321-72940	PIPE,WATER 4	1				0.134	0.2948
014	15108-72870	BAND	2				0.027	0.0594
015	15321-73260	COVER, THERMOSTAT	1				0.107	0.2354
016	15321-73270	GASKET,THERMOSTAT CO	1				0	0
017	01123-50835	BOLT	2				0.02	0.044
018	15321-73010	ASSY THERMOSTAT	1				0.068	0.1496

WATER PUMP

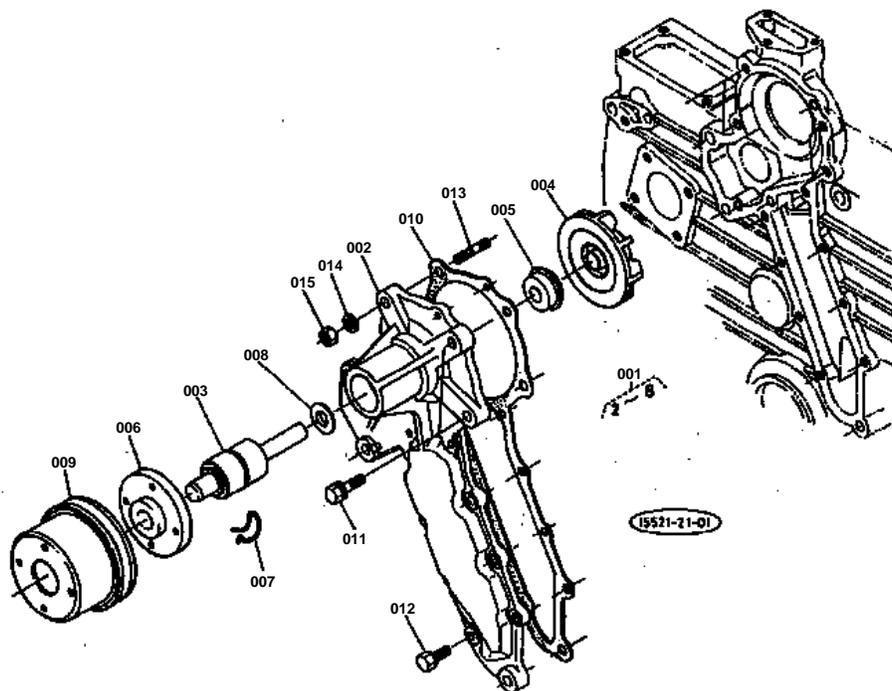



WATER PUMP

↔ Interchangeable; ≠ not interchangeable; ← new for old; → old for new

REF.No	Part No.	Description	Q'ty	S.No.	I/C	REMARKS	Weight (kgf)	Weight (lb)
001	15521-73030	ASSY PUMP,WATER	1				0	0
002	99999-99999	BLANK	1			ORDER BY REF.No.001	0	0
003	15521-73550	BEARING	1				0.235	0.517
004	15321-73510	IMPELLER,WATER PUMP	1				0.22	0.484
005	15121-73050	SET,SEAL	1				0.018	0.0396
006	15521-73520	FLANGE,WATER PUMP SH	1				0.25	0.55
007	15521-94810	PIN,SNAP	1				0.001	0.0022
008	15121-73620	SLINGER	1				0.002	0.0044
009	15521-74250	PULLEY,FAN	1				0.29	0.638
010	15521-73430	GASKET,WATER PUMP	1				0	0
011	01123-50828	BOLT	2				0.014	0.0308
012	01023-50618	BOLT	8				0.006	0.0132
013	01518-50822	STUD	2				0.012	0.0264
014	04512-50080	WATER SPRING	2				0.001	0.0022
015	02156-50080	NUT	2				0.004	0.0088

CLUTCH (SINGLE CLUTCH)

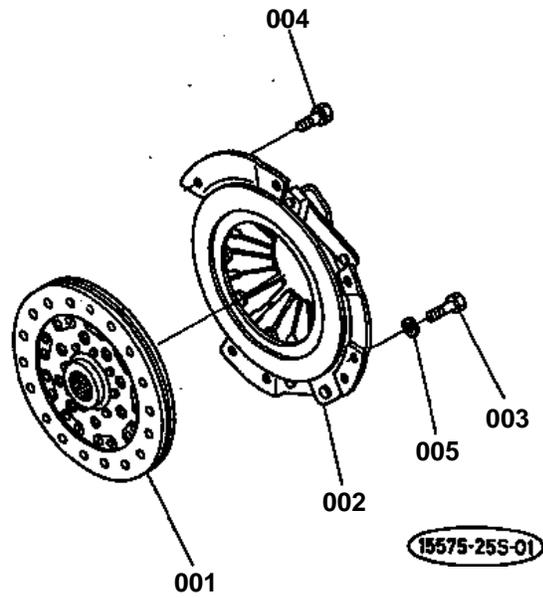



CLUTCH (SINGLE CLUTCH)

↔ Interchangeable; ≠ not interchangeable; ← new for old; → old for new

REF.No	Part No.	Description	Q'ty	S.No.	I/C	REMARKS	Weight (kgf)	Weight (lb)
001	38240-14300	ASSY DISK,CLUTCH	1			(2WD)	0	0
001	35290-14300	ASSY DISK,CLUTCH	1			(4WD)	0	0
002	37300-14500	ASSY PLATE,PRESSURE	1				4.5	9.9
003	34220-14510	BOLT,REAMER	2				0.013	0.0286
004	01123-50816	BOLT	4				0.011	0.0242
005	04512-50080	WASHER,SPRING	2				0.001	0.0022

CLUTCH (DUAL CLUTCH)

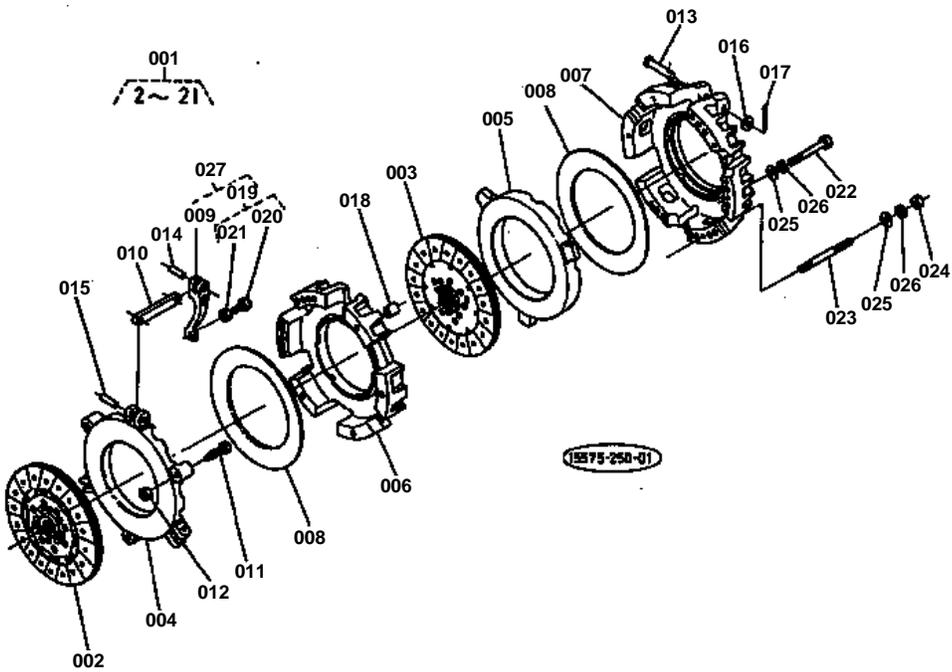



CLUTCH (DUAL CLUTCH)

↔ Interchangeable; ≠ not interchangeable; ← new for old; → old for new

REF.No	Part No.	Description	Q'ty	S.No.	I/C	REMARKS	Weight (kgf)	Weight (lb)
001	35260-14200	ASSY DUAL,CLUTCH	1			(2WD)	0	0
001	35290-14200	ASSY DUAL,CLUTCH	1			(4WD)	0	0
002	38260-14400	ASSY DISK,CLUTCH 1	1			(2WD)	0	0
002	35290-14400	ASSY DISK,CLUTCH 1	1			(4WD)	0	0
003	38260-14450	ASSY DISK,CLUTCH 2	1				0	0
004	35290-14430	ASSY PLATE,PRESSURE	1	>=10001			0	0
004	38260-14430	PLATE,PRESSURE 1	1	>=10001			2.1	4.62
005	38260-14440	PLATE,PRESSURE 2	1	>=10001			0	0
005	35290-14440	PLATE,PRESSURE 2	1	>=10001			2.1	4.62
006	38260-14410	COVER,CLUTCH 1	1				4.7	10.34
007	38260-14420	COVER,CLUTCH 2	1				4.72	10.384
008	38260-14520	SPRING	2				0.318	0.6996
009	99999-99999	BLANK	3			ORDER BY REF.No.027	0	0
010	38260-14530	ASSY ROD,RELEASE	3				0.08	0.176
011	35290-14580	BOLT	3				0.035	0.077
012	38260-14540	NUT	3	>=10001			0.003	0.0066
012	02176-50100	NUT	3	>=10001			0.005	0.011
013	38260-14560	PIN,JOINT	3				0.022	0.0484
014	34370-14570	PIN,STRAIGHT	3				0.016	0.0352
015	34370-14580	PIN,STRAIGHT	3				0.014	0.0308
016	04012-50080	WASHER,PLAIN	3				0.001	0.0022
017	38260-14590	PIN,SPLIT	3				0.001	0.0022
018	38260-14570	KNOCK,PIPE	2				0.007	0.0154
019	35290-99000	KIT,BOLT NUT	1	>=10001			0	0
020	99999-99999	BLANK	0			ORDER BY REF.No.019	0	0
021	99999-99999	BLANK	0			ORDER BY REF.No.019	0	0
022	01153-50800	BOLT	4				0.036	0.0792
023	38260-14620	STUD	2				0	0
024	02156-50080	NUT	2				0.004	0.0088
025	04013-50080	WASHER,PLAIN	2				0	0
026	04512-50080	WASHER,SPRING	6				0.001	0.0022
027	35290-99020	KIT,RELEASE LEVER	1	>=10001			0	0

OIL HYDRAULIC PUMP

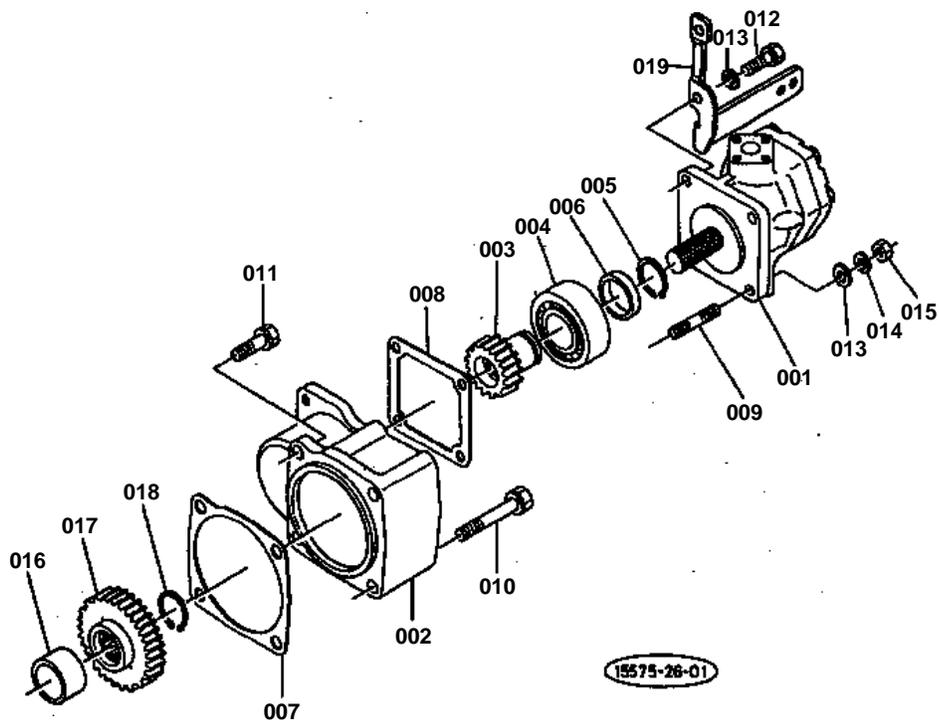



OIL HYDRAULIC PUMP

↔ Interchangeable; ≠ not interchangeable; ← new for old; → old for new

REF.No	Part No.	Description	Q'ty	S.No.	I/C	REMARKS	Weight (kgf)	Weight (lb)
001	38240-76100	PUMP,OIL PRESSURE	1				2	4.4
002	35260-37850	HOLDER,O/P PUMP	1				1.45	3.19
003	35260-37830	GEAR,HELICAL 21	1				0.15	0.33
004	08241-05205	BEARING,BALL	1				0.177	0.3894
005	04612-00350	CIR-CLIP,EXTERNAL	1				0.01	0.022
006	35260-37790	COLLAR	1				0.08	0.176
007	34150-37862	GASKET	1				0	0
008	34150-37870	GASKET	1				0	0
009	01513-50820	STUD	2				0	0
010	01123-50845	BOLT	2				0.02	0.044
011	01123-50822	BOLT	2				0.012	0.0264
012	01123-50828	BOLT	2				0.014	0.0308
013	04012-50080	WASHER,PLAIN	4				0.001	0.0022
014	04512-50080	WASHER,SPRING	2				0.001	0.0022
015	02156-50080	NUT	2				0.004	0.0088
016	34150-37820	COLLAR	1				0.05	0.11
017	35260-37810	GEAR,HELICAL 47	1				0.35	0.77
018	04612-00250	CIR-CLIP,EXTERNAL	1				0.002	0.0044
019	35260-37870	STAY,RH	1				0.13	0.286

OIL HYDRAULIC PUMP SECTION PARTS

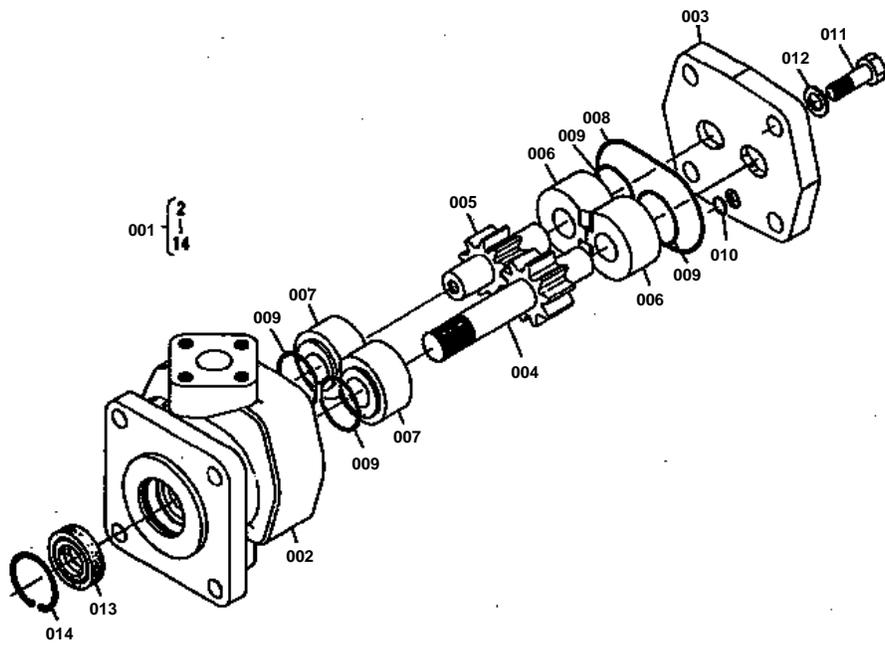



OIL HYDRAULIC PUMP SECTION PARTS

↔ Interchangeable; ≠ not interchangeable; ← new for old; → old for new

REF.No	Part No.	Description	Q'ty	S.No.	I/C	REMARKS	Weight (kgf)	Weight (lb)
001	38240-36100	ASSY GEAR PUMP	1	<=10253		(2WD)	0	0
001	38240-76100	ASSY GEAR PUMP	1	>=10254		(2WD)	2	4.4
001	38240-36100	ASSY GEAR PUMP	1	<=10171		(4WD)	0	0
001	38240-76100	ASSY GEAR PUMP	1	>=10172		(4WD)	2	4.4
002	99999-99999	BLANK	1			ORDER BY REF.No.001	0	0
003	99999-99999	BLANK	1			ORDER BY REF.No.001	0	0
004	99999-99999	BLANK	1			ORDER BY REF.No.001	0	0
005	99999-99999	BLANK	1			ORDER BY REF.No.001	0	0
006	99999-99999	BLANK	2			ORDER BY REF.No.001	0	0
007	99999-99999	BLANK	2			ORDER BY REF.No.001	0	0
008	04810-50550	O RING	1				0.002	0.0044
009	38180-76170	O RING	4				0	0
010	04810-00050	O RING	1				0.001	0.0022
011	01156-51030	BOLT	4				0.02	0.044
012	04011-50100	WASHER,PLAIN	4				0.002	0.0044
013	67211-76190	SEAL,OIL	1				0	0
014	04611-00280	CIR-CLIP,INTERNAL	1				0.002	0.0044

BUMPER

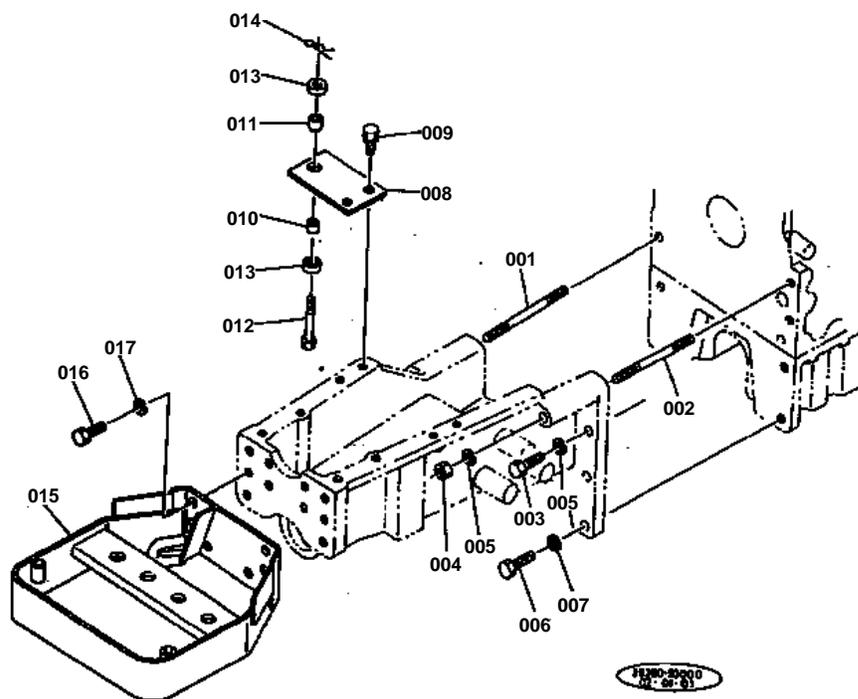

**BUMPER**

↔ Interchangeable; ≠ not interchangeable; ← new for old; → old for new

REF.No	Part No.	Description	Q'ty	S.No.	I/C	REMARKS	Weight (kgf)	Weight (lb)
001	35260-13630	STUD	1				0.08	0.176
002	34260-13640	STUD	1				0.074	0.1628
003	01173-51035	BOLT	1				0.025	0.055
004	37300-14190	NUT	2				0.009	0.0198
005	04512-50100	WASHER,SPRING	3				0	0
006	01173-51235	BOLT	4				0.04	0.088
007	04512-50120	WASHER,SPRING	4				0	0
008	34200-13750	SUPPORT,RADIATOR	2				0.232	0.5104
009	01130-51020	BOLT	4				0	0
010	15111-72180	CUSHION	2				0.015	0.033
011	15111-72190	CUSHION	2				0.016	0.0352
012	15108-72380	BOLT	2				0.04	0.088
013	15111-72200	WASHER	4				0.013	0.0286
014	05515-51000	PIN,SNAP	2				0	0
015	35110-13810	BUMPER	1				5.8	12.76
016	01173-51230	BOLT	4				0.037	0.0814
017	04512-50120	WASHER,SPRING	4				0	0



BATTERY SUPPORT

↔ Interchangeable; ≠ not interchangeable; ← new for old; → old for new

REF.No	Part No.	Description	Q'ty	S.No.	I/C	REMARKS	Weight (kgf)	Weight (lb)
001	35170-13910	SUPPORT,AIR CLEANER	1				0.65	1.43
002	35260-13920	STAY,AIR CLEANER SUP	1				0.07	0.154
003	01150-50812	BOLT	2				0.009	0.0198
004	01120-50816	BOLT	2				0	0
005	04411-50080	WASHER LOCK,TOOTHED	2				0.001	0.0022
006	35260-33210	SUPPORT,BATTERY	1				3.2	7.04
007	01170-51018	BOLT	4				0.017	0.0374
008	04512-50100	WASHER,SPRING	4				0	0
009	32200-33270	RETAINER,BATTERY	1				0.218	0.4796
010	34150-33290	BOLT,HOOK	2				0.055	0.121
011	02014-50060	NUT	4				0.003	0.0066
012	35260-33280	PLATE	1				0.01	0.022
013	01020-50610	BOLT	2				0.005	0.011
014	37220-33330	CORD,BATTERY	1				0	0
015	37150-13920	CUSHION	1				0.005	0.011
016	34150-33350	WASHER	1				0.01	0.022
017	37220-33380	CORD,EARTH	2				0.21	0.462
018	02114-50080	NUT	1				0.005	0.011

SAFETY COVER

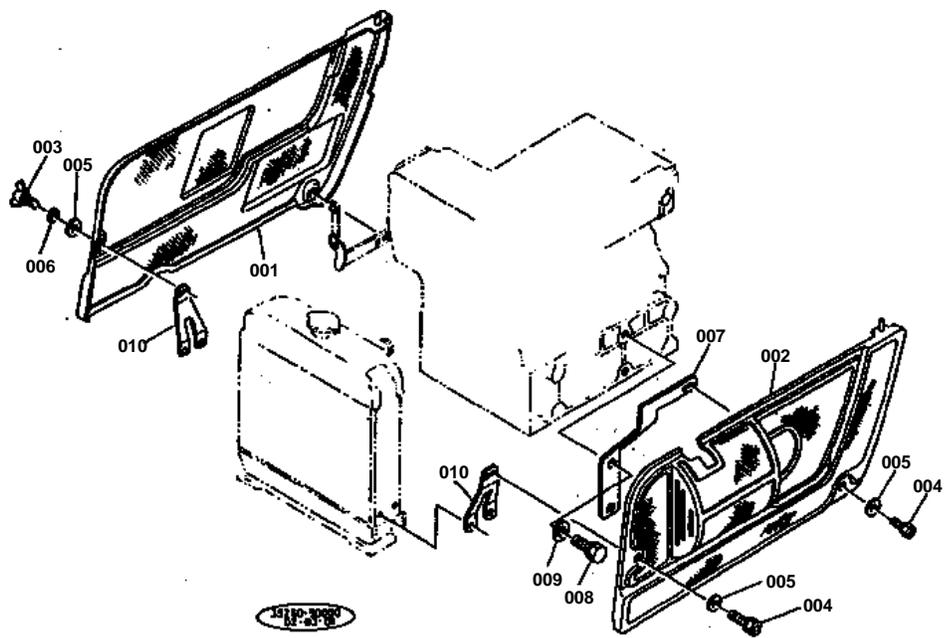



SAFETY COVER

↔ Interchangeable; ≠ not interchangeable; ← new for old; → old for new

REF.No	Part No.	Description	Q'ty	S.No.	I/C	REMARKS	Weight (kgf)	Weight (lb)
001	37220-13850	COVER,SAFETY RH	1				1.27	2.794
002	35260-13860	COVER,SAFETY LH	1				1.68	3.696
003	01811-50615	BOLT,WING	2				0.015	0.033
004	01202-50616	BOLT	2				0.006	0.0132
005	04015-50060	WASHER,PLAIN	4				0	0
006	04512-50060	WASHER,SPRING	2				0	0
007	35260-13870	STAY LH	1				0.285	0.627
008	01133-51225	BOLT	2				0.038	0.0836
009	04013-50120	WASHER,PLAIN	2				0	0
010	35260-13880	STAY FRONT	2				0.1	0.22

MID CASE

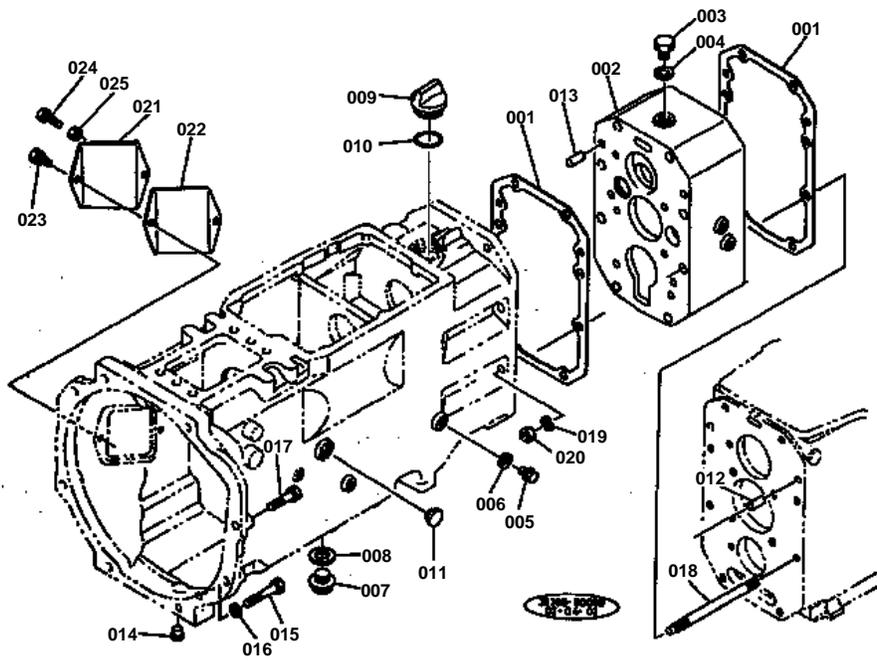

**MID CASE**

↔ Interchangeable; ≠ not interchangeable; ← new for old; → old for new

REF.No	Part No.	Description	Q'ty	S.No.	I/C	REMARKS	Weight (kgf)	Weight (lb)
001	35340-14140	GASKET	2				0.01	0.022
002	35260-21153	CASE,MID	1				12.25	26.95
003	06311-45030	PLUG	1				0.06	0.132
004	04717-01700	WASHER,SEAL	1				0.003	0.0066
005	06311-25010	PLUG	1				0.014	0.0308
006	04717-01000	WASHER,SEAL	1				0.001	0.0022
007	34150-14260	PLUG,DRAIN	1				0	0
008	04717-02150	WASHER,SEAL	1				0.004	0.0088
009	38430-21410	PLUG	1				0.045	0.099
010	04811-50300	O RING	1				0.001	0.0022
011	38240-14210	GAUGE,OIL	1				0.01	0.022
012	05012-01018	PIN,STRAIGHT	2				0.012	0.0264
013	05012-01022	PIN,STRAIGHT	2				0.014	0.0308
014	32210-27580	PLUG,BLIND	6				0.001	0.0022
015	01173-51065	BOLT	7				0.04	0.088
016	04512-50100	WASHER,SPRING	7				0	0
017	01133-51040	BOLT	1				0.03	0.066
018	35260-14180	STUD	3				0.14	0.308
019	04512-50120	WASHER,SPRING	8				0	0
020	35340-27360	NUT	8				0.015	0.033
021	34150-14160	COVER,HOUSING	1				0.15	0.33
022	34150-14170	GASKET,HOUSING	1				0.03	0.066
023	01120-50816	BOLT	1				0	0
024	01150-50825	BOLT	1				0	0
025	02114-50080	NUT	1				0.005	0.011

CLUTCH ROD

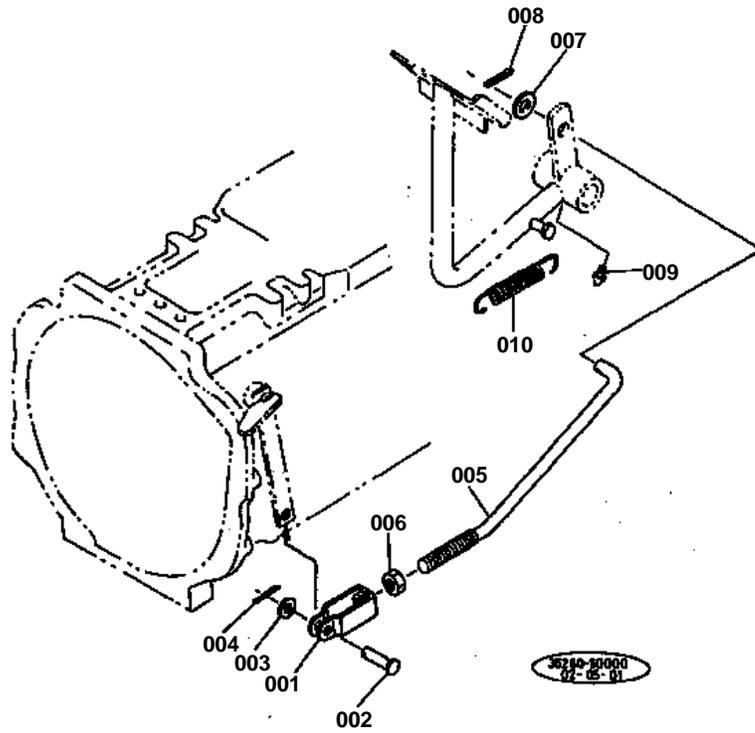



CLUTCH ROD

↔ Interchangeable; ≠ not interchangeable; ← new for old; → old for new

REF.No	Part No.	Description	Q'ty	S.No.	I/C	REMARKS	Weight (kgf)	Weight (lb)
001	34150-15630	JOINT,FORKED	1				0.095	0.209
002	05112-50822	PIN,JOINT	1				0.01	0.022
003	04012-50080	WASHER,PLAIN	1				0.001	0.0022
004	05511-50220	PIN,SPLIT	1				0.001	0.0022
005	35260-15640	ROD,CLUTCH	1				0.205	0.451
006	02172-50120	NUT	1				0.01	0.022
007	04013-50120	WASHER,PLAIN	1				0	0
008	05511-50425	PIN,SPLIT	1				0.003	0.0066
009	06613-10675	NIPPLE,GREASE	1				0.003	0.0066
010	37150-15840	SPRING	1				0.06	0.132

STEERING WHEEL

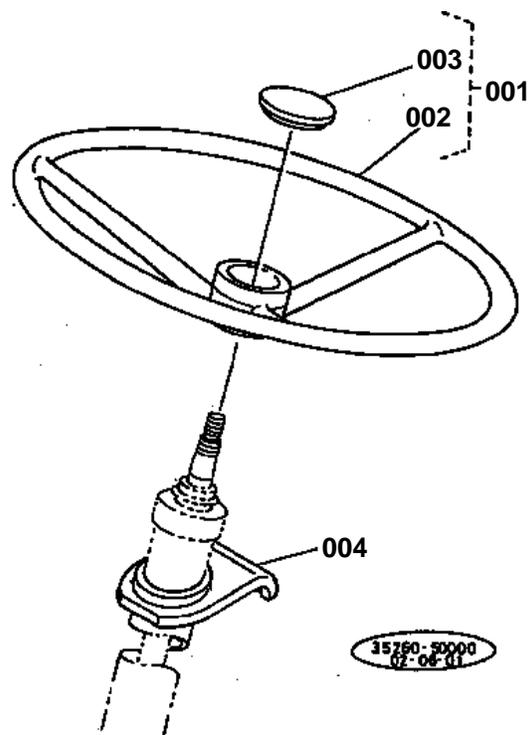



STEERING WHEEL

↔ Interchangeable; ≠ not interchangeable; ← new for old; → old for new

REF.No	Part No.	Description	Q'ty	S.No.	I/C	REMARKS	Weight (kgf)	Weight (lb)
001	66611-41400	ASSY WHEEL,STEERING	1				0	0
002	99999-99999	BLANK	1			ORDER BY REF.No.001	0	0
003	66611-41420	CAP,STEERING WHEEL	1				0.026	0.0572
004	37150-16850	HOLDER,POST	1				0.04	0.088

HAND ACCELERATOR

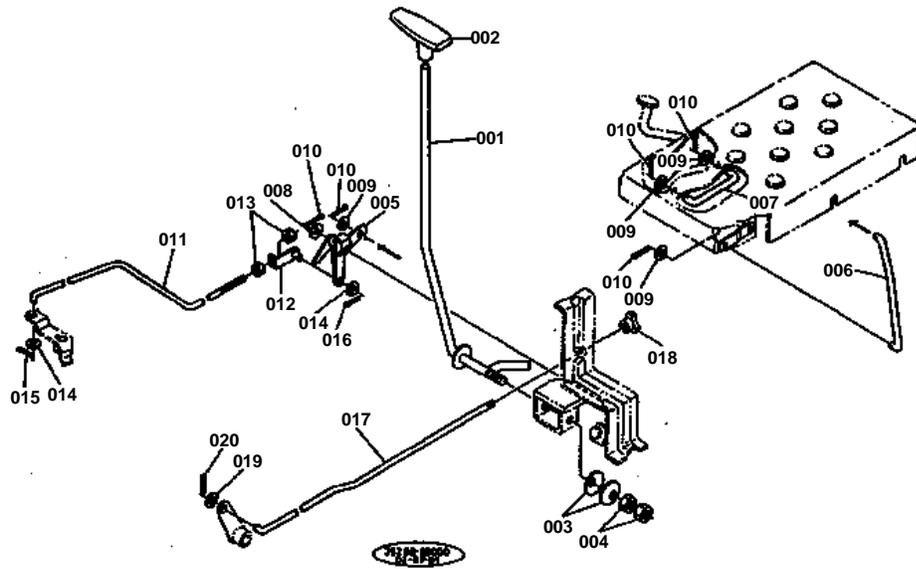



HAND ACCELERATOR

↔ Interchangeable; ≠ not interchangeable; ← new for old; → old for new

REF.No	Part No.	Description	Q'ty	S.No.	I/C	REMARKS	Weight (kgf)	Weight (lb)
001	35170-17120	LEVER,HAND ACCEL	1				0.345	0.759
002	35320-17170	GRIP,ACCEL	1				0.018	0.0396
003	34260-17190	SPRING	2				0.002	0.0044
004	02118-50100	NUT	2				0.005	0.011
005	35260-17320	LINK,ACCEL	1				0.1	0.22
006	37150-17570	ROD,ACCEL 1	1				0.06	0.132
007	37150-17580	ROD,ACCEL 2	1				0.025	0.055
008	04012-50080	WASHER,PLAIN	1				0.001	0.0022
009	04012-50060	WASHER,PLAIN	4				0.001	0.0022
010	05511-50212	PIN,SPLIT	5				0.001	0.0022
011	35260-17360	ROD,ACCEL	1				0.13	0.286
012	34150-17390	JOINT,ROD	1				0.025	0.055
013	02012-50060	NUT	2				0	0
014	04012-50060	WASHER,PLAIN	2				0.001	0.0022
015	05511-50212	PIN,SPLIT	1				0.001	0.0022
016	05511-51612	PIN,SPLIT	1				0.001	0.0022
017	35260-17150	ROD,STOP	1				0.14	0.308
018	35260-17160	KNOB	1				0.015	0.033
019	04012-50060	WASHER,PLAIN	1				0.001	0.0022
020	05511-50212	PIN,SPLIT	1				0.001	0.0022

HOOD

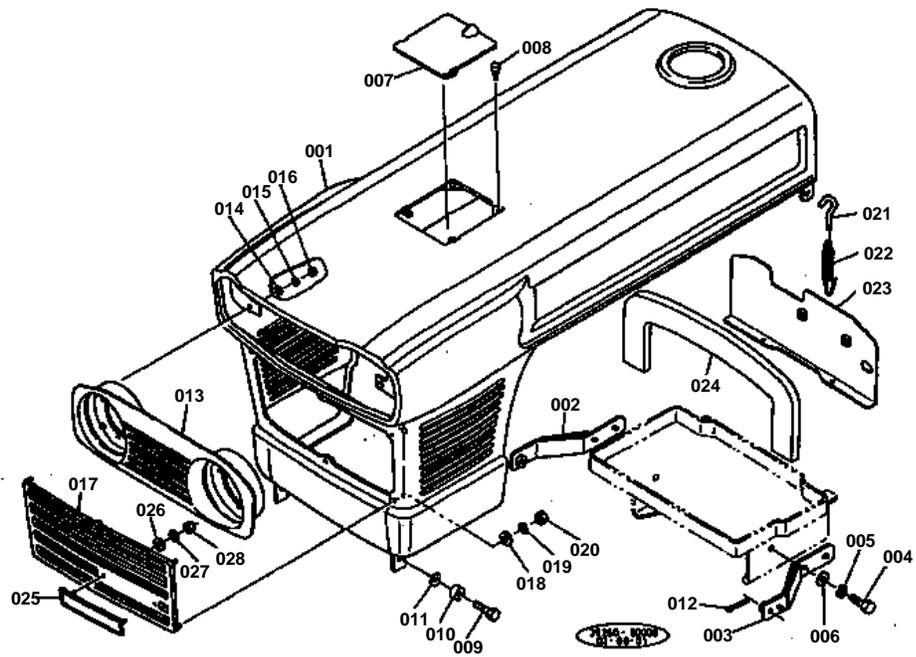

**HOOD**

↔ Interchangeable; ≠ not interchangeable; ← new for old; → old for new

REF.No	Part No.	Description	Q'ty	S.No.	I/C	REMARKS	Weight (kgf)	Weight (lb)
001	35260-18110	ASSY BONNET	1				12	26.4
002	37220-18120	SUPPORT,BONNET RH	1				0.33	0.726
003	37220-18130	SUPPORT,BONNET LH	1				0.31	0.682
004	01173-51025	BOLT	4				0.021	0.0462
005	04512-50100	WASHER,SPRING	4				0	0
006	04015-50100	WASHER,PLAIN	4				0.016	0.0352
007	32280-18120	COVER,BONNET	1				0.226	0.4972
008	32280-18180	CUSHION	2				0.001	0.0022
009	34150-18170	BOLT	2				0.04	0.088
010	34150-18180	CUSHION	2				0.003	0.0066
011	04013-50120	WASHER,PLAIN	2				0	0
012	05511-50425	PIN,SPLIT	2				0.003	0.0066
013	35260-18150	GRILLE,LAMP	1				0.815	1.793
014	04015-50050	WASHER,PLAIN	4				0.004	0.0088
015	04512-50050	WASHER,SPRING	4				0	0
016	02054-50050	NUT	4				0.002	0.0044
017	35260-18190	GRILLE,BONNET	1				0.395	0.869
018	04013-50050	WASHER,PLAIN	6				0	0
019	04512-50050	WASHER,SPRING	6				0	0
020	02054-50050	NUT	6				0.002	0.0044
021	37150-18143	HOOK,BONNET	2				0.021	0.0462
022	37150-18170	SPRING	2				0.025	0.055
023	35260-18060	PLATE,SHUTTER	1				0.565	1.243
024	34200-18070	CUSHION	1				0.012	0.0264
025	32240-18260	MARK,FRONT KUBOTA	1				0.027	0.0594
026	04013-50050	WASHER,PLAIN	2				0	0
027	04512-50050	WASHER,SPRING	2				0	0
028	02054-50050	NUT	2				0.002	0.0044



MAIN SHIFT LEVER

↔ Interchangeable; ≠ not interchangeable; ← new for old; → old for new

REF.No	Part No.	Description	Q'ty	S.No.	I/C	REMARKS	Weight (kgf)	Weight (lb)
001	38430-21210	COVER,S-CHANGE	1				1.1	2.42
002	34650-59140	GASKET	1				0	0
003	34150-21250	PLUG	7				0.002	0.0044
004	01123-50840	BOLT	4				0.018	0.0396
005	01153-50840	BOLT	1				0.018	0.0396
006	07715-00803	BALL	2				0.004	0.0088
007	04717-00800	WASHER,SEAL	1				0.001	0.0022
008	35260-23710	BASE,SPEED CHANGE	1				0.39	0.858
009	38430-23720	RING,SQUARE	1				0.005	0.011
010	34150-23740	PIN,SET	4				0.002	0.0044
011	01120-50822	BOLT	5				0	0
012	01153-50865	BOLT	1				0.025	0.055
013	04512-50080	WASHER,SPRING	1				0.001	0.0022
014	35260-23810	LEVER,MAIN S-CHANGE	1				0.355	0.781
015	35260-23820	LEVER,SHUTTLE	1				0.4	0.88
016	32150-23860	GRIP,LEVER	1				0.037	0.0814
017	38240-24920	GRIP,LEVER	1				0.04	0.088
018	34150-23940	SHIELD,LEVER	2				0.025	0.055
019	04811-00120	O RING	2				0.001	0.0022
020	32240-23950	WASHER	4				0.002	0.0044
021	32240-23920	SPRING	2				0.007	0.0154
022	31220-23930	CIR-CLIP,EXTERNAL	2				0.001	0.0022
023	34150-23870	SHIELD	2				0	0

GEAR DRIVE SYSTEM

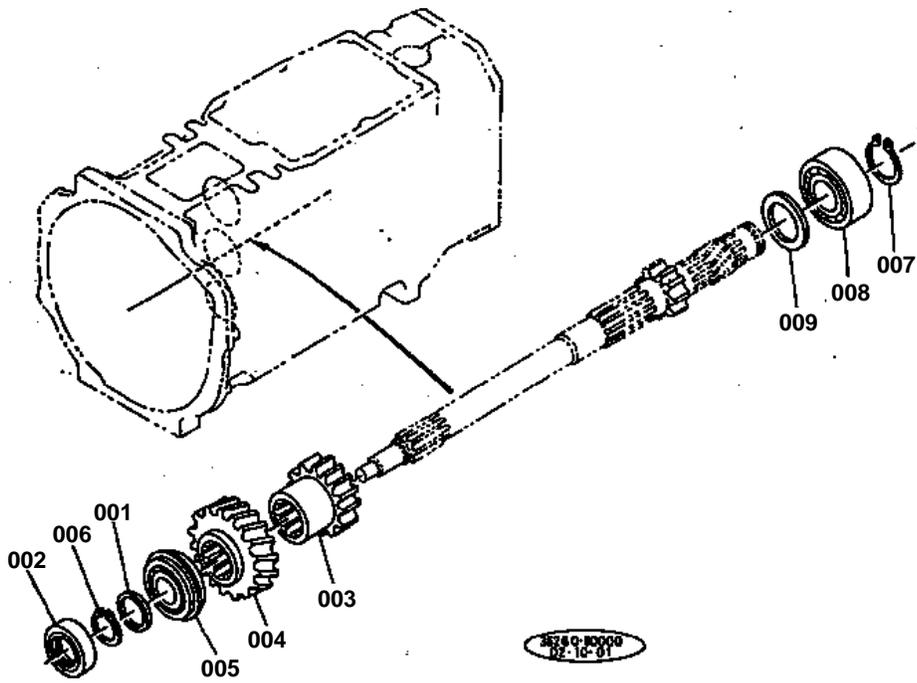



GEAR DRIVE SYSTEM

↔ Interchangeable; ≠ not interchangeable; ← new for old; → old for new

REF.No	Part No.	Description	Q'ty	S.No.	I/C	REMARKS	Weight (kgf)	Weight (lb)
001	34150-21560	WASHER	1				0.01	0.022
002	09502-55210	SEAL,OIL	1				0.025	0.055
003	35260-21520	GEAR,22	1				0.33	0.726
004	35340-21532	GEAR,24	1				0.405	0.891
005	08151-06305	BEARING,BALL	1				0.233	0.5126
006	37150-21550	CIR-CLIP,EXTERNAL	1				0.06	0.132
007	04612-00300	CIR-CLIP,EXTERNAL	1				0.003	0.0066
008	08241-03206	BEARING,BALL	1				0.302	0.6644
009	38240-21560	COLLAR	1				0.01	0.022

COUNTER SHAFT

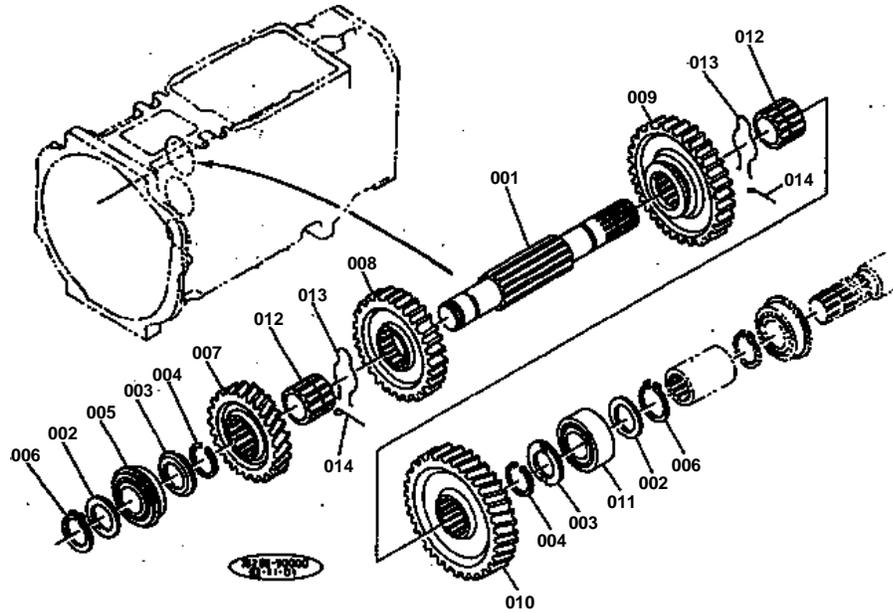



COUNTER SHAFT

↔ Interchangeable; ≠ not interchangeable; ← new for old; → old for new

REF.No	Part No.	Description	Q'ty	S.No.	I/C	REMARKS	Weight (kgf)	Weight (lb)
001	35300-21610	SHAFT,COUNTER	1				1.115	2.453
002	34150-21560	WASHER	2				0.01	0.022
003	37150-21760	COLLAR,THRUST	2				0.017	0.0374
004	37150-21790	RING	2				0.001	0.0022
005	08151-06205	BEARING,BALL	1				0.131	0.2882
006	37150-21550	CIR-CLIP,EXTERNAL	2				0.06	0.132
007	35340-21710	GEAR,31	1				0.47	1.034
008	35260-21720	GEAR,38	1				0.67	1.474
009	35260-21730	GEAR,44	1				0.895	1.969
010	37150-21740	GEAR,45	1				1.08	2.376
011	08241-03205	BEARING,BALL	1				0	0
012	37150-21750	BOSS,SPLINE	2				0.088	0.1936
013	35340-21782	RING	2				0.007	0.0154
014	35340-21792	WIRE	2				0.001	0.0022

CONDUCT SHAFT

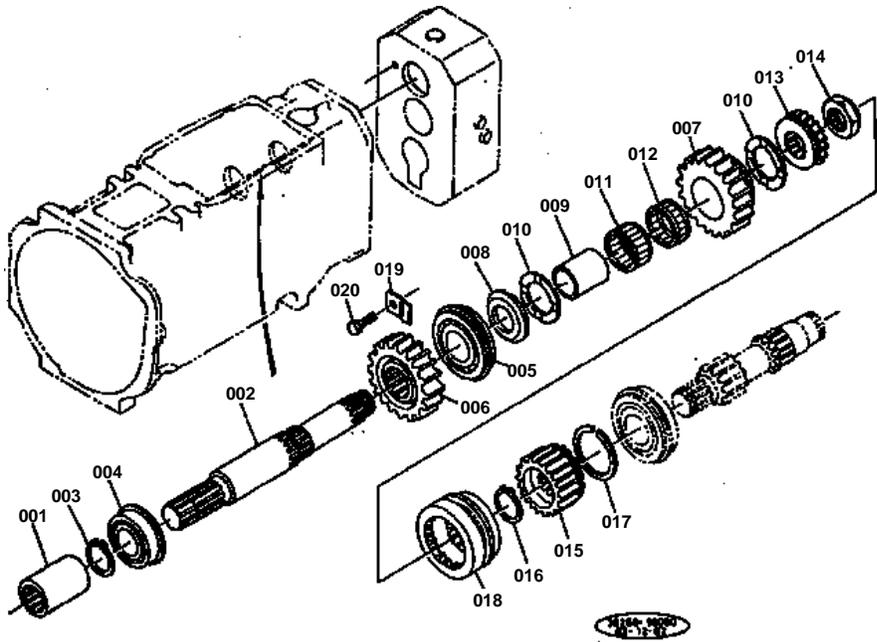



CONDUCT SHAFT

↔ Interchangeable; ≠ not interchangeable; ← new for old; → old for new

REF.No	Part No.	Description	Q'ty	S.No.	I/C	REMARKS	Weight (kgf)	Weight (lb)
001	35300-21660	COUPLING	1				0.19	0.418
002	35260-21810	SHAFT,CREEP CHANGE	1				1.14	2.508
003	37150-21550	CIR-CLIP,EXTERNAL	1				0.06	0.132
004	08151-06205	BEARING,BALL	1				0.131	0.2882
005	35260-23110	BEARING,BALL	1				0.235	0.517
006	35260-23120	GEAR,24	1				0.48	1.056
007	35260-23220	GEAR,23	1				0.515	1.133
008	38430-21762	COLLAR,THRUST	1				0.035	0.077
009	35260-23230	RING,INNER	1				0.095	0.209
010	35260-23240	WASHER	2				0.01	0.022
011	38240-21850	BEARING,NEEDLE	1				0.05	0.11
012	08823-22810	BEARING,NEEDLE	1				0	0
013	35260-23260	BOSS,SPLINE 1	1				0.17	0.374
014	35260-23250	NUT,22	1				0	0
015	35260-23270	BOSS,SPLINE 2	1				0.3	0.66
016	37150-21550	CIR-CLIP,EXTERNAL	1				0.06	0.132
017	35260-23280	RING	1				0	0
018	35260-23290	SHIFTER	1				0	0
019	35260-23300	RETAINER,BEARING	1	>=10605		(2WD)	0.02	0.044
019	35260-23300	RETAINER,BEARING	1	>=10552		(4WD)	0.02	0.044
020	01123-50816	BOLT	1	>=10605		(2WD)	0.011	0.0242
020	01123-50816	BOLT	1	>=10552		(4WD)	0.011	0.0242

REVERSE SHAFT

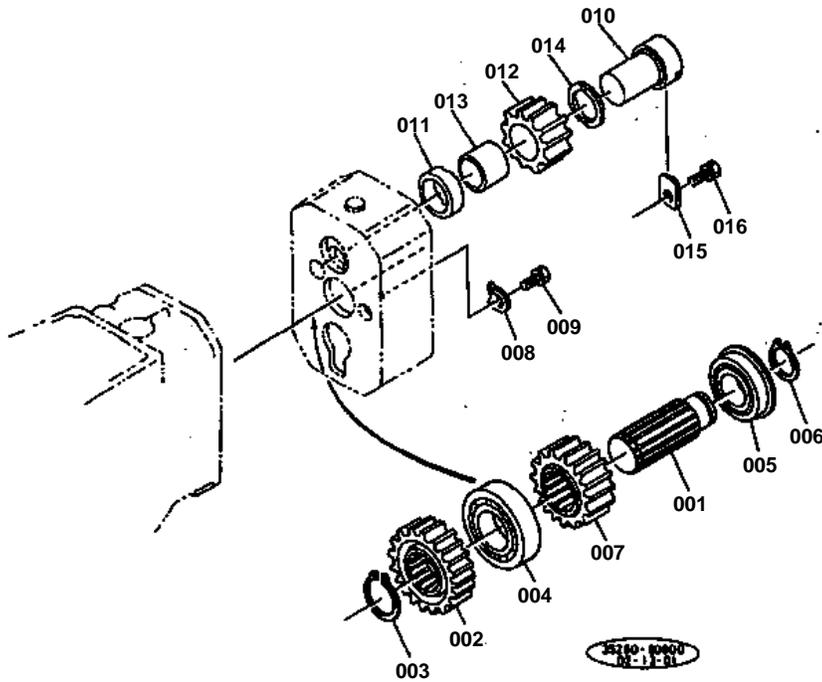

REF. No. ① 3520-2313-4

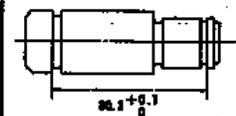

REF. No. ① 3520-2314-2

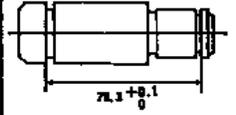

REF. No. ② 3520-2314-0

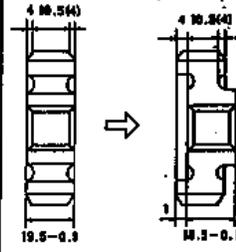

REF. No. ③ 3520-2314-0



REVERSE SHAFT

↔ Interchangeable; ≠ not interchangeable; ← new for old; → old for new

REF.No	Part No.	Description	Q'ty	S.No.	I/C	REMARKS	Weight (kgf)	Weight (lb)
001	35260-23130	SHAFT,REVERSE 1	1	≤10604		(2WD)	0.41	0.902
001	35260-23132	SHAFT,REVERSE 1	1	≥10605		(2WD)	0.4	0.88
001	35260-23130	SHAFT,REVERSE 1	1	≤10551		(4WD)	0.41	0.902
001	35260-23132	SHAFT,REVERSE 1	1	≥10552		(4WD)	0.4	0.88
002	35260-23140	GEAR,22	1	≤10604		(2WD)	0.36	0.792
002	35260-23142	GEAR,22	1	≥10605		(2WD)	0.35	0.77
002	35260-23140	GEAR,22	1	≤10551		(4WD)	0.36	0.792
002	25260-23142	GEAR,22	1	≥10552		(4WD)	0	0
003	04612-00300	CIR-CLIP,EXTERNAL	1				0.003	0.0066
004	38450-25370	BEARING,BALL	1				0.2	0.44
005	08151-06205	BEARING,BALL	1				0.131	0.2882
006	37150-21550	CIR-CLIP,EXTERNAL	1				0.06	0.132
007	35260-23150	GEAR,19	1				0.405	0.891
008	34150-21942	RETAINER,BEARING	1				0.035	0.077
009	01120-50816	BOLT	1				0	0
010	35260-23160	SHAFT,REVERSE 2	1				0.275	0.605
011	35260-23170	COLLAR	1				0.055	0.121
012	35260-23180	GEAR,15	1				0.2	0.44
013	35260-23190	BUSH	1				0.025	0.055
014	35260-23200	COLLAR	1				0.005	0.011
015	35260-23211	STOPPER	1				0	0
016	01120-50816	BOLT	1				0	0

SPIRAL BEVEL PINION

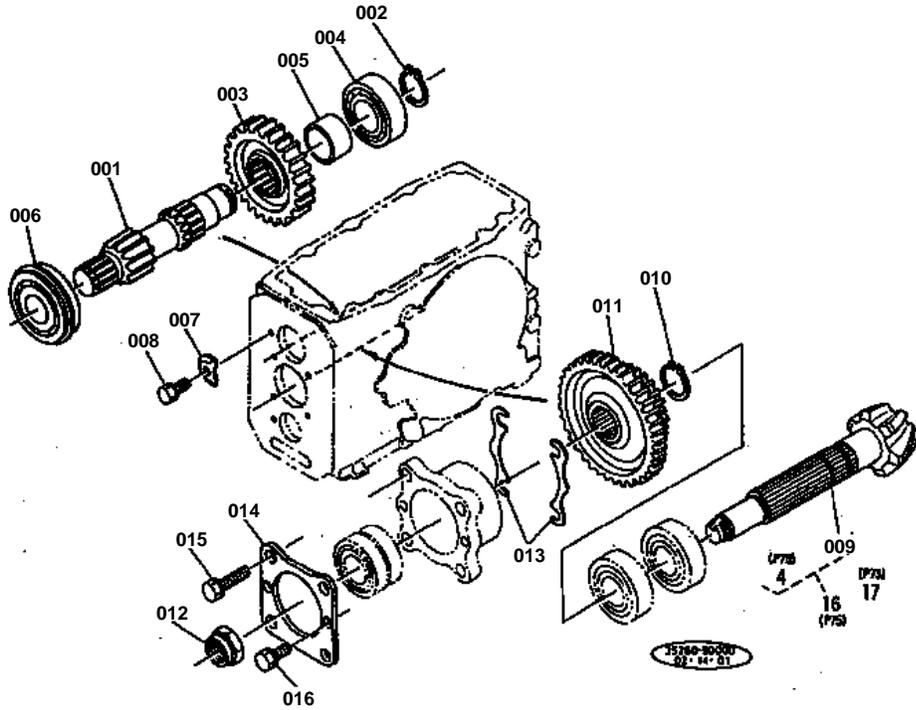



SPIRAL BEVEL PINION

↔ Interchangeable; ≠ not interchangeable; ← new for old; → old for new

REF.No	Part No.	Description	Q'ty	S.No.	I/C	REMARKS	Weight (kgf)	Weight (lb)
001	35260-21910	SHAFT,13GEAR	1				0.76	1.672
002	37150-21550	CIR-CLIP, EXTERNAL	1				0.06	0.132
003	35260-21920	GEAR,27	1				0.46	1.012
004	08101-06305	BEARING,BALL	1				0.23	0.506
005	37150-21940	COLLAR	1				0.05	0.11
006	08151-06305	BEARING,BALL	1				0.233	0.5126
007	34150-21942	RETAINER, BEARING	1				0.035	0.077
008	01123-50820	BOLT	1				0.011	0.0242
009	99999-99999	BLANK	1			ORDER BY REF.No.017 ON FIG.No.063	0	0
010	04612-00300	CIR-CLIP, EXTERNAL	1				0.003	0.0066
011	35260-21950	GEAR,23-46	1				1.13	2.486
012	31220-22340	NUT,22	1				0.033	0.0726
013	34150-22610	SHIM 0.5	2				0.01	0.022
013	34150-22620	SHIM 0.2	4				0.005	0.011
013	34150-22630	SHIM 0.1	2				0.005	0.011
014	34150-22170	COVER,BEARING	1				0.16	0.352
015	01133-51035	BOLT	4				0.03	0.066
016	01123-50816	BOLT	2				0.011	0.0242

POWER TAKE-OFF SHAFT

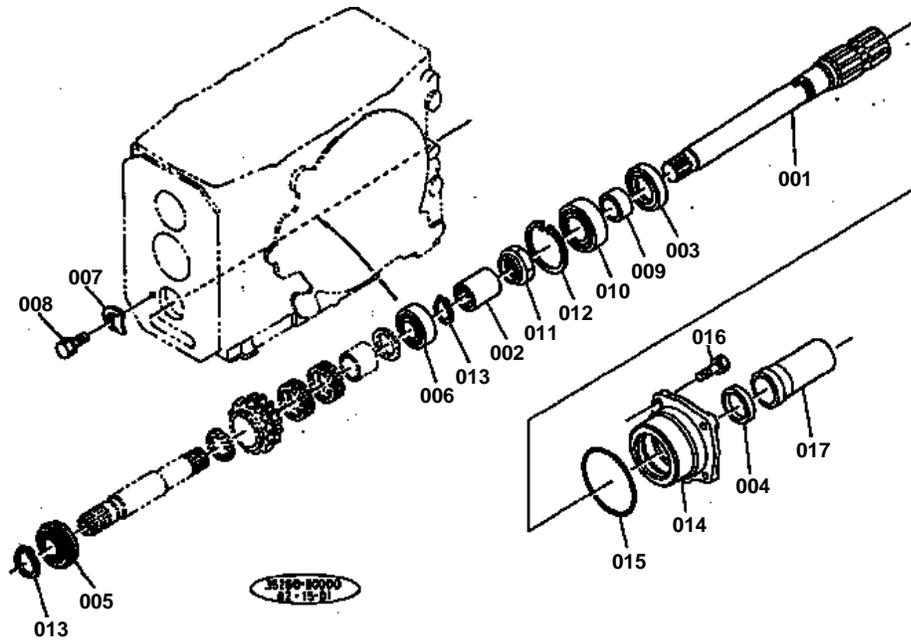



POWER TAKE-OFF SHAFT

↔ Interchangeable; ≠ not interchangeable; ← new for old; → old for new

REF.No	Part No.	Description	Q'ty	S.No.	I/C	REMARKS	Weight (kgf)	Weight (lb)
001	38240-25310	SHAFT,PTO	1				0	0
002	37150-21680	COUPLING	1				0	0
003	37150-25360	SEAL,OIL	1				0.025	0.055
004	37150-25370	SLINGER	1				0.007	0.0154
005	08151-06205	BEARING,BALL	1				0.131	0.2882
006	08101-06205	BEARING,BALL	1				0.14	0.308
007	34150-21942	RETAINER,BEARING	1				0.035	0.077
008	01123-50820	BOLT	1				0.011	0.0242
009	37300-25350	COLLAR,OIL SEAL	1				0.032	0.0704
010	08101-06206	BEARING,BALL	1				0.196	0.4312
011	34150-25320	NUT	1				0.03	0.066
012	04611-00620	CIR-CLIP,INTERNAL	1				0.011	0.0242
013	37150-21550	CIR-CLIP,EXTERNAL	2				0.06	0.132
014	37150-25410	CASE,BEARING	1				1.02	2.244
015	04811-50800	O RING	1				0.003	0.0066
016	01123-50825	BOLT	4				0.013	0.0286
017	31220-25820	CAP	1				0.055	0.121

SPEED CHANGE SYSTEM 1

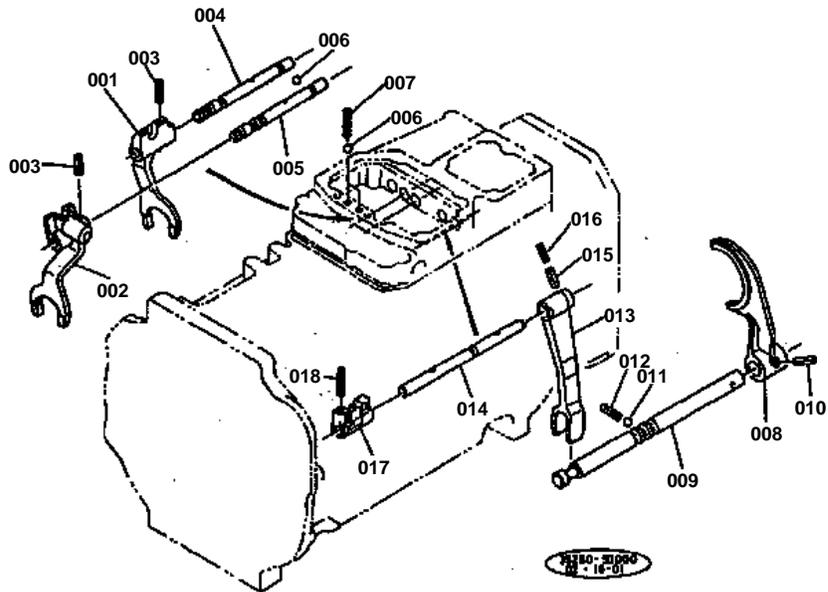



SPEED CHANGE SYSTEM 1

↔ Interchangeable; ≠ not interchangeable; ← new for old; → old for new

REF.No	Part No.	Description	Q'ty	S.No.	I/C	REMARKS	Weight (kgf)	Weight (lb)
001	35260-23510	FORK,SHIFT	1				0.21	0.462
002	35305-23520	FORK,SHIFT	1				0.28	0.616
003	05411-00420	PIN,SPRING	2				0.001	0.0022
004	37150-23540	ROD,FORK	1				0.12	0.264
005	37150-23550	ROD,FORK	1				0.12	0.264
006	07715-01605	BALL	3				0.003	0.0066
007	62231-18530	SPRING,STOPPER	2				0.01	0.022
008	35260-23530	FORK,SHIFT	1				0	0
009	35260-23570	ROD,FORK	1				0.35	0.77
010	05411-00528	PIN,SPRING	1				0.003	0.0066
011	07715-01605	BALL	1				0.003	0.0066
012	62231-18530	SPRING,STOPPER	1				0.01	0.022
013	35260-23310	LEVER,REVERSE	1				0.315	0.693
014	38430-24770	ROD,FORK	1				0.185	0.407
015	05411-00420	PIN,SPRING	1				0.001	0.0022
016	05411-02520	PIN,SPRING	1				0.001	0.0022
017	35260-23320	HOLDER,FORK ROD	1				0.165	0.363
018	05411-00436	PIN,SPRING	1				0.002	0.0044

SPEED CHANGE SYSTEM 2

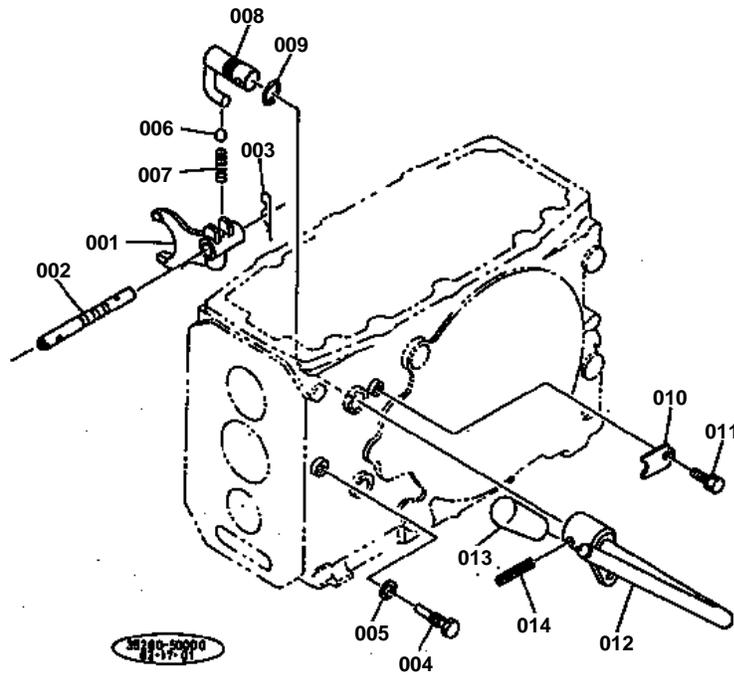



SPEED CHANGE SYSTEM 2

↔ Interchangeable; ≠ not interchangeable; ← new for old; → old for new

REF.No	Part No.	Description	Q'ty	S.No.	I/C	REMARKS	Weight (kgf)	Weight (lb)
001	37150-24110	FORK,SHIFT	1				0.182	0.4004
002	38240-24130	SHAFT,FORK	1				0.115	0.253
003	05515-51200	PIN,SNAP	1				0	0
004	37150-23120	SCREW,SET	1				0.02	0.044
005	04717-00800	WASHER,SEAL	1				0.001	0.0022
006	07715-01605	BALL	1				0.003	0.0066
007	35260-24110	SPRING	1				0.02	0.044
008	37150-24310	LEVER,SHIFT	1				0.145	0.319
009	04811-00150	O RING	1				0.001	0.0022
010	34150-24350	STOPPER,LEVER	1				0.015	0.033
011	01120-50816	BOLT	1				0	0
012	35260-24430	LEVER,AUX S-CHANGE	1				0.445	0.979
013	06914-00120	GRIP,LEVER	1				0.018	0.0396
014	05411-00632	PIN,SPRING	1				0.004	0.0088

PTO SHIFT LEVER

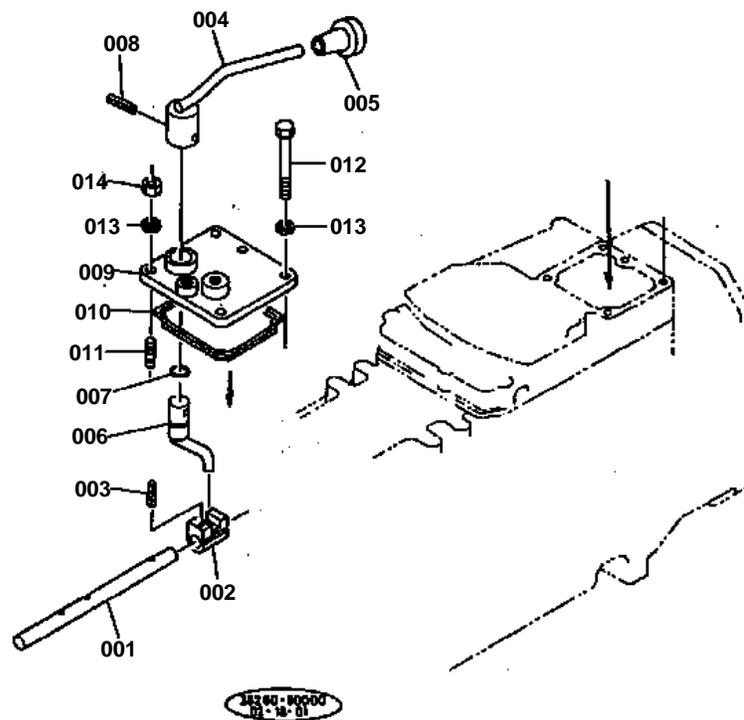



PTO SHIFT LEVER

↔ Interchangeable; ≠ not interchangeable; ← new for old; → old for new

REF.No	Part No.	Description	Q'ty	S.No.	I/C	REMARKS	Weight (kgf)	Weight (lb)
001	35260-24760	ROD,FORK	1				0.15	0.33
002	35260-24770	HOLDER,FORK ROD	1				0.05	0.11
003	05411-00420	PIN,SPRING	1				0.001	0.0022
004	35260-24853	LEVER,PTO	1				0.2	0.44
005	38240-24410	GRIP	1				0.025	0.055
006	35260-24860	LEVER,PTO S-CHANGE	1				0.105	0.231
007	04811-00150	O RING	1				0.001	0.0022
008	05411-00632	PIN,SPRING	1				0.004	0.0088
009	35260-24830	COVER	1				0.47	1.034
010	38430-24840	RING,SQUARE	1				0.005	0.011
011	01512-50818	STUD	3				0	0
012	01153-50865	BOLT	2				0.025	0.055
013	04512-50080	WASHER,SPRING	5				0.001	0.0022
014	02114-50080	NUT	3				0.005	0.011

DIFFERENTIAL LOCK PEDAL

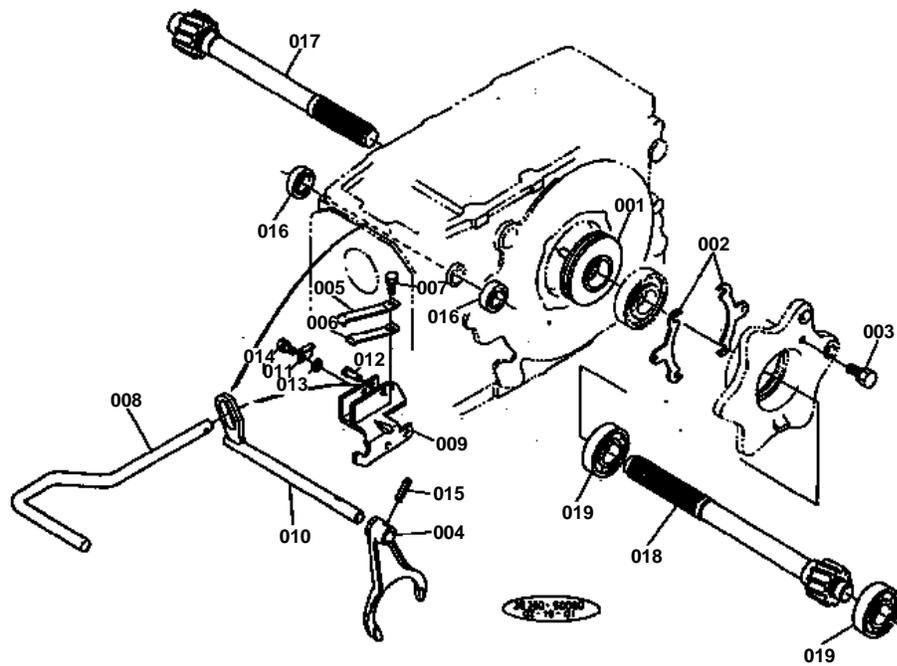



DIFFERENTIAL LOCK PEDAL

↔ Interchangeable; ≠ not interchangeable; ← new for old; → old for new

REF.No	Part No.	Description	Q'ty	S.No.	I/C	REMARKS	Weight (kgf)	Weight (lb)
001	34150-26615	SHIFTER,DIFF LOCK	1				0.4	0.88
002	37150-26160	SHIM 0.2	12				0.005	0.011
002	37150-26170	SHIM 0.1	8				0.005	0.011
002	37150-26180	SHIM 0.5	4				0.01	0.022
003	01133-51030	BOLT	8				0.025	0.055
004	37150-26630	FORK,SHIFT	1				0.375	0.825
005	37150-26643	SPRING	1				0.033	0.0726
006	37150-26660	SPRING	1				0.025	0.055
007	01120-50816	BOLT	1				0	0
008	37300-26650	PEDAL,DIFF LOCK	1				0.635	1.397
009	35210-26670	BRACKET,PEDAL	1				0.59	1.298
010	37300-26680	CAM,DIFF LOCK	1				0.252	0.5544
011	35110-26660	PLATE	1				0.004	0.0088
012	05122-50835	PIN,JOINT	1				0.015	0.033
013	04015-50060	WASHER,PLAIN	1				0	0
014	01202-50610	BOLT	1				0.004	0.0088
015	05411-00630	PIN,SPRING	1				0.004	0.0088
016	09500-16287	SEAL,OIL	2				0.01	0.022
017	38220-26710	SHAFT,DIFF GEAR RH	1	≤10574		(2WD)	2.6	5.72
017	35260-26710	SHAFT,DIFF GEAR RH	1	≥10575		(2WD)	2.6	5.72
017	38220-26710	SHAFT,DIFF GEAR RH	1	≤10491		(4WD)	2.6	5.72
017	35260-26710	SHAFT,DIFF GEAR RH	1	≥10492		(4WD)	2.6	5.72
018	38220-26720	SHAFT,DIFF GEAR LH	1	≤10574		(2WD)	2.8	6.16
018	35260-26720	SHAFT,DIFF GEAR LH	1	≥10575		(2WD)	2.9	6.38
018	38220-26720	SHAFT,DIFF GEAR LH	1	≤10491		(4WD)	2.8	6.16
018	35260-26720	SHAFT,DIFF GEAR LH	1	≥10492		(4WD)	2.9	6.38
019	08101-06307	BEARING,BALL	1				0.44	0.968

REAR AXLE

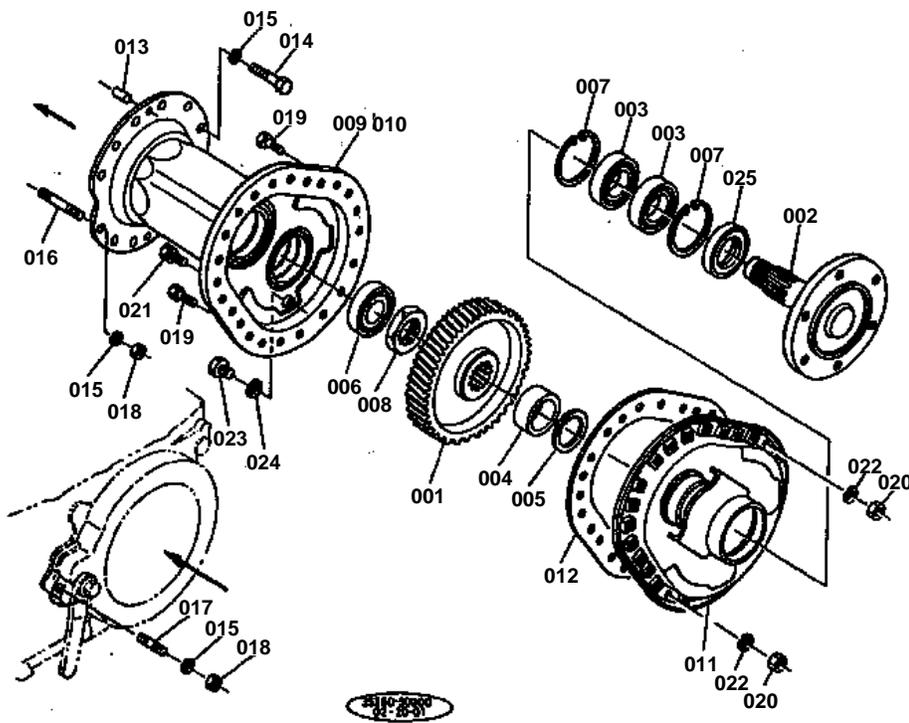

REF. No. ① 35200-2883-0

① 12"

① 35200-2885-0



REAR AXLE

↔ Interchangeable; ≠ not interchangeable; ← new for old; → old for new

REF.No	Part No.	Description	Q'ty	S.No.	I/C	REMARKS	Weight (kgf)	Weight (lb)
001	35260-26830	53 GEAR	2	<=10574		(2WD)	5.3	11.66
001	35260-26950	52 GEAR	2	>=10575		(2WD)	5.3	11.66
001	35260-26830	53 GEAR	2	<=10491		(4WD)	5.3	11.66
001	35260-26950	52 GEAR	2	>=10492		(4WD)	5.3	11.66
002	35260-27110	AXLE,REAR	2				8.1	17.82
003	08101-06209	BEARING,BALL	4				0.42	0.924
004	35210-99450	COLLAR	2				0.1	0.22
005	34150-27160	SHIM	2				0.01	0.022
006	08101-06307	BEARING,BALL	2				0.44	0.968
007	04611-00850	CIR-CLIP,INTERNAL	4				0.029	0.0638
008	70650-11380	NUT 40	2				0.11	0.242
009	35260-27310	CASE,AXLE RH	1				14.2	31.24
010	35260-27320	CASE,AXLE LH	1				15.3	33.66
011	35210-99490	COVER,AXLE CASE	2				7	15.4
012	37150-27340	GASKET	2				0	0
013	38260-28180	PIN,STRAIGHT	4				0.02	0.044
014	01173-51275	BOLT	8				0.071	0.1562
015	04512-50120	WASHER,SPRING	26				0	0
016	37300-27350	STUD	16				0.07	0.154
017	01574-51240	STUD	2				0	0
018	35340-27360	NUT	18				0.015	0.033
019	37150-27390	BOLT,REAMER	4				0.02	0.044
020	02118-50100	NUT	4				0.005	0.011
021	01133-51020	BOLT	42				0.02	0.044
022	04512-50100	WASHER,SPRING	4				0	0
023	38240-27350	PLUG	2				0.04	0.088
024	04717-01600	WASHER,SEAL	2				0.003	0.0066
025	37150-27560	SEAL,OIL	2				0.14	0.308

TRANSMISSION CASE

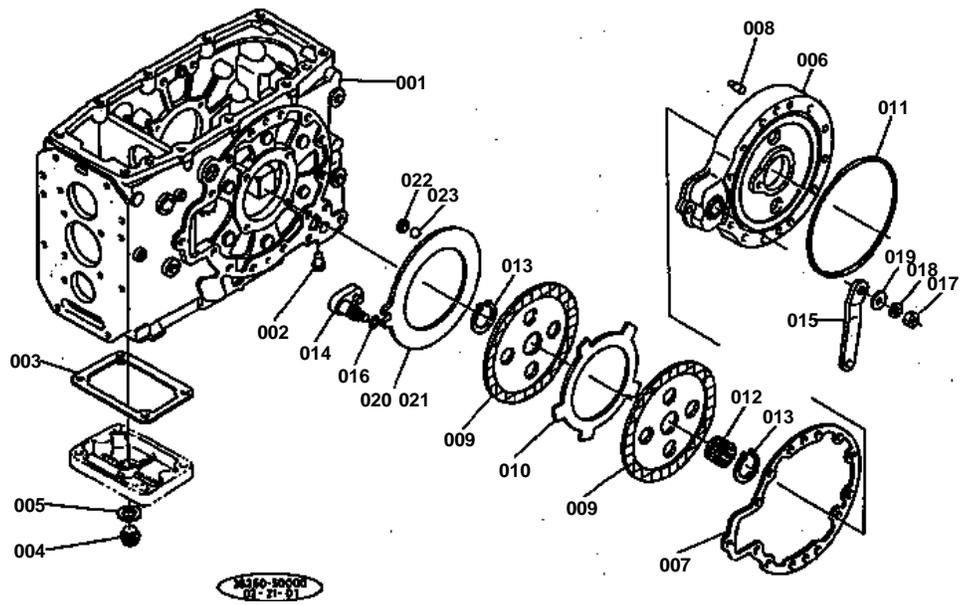



TRANSMISSION CASE

↔ Interchangeable; ≠ not interchangeable; ← new for old; → old for new

REF.No	Part No.	Description	Q'ty	S.No.	I/C	REMARKS	Weight (kgf)	Weight (lb)
001	35260-21110	CASE,TRANSMISSION	1				33.2	73.04
002	31220-14290	PLUG	4				0.002	0.0044
003	37150-21282	GASKET	1				0	0
004	06331-35012	PLUG	1				0.022	0.0484
005	04717-01200	WASHER,PLAIN	1				0.002	0.0044
006	37300-28150	CASE,BRAKE	2				6.9	15.18
007	37260-28160	GASKET	2				0	0
008	38260-28180	PIN,STRAIGHT	4				0.02	0.044
009	37150-28200	DISK,BRAKE	4				0.774	1.7028
010	37720-28170	PLAT	2				0.422	0.9284
011	37300-27440	O RING	2				0.01	0.022
012	37720-28190	BOSS,SPLINE	2				0.116	0.2552
013	04612-00450	CIR-CRIP,EXTERNAL	4				0.007	0.0154
014	37720-28216	CAM,BRAKE	2				0.34	0.748
015	37720-28220	LEVER,CAMSHAFT	2				0.28	0.616
016	04811-00180	O RING	2				0.001	0.0022
017	02174-50120	NUT	2				0.01	0.022
018	04512-50120	WASHER,SPRING	2				0	0
019	04013-50120	WASHER,PLAIN	2				0	0
020	37150-28240	PLATE,CAM LH	1				1.13	2.486
021	37150-28270	PLATE,CAM RH	1				1.08	2.376
022	37150-28250	SEAT,BALL	12				0.003	0.0066
023	07715-00805	BALL	12				0.016	0.0352

BRAKE PEDAL

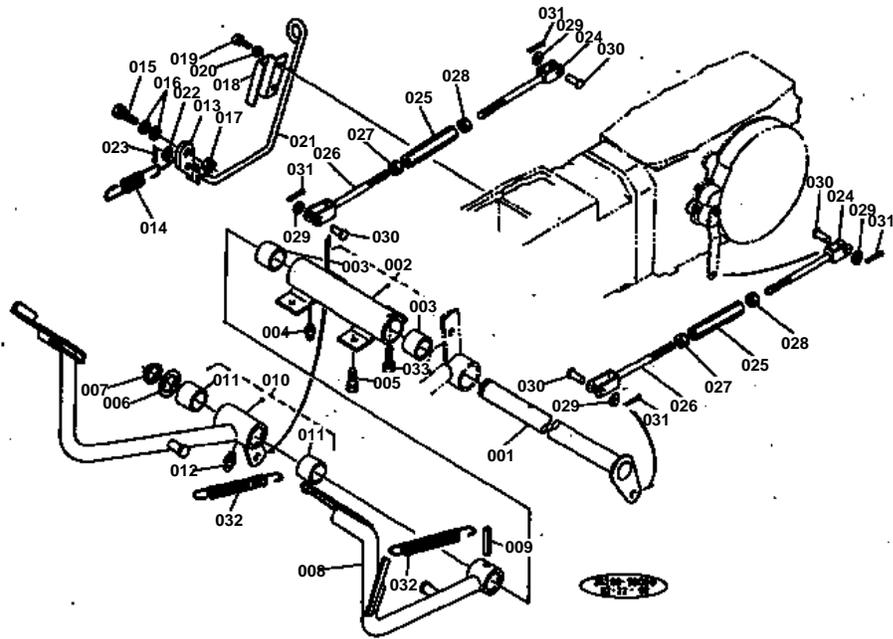

**BRAKE PEDAL**

↔ Interchangeable; ≠ not interchangeable; ← new for old; → old for new

REF.No	Part No.	Description	Q'ty	S.No.	I/C	REMARKS	Weight (kgf)	Weight (lb)
001	37150-28410	SHAFT,BRAKE PEDAL	1				1.43	3.146
002	37150-28420	SUPPORT,PEDAL SHAFT	1				0.95	2.09
003	34150-28430	BUSH	2				0.04	0.088
004	06613-10675	NIPPLE,GREASE	1				0.003	0.0066
005	01133-51020	BOLT	4	>=10001			0.02	0.044
005	01133-51020	BOLT	2	>=10001			0.02	0.044
006	32150-28460	COLLAR	1				0.007	0.0154
007	04612-00250	CIR-CLIP,EXTERNAL	1				0.002	0.0044
008	35260-28610	PEDAL,BRAKE LH	1				1.36	2.992
009	05411-00840	PIN,SPRING	1				0.008	0.0176
010	35260-28620	PEDAL,BRAKE RH	1				1.34	2.948
011	34150-28430	BUSH	2				0.04	0.088
012	06613-10675	NIPPLE,GREASE	1				0.003	0.0066
013	34150-28810	RATCHET	1				0.045	0.099
014	37150-28850	SPRING	1				0.005	0.011
015	34150-28820	BOLT	1				0.04	0.088
016	04011-50120	WASHER,PLAIN	2				0.005	0.011
017	02174-50120	NUT	1				0.01	0.022
018	34150-28880	GUIDE,RATCHET	1				0.04	0.088
019	01150-50812	BOLT	2				0.009	0.0198
020	04512-50080	WASHER,SPRING	2				0.001	0.0022
021	35260-28870	ROD,RATCHET	1				0.09	0.198
022	04012-50060	WASHER,PLAIN	1				0.001	0.0022
023	05511-50212	PIN,SPLIT	1				0.001	0.0022
024	37300-28930	ROD,BRAKE 1	2				0.23	0.506
025	37300-28980	TURNBUCKLE	2				0.15	0.33
026	37300-28940	ROD,BRAKE 2	2				0.23	0.506
027	37300-28990	NUT	2				0.015	0.033
028	02174-50140	NUT	2				0.014	0.0308
029	04012-50080	WASHER,PLAIN	4				0.001	0.0022
030	05112-50825	PIN,JOINT	4				0.011	0.0242
031	05511-50215	PIN,SPLIT	4				0.001	0.0022
032	37150-15840	SPRING	2				0.06	0.132
033	01133-51025	BOLT	2	>=10001		(2WD)	0.023	0.0506
033	01133-51025	BOLT	2	>=10001		(4WD)	0.023	0.0506

STEP

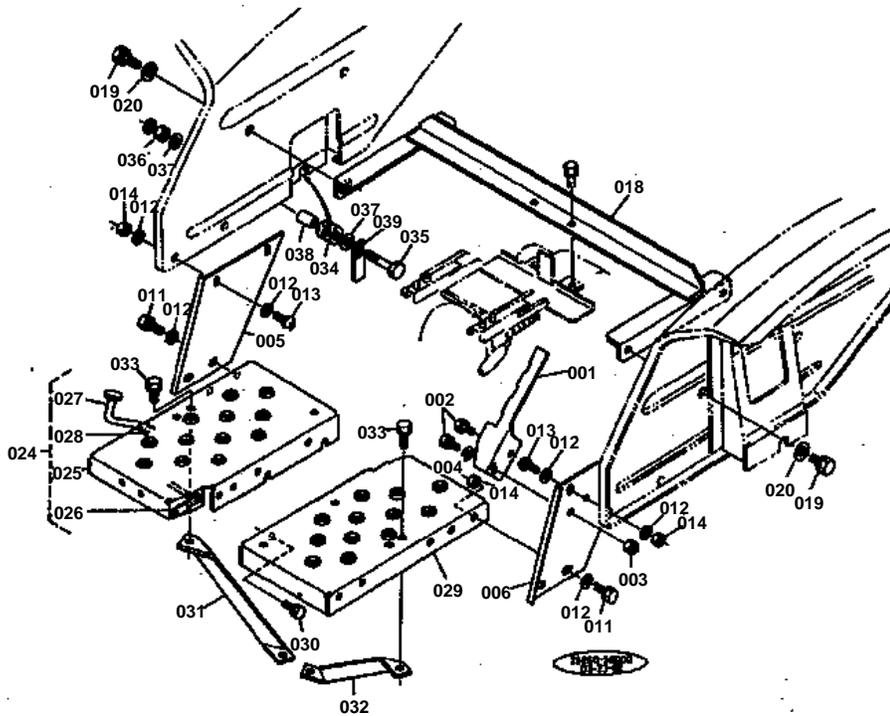

- REF. No. ① 35200-2214-0
② 35200-2216-0
③ 01130-00020
④ 35200-2202-0
⑤ 01130-01000
⑥ 04013-00100
⑦ 35200-2200-0
⑧ 35200-2201-0
⑨ 35200-2202-0
⑩ 35200-2204-0
⑪ 35200-2205-0
⑫ 02174-00120
⑬ 04012-00120
⑭ 35200-2221-0
⑮ 35200-2201-0
⑯ 04015-00000
⑰ 34150-1010-0
⑱ 35200-2203-0
⑲ 35200-2205-0

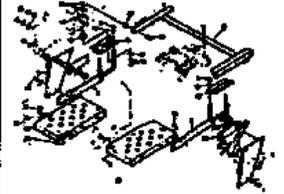



STEP

↔ Interchangeable; ≠ not interchangeable; ← new for old; → old for new

REF.No	Part No.	Description	Q'ty	S.No.	I/C	REMARKS	Weight (kgf)	Weight (lb)
001	35260-29180	GUIDE,AUX S-CHANGE L	1				0.175	0.385
002	01120-50816	BOLT	2				0	0
003	02114-50080	NUT	2				0.005	0.011
004	04013-50080	WASHER,PLAIN	1				0	0
005	35200-29140	FENDER,RH	1	≤10454		(2WD)	0.55	1.21
005	35260-29140	FENDER,RH	1	≥10455		(2WD)	0.72	1.584
005	35200-29140	FENDER,RH	1	≤10431		(4WD)	0.55	1.21
005	35260-29140	FENDER,RH	1	≥10432		(4WD)	0.72	1.584
006	35200-29160	FENDER,LH	1	≤10454		(2WD)	0.53	1.166
006	35260-29160	FENDER,LH	1	≥10455		(2WD)	0.405	0.891
006	35200-29160	FENDER,LH	1	≤10431		(4WD)	0.53	1.166
006	35260-29160	FENDER,LH	1	≥10432		(4WD)	0.405	0.891
007	35260-29040	BOLT RH	1	≤10454		(2WD)	0.95	2.09
007	35260-29040	BOLT RH	1	≤10431		(4WD)	0.95	2.09
008	35260-29060	BOLT LH	1	≤10454		(2WD)	0.99	2.178
008	35260-29060	BOLT LH	1	≤10431		(4WD)	0.99	2.178
009	02174-50120	NUT	1	≤10454		(2WD)	0.01	0.022
009	02174-50120	NUT	1	≤10431		(4WD)	0.01	0.022
010	04512-50120	WASHER,SPRING	1	≤10454		(2WD)	0	0
010	04512-50120	WASHER,SPRING	1	≤10431		(4WD)	0	0
011	01120-50825	BOLT	4	≤10454		(2WD)	0	0
011	01120-50820	BOLT	4	≥10455		(2WD)	0	0
011	01120-50825	BOLT	4	≤10431		(4WD)	0	0
011	01120-50820	BOLT	4	≥10432		(4WD)	0	0
012	04015-50080	WASHER,PLAIN	20				0	0
013	03004-50820	SCREW,WITH WASHER	8				0.011	0.0242
014	02114-50080	NUT	12				0.005	0.011
015	35200-29210	SPACER,FENDER	2	≤10454		(2WD)	0.8	1.76
015	35200-29210	SPACER,FENDER	2	≤10431		(4WD)	0.8	1.76
016	35200-29010	DAMPER	4	≤10454		(2WD)	0.095	0.209
016	35200-29010	DAMPER	4	≤10431		(4WD)	0.095	0.209
017	04015-50080	WASHER,SPRING	8	≤10454		(2WD)	0	0
017	04015-50080	WASHER,SPRING	8	≤10431		(4WD)	0	0
018	35260-29020	LINK,FENDER SUPPORT	1	≤10454		(2WD)	1.58	3.476
018	35260-29023	LINK,FENDER SUPPORT	1	≥10455		(2WD)	2.38	5.236
018	35260-29020	LINK,FENDER SUPPORT	1	≤10431		(4WD)	1.58	3.476
018	35260-29023	LINK,FENDER SUPPORT	1	≥10432		(4WD)	2.38	5.236
019	01130-51025	BOLT	4	≤10454		(2WD)	0	0
019	01130-51020	BOLT	4	≥10455		(2WD)	0	0
019	01130-51025	BOLT	4	≤10431		(4WD)	0	0
019	01130-51020	BOLT	4	≥10432		(4WD)	0	0
020	04013-50100	WASHER,PLAIN	4	≤10454		(2WD)	0	0
020	04015-50100	WASHER,PLAIN	4	≥10455		(2WD)	0.016	0.0352
020	04013-50100	WASHER,PLAIN	4	≤10431		(4WD)	0	0
020	04015-50100	WASHER,PLAIN	4	≥10432		(4WD)	0.016	0.0352
021	34150-18180	CUSHION	8	≤10454		(2WD)	0.003	0.0066
021	34150-18180	CUSHION	8	≤10431		(4WD)	0.003	0.0066
022	35260-29030	U NUT	4	≤10454		(2WD)	0.01	0.022
022	35260-29030	U NUT	4	≤10431		(4WD)	0.01	0.022
023	35260-29050	SUPPORT	2	≤10454		(2WD)	0.1	0.22



STEP

↔ Interchangeable; ≠ not interchangeable; ← new for old; → old for new

REF.No	Part No.	Description	Q'ty	S.No.	I/C	REMARKS	Weight (kgf)	Weight (lb)
023	35260-29050	SUPPORT	2	≤10431		(4WD)	0.1	0.22
024	35260-29900	ASSY STEP RH	1	≤10454		(2WD)	0	0
024	35260-29902	ASSY STEP RH	1	≥10455		(2WD)	3.2	7.04
024	35260-29900	ASSY STEP RH	1	≤10431		(4WD)	0	0
024	35260-29902	ASSY STEP RH	1	≥10432		(4WD)	3.2	7.04
025	99999-99999	BLANK	1	≤10454		(2WD) ORDER BY REF.No.024	0	0
025	99999-99999	BLANK	1	≥10455		(2WD) ORDER BY REF.No.024	0	0
025	99999-99999	BLANK	1	≤10431		(4WD) ORDER BY REF.No.024	0	0
025	99999-99999	BLANK	1	≥10432		(4WD) ORDER BY REF.No.024	0	0
026	35260-29900	SHAFT,ACCEL PEDAL	1				0	0
027	99999-99999	BLANK	1			ORDER BY RFE.No.024	0	0
028	37150-17530	SPRING	1				0.01	0.022
029	35260-29920	STEP LH	1	≤10454		(2WD)	0	0
029	35260-29924	STEP LH	1	≥10455		(2WD)	2.85	6.27
029	35260-29920	STEP LH	1	≤10431		(4WD)	0	0
029	34260-29924	STEP LH	1	≥10432		(4WD)	0	0
030	01133-51016	BOLT	6				0.015	0.033
031	35260-29930	STEP SUPPORT RH	1	≥10455		(2WD)	0.26	0.572
031	35260-29930	STEP SUPPORT RH	1	≥10432		(4WD)	0.26	0.572
032	35260-29940	STEP SUPPORT LH	1	≥10455		(2WD)	0.255	0.561
032	35260-29940	STEP SUPPORT LH	1	≥10432		(4WD)	0.255	0.561
033	01123-50816	BOLT	2	≥10455		(2WD)	0.011	0.0242
033	01123-50816	BOLT	2	≥10432		(4WD)	0.011	0.0242
034	35260-29950	CUSHION	2	≥10455		(2WD)	0.02	0.044
034	35260-29950	CUSHION	2	≥10432		(4WD)	0.02	0.044
035	01173-51060	BOLT	2	≥10455		(2WD)	0.038	0.0836
035	01173-51060	BOLT	2	≥10432		(4WD)	0.038	0.0836
036	02118-50100	NUT	2	≥10455		(2WD)	0.005	0.011
036	02118-50100	NUT	2	≥10432		(4WD)	0.005	0.011
037	04013-50100	WASHER,PLAIN	4	≥10455		(2WD)	0	0
037	04013-50100	WASHER,PLAIN	4	≥10432		(4WD)	0	0
038	66591-41550	COLLAR	2	≥10455		(2WD)	0.02	0.044
038	66591-41550	COLLAR	2	≥10432		(4WD)	0.02	0.044
039	34150-29370	CLAMP,CORD	2	≥10455		(2WD)	0.005	0.011
039	34150-29370	CLAMP,CORD	2	≥10432		(4WD)	0.005	0.011

PANEL 1

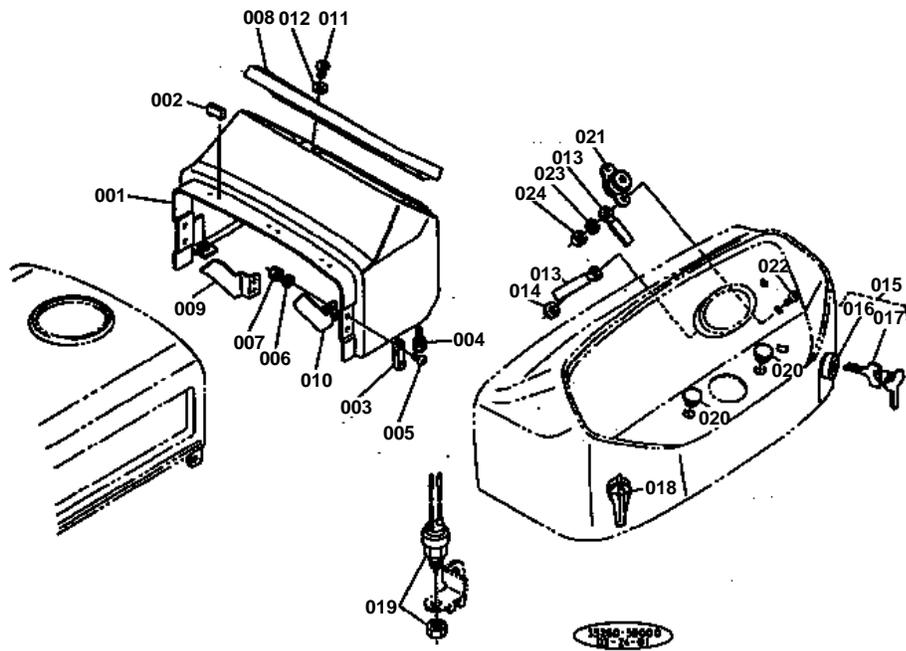



PANEL 1

↔ Interchangeable; ≠ not interchangeable; ← new for old; → old for new

REF.No	Part No.	Description	Q'ty	S.No.	I/C	REMARKS	Weight (kgf)	Weight (lb)
001	35260-31110	PANEL	1				2.6	5.72
002	33251-83490	CUSHION 1	3				0.008	0.0176
003	37150-18180	CUSHION	2				0.015	0.033
004	01120-50816	BOLT	4				0	0
005	03054-50514	SCREW,PAN HEAD	4				0.004	0.0088
006	04512-50050	WASHER,SPRING	4				0	0
007	02054-50050	NUT	4				0.002	0.0044
008	37150-31120	DASHBOARD	1				0.562	1.2364
009	37150-31180	GUIDE RH	1				0.07	0.154
010	37150-31190	GUIDE LH	1				0.065	0.143
011	34150-31140	SCREW,BINDING HEAD	4				0.009	0.0198
012	04013-50080	WASHER,PLAIN	4				0	0
013	34150-29390	CLAMP,CORD	2				0.004	0.0088
014	04013-50060	WASHER,PLAIN	1				0	0
015	35260-31800	ASSY SWITCH,MAIN	1				0.27	0.594
016	38180-31820	SWITCH,MAIN	1				0.25	0.55
017	35260-31850	ASSY KEY,MAIN SWITCH	1				0	0
018	38240-32100	SWITCH,LAMP	1				0.063	0.1386
019	37150-32240	SWITCH,SAFETY	1				0.12	0.264
020	35110-32420	PLUG	2				0.002	0.0044
021	15531-65950	INDICATOR,GLOW PLUG	1				0.05	0.11
022	03054-20510	SCREW,PAN HEAD	2				0	0
023	04512-50050	WASHER,SPRING	2				0	0
024	02054-50050	NUT	2				0.002	0.0044

PANEL 2

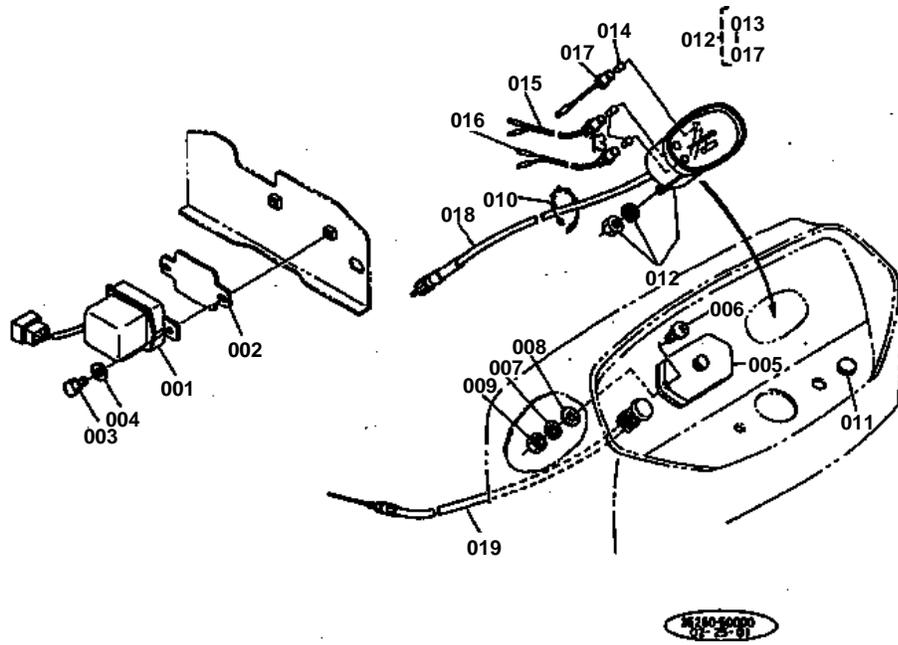



PANEL 2

↔ Interchangeable; ≠ not interchangeable; ← new for old; → old for new

REF.No	Part No.	Description	Q'ty	S.No.	I/C	REMARKS	Weight (kgf)	Weight (lb)
001	33251-74010	ASSY REGULATOR	1				0.35	0.77
002	37150-33420	COVER,REGULATOR	1				0.03	0.066
003	01020-50612	BOLT	2				0.005	0.011
004	04012-50060	WASHER,PLAIN	2				0.001	0.0022
005	35260-33600	CASE,FUSE	1				0.11	0.242
006	03024-50516	SCREW,WITH WASHER	2				0.004	0.0088
007	04512-50050	WASHER,SPRING	2				0	0
008	04012-50050	WASHER,PLAIN	2				0.001	0.0022
009	02054-50050	NUT	2				0.002	0.0044
010	34350-29380	CLAMP,CORD	1				0.001	0.0022
011	34159-32610	CAP	1				0	0
012	35260-34600	METER,TRACTOR	1				0	0
013	32150-31740	BULB,LAMP	2				0.003	0.0066
014	34150-34620	BULB,LAMP	1				0.001	0.0022
015	99999-99999	BLANK	1			ORDER BY REF.No.012	0	0
016	99999-99999	BLANK	1			ORDER BY REF.No.012	0	0
017	99999-99999	BLANK	1			ORDER BY REF.No.012	0	0
018	35300-34650	CABLE,TRACTOR METER	1				0.213	0.4686
019	35260-34700	WIRE,DECOMPRESS	1				0.115	0.253

HEAD LAMP

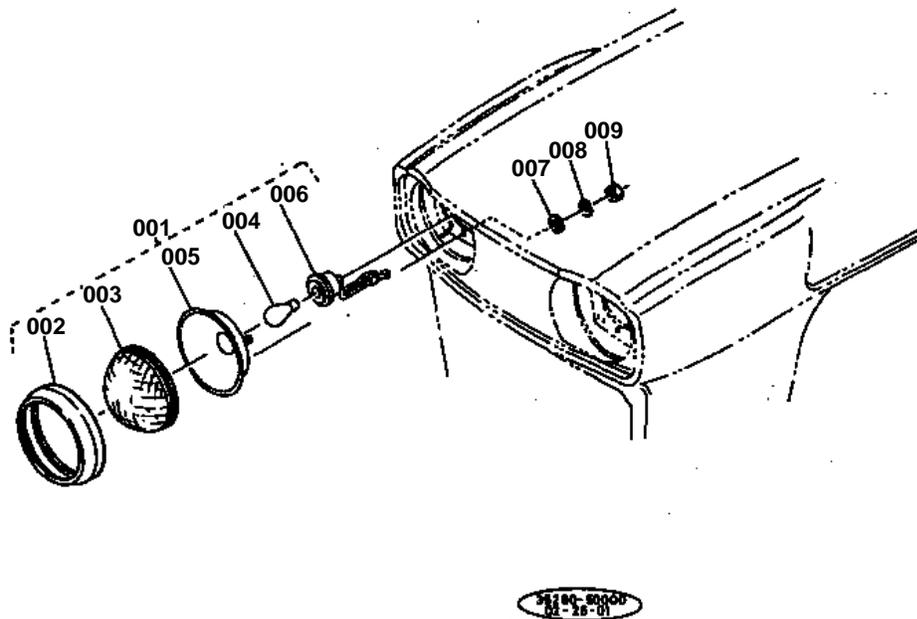



HEAD LAMP

↔ Interchangeable; ≠ not interchangeable; ← new for old; → old for new

REF.No	Part No.	Description	Q'ty	S.No.	I/C	REMARKS	Weight (kgf)	Weight (lb)
001	32240-33800	ASSY LAMP,HEAD	2				0.33	0.726
002	32240-33810	BODY	2				0.06	0.132
003	32280-33830	LENS	2				0.098	0.2156
004	32150-33840	LAMP	2				0.014	0.0308
005	33240-33870	REFLECTOR,LAMP	2				0	0
006	32280-33850	CUSHION	2				0.005	0.011
007	04013-50050	WASHER,PLAIN	6				0	0
008	04512-50050	WASHER,SPRING	6				0	0
009	02054-50050	NUT	6				0.002	0.0044

WIRING DIAGRAM

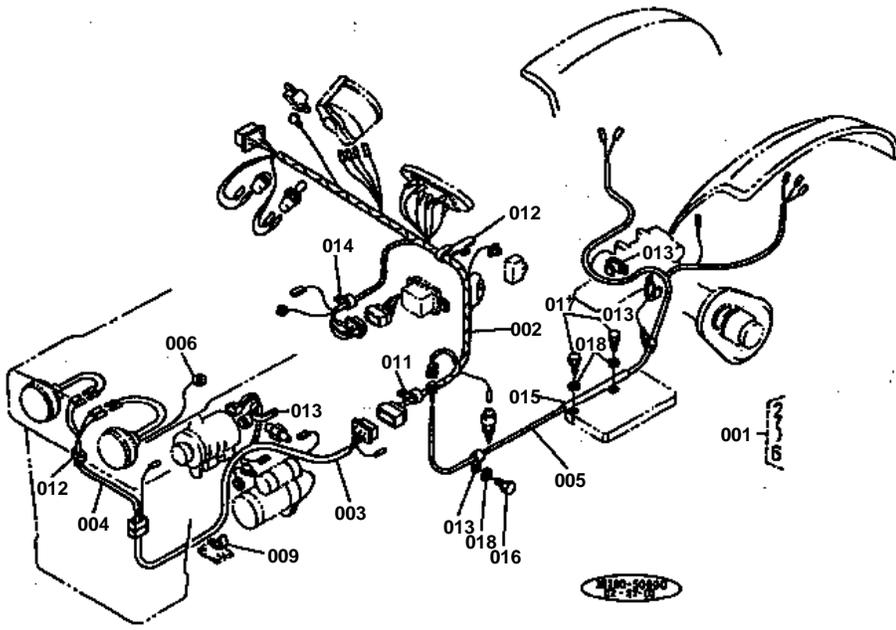

REF. No. ① 04011-50100
② 30280-3437-0
③ 34180-2838-0

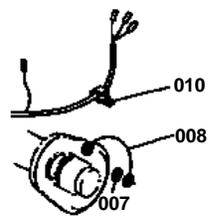

Discontinuas.



WIRING DIAGRAM

↔ Interchangeable; ≠ not interchangeable; ← new for old; → old for new

REF.No	Part No.	Description	Q'ty	S.No.	I/C	REMARKS	Weight (kgf)	Weight (lb)
001	35260-34402	ASSY WIRE HARNESS	1				0	0
002	35260-34410	WIRE HARNESS 1	1				0.4	0.88
003	35260-34320	WIRE HARNESS 2	1				0.17	0.374
004	35110-34330	WIRE HARNESS 3	1				0.035	0.077
005	35260-34350	WIRE HARNESS 5	1				0.13	0.286
006	35110-34350	CORD,HEAD LAMP EARTH	1				0.005	0.011
007	04011-50100	WASHER,PLAIN	2	<=10454		(2WD)	0.002	0.0044
007	04011-50100	WASHER,PLAIN	2	<=10431		(4WD)	0.002	0.0044
008	35260-34370	CORD,EARTH	2	<=10454		(2WD)	0.003	0.0066
008	35260-34370	CORD,EARTH	2	<=10431		(4WD)	0.003	0.0066
009	37150-34460	CLAMP,CORD	4				0.03	0.066
010	34150-29390	CLAMP,CORD	2	<=10454		(2WD)	0.004	0.0088
010	34150-29390	CLAMP,CORD	2	<=10431		(4WD)	0.004	0.0088
011	37150-34470	CLAMP,CORD	1				0.004	0.0088
012	32240-34482	CLAMP,CORD 1	2				0.008	0.0176
013	32240-34490	CLAMP,CORD 2	5				0.003	0.0066
014	34150-29390	CLAMP,CORD	1				0.004	0.0088
015	37150-34480	CLAMP,CORD	1				0.06	0.132
016	01123-50814	BOLT	1				0	0
017	01222-50812	BOLT	3				0.009	0.0198
018	04512-50080	WASHER,SPRING	3				0.001	0.0022

FUEL TANK

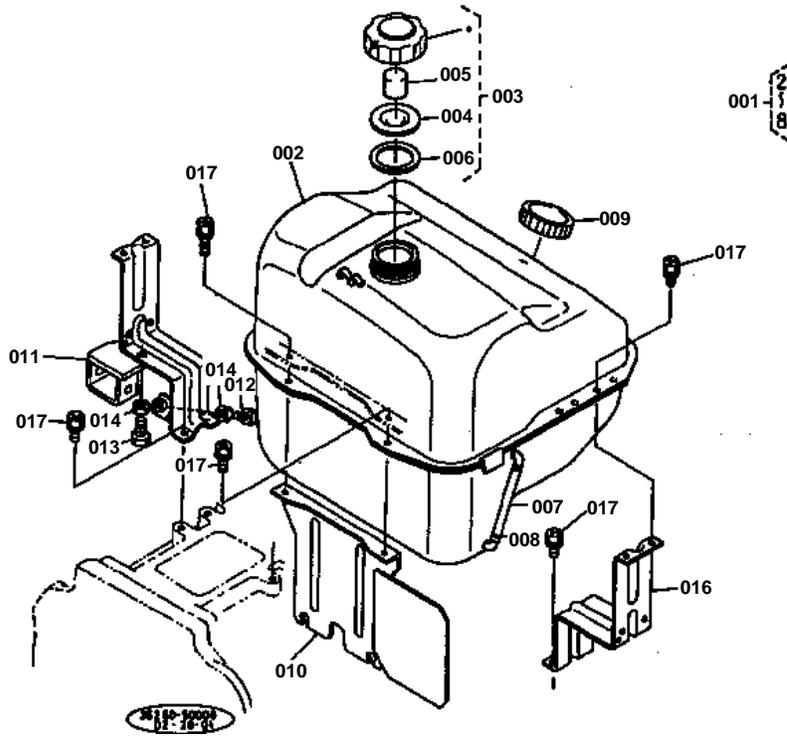



FUEL TANK

↔ Interchangeable; ≠ not interchangeable; ← new for old; → old for new

REF.No	Part No.	Description	Q'ty	S.No.	I/C	REMARKS	Weight (kgf)	Weight (lb)
001	35260-35100	ASSY TANK,FUEL	1				6.9	15.18
002	99999-99999	BLANK	1			ORDER BY REF.No.001	0	0
003	38240-35200	ASSY CAP	1				0.06	0.132
004	99999-99999	BLANK	1			ORDER BY REF.No.003	0	0
005	99999-99999	BLANK	1			ORDER BY REF.No.003	0	0
006	99999-99999	BLANK	1			ORDER BY REF.No.003	0	0
007	34150-35470	GAUGE,FUEL	1				0	0
008	10013-41770	CLIP,PIPE	2				0.005	0.011
009	37300-35550	BUSH,FUEL	1				0.014	0.0308
010	35260-35270	SUPPORT,FUEL TANK	1				0.8	1.76
011	35260-35280	STAY,FUEL TANK RH	1				0.845	1.859
012	01152-50835	BOLT	1				0.015	0.033
013	01152-50830	BOLT	1				0.014	0.0308
014	02112-50080	NUT	2				0.003	0.0066
015	99999-99999	BLANK	0				0	0
016	37150-35290	STAY,FUEL TANK LH	1				0.38	0.836
017	01202-50816	BOLT	10				0.012	0.0264

**FUEL FILTER**

↔ Interchangeable; ≠ not interchangeable; ← new for old; → old for new

REF.No	Part No.	Description	Q'ty	S.No.	I/C	REMARKS	Weight (kgf)	Weight (lb)
001	35260-35502	ASSY PIPE,FUEL 1	1				0	0
002	99999-99999	BLANK	1			ORDER BY REF.No.001	0	0
003	14301-42750	CLIP,PIPE	2				0.005	0.011
004	34200-35530	ASSY PIPE,FUEL 2	1				0.055	0.121
005	99999-99999	BLANK	1			ORDER BY REF.No.004	0	0
006	14301-42750	CLIP,PIPE	2				0.005	0.011
007	67111-58320	SPRING,PIPE	1				0.02	0.044
008	35260-35540	PIPE,FUEL 3	1				0.03	0.066
009	35260-35550	PIPE,FUEL 5	1				0.015	0.033
010	32240-34490	CLAMP,CORD	1				0.003	0.0066
011	10244-42320	CLIP,PIPE	4				0.001	0.0022
012	34350-29380	BAND,CORD	1				0.001	0.0022
013	15575-43010	ASSY FILTER,FUEL	1				0	0
014	15575-43110	ASSY BODY	1				0.18	0.396
015	04811-10290	O RING	1				0.001	0.0022
016	15521-93310	SCREW,WITH WASHER	2				0.004	0.0088
017	15221-43520	HANDLE,FILTER	1				0	0
018	15521-43150	RING,RETAINER	1				0.14	0.308
019	15521-43130	POT,FILTER	1				0.1	0.22
020	15521-43672	GASKET	1				0.001	0.0022
021	15521-43160	ELEMENT,FILTER	1				0.07	0.154
022	04811-50650	O RING	1				0.002	0.0044
023	15521-43552	RETAINER,HANDLE	1				0.01	0.022
024	15521-43930	SPRING	1				0.004	0.0088
025	04811-00160	O RING	1				0.001	0.0022
026	15521-43542	PLATE,THRUST	1				0.001	0.0022
027	15521-43282	JOINT	1				0.005	0.011
028	19271-87210	LABEL	1				0.001	0.0022
029	35260-35810	BRACKET,FILTER	1				0.12	0.264
030	01120-50825	BOLT	2				0	0
031	01120-50816	BOLT	2				0	0

OIL HYDRAULIC SYSTEM 1

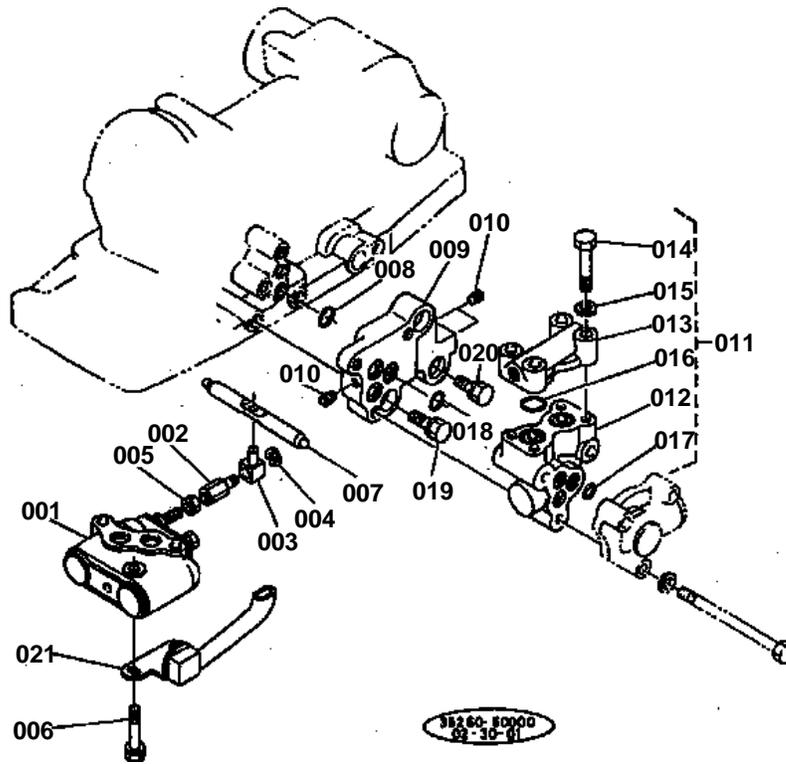



OIL HYDRAULIC SYSTEM 1

↔ Interchangeable; ≠ not interchangeable; ← new for old; → old for new

REF.No	Part No.	Description	Q'ty	S.No.	I/C	REMARKS	Weight (kgf)	Weight (lb)
001	38240-39140	VALVE,CONTROL	1				0	0
002	38240-36410	JOINT,SPOOL 1	1				0.035	0.077
003	37150-36420	JOINT,SPOOL 2	1				0.02	0.044
004	04613-00060	CIR-CLIP,EXTERNAL	1				0	0
005	02112-50080	NUT	1				0.003	0.0066
006	01123-50850	BOLT	3				0.02	0.044
007	38240-36430	LEVER,SPOOL DRIVE	1				0.065	0.143
008	04810-00100	O RING	3				0.001	0.0022
009	35260-36700	SPACER	1				0.77	1.694
010	06312-10010	PLUG	3				0.007	0.0154
011	35300-36700	ASSY BLOCK,OIL PRESS	1				2	4.4
012	35300-36710	BLOCK,OIL PRESSURE	1				1.6	3.52
013	35300-36720	COVER,OIL PRESSURE B	1				0.385	0.847
014	01153-50840	BOLT	4				0.018	0.0396
015	04512-50080	WASHER,SPRING	4				0.001	0.0022
016	04810-00200	O RING	2				0.001	0.0022
017	04810-00120	O RING	3				0.001	0.0022
018	04810-00120	O RING	3				0.001	0.0022
019	01120-50825	BOLT	2				0	0
020	01120-50822	BOLT	1				0	0
021	38240-39160	PIPE	1				0.135	0.297

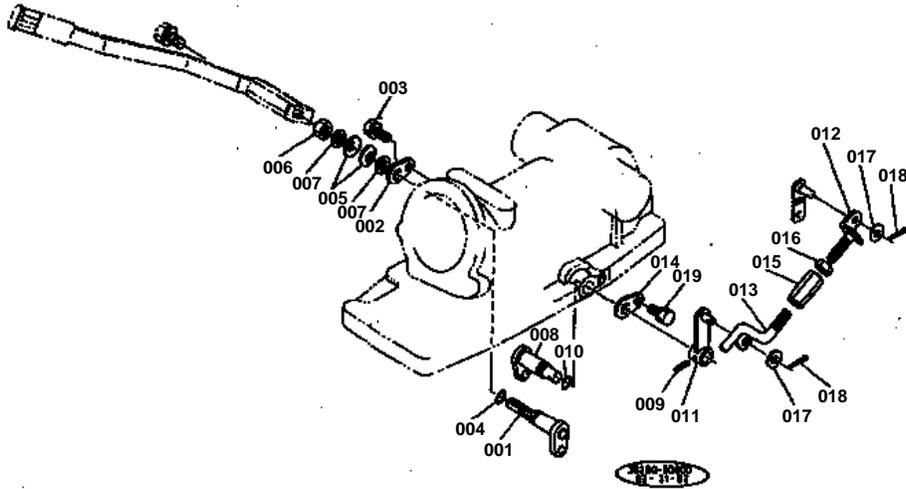



OIL HYDRAULIC SYSTEM 2

↔ Interchangeable; ≠ not interchangeable; ← new for old; → old for new

REF.No	Part No.	Description	Q'ty	S.No.	I/C	REMARKS	Weight (kgf)	Weight (lb)
001	38240-37650	ARM,CONTROL	1				0.11	0.242
002	38240-36890	PLATE,SET	1				0.013	0.0286
003	01123-50816	BOLT	1				0.011	0.0242
004	04811-00120	O RING	1				0.001	0.0022
005	34220-36880	SPRING	2				0.005	0.011
006	02174-50120	NUT	1				0.01	0.022
007	34220-36890	WASHER	2				0.006	0.0132
008	38240-37670	SHAFT,LEVER	1				0.1	0.22
009	05411-00420	PIN,SPRING	1				0.001	0.0022
010	04811-00120	O RING	1				0.001	0.0022
011	38240-37680	LEVER,FEEDBACK	1				0.05	0.11
012	38430-37760	ROD,CONTROL 1	1				0.025	0.055
013	38430-37770	ROD,CONTROL 2	1				0.04	0.088
014	38240-36890	PLATE,SET	1				0.013	0.0286
015	38430-37780	TURNBUCKLE	1				0.03	0.066
016	02112-50080	NUT	1				0.003	0.0066
017	04013-50080	WASHER,PLAIN	2				0	0
018	05511-50215	PIN,SPRIT	2				0.001	0.0022
019	01123-50816	BOLT	1				0.011	0.0242

OIL HYDRAULIC CYLINDER

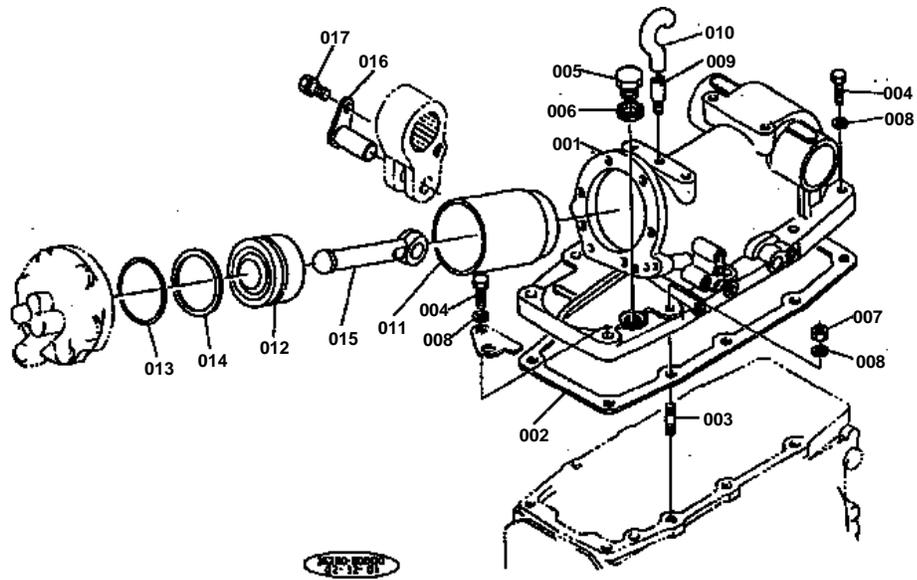



OIL HYDRAULIC CYLINDER

↔ Interchangeable; ≠ not interchangeable; ← new for old; → old for new

REF.No	Part No.	Description	Q'ty	S.No.	I/C	REMARKS	Weight (kgf)	Weight (lb)
001	35260-37110	CYLINDER,O/P	1				18	39.6
002	37150-37120	GASKET	1				0	0
003	01574-51240	STUD	2				0	0
004	01173-51245	BOLT	8				0.049	0.1078
005	06311-35030	PLUG	1				0.058	0.1276
006	04717-01700	WASHER,SEAL	1				0.003	0.0066
007	02176-50120	NUT	2				0.01	0.022
008	04512-50120	WASHER,SPRING	10				0	0
009	36200-21610	BREATHER 1	1				0.008	0.0176
010	36200-21620	BREATHER 2	1				0.006	0.0132
011	38240-37130	LINER,CYLINDER	1				1.36	2.992
012	38240-37310	PISTON,OIL PRESSURE	1				1.29	2.838
013	04811-00700	O RING	1				0.008	0.0176
014	32240-37330	RING,BACK UP	1				0.005	0.011
015	37300-37320	ROD,OIL PRESSURE	1				0.5	1.1
016	32240-37340	PIN,SET	1				0.2	0.44
017	01130-51018	BOLT	1				0	0

OIL HYDRAULIC CYLINDER COVER

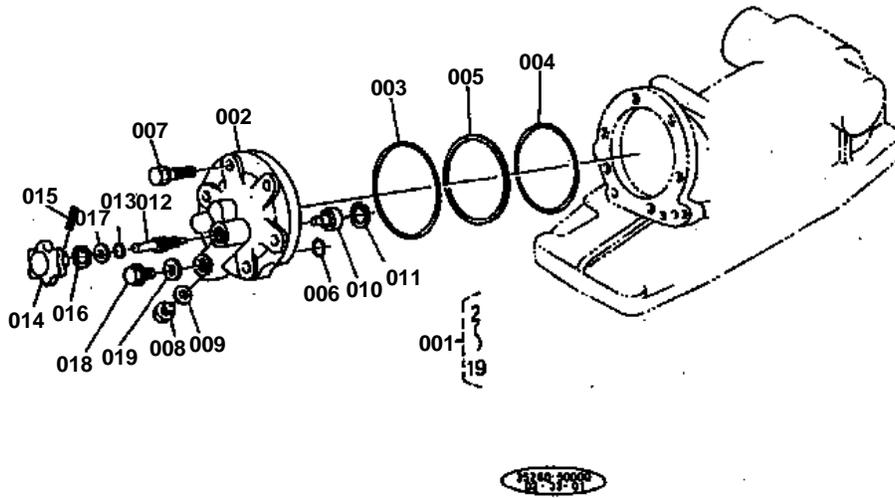



OIL HYDRAULIC CYLINDER COVER

↔ Interchangeable; ≠ not interchangeable; ← new for old; → old for new

REF.No	Part No.	Description	Q'ty	S.No.	I/C	REMARKS	Weight (kgf)	Weight (lb)
001	35260-37200	ASSY COVER,O/P CYL.F	1				3	6.6
002	38270-37210	COVER,O/P CYL.FRONT	1				2.5	5.5
003	04811-10950	O RING	1				0.002	0.0044
004	04810-50750	O RING	1				0.003	0.0066
005	32240-37260	RING,BACK UP	1				0.002	0.0044
006	04810-00140	O RING	1				0.001	0.0022
007	01133-51038	BOLT	6				0.03	0.066
008	37150-36740	PLUG	1				0.025	0.055
009	04724-00100	GASKET	1				0.001	0.0022
010	38240-37250	COLLAR,ADJUSTING	1				0.01	0.022
011	04611-00160	CIR-CLIP,INTERNAL	1				0.001	0.0022
012	38240-37220	SHAFT,O/P ADJ	1				0.025	0.055
013	04810-00100	O RING	1				0.001	0.0022
014	34150-37230	GRIP	1				0.04	0.088
015	05411-00418	PIN,SPRING	1				0.001	0.0022
016	34150-37260	CIR-CLIP,INTERNAL	1				0.001	0.0022
017	04012-50080	WASHER,PLAIN	1				0.001	0.0022
018	37150-36730	PLUG	1				0.03	0.066
019	04714-00200	GASKET	1				0.002	0.0044

LIFT ARM

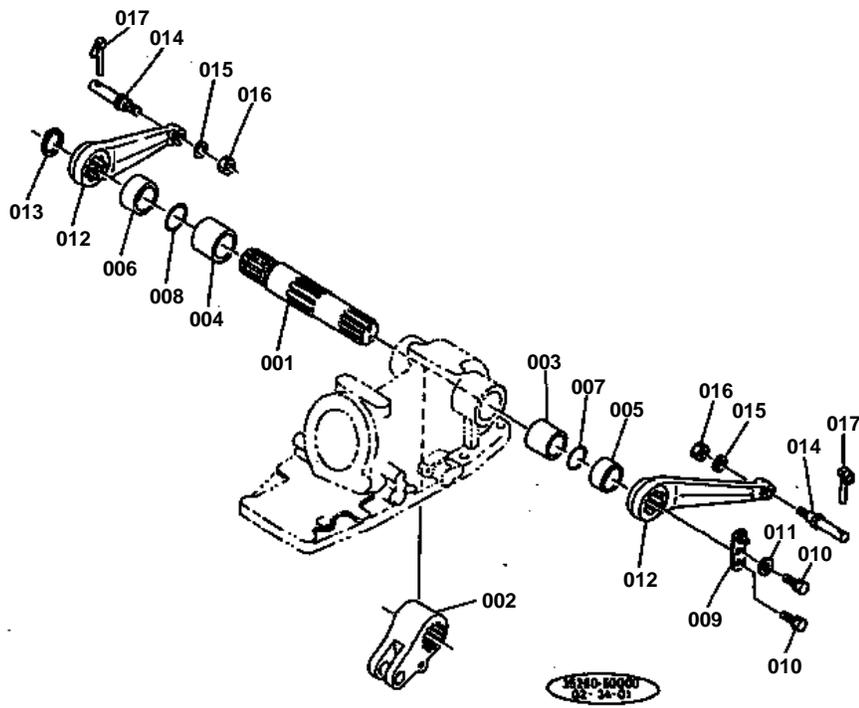



LIFT ARM

↔ Interchangeable; ≠ not interchangeable; ← new for old; → old for new

REF.No	Part No.	Description	Q'ty	S.No.	I/C	REMARKS	Weight (kgf)	Weight (lb)
001	38240-37430	SHAFT,O/P ARM	1				3.25	7.15
002	37220-37440	ARM,OIL PRESSURE	1				1.71	3.762
003	32240-37450	BUSH	1				0	0
004	32240-37460	BUSH	1				0	0
005	37300-37480	COLLAR	1				0.01	0.022
006	37300-37490	COLLAR	1				0.01	0.022
007	04811-50450	O RING	1				0.002	0.0044
008	04811-50500	O RING	1				0.001	0.0022
009	38240-37660	LINK,CONTROL	1				0.045	0.099
010	01123-50816	BOLT	2				0.011	0.0242
011	04013-50080	WASHER,PLAIN	1				0	0
012	38240-37613	ARM,LIFT	2				2.1	4.62
013	04612-00450	CIR-CLIP,EXTERNAL	1				0.007	0.0154
014	32240-37695	PIN,LIFT ROD	2				0.2	0.44
015	04512-50160	WASHER,SPRING	2				0	0
016	02174-50160	NUT	2				0.022	0.0484
017	34150-37640	PIN,SET	2				0.06	0.132

OIL HYDRAULIC PIPING

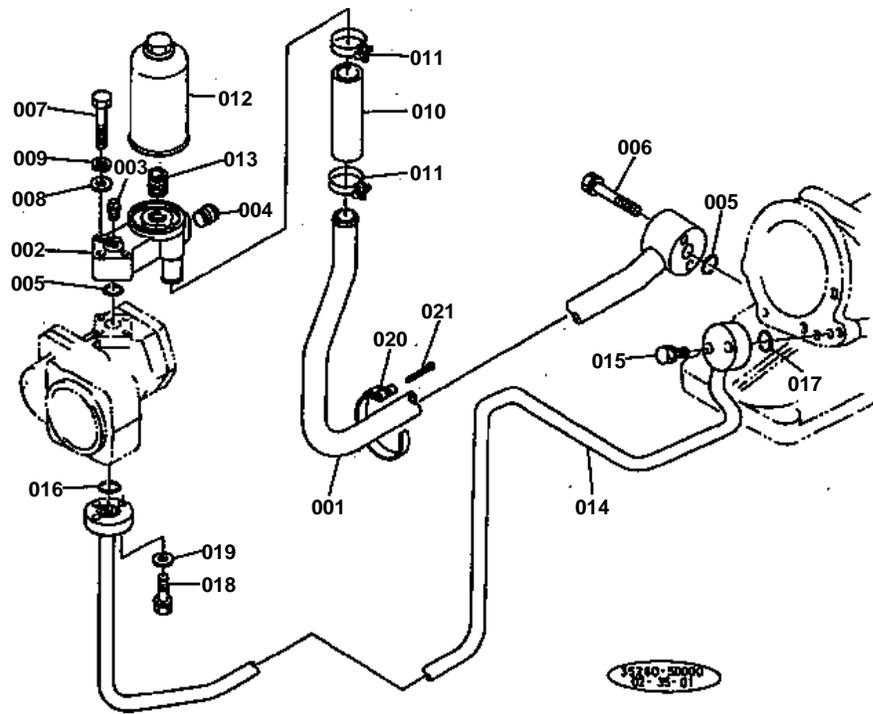



OIL HYDRAULIC PIPING

↔ Interchangeable; ≠ not interchangeable; ← new for old; → old for new

REF.No	Part No.	Description	Q'ty	S.No.	I/C	REMARKS	Weight (kgf)	Weight (lb)
001	35260-38120	ASSY PIPE,INLET	1				1.6	3.52
002	38240-37720	COVER,FILTER	1				0.405	0.891
003	06312-10010	PLUG	1				0.007	0.0154
004	06312-10030	PLUG	1				0.029	0.0638
005	04811-00200	O RING	2				0.001	0.0022
006	01123-50850	BOLT	2				0.02	0.044
007	01053-50645	BOLT	3				0.012	0.0264
008	04013-50060	WASHER,PLAIN	3				0	0
009	04512-50060	WASHER,SPRING	3				0	0
010	38240-37740	PIPE,RUBBER	1				0.065	0.143
011	34350-37780	CLAMP	2				0.02	0.044
012	38430-37710	CARTRIDGE,OIL FILTER	1				0.42	0.924
013	38240-37780	JOINT	1				0.03	0.066
014	35260-38210	ASSY PIPE,DELIVERY	1				0.975	2.145
015	01123-50830	BOLT	2				0.015	0.033
016	04810-00200	O RING	1				0.001	0.0022
017	04810-00120	O RING	1				0.001	0.0022
018	01023-50625	BOLT	3				0.007	0.0154
019	04013-50060	WASHER,PLAIN	3				0	0
020	33251-82760	BAND,O/P PIPE	2				0.016	0.0352
021	33430-82760	PIN	2				0.004	0.0088

DIFFERENTIAL SYSTEM

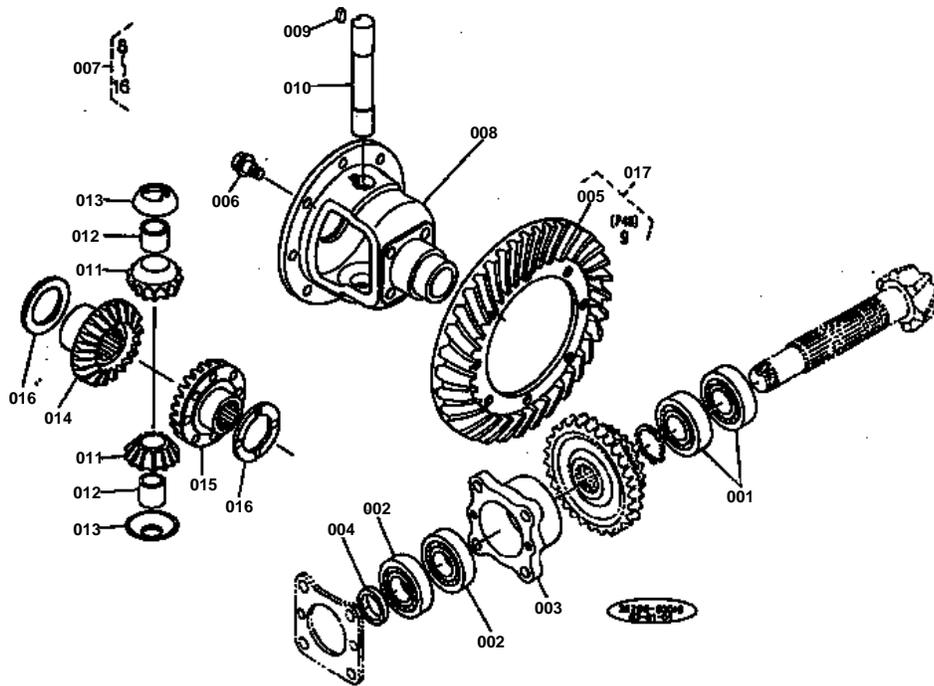



DIFFERENTIAL SYSTEM

↔ Interchangeable; ≠ not interchangeable; ← new for old; → old for new

REF.No	Part No.	Description	Q'ty	S.No.	I/C	REMARKS	Weight (kgf)	Weight (lb)
001	08101-06306	BEARING,BALL	2				0.335	0.737
002	08101-06305	BEARING,BALL	2				0.23	0.506
003	37150-22150	CASE,BEARING	1				0.55	1.21
004	37150-21770	COLLAR	1				0.12	0.264
005	99999-99999	BLANK	1			ORDER BY REF.No.017	0	0
006	37800-43870	BOLT	8				0.026	0.0572
007	35200-26100	ASSY DIFFERENTIAL	1				4.4	9.68
008	37150-26510	CASE,DIFF	1				0	0
009	31220-26280	KEY,FEATHER	1				0.005	0.011
010	31220-26340	SHAFT,DIFF PINION	1				0.31	0.682
011	31220-26300	PINION,DIFF	2				0.155	0.341
012	31220-26360	BUSH	2				0.015	0.033
013	31220-26390	WASHER,DIFF PINION	2				0	0
014	38440-44980	GEAR,DIFF SIDE RH	1				0	0
015	38180-26440	GEAR,DIFF SIDE LH	1				0.61	1.342
016	31220-26483	WASHER	2				0	0
016	31220-26493	WASHER	2				0	0
016	37150-26480	WASHER	2				0.016	0.0352
017	35110-22100	ASSY GEAR,SPIRAL BEV	1				5.3	11.66

DIFF BEARING CASE

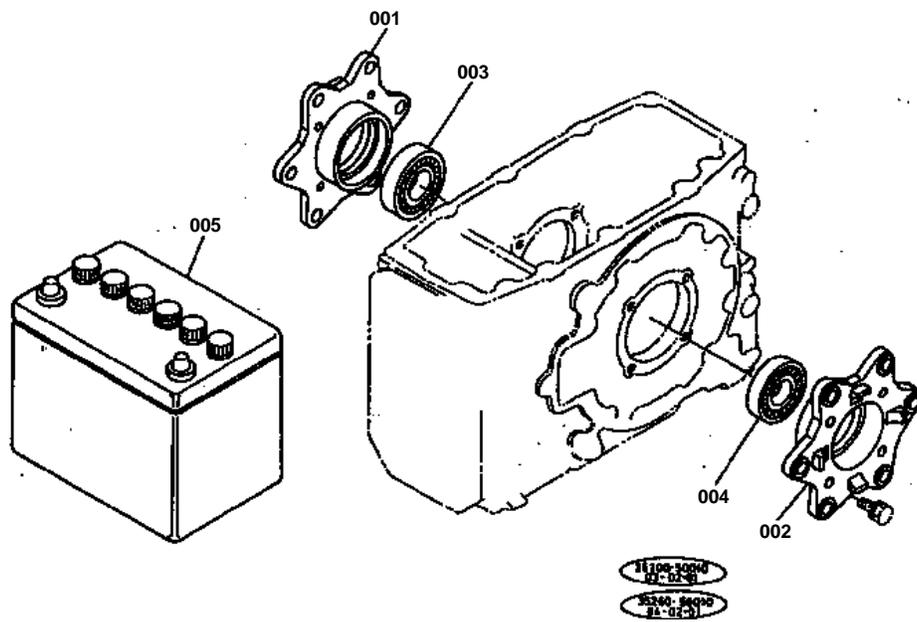



DIFF BEARING CASE

↔ Interchangeable; ≠ not interchangeable; ← new for old; → old for new

REF.No	Part No.	Description	Q'ty	S.No.	I/C	REMARKS	Weight (kgf)	Weight (lb)
001	37150-26550	CASE,BEARING RH	1				0	0
002	37150-26560	CASE,BEARING LH	1				0	0
003	08101-06210	BEARING,BALL	1				0.45	0.99
004	08101-06208	BEARING,BALL	1				0.355	0.781
005	35200-33200	DRY BATTERY	1				11.7	25.74
005	35260-33200	DRY BATTERY	1			(OPTIONAL)	14.2	31.24

3-POINT LINK 1

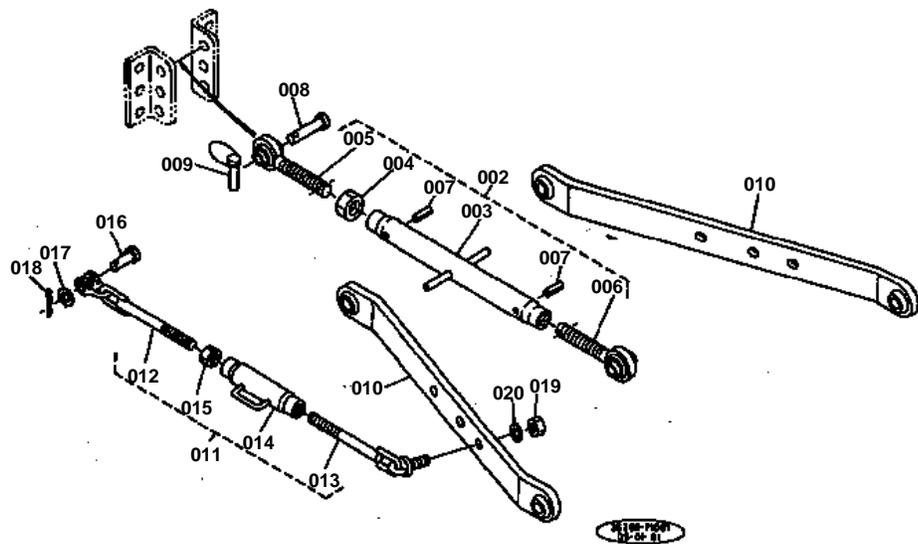



3-POINT LINK 1

↔ Interchangeable; ≠ not interchangeable; ← new for old; → old for new

REF.No	Part No.	Description	Q'ty	S.No.	I/C	REMARKS	Weight (kgf)	Weight (lb)
001	35260-71000	ASSY 3-POINT LINKAGE	1				0	0
002	99471-22100	ASSY LINK, TOP	1				2.91	6.402
003	32244-71110	LINK, TOP	1				1.01	2.222
004	32244-71180	NUT, TOP LINK	1				0.057	0.1254
005	35210-71210	JOINT, TOP LINK RH	1				0.985	2.167
006	35210-71220	JOINT, TOP LINK LH	1				1	2.2
007	05411-00425	PIN, SPRING	2				0.001	0.0022
008	31150-71360	PIN, JOINT	2				0.166	0.3652
009	34150-37640	PIN, SET	4				0.06	0.132
010	35260-71310	ASSY LINK, LOWER	2				6.6	14.52
011	35260-71800	ASSY CHAIN, CHECK	2				1.06	2.332
012	35260-71810	CHAIN, CHECK 1	2				0.43	0.946
013	35260-71820	CHAIN, CHECK 2	2				0.4	0.88
014	38187-71840	TURNBUCKLE	2				0.225	0.495
015	02052-50140	NUT	2				0.018	0.0396
016	32353-71890	PIN	2				0.041	0.0902
017	04013-50120	WASHER, PLAIN	2				0	0
018	05511-50425	PIN, SPLIT	2				0.003	0.0066
019	02074-50160	NUT	2				0.029	0.0638
020	04512-50160	WASHER, SPRING	2				0	0

3-POINT LINK 2

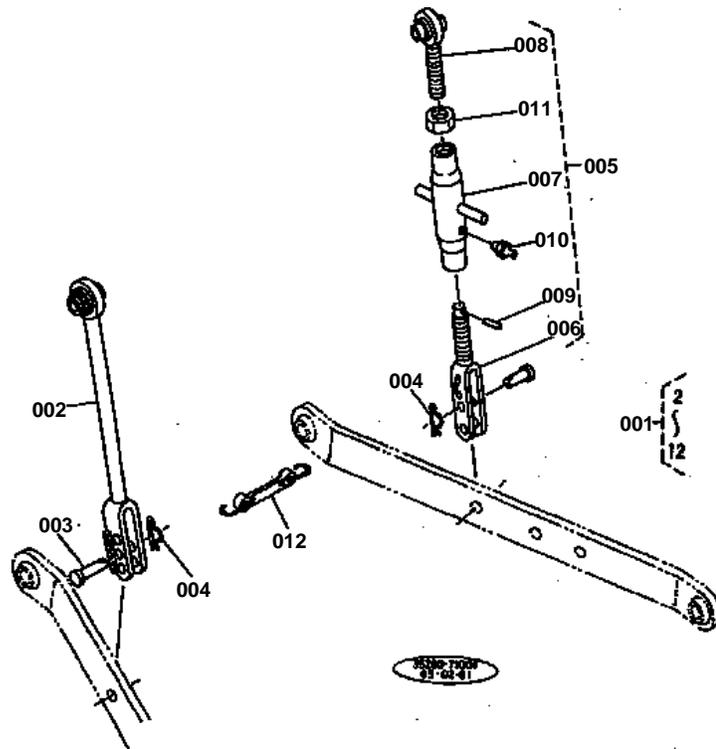



3-POINT LINK 2

↔ Interchangeable; ≠ not interchangeable; ← new for old; → old for new

REF.No	Part No.	Description	Q'ty	S.No.	I/C	REMARKS	Weight (kgf)	Weight (lb)
001	35260-71000	ASSY LINKAGE 3-POINT	1				0	0
002	35260-71540	ROD,LIFT LH	1				1.565	3.443
003	32353-71580	PIN,LIFT ROD	2				0.085	0.187
004	05515-51600	PIN,SNAP	2				0.007	0.0154
005	35260-71510	ASSY ROD,LIFT RH	1				2.05	4.51
006	35260-71520	ROD,LIFT	1				0.8	1.76
007	35260-71530	ROD,LIFT	1				0.645	1.419
008	35110-71552	ROD,LIFT	1				0.575	1.265
009	05411-00320	PIN,SPRING	1				0.001	0.0022
010	06613-10675	NIPPLE,GREASE	1				0.003	0.0066
011	35110-71570	NUT	1				0.05	0.11
012	38187-71750	RUBBER	1				0	0

FRONT WHEEL (4.00-15) [2WD]

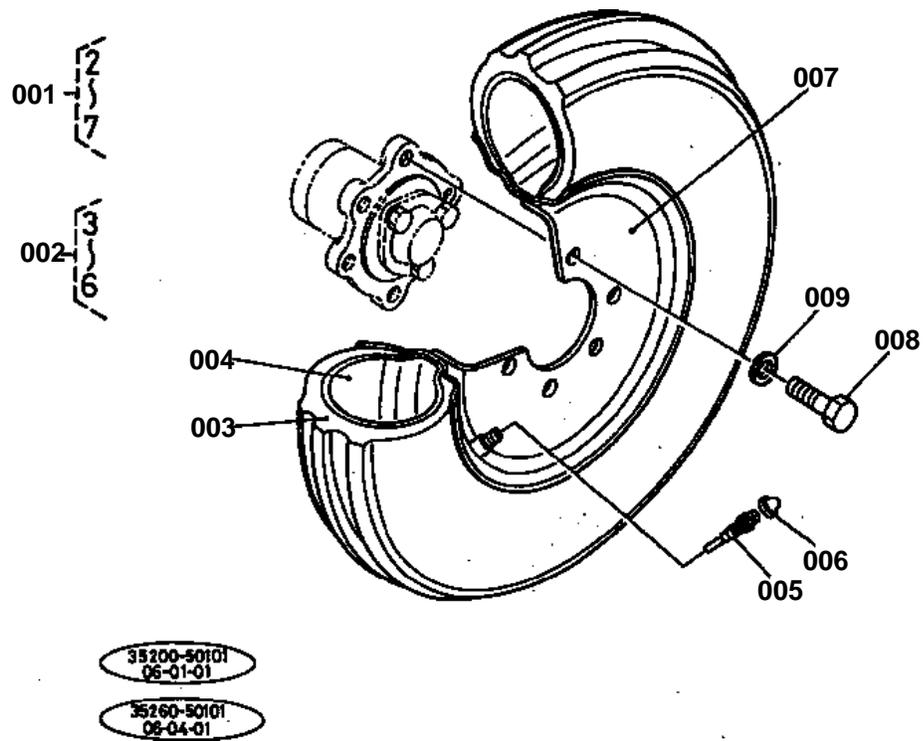



FRONT WHEEL (4.00-15) [2WD]

↔ Interchangeable; ≠ not interchangeable; ← new for old; → old for new

REF.No	Part No.	Description	Q'ty	S.No.	I/C	REMARKS	Weight (kgf)	Weight (lb)
001	35200-11600	ASSY FRONT WHEEL	2				13	28.6
002	35110-11610	ASSY TIRE	2				5	11
003	31220-11620	TIRE	2				3.5	7.7
004	31220-11630	TUBE	2				0.64	1.408
005	32270-11680	CORE,VALVE	2				0.02	0.044
006	38240-11690	CAP,VALVE	2				0.001	0.0022
007	35260-11640	ASSY WHEEL	2				6.5	14.3
008	01173-51425	BOLT	12				0.047	0.1034
009	04512-50140	WASHER,SPRING	12				0	0

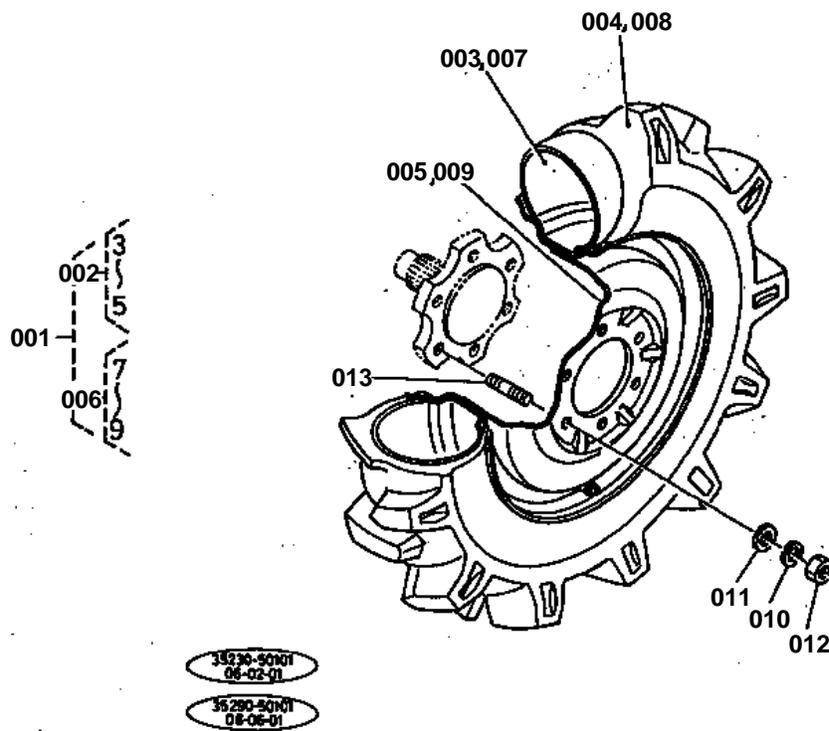

**FRONT WHEEL (6-14) [4WD]**

↔ Interchangeable; ≠ not interchangeable; ← new for old; → old for new

REF.No	Part No.	Description	Q'ty	S.No.	I/C	REMARKS	Weight (kgf)	Weight (lb)
001	35230-43700	ASSY FRONT WHEEL	1				36	79.2
002	35230-43710	ASSY FRONT WHEEL,RH	1				19	41.8
003	95016-11120	TUBE	1				0.77	1.694
004	38380-43740	TIRE	1				8.8	19.36
005	35230-43730	WHEEL	1				0	0
006	35230-43720	ASSY FRONT WHEEL,LH	1				19	41.8
007	95016-11120	TUBE	1				0.77	1.694
008	38380-43740	TIRE	1				8.8	19.36
009	35230-43730	WHEEL	1				0	0
010	04512-50140	WASHER,SPRING	12				0	0
011	04013-50140	WASHER,PLAIN	12				0	0
012	02176-50140	NUT	12				0.014	0.0308
013	01517-51425	STUD	12				0.047	0.1034

FRONT WHEEL (25X8.50-14) [4WD]

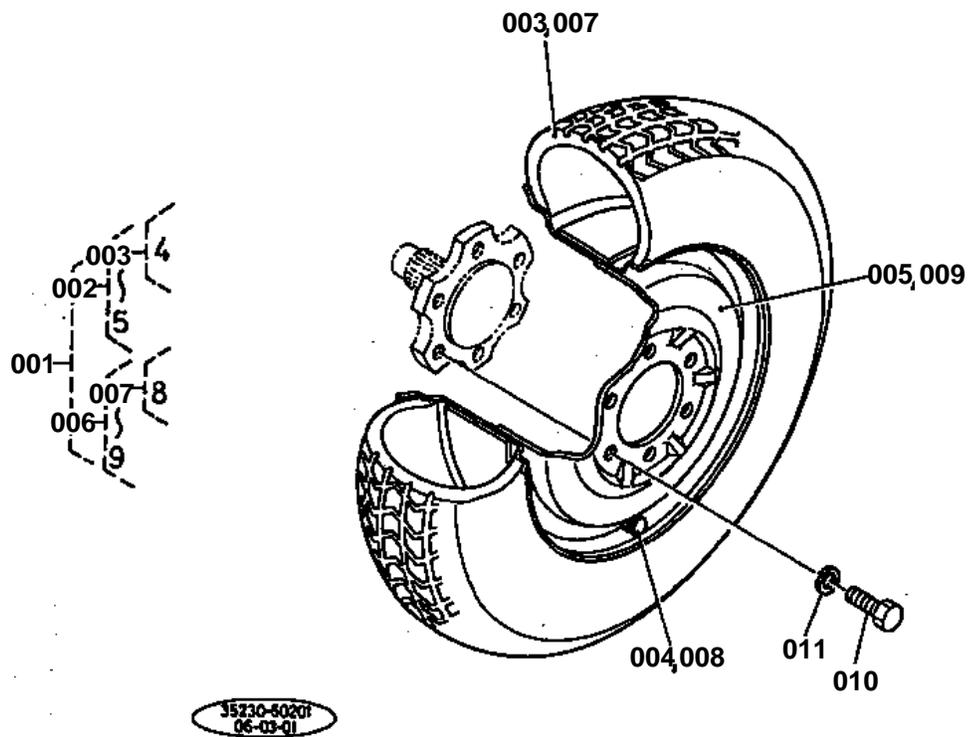



FRONT WHEEL (25X8.50-14) [4WD]

↔ Interchangeable; ≠ not interchangeable; ← new for old; → old for new

REF.No	Part No.	Description	Q'ty	S.No.	I/C	REMARKS	Weight (kgf)	Weight (lb)
001	35230-11800	ASSY FRONT WHEEL	1				37.5	82.5
002	35230-11820	ASSY FRONT WHEEL,RH	1				0	0
003	35230-11810	TIRE	1				8	17.6
004	34159-11850	VALVE,TIRE	1				0.013	0.0286
005	35230-11840	ASSY WHEEL	1				0	0
006	35230-11830	ASSY FRONT WHEEL,LH	1				0	0
007	35230-11810	TIRE	1				8	17.6
008	34159-11850	VALVE,TIRE	1				0.013	0.0286
009	35230-11840	ASSY WHEEL	1				0	0
010	01173-51425	BOLT	12				0.047	0.1034
011	04512-50140	WASHER,SPRING	12				0	0

FRONT WHEEL (23X8.50-12) [L235(2WD)/L275(4WD)]

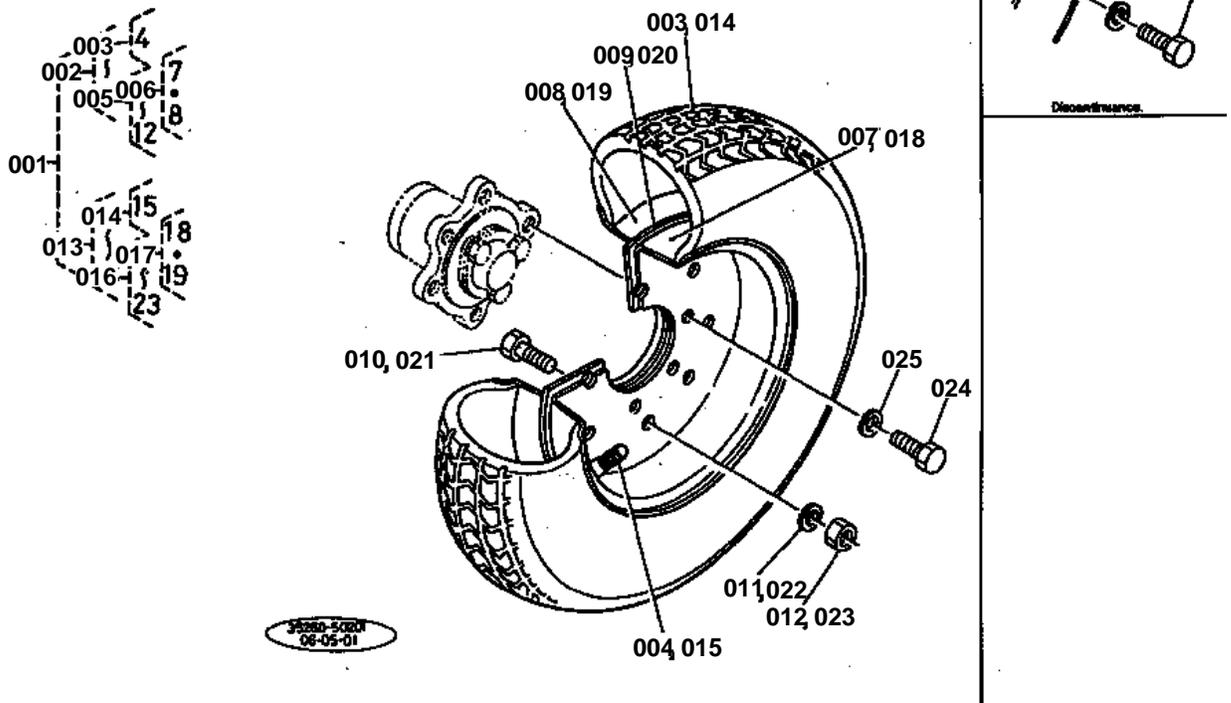



FRONT WHEEL (23X8.50-12) [L235(2WD)/L275(4WD)]

↔ Interchangeable; ≠ not interchangeable; ← new for old; → old for new

REF.No	Part No.	Description	Q'ty	S.No.	I/C	REMARKS	Weight (kgf)	Weight (lb)
001	35260-11800	ASSY FRONT WHEEL	1				34.4	75.68
001	35260-11802	ASSY FRONT WHEEL	1	>=10001			0	0
002	35260-11820	ASSY FRONT WHEEL,RH	1				17	37.4
002	35260-11822	ASSY FRONT WHEEL,RH	1	>=10001			0	0
003	35260-11810	TIRE	1				7.12	15.664
004	34159-11850	VALVE,TIRE	1				0.013	0.0286
005	35260-11840	ASSY WHEEL	1				10	22
005	35260-11842	ASSY WHEEL	1	>=10001			0	0
006	35260-11850	WHEEL	1				7	15.4
006	35260-11852	WHEEL	1	>=10001			0	0
007	35260-11870	RIM 1	1				5.6	12.32
008	35260-11880	RIM 2	1				3.7	8.14
009	35260-11860	GASKET	1				0.065	0.143
010	01170-51022	BOLT	8				0	0
011	04512-50100	WASHER,SPRING	8				0	0
012	02118-50100	NUT	8				0.005	0.011
013	35260-11830	ASSY FRONT WHEEL,LH	1				17	37.4
013	35260-11832	ASSY FRONT WHEEL,LH	1	>=10001			0	0
014	35260-11810	TIRE	1				7.12	15.664
015	34159-11850	VALVE,TIRE	1				0.013	0.0286
016	35260-11840	ASSY WHEEL	1				10	22
017	35260-11850	WHEEL	1				7	15.4
018	35260-11870	RIM 1	1				5.6	12.32
019	35260-11880	RIM 2	1				3.7	8.14
020	35260-11860	GASKET	1				0.065	0.143
021	01170-51022	BOLT	8				0	0
022	04512-50100	WASHER,SPRING	8				0	0
023	02118-50100	NUT	8				0.005	0.011
024	01173-51435	BOLT	12				0.056	0.1232
024	01173-51425	BOLT	12	>=10001			0.047	0.1034
025	04512-50140	WASHER,SPRING	12				0	0

REAR WHEEL (9.5-24)

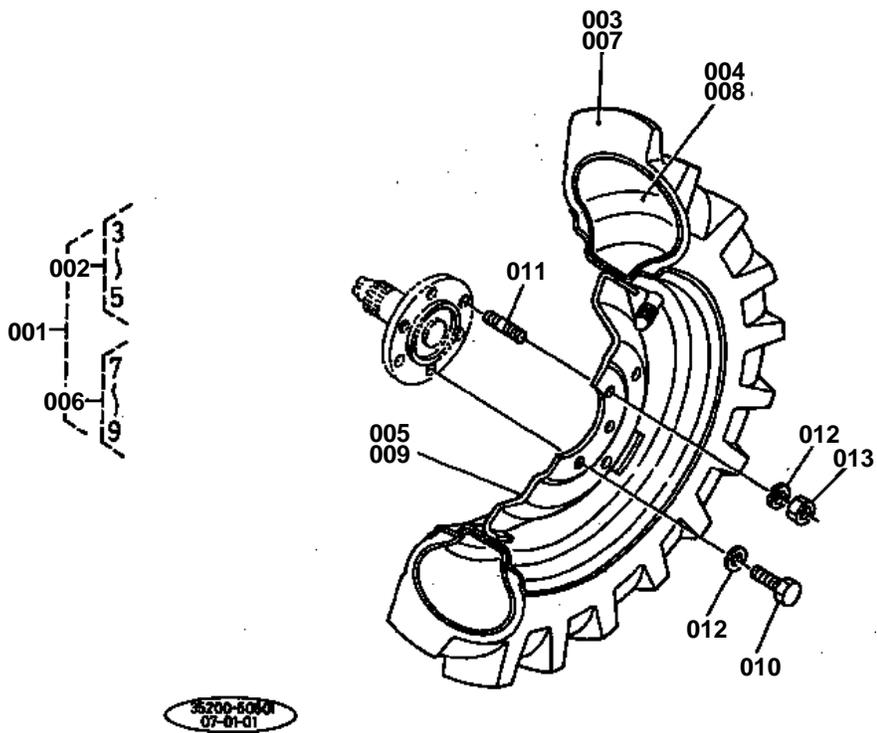

**REAR WHEEL (9.5-24)**

↔ Interchangeable; ≠ not interchangeable; ← new for old; → old for new

REF.No	Part No.	Description	Q'ty	S.No.	I/C	REMARKS	Weight (kgf)	Weight (lb)
001	35200-27902	ASSY REAR WHEEL	1				0	0
002	35200-27912	ASSY REAR WHEEL,LH	1				48	105.6
003	35200-27620	TIRE	1				24	52.8
004	31220-27630	TUBE	1				2.7	5.94
005	35200-27632	WHEEL	1				20.5	45.1
006	35200-27992	ASSY REAR WHEEL,RH	1				48	105.6
007	35200-27620	TIRE	1				24	52.8
008	31220-27630	TUBE	1				2.7	5.94
009	35200-27632	WHEEL	1				20.5	45.1
010	01073-51630	BOLT	12				0.079	0.1738
011	34150-27710	STUD	4				0.062	0.1364
012	04512-50160	WASHER,SPRING	16				0	0
013	02074-50160	NUT	4				0.029	0.0638

REAR WHEEL (13.6-16)

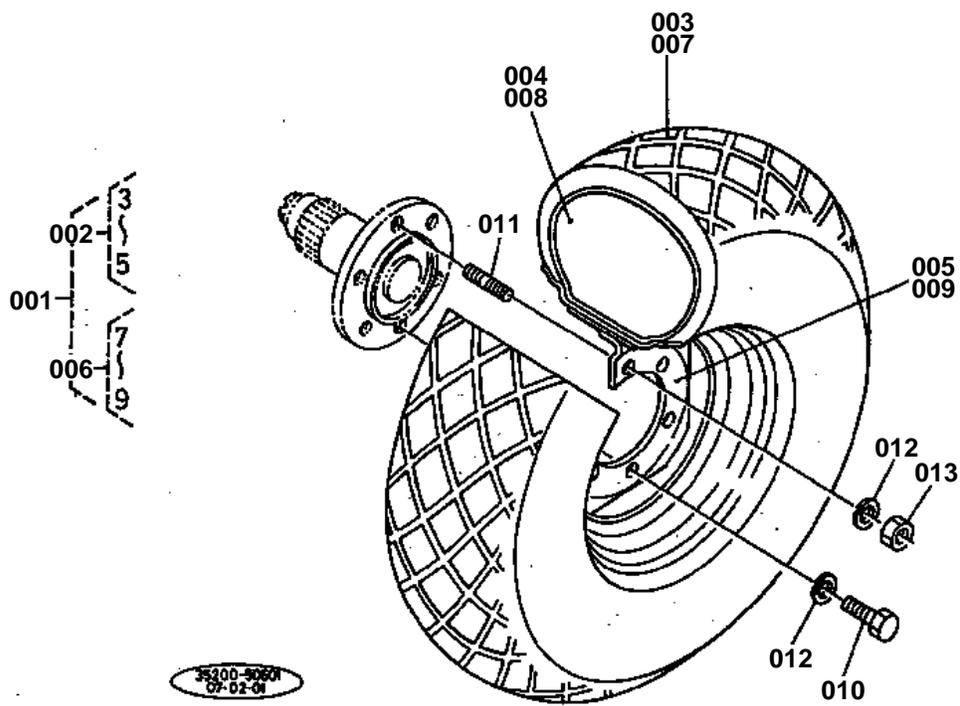



REAR WHEEL (13.6-16)

↔ Interchangeable; ≠ not interchangeable; ← new for old; → old for new

REF.No	Part No.	Description	Q'ty	S.No.	I/C	REMARKS	Weight (kgf)	Weight (lb)
001	35200-27602	ASSY REAR WHEEL	1				0	0
002	35200-27612	ASSY REAR WHEEL,LH	1				0	0
003	99424-27110	TIRE	1				30	66
004	99424-27120	TUBE	1				3.8	8.36
005	35200-27952	WHEEL	1				0	0
006	35200-27692	ASSY REAR WHEEL,RH	1				0	0
007	99424-27110	TIRE	1				30	66
008	99424-27120	TUBE	1				3.8	8.36
009	35200-27952	WHEEL	1				0	0
010	01073-51630	BOLT	8				0.079	0.1738
011	34150-27710	STUD	4				0.062	0.1364
012	04512-50160	WASHER,SPRING	16				0	0
013	02074-50160	NUT	4				0.029	0.0638

FRONT WHEEL HUB [2WD]

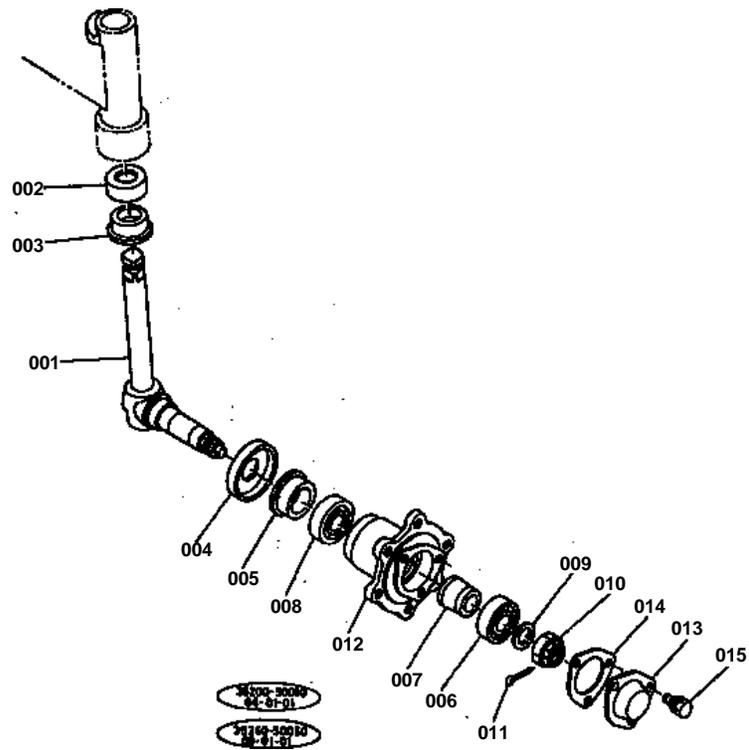



FRONT WHEEL HUB [2WD]

↔ Interchangeable; ≠ not interchangeable; ← new for old; → old for new

REF.No	Part No.	Description	Q'ty	S.No.	I/C	REMARKS	Weight (kgf)	Weight (lb)
001	34220-11110	ASSY KNUCKLE	2				2.5	5.5
002	32150-11510	BEARING,THRUST BALL	2				0.14	0.308
003	37300-11430	SEAL,OIL	2				0.05	0.11
004	32240-11480	COVER,DUST	2				0.08	0.176
005	37300-11160	SEAL,OIL	2				0.08	0.176
006	08101-06206	BEARING,BALL	2				0.196	0.4312
007	38240-11420	SPACER	2				0.205	0.451
008	08101-06205	BEARING,BALL	2				0.14	0.308
009	04011-50200	WASHER,PLAIN	2				0.015	0.033
010	02372-50200	NUT,SLOTTED	2				0.024	0.0528
011	05511-50435	PIN,SPLIT	2				0.004	0.0088
012	35260-11310	HUB,FRONT WHEEL	2				3.75	8.25
013	32240-11350	CAP,FRONT WHEEL	2				0.065	0.143
014	32150-11360	GASKET	2				0	0
015	01120-50816	BOLT	6				0	0

STEERING LINKAGE [2WD]

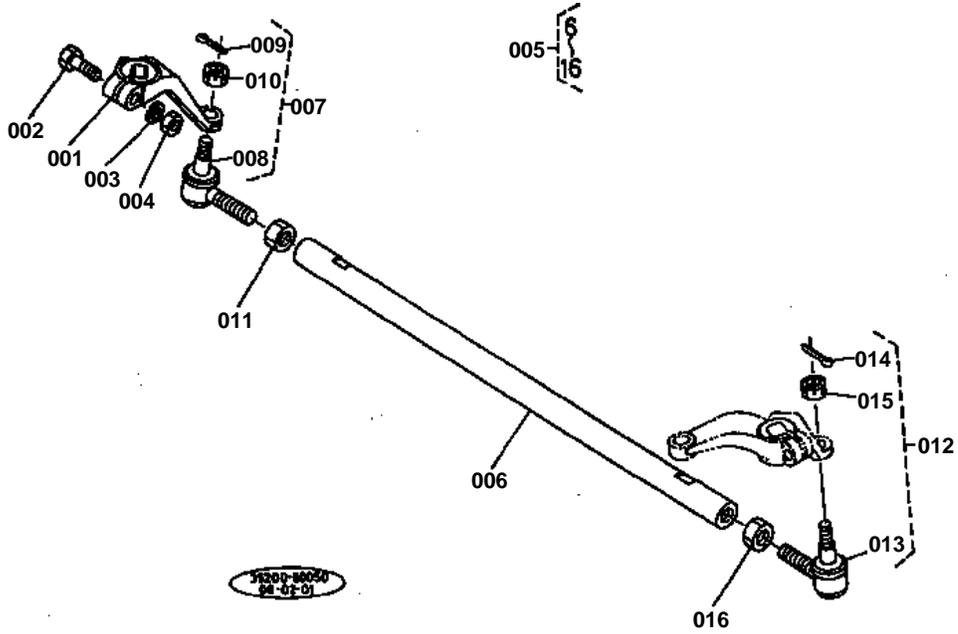

**STEERING LINKAGE [2WD]**

↔ Interchangeable; ≠ not interchangeable; ← new for old; → old for new

REF.No	Part No.	Description	Q'ty	S.No.	I/C	REMARKS	Weight (kgf)	Weight (lb)
001	34220-11210	ARM, KNUCKLE RH	1				1.3	2.86
002	32240-11270	BOLT	2				0.066	0.1452
003	04512-50120	WASHER, SPRING	2				0	0
004	02174-50120	NUT	2				0.01	0.022
005	35200-12400	ASSY ROD, TIE	1				2.55	5.61
006	35200-12410	ROD, TIE	1				1.9	4.18
007	38440-44780	ASSY END, TIE ROD RH	1				0.322	0.7084
008	99999-99999	BLANK	1			ORDER BY REF.No.007	0	0
009	05511-50325	PIN, SPLIT	1				0.002	0.0044
010	38240-12830	NUT, SLOTTED	1				0.008	0.0176
011	02172-50160	NUT	1				0.017	0.0374
012	38440-44790	ASSY END, TIE ROD LH	1				0.32	0.704
013	99999-99999	BLANK	1			ORDER BY REF.No.012	0	0
014	05511-50325	PIN, SLOTTED	1				0.002	0.0044
015	38240-12830	NUT, SLOTTED	1				0.008	0.0176
016	32240-12280	NUT	1				0.017	0.0374

FRONT AXLE [2WD]

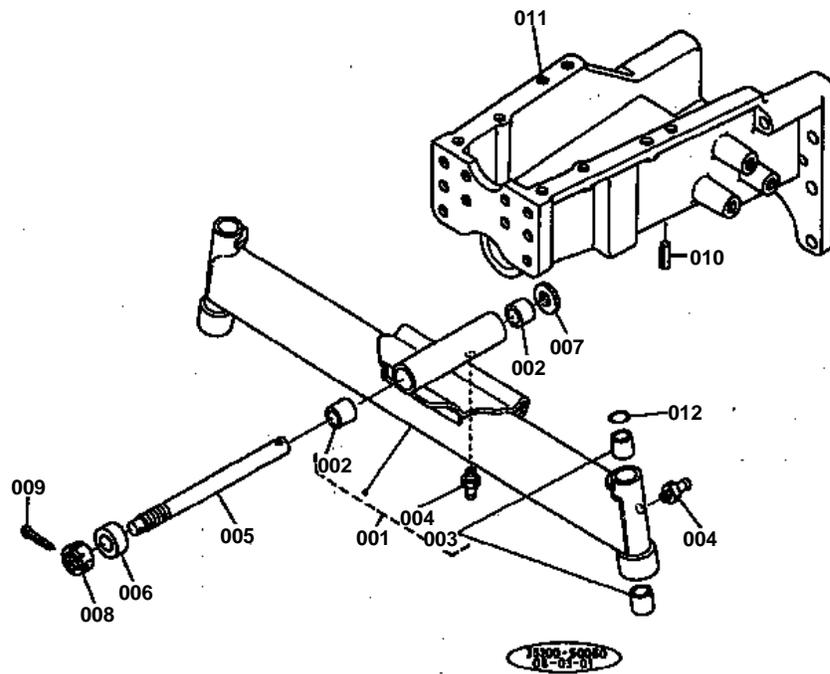

**FRONT AXLE [2WD]**

↔ Interchangeable; ≠ not interchangeable; ← new for old; → old for new

REF.No	Part No.	Description	Q'ty	S.No.	I/C	REMARKS	Weight (kgf)	Weight (lb)
001	35200-13110	FRONT AXLE	1				13.8	30.36
002	34150-13430	BUSH	2				0.027	0.0594
003	32150-11530	BUSH	4				0.063	0.1386
004	06613-10010	NIPPLE,GREASE	3				0.006	0.0132
005	37150-13410	PIN,CENTER	1				0.615	1.353
006	37150-13460	COLLAR,ADJUSTING	1				0.1	0.22
007	64135-35510	COLLAR	1				0.01	0.022
008	32210-13480	NUT,ADJUSTING	1				0.112	0.2464
009	05511-50430	PIN,SPLIT	1				0.004	0.0088
010	05411-00840	PIN,SPRING	1				0.008	0.0176
011	35170-13654	BRACKET,FRONT AXLE	1				16.9	37.18
012	04811-00280	O RING	2				0.002	0.0044

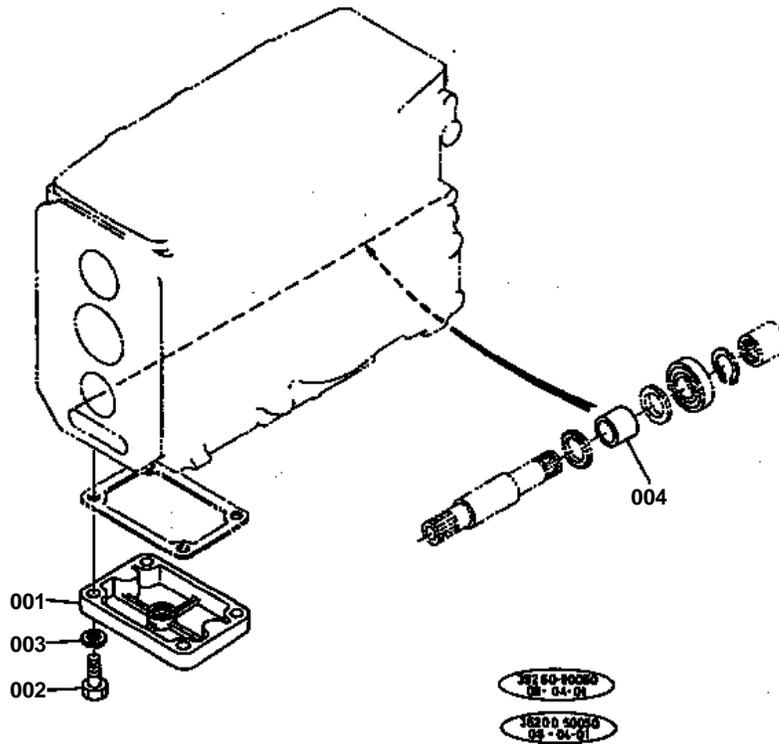

**MISSION COVER [2WD]**

↔ Interchangeable; ≠ not interchangeable; ← new for old; → old for new

REF.No	Part No.	Description	Q'ty	S.No.	I/C	REMARKS	Weight (kgf)	Weight (lb)
001	37150-21270	COVER	1				3.6	7.92
002	01173-51235	BOLT	4				0.04	0.088
003	04512-50120	WASHER,SPRING	4				0	0
004	38240-25360	COLLAR	1				0.12	0.264

DIFFERENTIAL CASE [4WD]

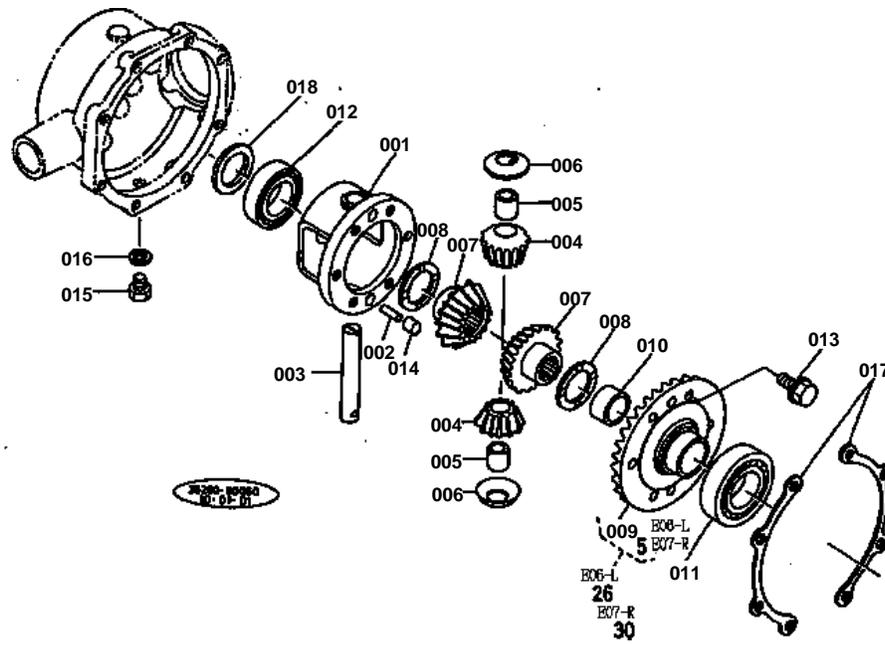

**DIFFERENTIAL CASE [4WD]**

↔ Interchangeable; ≠ not interchangeable; ← new for old; → old for new

REF.No	Part No.	Description	Q'ty	S.No.	I/C	REMARKS	Weight (kgf)	Weight (lb)
001	38440-43310	CASE, DIFFERENTIAL	1				2.1	4.62
002	37650-43320	PIN,SNAP	1				0.01	0.022
003	37650-43330	SHAFT,DIFF PINION	1				0.3	0.66
004	31220-26300	PINION, DIFFERENTIAL	2				0.155	0.341
005	31220-26360	BUSH	2				0.015	0.033
006	31220-26390	WASHER,DIFF PINION	2				0	0
007	38440-44980	GEAR,DIFF SIDE RH	2				0	0
008	31220-26480	WASHER	2				0.015	0.033
008	31220-26490	WASHER	2				0.02	0.044
008	37150-26480	WASHER	2				0.016	0.0352
009	99999-99999	BLANK	1			ORDER BY REF.No.026 ON FIG.No.093,REF.No	0	0
010	37650-43360	BUSH	1				0.039	0.0858
011	08101-06011	BEARING,BALL	1				0.376	0.8272
012	08101-06010	BEARING,BALL	1				0.262	0.5764
013	37800-43870	BOLT	6				0.026	0.0572
014	38440-43880	PIN,STRAIGHT	2				0	0
015	06331-35012	PLUG	1				0.022	0.0484
016	04717-01200	WASHER,SEAL	1				0.002	0.0044
017	37650-43130	SHIM 0.2	4				0.005	0.011
017	37650-43160	SHIM 0.1	4				0.002	0.0044
018	37650-43140	SHIM 0.2	2				0.005	0.011
018	37650-43170	SHIM 0.1	2				0.004	0.0088

BEVEL GEAR CASE [4WD]

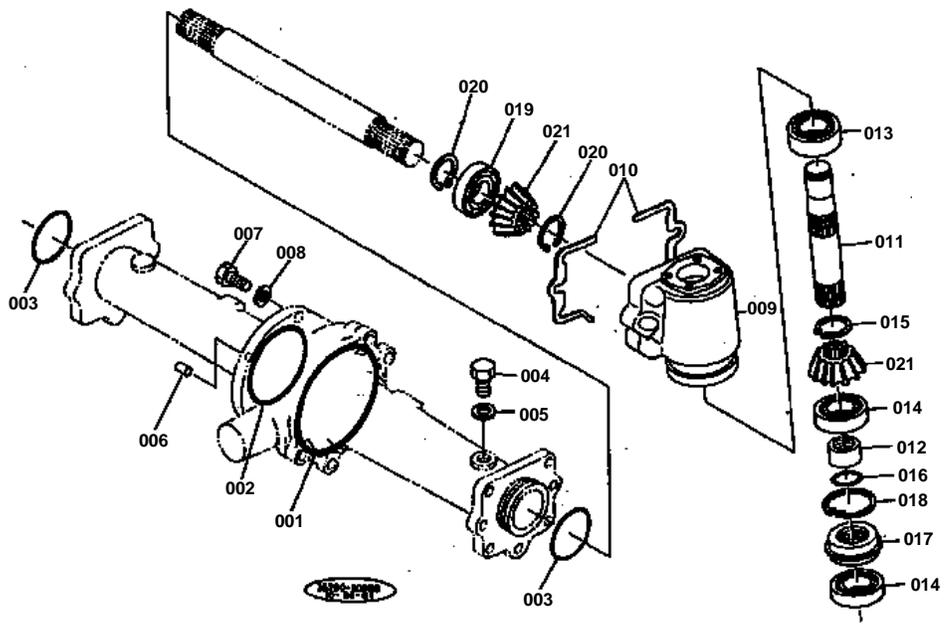

**BEVEL GEAR CASE [4WD]**

↔ Interchangeable; ≠ not interchangeable; ← new for old; → old for new

REF.No	Part No.	Description	Q'ty	S.No.	I/C	REMARKS	Weight (kgf)	Weight (lb)
001	34160-43440	O RING	1				0.005	0.011
002	04811-51300	O RING	1				0.004	0.0088
003	04811-50750	O RING	2				0.002	0.0044
004	06331-35020	PLUG	2				0.068	0.1496
005	04717-02000	WASHER,SEAL	2				0.004	0.0088
006	05012-01020	PIN,STRAIGHT	2				0.02	0.044
007	35250-43400	BOLT	8				0.025	0.055
008	04512-50100	WASHER,SPRING	8				0	0
009	38380-43440	CASE,BEVEL GEAR	2				2.9	6.38
010	37650-43450	SHIM 0.2	8				0.005	0.011
010	37650-43560	SHIM 0.1	8				0.005	0.011
011	38440-43460	SHAFT,BEVEL GEAR	2				1.1	2.42
012	38440-43480	COLLAR,SEAL	2				0.09	0.198
013	08101-06204	BEARING,BALL	2				0.102	0.2244
014	38450-25370	BEARING,BALL	4				0.2	0.44
015	04612-00300	CIR-CLIP,EXTERNAL	2				0.003	0.0066
016	04811-50300	O RING	2				0.001	0.0022
017	35290-43490	SEAL,OIL	2				0.09	0.198
018	04611-00620	CIR-CLIP,INTERNAL	2				0.011	0.0242
019	38450-25370	BEARING,BALL	2				0.2	0.44
020	04612-00300	CIR-CLIP,EXTERNAL	4				0.003	0.0066
021	37720-43820	GEAR,STR BEVEL 14	4				0.45	0.99

AXLE CASE [4WD]

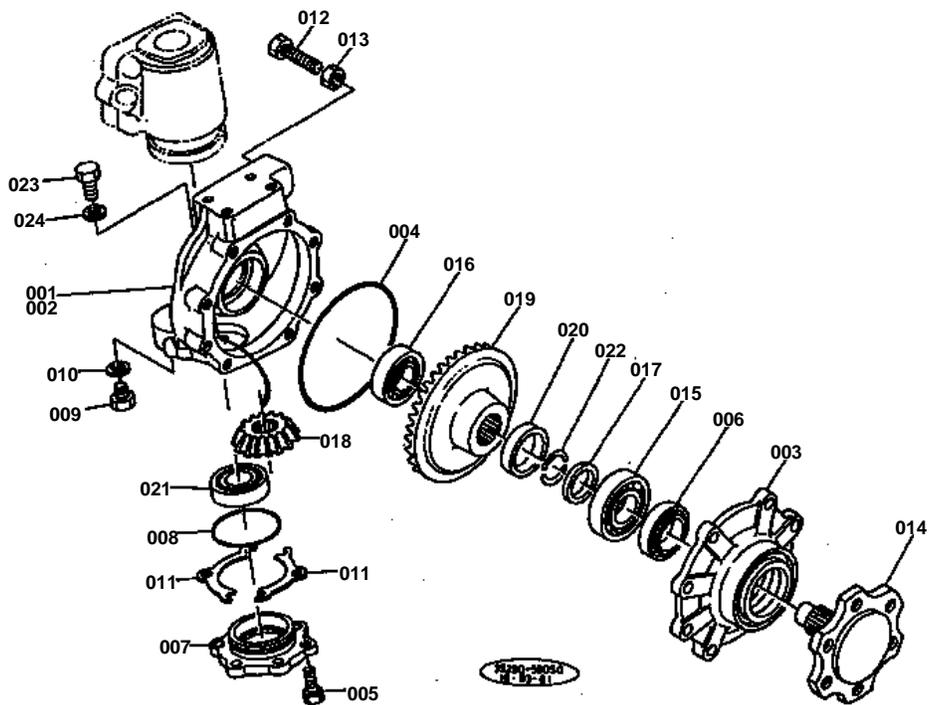

**AXLE CASE [4WD]**

↔ Interchangeable; ≠ not interchangeable; ← new for old; → old for new

REF.No	Part No.	Description	Q'ty	S.No.	I/C	REMARKS	Weight (kgf)	Weight (lb)
001	38380-43513	CASE,AXLE LH	1				7.2	15.84
002	38380-43543	CASE,AXLE RH	1				6	13.2
003	37720-43520	FLANGE,AXLE	2				2.5	5.5
004	37720-43550	O RING	2				0.01	0.022
005	01123-50822	BOLT	12				0.012	0.0264
006	37650-43530	SEAL,OIL	2				0.062	0.1364
007	37650-43580	CASE,BEARING	2				0.88	1.936
008	04811-50900	O RING	2				0.003	0.0066
009	06331-35012	PLUG	2				0.022	0.0484
010	04717-01200	WASHER,SEAL	2				0.002	0.0044
011	37650-43592	SHIM 0.2	16				0	0
011	37650-43570	SHIM 0.1	4				0.004	0.0088
012	01175-51450	BOLT	2				0.072	0.1584
013	02176-50140	NUT	2				0.014	0.0308
014	35290-43610	AXLE	2				3.7	8.14
015	08101-06207	BEARING,BALL	2				0.282	0.6204
016	08101-06206	BEARING,BALL	2				0.196	0.4312
017	37650-43670	COLLAR,THRUST	2				0.01	0.022
018	37720-43650	GEAR,STR BEVEL 17	2				0.5	1.1
019	37720-43660	GEAR,STR BEVEL 38	2				2.7	5.94
020	37720-43690	COLLAR	2				0.038	0.0836
021	08101-06008	BEARING,BALL	2				0.19	0.418
022	37650-43680	RING	4				0	0
023	06331-35020	PLUG	2				0.068	0.1496
024	04717-02000	WASHER,SEAL	2				0.004	0.0088

KNUCKLE ARM [4WD]

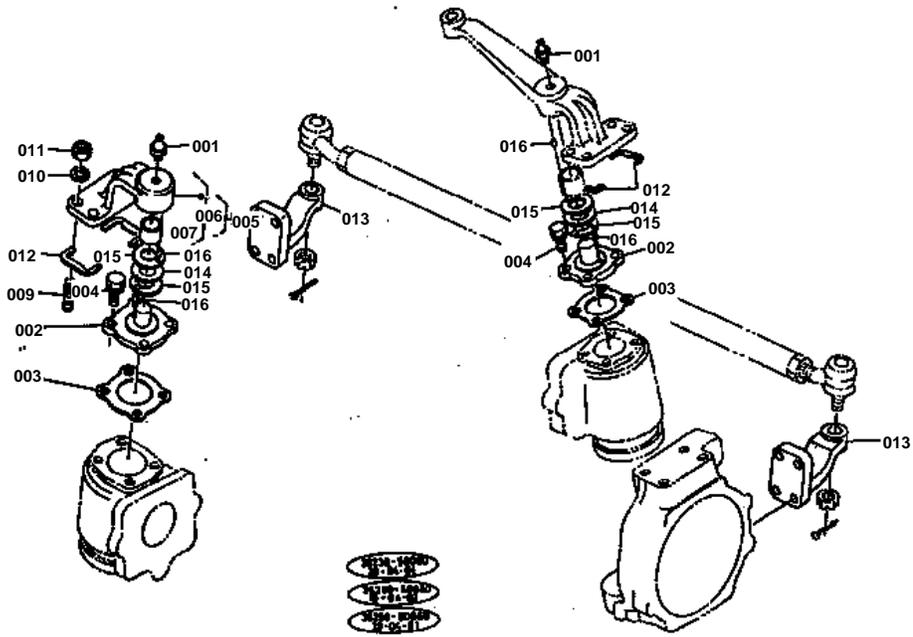

REF. No. ④ 64811-0280

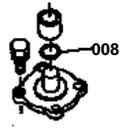

Continued

**KNUCKLE ARM [4WD]**

↔ Interchangeable; ≠ not interchangeable; ← new for old; → old for new

REF.No	Part No.	Description	Q'ty	S.No.	I/C	REMARKS	Weight (kgf)	Weight (lb)
001	04811-00260	O RING	1	>=10001			0.001	0.0022
001	06613-10010	NIPPLE,GREASE	2	>=10001			0.006	0.0132
002	38380-43920	PIN,KNUCKLE	1	<=10431			0.6	1.32
002	35290-43920	PIN,KNUCKLE	1	>=10432			0.65	1.43
003	38380-43980	GASKET	2				0.003	0.0066
004	01123-50822	BOLT	3				0.012	0.0264
005	38380-44060	ASSY SUPPORT,KNUCKLE	1	>=10001			1.145	2.519
005	35290-44060	ASSY SUPPORT,KNUCKLE	1	>=10001			0	0
006	38380-43900	SUPPORT,KNUCKLE RH	1	>=10001			1.17	2.574
006	35290-43900	SUPPORT,KNUCKLE RH	1	>=10001			1.29	2.838
007	37800-43890	BUSH	1	>=10001			0.035	0.077
007	35290-43890	BUSH	1	>=10001			0.03	0.066
008	04811-00260	O RING	1	<=10431			0.001	0.0022
009	01517-51028	STUD	4				0.022	0.0484
010	04512-50100	WASHER,SPRING	4				0	0
011	37300-14190	NUT	4				0.009	0.0198
012	37650-43860	SHIM 0.2	20				0.001	0.0022
013	38380-43940	ARM,KNUCKLE	2				0.765	1.683
014	35290-43870	WASHER	2	>=10432			0.17	0.374
015	35290-43880	WASHER	4	>=10432			0.03	0.066
016	05012-00408	PIN,SPLIT	4	>=10432			0.001	0.0022

DRIVE CASE [4WD]

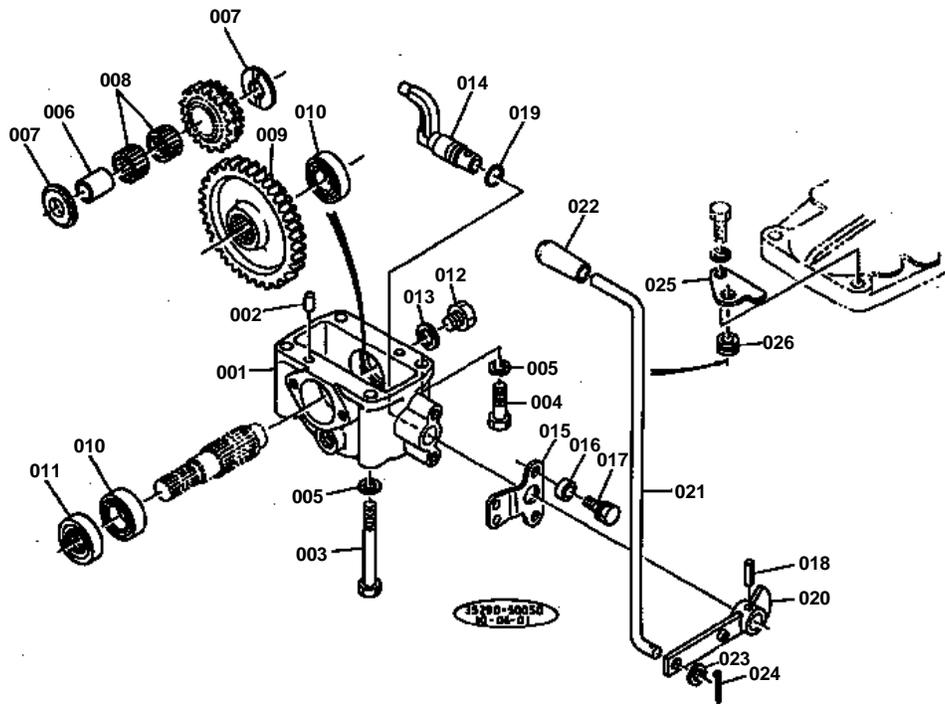

**DRIVE CASE [4WD]**

↔ Interchangeable; ≠ not interchangeable; ← new for old; → old for new

REF.No	Part No.	Description	Q'ty	S.No.	I/C	REMARKS	Weight (kgf)	Weight (lb)
001	38440-44210	CASE	1				1	2.2
002	05012-01018	PIN,STRAIGHT	2				0.012	0.0264
003	37720-44120	BOLT	2				0	0
004	01173-51235	BOLT	2				0.04	0.088
005	04512-50120	WASHER,SPRING	4				0	0
006	37650-44170	RACE,INNER	1				0.05	0.11
007	38240-21760	COLLAR,THRUST	2				0.02	0.044
008	08823-03614	BEARING,NEEDLE	2				0.022	0.0484
009	38440-44230	GEAR,45	1				1.3	2.86
010	08101-06205	BEARING,BALL	2				0.14	0.308
011	38440-44240	SEAL,OIL	1				0.027	0.0594
012	06331-35012	PLUG	1				0.022	0.0484
013	04717-01200	WASHER,SEAL	1				0.002	0.0044
014	38440-44310	LEVER,SHIFT	1				0.15	0.33
015	38440-44350	GUIDE,LEVER	1				0.055	0.121
016	35290-44390	COLLAR	2				0.015	0.033
017	01120-50825	BOLT	2				0	0
018	05411-00625	PIN,SPRING	1				0.004	0.0088
019	04811-00150	O RING	1				0.001	0.0022
020	35290-44360	LEVER,CHANGE	1				0.225	0.495
021	35290-44370	LEVER,CHANGE	1				0.495	1.089
022	06914-00120	GRIP,LEVER	1				0.018	0.0396
023	04011-50120	WASHER,PLAIN	1				0.005	0.011
024	05511-50425	PIN,SPLIT	1				0.003	0.0066
025	35290-44380	SUPPORT,LEVER	1				0.065	0.143
026	37800-44390	RUBBER,GUIDE	1				0.005	0.011

FRONT AXLE BRACKET [4WD]

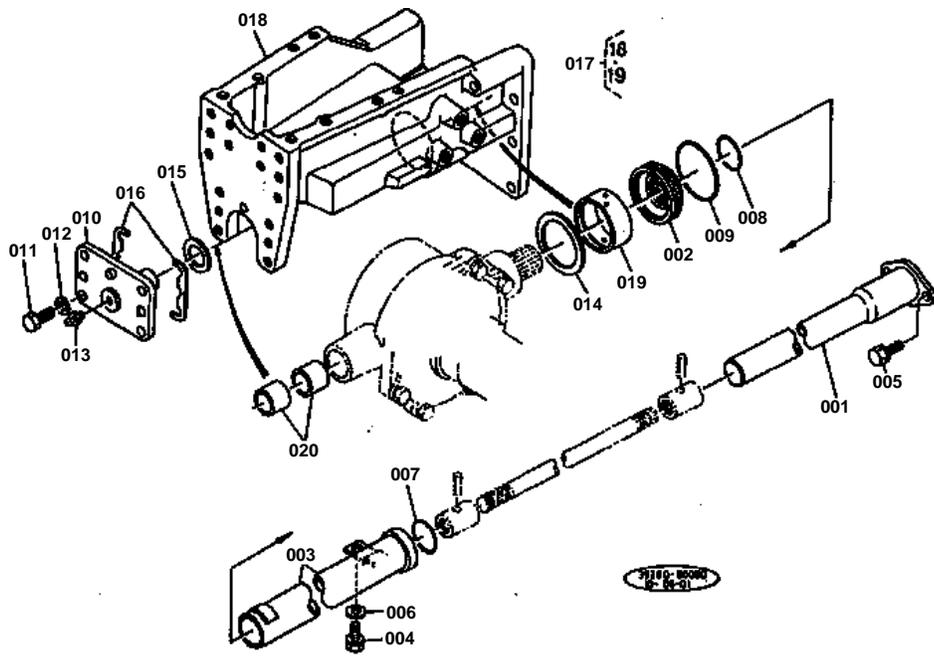



FRONT AXLE BRACKET [4WD]

↔ Interchangeable; ≠ not interchangeable; ← new for old; → old for new

REF.No	Part No.	Description	Q'ty	S.No.	I/C	REMARKS	Weight (kgf)	Weight (lb)
001	35290-44570	COVER 1	1				1.13	2.486
002	37650-44580	COVER,SEAL	1				0.22	0.484
003	35290-44590	COVER 2	1				0.54	1.188
004	01130-51020	BOLT	1				0	0
005	01120-50820	BOLT	2				0	0
006	04013-50100	WASHER,PLAIN	1				0	0
007	04811-00340	O RING	1				0.002	0.0044
008	04811-00380	O RING	1				0.003	0.0066
009	04811-50650	O RING	1				0.002	0.0044
010	37650-44610	PIN,CENTER	1				0.99	2.178
011	01173-51025	BOLT	6				0.021	0.0462
012	04512-50100	WASHER,SPRING	6				0	0
013	06613-10675	NIPPLE,GREASE	2				0.003	0.0066
014	37650-44640	COLLAR,THRUST	1				0.04	0.088
015	37650-44670	COLLAR,THRUST	1				0.03	0.066
016	37650-44650	SHIM 1	2				0.01	0.022
016	37650-44660	SHIM 0.2	20				0.001	0.0022
017	35250-44700	ASSY BRACKET,FRONT A	1				0	0
018	99999-99999	BLANK	1			ORDER BY REF.No.017	0	0
019	37650-44620	BUSH	1				0.09	0.198
020	37650-44630	BUSH	2				0.05	0.11

FRONT AXLE SUPPORT [4WD]

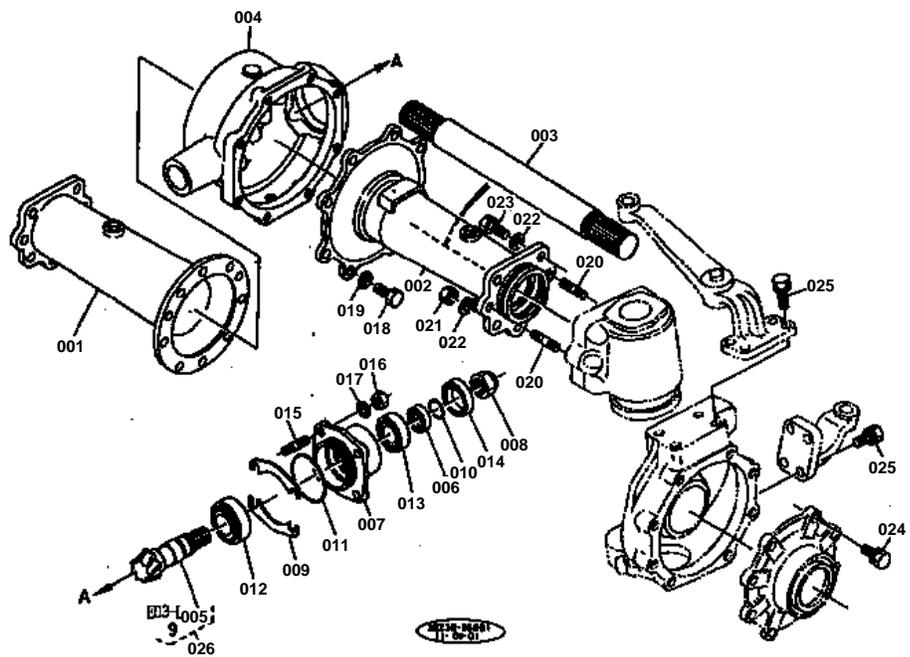



FRONT AXLE SUPPORT [4WD]

↔ Interchangeable; ≠ not interchangeable; ← new for old; → old for new

REF.No	Part No.	Description	Q'ty	S.No.	I/C	REMARKS	Weight (kgf)	Weight (lb)
001	35250-43410	SUPPORT,FRONT AXLE R	1				7.2	15.84
002	35250-43430	SUPPORT,FRONT AXLE L	1				9	19.8
003	35220-43810	SHAFT,DIFF YOKE	2				2.3	5.06
004	37650-43110	CASE,DIFF GEAR	1				6	13.2
005	99999-99999	BLANK	1			ORDER BY REF.No.026	0	0
006	37650-43220	COLLAR,OIL SEAL	1				0.05	0.11
007	37650-43230	CASE,PINION BEARING	1				0.87	1.914
008	31220-22340	NUT 22	1				0.033	0.0726
009	35290-43270	SHIM 0.2	6				0.01	0.022
009	35290-43280	SHIM 0.1	4				0.01	0.022
010	04811-00240	O RING	1				0.001	0.0022
011	04811-50700	O RING	1				0.002	0.0044
012	08711-30305	BEARING,TAPER ROLLER	1				0.266	0.5852
013	08711-30205	BEARING,TAPER ROLLER	1				0.148	0.3256
014	09500-35528	SEAL,OIL	1				0.017	0.0374
015	01513-50820	STUD	4				0	0
016	02156-50080	NUT	4				0.004	0.0088
017	04512-50080	WASHER,SPRING	4				0.001	0.0022
018	01173-51028	BOLT	8				0.022	0.0484
019	04512-50100	WASHER,SPRING	8				0	0
020	35230-43500	STUD	4				0.045	0.099
021	37800-43600	NUT	4				0.025	0.055
022	04512-50120	WASHER,SPRING	14				0	0
023	35250-43700	BOLT	10				0.045	0.099
024	01123-50822	BOLT	16				0.012	0.0264
025	01133-51025	BOLT	12				0.023	0.0506
026	35230-43300	ASSY BEVEL 7-34	1				3.1	6.82



STEERING LINKAGE [4WD]

↔ Interchangeable; ≠ not interchangeable; ← new for old; → old for new

REF.No	Part No.	Description	Q'ty	S.No.	I/C	REMARKS	Weight (kgf)	Weight (lb)
001	35230-43990	ASSY ROD,TIE	1				3.2	7.04
002	35230-43960	ROD,TIE	1				2.5	5.5
003	38440-44780	ASSY END,TIE ROD RH	1				0.322	0.7084
004	99999-99999	BLANK	1			ORDER BY REF.No.003	0	0
005	05511-50325	PIN,SPLIT	1				0.002	0.0044
006	38240-12830	NUT,SLOTTED	1				0.008	0.0176
007	38440-44790	ASSY END,TIE ROD LH	1				0.32	0.704
008	99999-99999	BLANK	1			ORDER BY REF.No.007	0	0
009	05511-50325	PIN,SPLIT	1				0.002	0.0044
010	38240-12830	NUT,SLOTTED	1				0.008	0.0176
011	02174-50160	NUT	1				0.022	0.0484
012	32240-12280	NUT	1				0.017	0.0374

PROPELLER SHAFT [4WD]

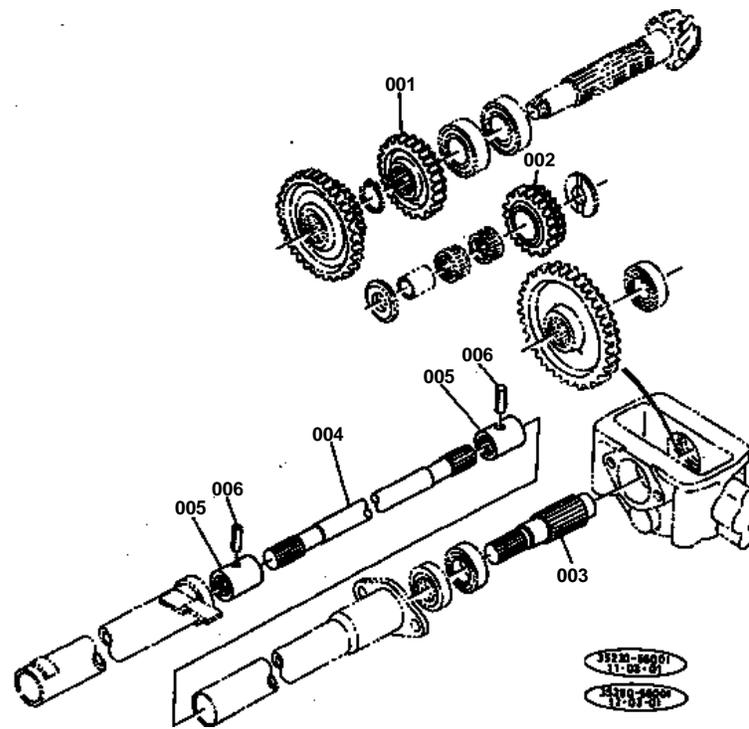



PROPELLER SHAFT [4WD]

↔ Interchangeable; ≠ not interchangeable; ← new for old; → old for new

REF.No	Part No.	Description	Q'ty	S.No.	I/C	REMARKS	Weight (kgf)	Weight (lb)
001	38420-44110	GEAR 31	1				0.535	1.177
002	38420-44122	GEAR 19-21	1				0	0
003	35230-44220	SHAFT,PTO	1				0.54	1.188
004	35230-44510	SHAFT,PROPELLER	1				2.6	5.72
005	35230-44520	COUPLING	2				0.17	0.374
006	05411-00425	PIN,SPRING	2				0.001	0.0022

POSITION CONTROL

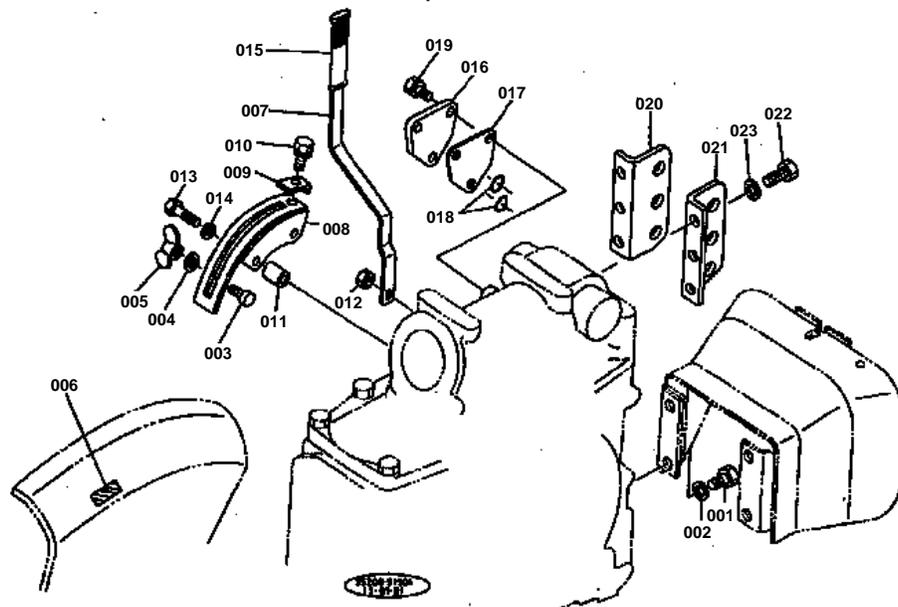



POSITION CONTROL

↔ Interchangeable; ≠ not interchangeable; ← new for old; → old for new

REF.No	Part No.	Description	Q'ty	S.No.	I/C	REMARKS	Weight (kgf)	Weight (lb)
001	01173-51225	BOLT	4				0.033	0.0726
002	04512-50120	WASHER,SPRING	4				0	0
003	32360-36870	STOPPER,LEVER	1				0.039	0.0858
004	04013-50100	WASHER,PLAIN	1				0	0
005	02870-50100	NUT,WING	1				0.015	0.033
006	35176-36980	LABEL,CONTROL	1				0.001	0.0022
007	35200-36852	LEVER,CONTROL	1				0	0
008	37150-36860	GUIDE,LEVER	1				0.285	0.627
009	37150-36910	STOPPER	1				0.02	0.044
010	01120-50816	BOLT	1				0	0
011	37150-36870	COLLAR	2				0.02	0.044
012	38240-36860	NUT	1				0.015	0.033
013	01150-50845	BOLT	2				0.019	0.0418
014	04512-50080	WASHER,SPRING	2				0.001	0.0022
015	37150-36890	GRIP,LEVER	1				0.035	0.077
016	34260-37150	COVER	1				0.155	0.341
017	34260-37160	PLATE	1				0.04	0.088
018	04810-00160	O RING	2				0.001	0.0022
019	01123-50820	BOLT	3				0.011	0.0242
020	99571-22140	HOLDER, TOP LINK RH	1				0.99	2.178
021	99571-22150	HOLDER, TOP LINK LH	1				0.99	2.178
022	01173-51230	BOLT	6				0.037	0.0814
023	04512-50120	WASHER,SPRING	6				0	0

DRAFT CONTROL

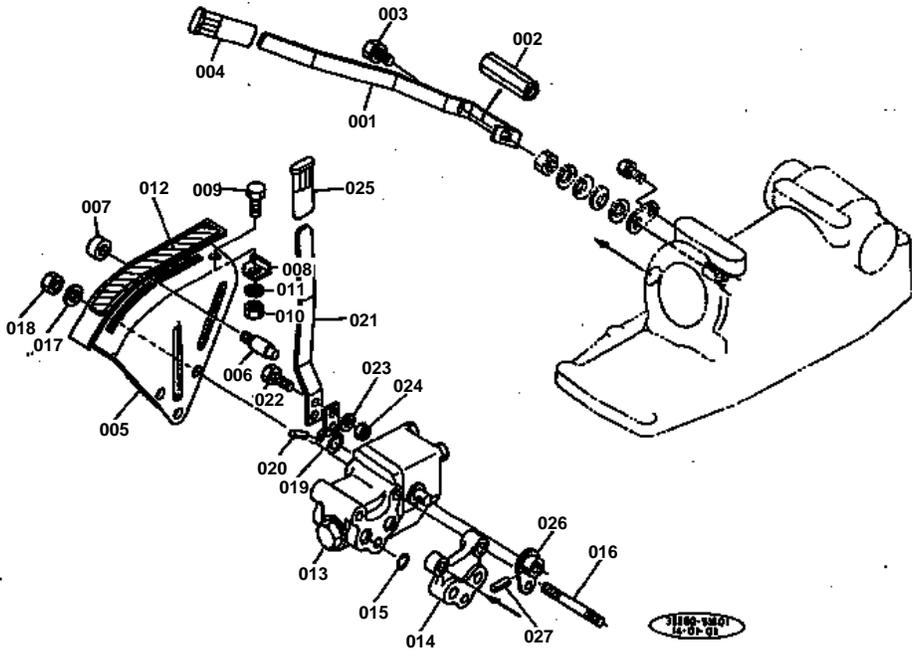



DRAFT CONTROL

↔ Interchangeable; ≠ not interchangeable; ← new for old; → old for new

REF.No	Part No.	Description	Q'ty	S.No.	I/C	REMARKS	Weight (kgf)	Weight (lb)
001	35260-36850	LEVER,CONTROL	1				0.315	0.693
002	35260-36840	SUPPORT,LEVER	1				0.16	0.352
003	01120-50814	BOLT	1				0	0
004	34350-36890	GRIP,LEVER	1				0.016	0.0352
005	35112-36860	GUIDE,O/P LEVER	1				1.02	2.244
006	37300-36910	STOPPER	1				0.05	0.11
007	37300-36920	NUT	1				0.046	0.1012
008	37300-36930	STOPPER	1				0.02	0.044
009	01170-51016	BOLT	1				0.016	0.0352
010	02118-50100	NUT	1				0.005	0.011
011	04512-50100	WASHER,SPRING	1				0	0
012	35212-36980	LABEL,CONTROL	1				0.005	0.011
013	37300-41100	ASSY VALVE,DRAFT CON	1				3.2	7.04
014	37300-41210	SPACER	1				0	0
015	04810-00160	O RING	2				0.001	0.0022
016	37300-41250	STUD	3				0.04	0.088
017	04512-50080	WASHER,SPRING	3				0.001	0.0022
018	02156-50080	NUT	3				0.004	0.0088
019	37300-41220	LEVER,DRAFT CONTROL	1				0.042	0.0924
020	05411-00525	PIN,SPRING	1				0.002	0.0044
021	35260-41230	LEVER,DRAFT CONTROL	1				0.15	0.33
022	01053-50616	BOLT	2				0.005	0.011
023	04512-50060	WASHER,SPRING	2				0	0
024	02056-50060	NUT	2				0.002	0.0044
025	34350-36890	GRIP,LEVER	1				0.016	0.0352
026	35212-41190	LEVER,FEEDBACK	1				0.052	0.1144
027	05411-00525	PIN,SPRING	1				0.002	0.0044

DRAFT CONTROL VALVE SECTION PARTS

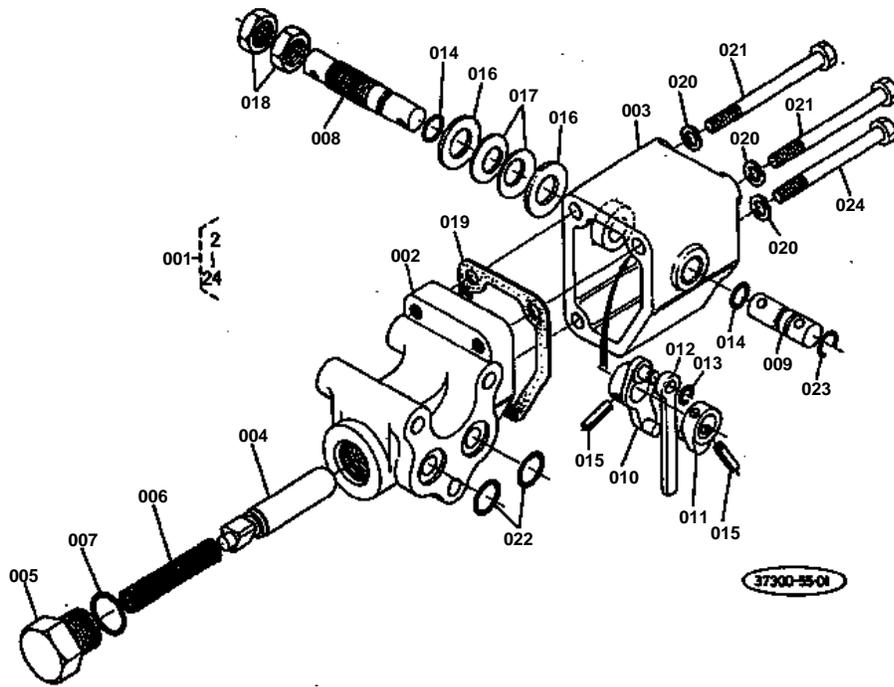



DRAFT CONTROL VALVE SECTION PARTS

↔ Interchangeable; ≠ not interchangeable; ← new for old; → old for new

REF.No	Part No.	Description	Q'ty	S.No.	I/C	REMARKS	Weight (kgf)	Weight (lb)
001	37300-41100	ASSY VALVE,DRAFT CON	1				3.2	7.04
002	99999-99999	BLANK	1			ORDER BY REF.No.001	0	0
003	37300-41120	COVER	1				1.05	2.31
004	99999-99999	BLANK	1			ORDER BY REF.No.001	0	0
005	37300-41140	PLUG	1				0.098	0.2156
006	37300-41150	SPRING	1				0.01	0.022
007	04811-00180	O RING	1				0.001	0.0022
008	37300-41160	SHAFT	1				0.065	0.143
009	37300-41170	SHAFT	1				0.03	0.066
010	37300-41180	ARM	1				0.03	0.066
011	32240-36630	ARM	1				0.015	0.033
012	37300-41270	LINK	1				0.012	0.0264
013	04613-00050	CIR-CLIP,EXTERNAL	1				0	0
014	04811-00090	O RING	2				0.001	0.0022
015	05411-00518	PIN,SPRING	2				0.002	0.0044
016	04011-50140	WASHER,PLAIN	2				0.007	0.0154
017	37300-41280	SPRING	2				0.005	0.011
018	02172-50140	NUT	2				0.01	0.022
019	37300-41290	GASKET	1				0.001	0.0022
020	04512-50080	WASHER,SPRING	3				0.001	0.0022
021	01150-50875	BOLT	2				0	0
022	04810-00160	O RING	2				0.001	0.0022
023	37300-41360	RING	1				0.001	0.0022
024	01150-50870	BOLT	1				0	0

TOP LINK HOLDER

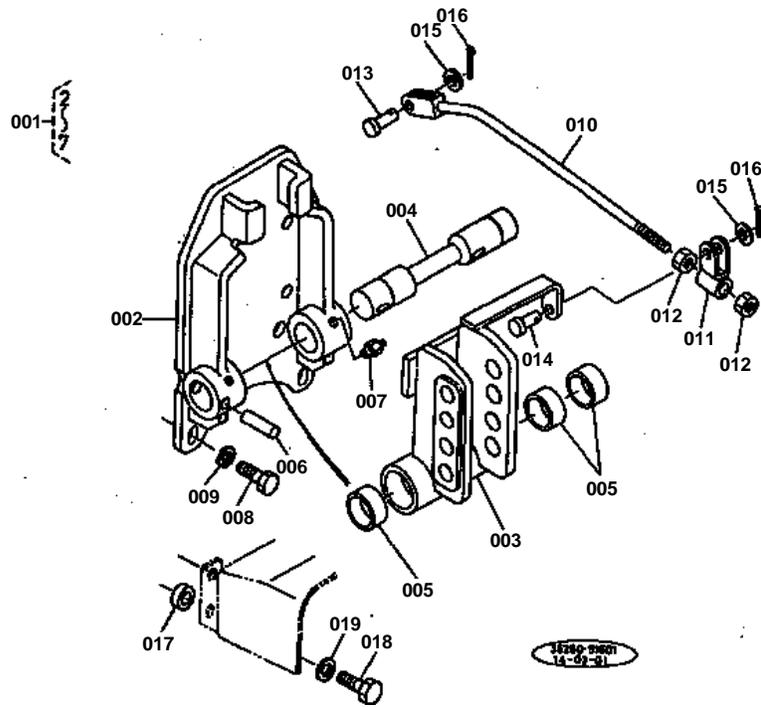



TOP LINK HOLDER

↔ Interchangeable; ≠ not interchangeable; ← new for old; → old for new

REF.No	Part No.	Description	Q'ty	S.No.	I/C	REMARKS	Weight (kgf)	Weight (lb)
001	35212-41400	ASSY HOLDER, TOP LINK	1				6.8	14.96
002	99999-99999	BLANK	1			ORDER BY REF.No.001	0	0
003	99999-99999	BLANK	1			ORDER BY REF.No.001	0	0
004	99999-99999	BLANK	1			ORDER BY REF.No.001	0	0
005	37300-41450	BUSH	3				0.03	0.066
006	37300-41440	PIN, STRAIGHT	2				0.055	0.121
007	06613-10010	NIPPLE, GREASE	3				0.006	0.0132
008	01173-51230	BOLT	4				0.037	0.0814
009	04512-50120	WASHER, SPRING	4				0	0
010	35260-41310	ROD, DRAFT CONTROL	1				0.105	0.231
011	35260-41320	ROD, DRAFT CONTROL	1				0.03	0.066
012	02112-50080	NUT	2				0.003	0.0066
013	05122-50814	PIN, JOINT	1				0.005	0.011
014	05122-50818	PIN, JOINT	1				0.008	0.0176
015	04012-50080	WASHER, PLAIN	2				0.001	0.0022
016	05511-50218	PIN, SPLIT	2				0.001	0.0022
017	35114-25340	COLLAR	2				0.02	0.044
018	01173-51235	BOLT	4				0.04	0.088
019	04512-50120	WASHER, SPRING	4				0	0

STEERING [2WD]

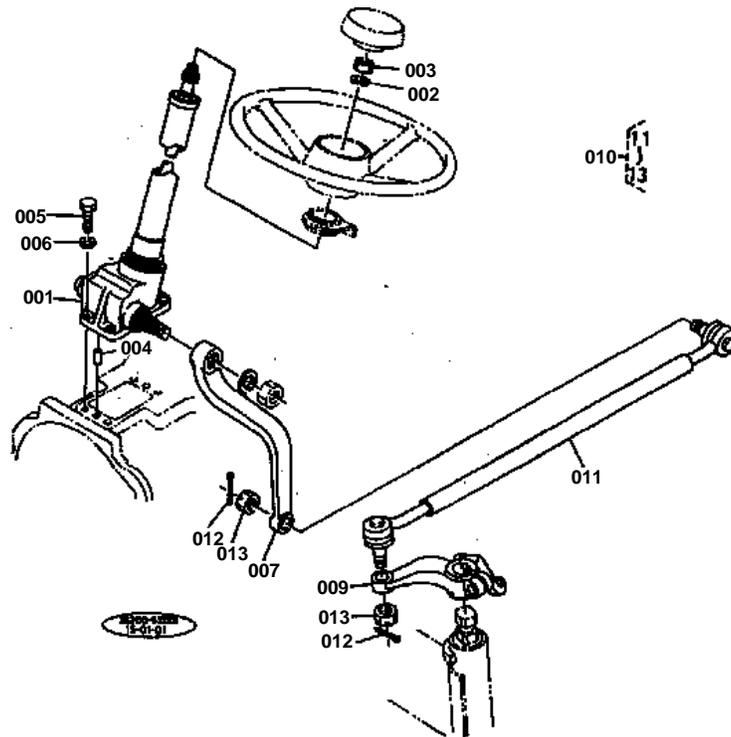

**STEERING [2WD]**

↔ Interchangeable; ≠ not interchangeable; ← new for old; → old for new

REF.No	Part No.	Description	Q'ty	S.No.	I/C	REMARKS	Weight (kgf)	Weight (lb)
001	35200-16100	ASSY STEERING	1				6.4	14.08
002	04512-50120	WASHER,SPRING	1				0	0
003	02174-50120	NUT	1				0.01	0.022
004	37150-27370	PIN,STRAIGHT	2				0.009	0.0198
005	01173-51025	BOLT	4				0.021	0.0462
006	04512-50100	WASHER,SPRING	4				0	0
007	35260-43930	ARM,PITMAN	1				1.19	2.618
008	99999-99999	BLANK	0				0	0
009	34220-11220	ARM,KNUCKLE LH	1				1.9	4.18
010	35200-12200	ASSY LINK,DRAG	1				2.5	5.5
011	99999-99999	BLANK	1			ORDER BY REF.No.010	0	0
012	05511-50325	PIN,SPLIT	2				0.002	0.0044
013	38240-12830	NUT,SLOTTED	2				0.008	0.0176

STEERING SECTION PARTS [2WD]

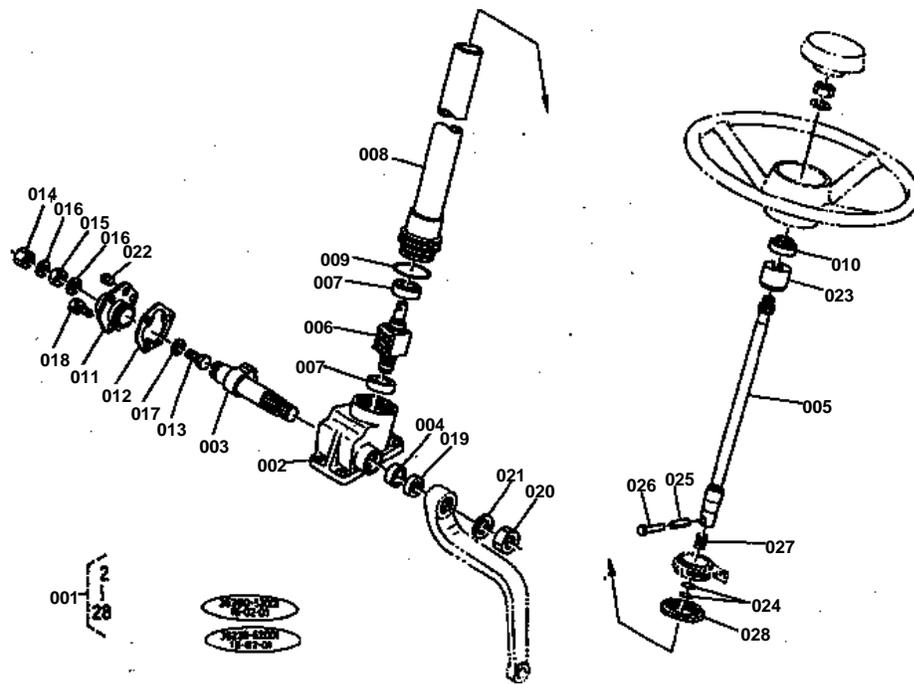



STEERING SECTION PARTS [2WD]

↔ Interchangeable; ≠ not interchangeable; ← new for old; → old for new

REF.No	Part No.	Description	Q'ty	S.No.	I/C	REMARKS	Weight (kgf)	Weight (lb)
001	35200-16102	ASSY STEERING	1				0	0
002	35200-16110	BOX,GEAR	1				2.6	5.72
003	38180-16120	SHAFT,SECTOR	1				0.068	0.1496
004	99999-99999	BLANK	1			ORDER BY REF.No.001	0	0
005	99999-99999	BLANK	1			ORDER BY REF.No.001	0	0
006	38180-16200	ASSY BALL NUT	1				1.375	3.025
007	38260-16220	BEARING,BALL	2				0.05	0.11
008	38240-16300	ASSY COLUMN	1				1.21	2.662
009	38240-16320	O RING	1				0.002	0.0044
010	38240-16390	SEAL,OIL	1				0.03	0.066
011	38180-16410	COVER,SIDE	1				0.365	0.803
012	38180-16420	GASKET	1				0.002	0.0044
013	32130-16480	SCREW,ADJUSTING	1				0.025	0.055
014	37300-16580	NUT,CAP	1				0.01	0.022
015	02116-50100	NUT	1				0.004	0.0088
016	04714-00100	GASKET	2				0.002	0.0044
017	34150-16440	COLLAR,ADJUSTING 1	1				0.002	0.0044
017	34150-16450	COLLAR,ADJUSTING 2	1				0.002	0.0044
017	34150-16460	COLLAR,ADJUSTING 3	1				0.002	0.0044
017	34150-16470	COLLAR,ADJUSTING 4	1				0.002	0.0044
017	34150-16480	COLLAR,ADJUSTING 5	1				0.002	0.0044
018	01123-50822	BOLT	3				0.012	0.0264
019	09500-26387	SEAL,OIL	1				0.008	0.0176
020	02172-50200	NUT	1				0.03	0.066
021	04512-50200	WASHER,SPRING	1				0	0
022	34150-16640	PLUG	1				0.015	0.033
023	38240-16520	BUSH	1				0.04	0.088
024	99999-99999	BLANK	2			ORDER BY REF.No.001	0	0
025	99999-99999	BLANK	1			ORDER BY REF.No.001	0	0
026	99999-99999	BLANK	1			ORDER BY REF.No.001	0	0
027	99999-99999	BLANK	1			ORDER BY REF.No.001	0	0
028	38240-16630	NUT	1				0.035	0.077

RELIEF VALVE [2WD]

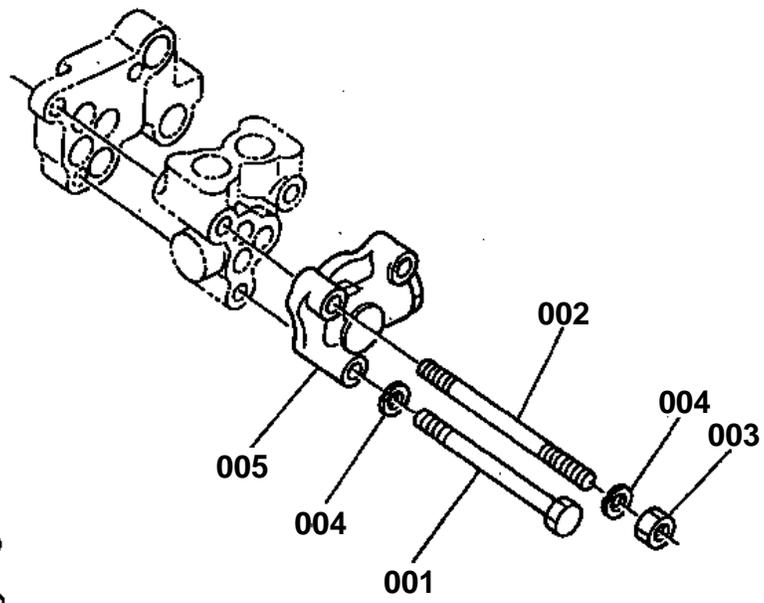

- 35200-52001
15-03-01
- 35230-52001
16-03-01
- 35260-52001
17-03-01
- 35290-52001
18-03-01

**RELIEF VALVE [2WD]**

↔ Interchangeable; ≠ not interchangeable; ← new for old; → old for new

REF.No	Part No.	Description	Q'ty	S.No.	I/C	REMARKS	Weight (kgf)	Weight (lb)
001	01153-50895	BOLT	2				0.035	0.077
002	37300-41250	STUD	1				0.04	0.088
003	02114-50080	NUT	1				0.005	0.011
004	04512-50080	WASHER,SPRING	3				0.001	0.0022
005	35260-39570	ASSY VALVE,RELIEF	1				0.88	1.936

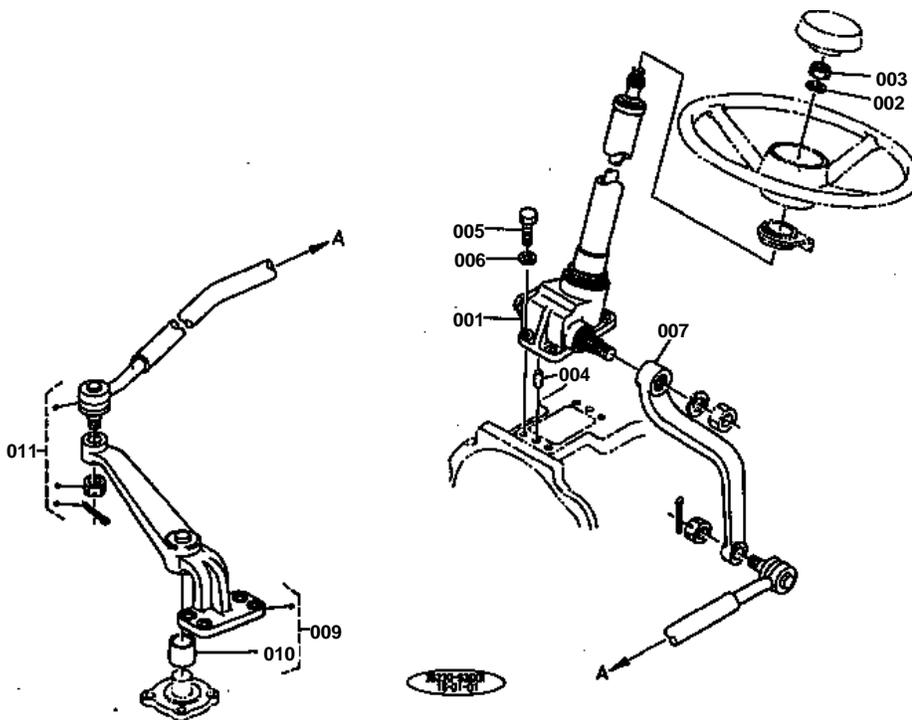

**STEERING [4WD]**

↔ Interchangeable; ≠ not interchangeable; ← new for old; → old for new

REF.No	Part No.	Description	Q'ty	S.No.	I/C	REMARKS	Weight (kgf)	Weight (lb)
001	35200-16100	ASSY STEERING	1				6.4	14.08
002	04512-50120	WASHER,SPRING	1				0	0
003	02174-50120	NUT	1				0.01	0.022
004	37150-27370	PIN,STRAIGHT	2				0.009	0.0198
005	01173-51025	BOLT	4				0.021	0.0462
006	04512-50100	WASHER,SPRING	4				0	0
007	35260-43930	ARM,PITMAN	1				1.19	2.618
008	99999-99999	BLANK	0				0	0
009	38380-44050	END,DRAG LINK	1	<=10431			0	0
009	35230-43910	END,DRAG LINK	1	>=10432			2.35	5.17
010	37800-43890	BUSH	1	<=10431			0.035	0.077
010	35290-43890	BUSH	1	>=10432			0.03	0.066
011	35290-43970	LINK,DRAG	1	<=10431			2.4	5.28
011	35230-43970	LINK,DRAG	1	>=10432			2.8	6.16

STEERING SECTION PARTS [4WD]

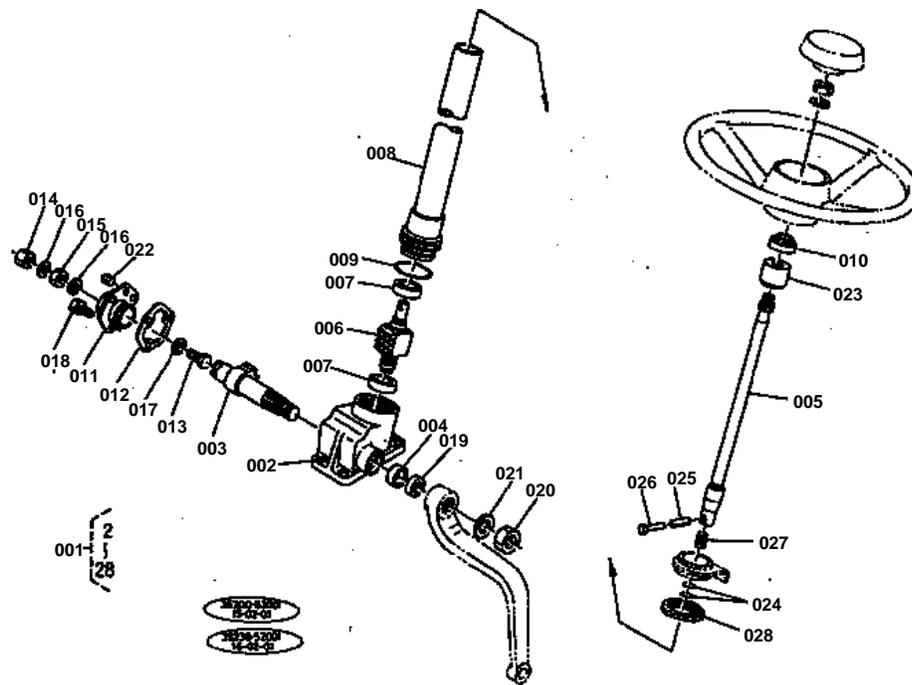



STEERING SECTION PARTS [4WD]

↔ Interchangeable; ≠ not interchangeable; ← new for old; → old for new

REF.No	Part No.	Description	Q'ty	S.No.	I/C	REMARKS	Weight (kgf)	Weight (lb)
001	35200-16100	ASSY STEERING	1				6.4	14.08
002	35200-16110	CASE,GEAR	1				2.6	5.72
003	38180-16120	SHAFT,SECTOR	1				0.068	0.1496
004	99999-99999	BLANK	1			ORDER BY REF.No.001	0	0
005	99999-99999	BLANK	1			ORDER BY REF.No.001	0	0
006	38180-16200	ASSY BALL NUT	1				1.375	3.025
007	38260-16220	BEARING,BALL	2				0.05	0.11
008	38240-16300	ASSY COLUMN	1				1.21	2.662
009	38240-16320	O RING	1				0.002	0.0044
010	38240-16390	SEAL,OIL	1				0.03	0.066
011	38180-16410	COVER,SIDE	1				0.365	0.803
012	38180-16420	GASKET	1				0.002	0.0044
013	32130-16480	SCREW,ADJUSTING	1				0.025	0.055
014	37300-16580	NUT,CAP	1				0.01	0.022
015	02116-50100	NUT	1				0.004	0.0088
016	04714-00100	GASKET	2				0.002	0.0044
017	34150-16440	COLLAR,ADJUSTING	1				0.002	0.0044
017	34150-16450	COLLAR,ADJUSTING 2	1				0.002	0.0044
017	34150-16460	COLLAR,ADJUSTING 3	1				0.002	0.0044
017	34150-16470	COLLAR,ADJUSTING 4	1				0.002	0.0044
017	34150-16480	COLLAR,ADJUSTING 5	1				0.002	0.0044
018	01123-50822	BOLT	3				0.012	0.0264
019	09500-26387	SEAL,OIL	1				0.008	0.0176
020	02172-50200	NUT	1				0.03	0.066
021	04512-50200	WASHER,SPRING	1				0	0
022	34150-16640	PLUG	1				0.015	0.033
023	38240-16520	BUSH	1				0.04	0.088
024	99999-99999	BLANK	2			ORDER BY REF.No.001	0	0
025	99999-99999	BLANK	1			ORDER BY REF.No.001	0	0
026	99999-99999	BLANK	1			ORDER BY REF.No.001	0	0
027	99999-99999	BLANK	1			ORDER BY REF.No.001	0	0
028	38240-16630	NUT	1				0.035	0.077

RELIEF VALVE [4WD]

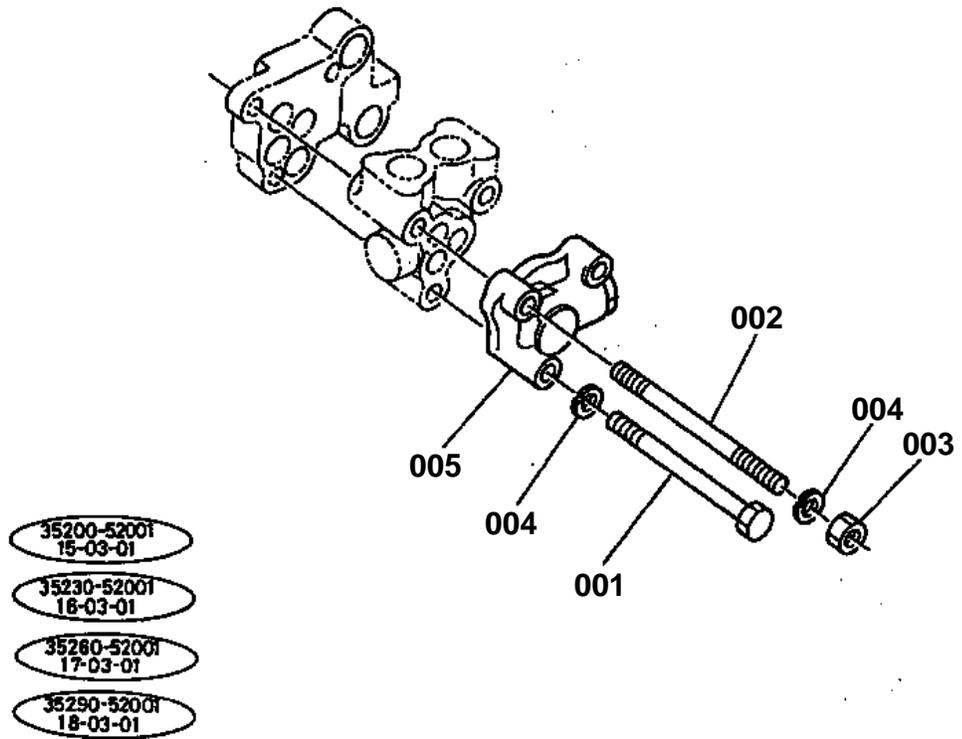

**RELIEF VALVE [4WD]**

↔ Interchangeable; ≠ not interchangeable; ← new for old; → old for new

REF.No	Part No.	Description	Q'ty	S.No.	I/C	REMARKS	Weight (kgf)	Weight (lb)
001	01153-50895	BOLT	2				0.035	0.077
002	37300-41250	STUD	1				0.04	0.088
003	02114-50080	NUT	1				0.005	0.011
004	04512-50080	WASHER,SPRING	3				0.001	0.0022
005	35260-39570	ASSY VALVE,RELIEF	1				0.88	1.936

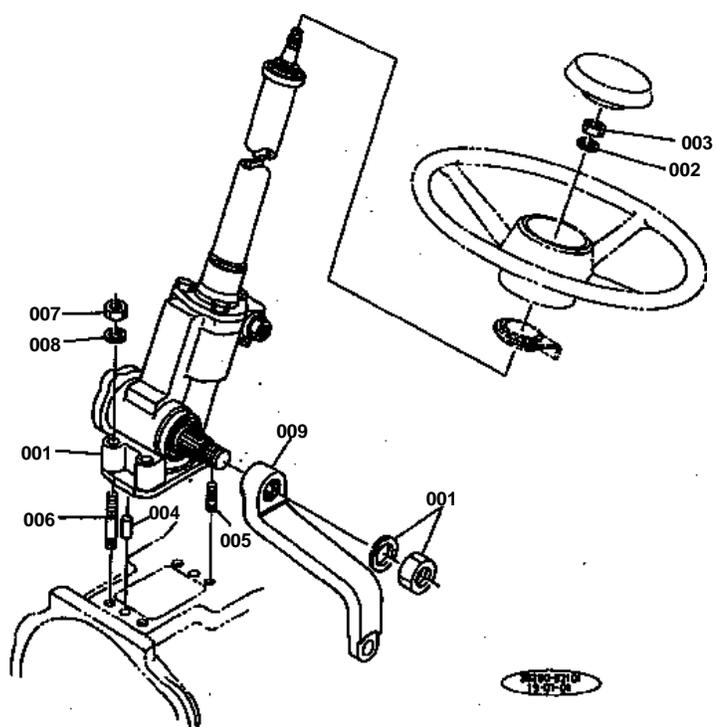

**POWER STEERING [4WD]**

↔ Interchangeable; ≠ not interchangeable; ← new for old; → old for new

REF.No	Part No.	Description	Q'ty	S.No.	I/C	REMARKS	Weight (kgf)	Weight (lb)
001	35270-16100	ASSY POWER STEERING	1	<=10431			14.5	31.9
001	35270-16105	ASSY POWER STEERING	1	>=10432			0	0
002	04512-50120	WASHER,SPRING	1				0	0
003	02174-50120	NUT	1				0.01	0.022
004	37150-27370	PIN,STRAIGHT	2				0.009	0.0198
005	01517-51030	STUD	2				0	0
006	01517-51090	STUD	2				0	0
007	37300-14190	NUT	4				0.009	0.0198
008	04512-50100	WASHER,SPRING	4				0	0
009	35270-16910	ARM,PITMAN	1				2.1	4.62

FLOW PRIORITY VALVE [4WD]

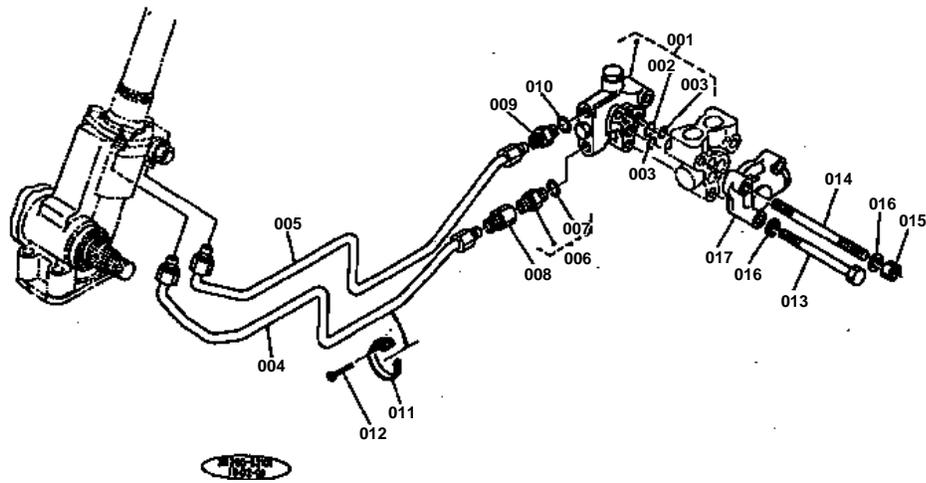



FLOW PRIORITY VALVE [4WD]

↔ Interchangeable; ≠ not interchangeable; ← new for old; → old for new

REF.No	Part No.	Description	Q'ty	S.No.	I/C	REMARKS	Weight (kgf)	Weight (lb)
001	35270-16710	ASSY VALVE,FLOW PRIO	1				1.7	3.74
002	04810-00160	O RING	1				0.001	0.0022
003	04810-00120	O RING	2				0.001	0.0022
004	35260-16720	ASSY PIPE 1	1				0.24	0.528
005	35260-16760	ASSY PIPE 2	1				0.23	0.506
006	35330-16770	ASSY CONNECTOR	1				0.065	0.143
007	04810-00140	O RING	1				0.001	0.0022
008	35330-16790	NIPPLE	1				0.05	0.11
009	35270-16790	PIPE JOINT	1				0.05	0.11
010	04810-00140	O RING	2				0.001	0.0022
011	67111-53770	BAND,PIPE	1				0.01	0.022
012	33430-82760	PIN,PIPE BAND	1				0.004	0.0088
013	35260-41240	BOLT	1				0.06	0.132
014	35260-41250	STUD	2				0.06	0.132
015	02156-50080	NUT	2				0.004	0.0088
016	04512-50080	WASHER,SPRING	3				0.001	0.0022
017	38240-36600	ASSY VALVE,RELIEF	1				0.885	1.947

DRAG LINK [2WD]

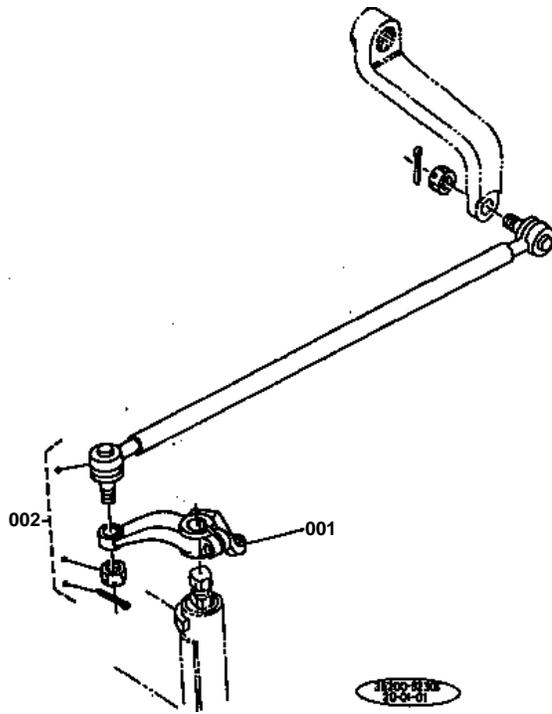



DRAG LINK [2WD]

↔ Interchangeable; ≠ not interchangeable; ← new for old; → old for new

REF.No	Part No.	Description	Q'ty	S.No.	I/C	REMARKS	Weight (kgf)	Weight (lb)
001	35270-11220	ARM, KNUCKLE LH	1				1.8	3.96
002	99999-99999	BLANK	1			ORDER BY REF.No.001 ON FIG.No.103	0	0

DRAG LINK [4WD]

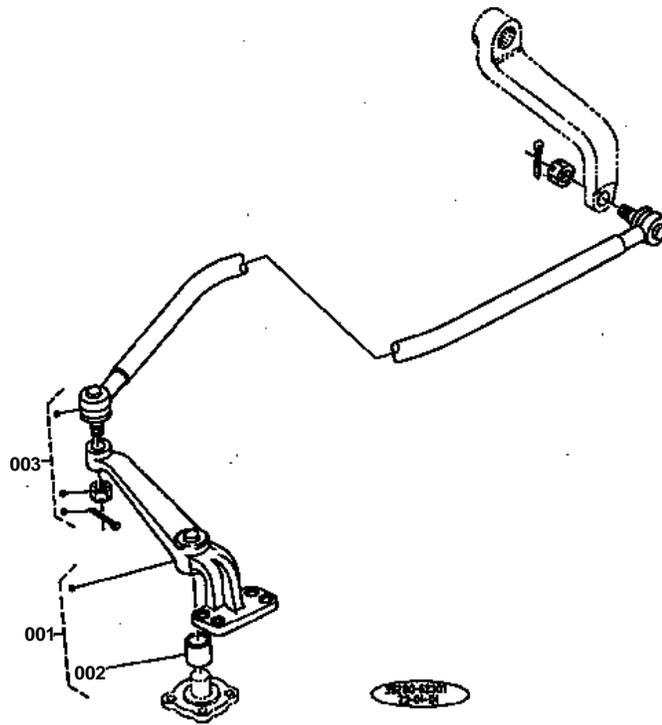



DRAG LINK [4WD]

↔ Interchangeable; ≠ not interchangeable; ← new for old; → old for new

REF.No	Part No.	Description	Q'ty	S.No.	I/C	REMARKS	Weight (kgf)	Weight (lb)
001	99999-99999	BLANK	1			ORDER BY REF.No.003	0	0
002	37800-43890	BUSH	1				0.035	0.077
003	35290-43980	ASSY LINK,DRAG	1				3	6.6

CLUTCH HOUSING

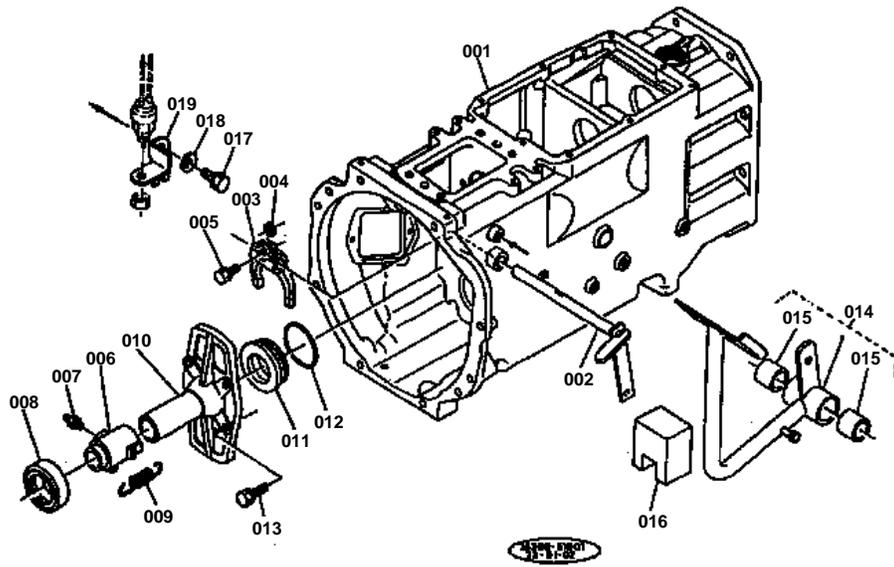

REF. No. ① 35200-1481-0

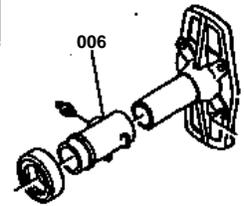

REF. No. ① 32240-1595-0

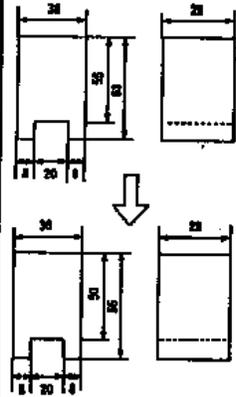

REF. No. ① 35200-1595-0



CLUTCH HOUSING

↔ Interchangeable; ≠ not interchangeable; ← new for old; → old for new

REF.No	Part No.	Description	Q'ty	S.No.	I/C	REMARKS	Weight (kgf)	Weight (lb)
001	35200-14110	HOUSING,CLUTCH	1				50.2	110.44
002	38240-14710	LEVER,CLUTCH	1	<=10164		(2WD)	0.5	1.1
002	35200-14710	LEVER,CLUTCH	1	>=10165		(2WD)	0.48	1.056
002	38240-14710	LEVER,CLUTCH	1	<=10171		(4WD)	0.5	1.1
002	35200-14710	LEVER,CLUTCH	1	>=10172		(4WD)	0.48	1.056
003	31150-14720	FORK	1				0.24	0.528
004	31150-14780	KEY,FORK	1				0.003	0.0066
005	01123-50825	BOLT	1				0.013	0.0286
006	35200-14810	HUB,CLUTCH RELEASE	1	<=10454		(2WD)	0.6	1.32
006	37220-14810	HUB,CLUTCH RELEASE	1	>=10455		(2WD)	0	0
006	35200-14810	HUB,CLUTCH RELEASE	1	<=10431		(4WD)	0.6	1.32
006	37220-14810	HUB,CLUTCH RELEASE	1	>=10432		(4WD)	0	0
007	06613-10010	NIPPLE,GREASE	1				0.006	0.0132
008	08490-00001	BEARING,THRUST BALL	1				0.227	0.4994
009	34150-14840	SPRING,	1				0.01	0.022
010	37150-15410	CASE,PROPELLER SHAFT	1				0	0
011	37150-15420	SPACER	1				0.105	0.231
012	04811-50650	O RING	1				0.002	0.0044
013	01123-50830	BOLT	4				0.015	0.033
014	37150-15710	PEDAL,CLUTCH	1				1.4	3.08
015	34150-28430	BUSH	2				0.04	0.088
016	32240-15950	PIECE,DISTANCE	1	<=10604		(2WD)	0.045	0.099
016	35200-15950	PIECE,DISTANCE	1	>=10605		(2WD)	0.03	0.066
016	32240-15950	PIECE,DISTANCE	1	<=10551		(4WD)	0.045	0.099
016	35200-15950	PIECE,DISTANCE	1	>=10552		(4WD)	0.03	0.066
017	01130-51025	BOLT	1				0	0
018	04011-50100	WASHER,PLAIN	1				0.002	0.0044
019	38240-32250	BRACKET	1				0.08	0.176

MAIN SHAFT

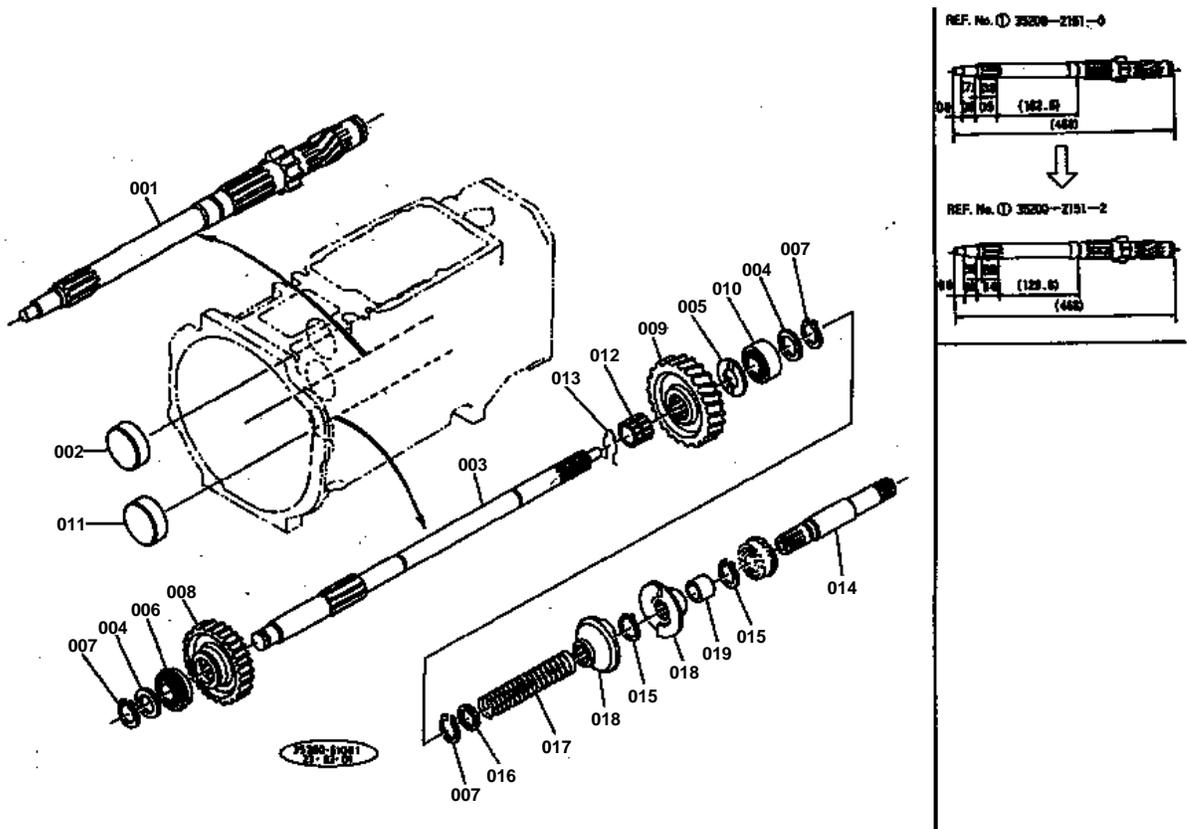



MAIN SHAFT

↔ Interchangeable; ≠ not interchangeable; ← new for old; → old for new

REF.No	Part No.	Description	Q'ty	S.No.	I/C	REMARKS	Weight (kgf)	Weight (lb)
001	35200-21510	SHAFT,MAIN	1	<=10454		(2WD)	1.965	4.323
001	35200-21512	SHAFT,MAIN	1	>=10455		(2WD)	1.935	4.257
001	35200-21510	SHAFT,MAIN	1	<=10431		(4WD)	1.965	4.323
001	35200-21512	SHAFT,MAIN	1	>=10432		(4WD)	1.935	4.257
002	34150-21650	COVER,BEARING	1				0.07	0.154
003	35200-25320	COUNTERSHAFT,PTO	1				2.115	4.653
004	34150-21560	WASHER	2				0.01	0.022
005	37150-21760	COLLAR,THRUST	1				0.017	0.0374
006	08151-06205	BEARING,BALL	1				0.131	0.2882
007	37150-21550	CIR-CLIP,EXTERNAL	3				0.06	0.132
008	35260-21730	GEAR,44	1				0.895	1.969
009	37150-21740	GEAR,45	1				1.08	2.376
010	08241-03205	BEARING,BALL	1				0	0
011	34150-21650	COVER,BEARING	1				0.07	0.154
012	37150-21750	BOSS,SPLINE	1				0.088	0.1936
013	37150-21780	RING	1				0	0
014	35200-25210	SHAFT,PTO DRIVE	1				0.79	1.738
015	37150-21550	CIR-CLIP,EXTERNAL	2				0.06	0.132
016	35200-25220	COLLAR	1				0.005	0.011
017	35200-25230	SPRING,ONE-WAY CLUTC	1				0.075	0.165
018	35200-25242	CAM,CLUTCH	2				0	0
019	35200-25250	COLLAR	1				0.04	0.088

SPEED CHANGE SYSTEM

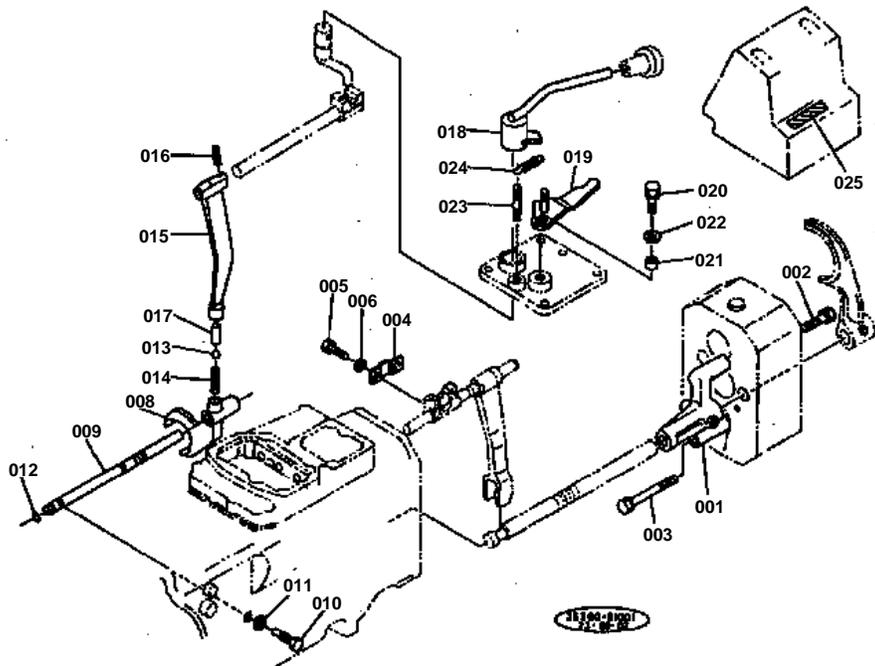

REF. No. ① 30200-2304-5



REF. No. ① 04013-50080



Discontinua.



SPEED CHANGE SYSTEM

↔ Interchangeable; ≠ not interchangeable; ← new for old; → old for new

REF.No	Part No.	Description	Q'ty	S.No.	I/C	REMARKS	Weight (kgf)	Weight (lb)
001	35200-23300	GUIDE,SHIFT ROD	1				0.47	1.034
002	01133-51030	BOLT	1				0.025	0.055
003	01133-51065	BOLT	1				0.03	0.066
004	35200-23340	PLATE	1				0.015	0.033
005	01050-50512	BOLT	2	>=10001			0.003	0.0066
005	01050-50510	BOLT	2	>=10001			0.003	0.0066
006	04512-50050	WASHER,SPRING	2				0	0
007	04013-50050	WASHER,PLAIN	4	<=10454			0	0
007	04013-50050	WASHER,PLAIN	4	<=10431			0	0
008	37150-24610	FORK,SHIFT	1				0.21	0.462
009	35200-24630	SHAFT,FORK	1				0.16	0.352
010	34150-24680	SCREW,SET	1				0.015	0.033
011	04717-00800	WASHER,SEAL	1				0.001	0.0022
012	04811-00090	O RING	1				0.001	0.0022
013	07715-01605	BALL	1				0.003	0.0066
014	62231-18530	SPRING	1				0.01	0.022
015	35200-24710	LEVER,PTO	1				0.2	0.44
016	05411-00425	PIN,SPRING	1				0.001	0.0022
017	34150-24690	PIN	1				0.02	0.044
018	35200-24850	LEVER,PTO	1				0.22	0.484
019	35260-24900	LEVER,CHECK	1				0.095	0.209
020	01170-51020	BOLT	1				0	0
021	35260-24910	COLLAR	1				0.003	0.0066
022	04013-50100	WASHER,PLAIN	2				0	0
023	35260-24920	HOOK	1				0.005	0.011
024	34370-15770	SPRING	1				0.004	0.0088
025	35200-24950	LABEL,PTO	1				0.001	0.0022

CLUTCH HOUSING

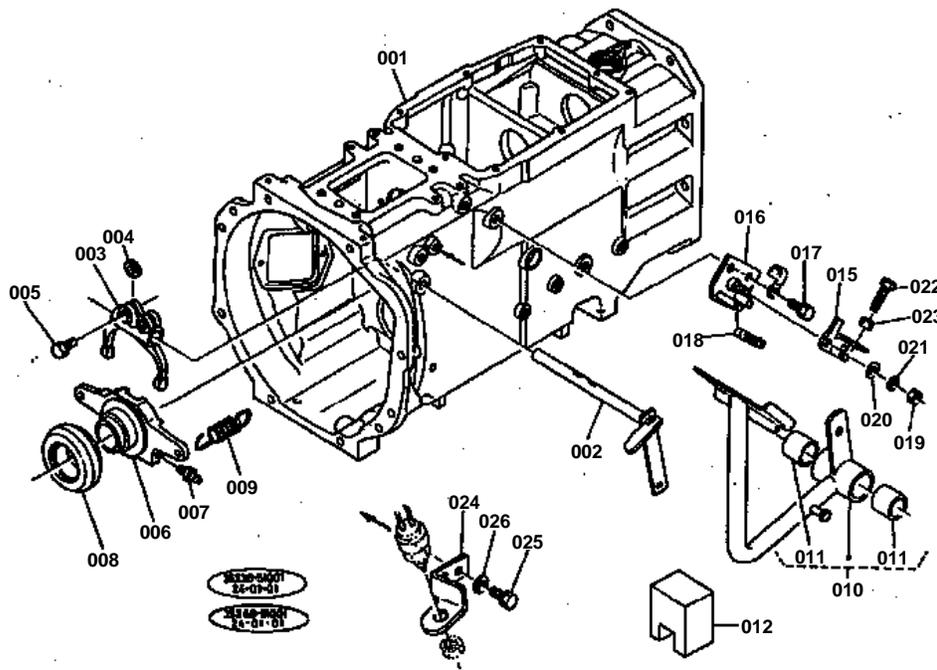

REF. No. 35340-1595-0

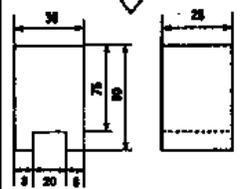
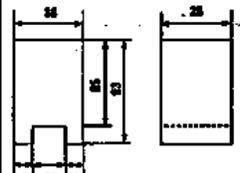

REF. No. 35280-1595-0



CLUTCH HOUSING

↔ Interchangeable; ≠ not interchangeable; ← new for old; → old for new

REF.No	Part No.	Description	Q'ty	S.No.	I/C	REMARKS	Weight (kgf)	Weight (lb)
001	35260-14110	HOUSING,CLUTCH	1				61	134.2
002	38430-14710	LEVER,CLUTCH	1				0.54	1.188
003	38430-14720	FORK,CLUTCH RELEASE	1				0.41	0.902
004	31150-14780	KEY,FORK	2				0.003	0.0066
005	01123-50830	BOLT	2				0.015	0.033
006	38260-14810	HUB,CLUTCH RELEASE	1				0.65	1.43
007	06613-10675	NIPPLE,GREASE	1				0.003	0.0066
008	38430-14820	BEARING,THRUST BALL	1				0.27	0.594
009	38430-14840	SPRING	2				0.004	0.0088
010	35260-15720	PEDAL,CLUTCH	1				1.55	3.41
011	38180-28670	BUSH	2				0.02	0.044
012	35340-15950	PIECE,DISTANCE	1	<=10604		(2WD)	0.04	0.088
012	35260-15950	PIECE,DISTANCE	1	>=10605		(2WD)	0.05	0.11
012	35340-15950	PIECE,DISTANCE	1	<=10551		(4WD)	0.04	0.088
012	35260-15950	PIECE,DISTANCE	1	>=10552		(4WD)	0.05	0.11
013	99999-99999	BLANK	0				0	0
014	99999-99999	BLANK	0				0	0
015	35260-15810	STOPPER,PEDAL	1				0.1	0.22
016	35260-15820	STAY,STOPPER	1				0.2	0.44
017	01130-51020	BOLT	2				0	0
018	34370-15770	SPRING	1				0.004	0.0088
019	02114-50080	NUT	1				0.005	0.011
020	04012-50080	WASHER,PLAIN	1				0.001	0.0022
021	04512-50080	WASHER,SPRING	1				0.001	0.0022
022	01172-51035	BOLT	1				0.03	0.066
023	02118-50100	NUT	1				0.005	0.011
024	35260-32250	BRACKET	1				0.105	0.231
025	01130-51020	BOLT	2				0	0
026	04011-50100	WASHER,PLAIN	2				0.002	0.0044

GEAR CASE

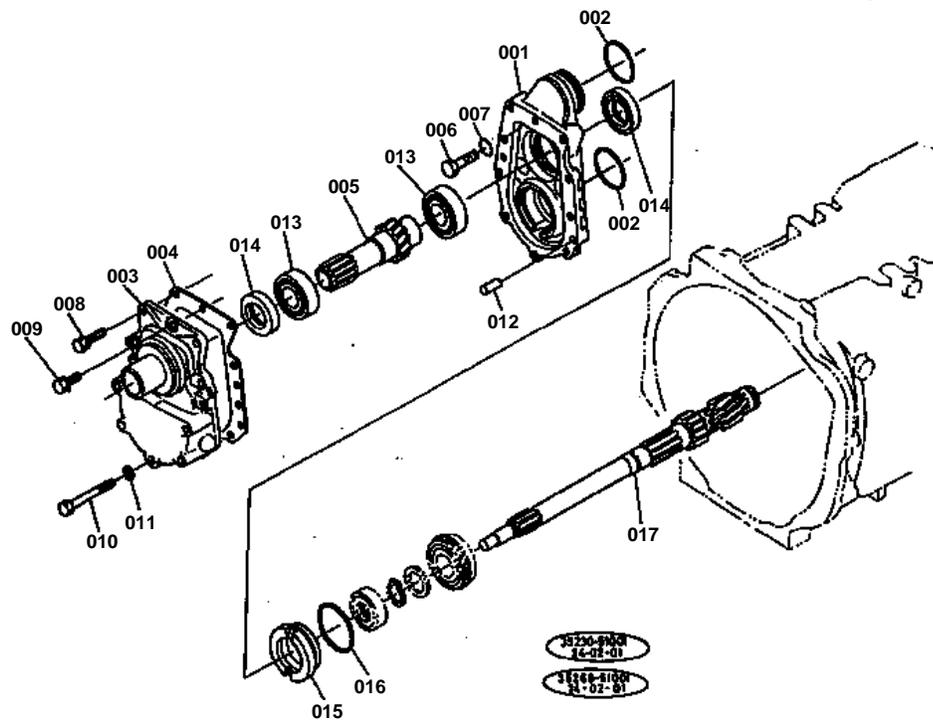



GEAR CASE

↔ Interchangeable; ≠ not interchangeable; ← new for old; → old for new

REF.No	Part No.	Description	Q'ty	S.No.	I/C	REMARKS	Weight (kgf)	Weight (lb)
001	38430-21310	CASE,GEAR	1				3	6.6
002	04811-50550	O RING	2				0.002	0.0044
003	35260-21320	COVER,GEAR CASE	1				0.79	1.738
004	38430-21330	GASKET	1				0.01	0.022
005	35260-21350	SHAFT,16 GEAR	1				0.58	1.276
006	38430-21340	BOLT	4				0.04	0.088
007	04811-00100	O RING	4				0.001	0.0022
008	01123-50830	BOLT	4				0.015	0.033
009	01123-50820	BOLT	1				0.011	0.0242
010	01153-50860	BOLT	5				0.024	0.0528
011	04512-50080	WASHER,SPRING	5				0.001	0.0022
012	05012-00818	PIN,STRAIGHT	2				0.008	0.0176
013	38430-21580	BEARING,BALL	2				0	0
014	09500-35558	SEAL,OIL	2				0.02	0.044
015	35340-15420	SPACER 1	1				0.275	0.605
016	04811-50650	O RING	1				0.002	0.0044
017	35260-21510	SHAFT,MAIN	1				0.16	0.352

PTO COUNTER SHAFT

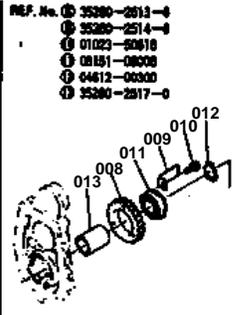
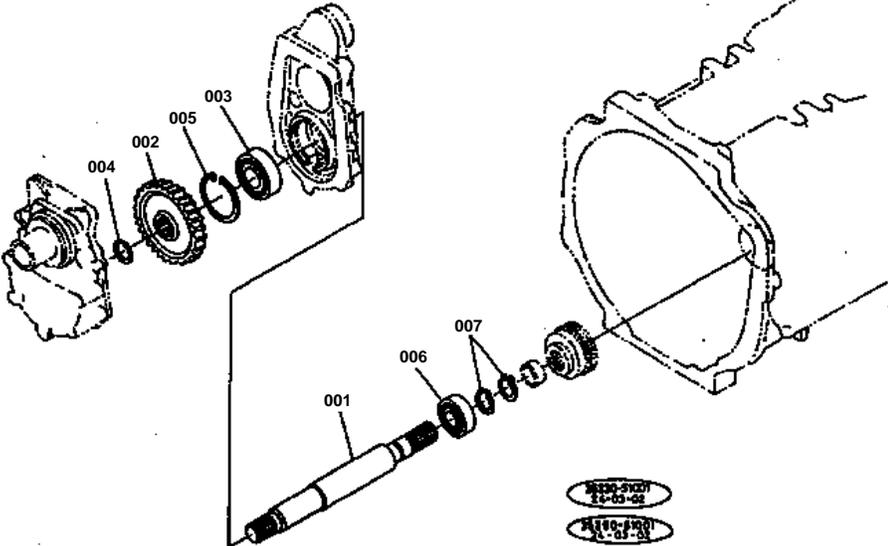



PTO COUNTER SHAFT

↔ Interchangeable; ≠ not interchangeable; ← new for old; → old for new

REF.No	Part No.	Description	Q'ty	S.No.	I/C	REMARKS	Weight (kgf)	Weight (lb)
001	35260-25110	COUNTERSHAFT,PTO 1	1				1.645	3.619
002	35260-25120	GEAR,39	1				0.69	1.518
003	08101-06305	BEARING,BALL	1				0.23	0.506
004	38430-21550	CIR-CLIP,EXTERNAL	1				0.005	0.011
005	04611-00620	CIR-CLIP,INTERNAL	1				0.011	0.0242
006	08101-06205	BEARING,BALL	1				0.14	0.308
007	37150-21550	CIR-CLIP,EXTERNAL	2				0.06	0.132
008	35260-25130	GEAR,31	1	≤10604		(2WD)	0.36	0.792
008	35260-25130	GEAR,31	1	≤10551		(4WD)	0.36	0.792
009	35260-25140	BRAKE,FAN	3	≤10604		(2WD)	0.023	0.0506
009	35260-25140	BRAKE,FAN	3	≤10551		(4WD)	0.023	0.0506
010	01023-50616	BOLT	3	≤10604		(2WD)	0.005	0.011
010	01023-50616	BOLT	3	≤10551		(4WD)	0.005	0.011
011	08151-06006	BEARING,BALL	1	≤10604		(2WD)	0.12	0.264
011	08151-06006	BEARING,BALL	1	≤10551		(4WD)	0.12	0.264
012	04612-00300	CIR-CLIP,EXTERNAL	1	≤10604		(2WD)	0.003	0.0066
012	04612-00300	CIR-CLIP,EXTERNAL	1	≤10551		(4WD)	0.003	0.0066
013	35260-25170	COLLAR	1	≤10604		(2WD)	0.19	0.418
013	35260-25170	COLLAR	1	≤10551		(4WD)	0.19	0.418

PTO GEAR CASE

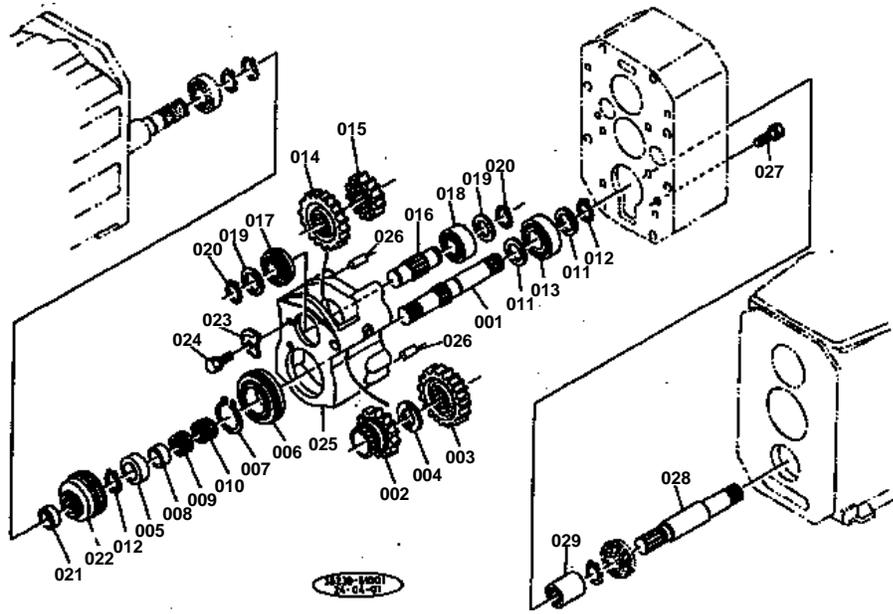



PTO GEAR CASE

↔ Interchangeable; ≠ not interchangeable; ← new for old; → old for new

REF.No	Part No.	Description	Q'ty	S.No.	I/C	REMARKS	Weight (kgf)	Weight (lb)
001	35260-25160	COUNTERSHAFT,PTO 2	1				0.73	1.606
002	38260-25170	GEAR,16	1				0.48	1.056
003	35260-25190	GEAR,22	1				0.67	1.474
004	38240-21760	COLLAR,THRUST	1				0.02	0.044
005	35260-25240	COLLAR	1				0.098	0.2156
006	08153-06009	BEARING,BALL	1				0.25	0.55
007	04612-00450	CIR-CLIP,EXTERNAL	1				0.007	0.0154
008	38260-25250	COLLAR	1				0.02	0.044
009	08822-53114	BEARING,NEEDLE	1				0.02	0.044
010	08822-53117	BEARING,NEEDLE	1				0.025	0.055
011	34150-21560	WASHER	2				0.01	0.022
012	38430-21550	CIR-CLIP,EXTERNAL	2				0.005	0.011
013	08101-06305	BEARING,BALL	1				0.23	0.506
014	38260-25260	GEAR,20	1				0.48	1.056
015	35260-25280	GEAR,15	1				0.34	0.748
016	35260-25290	SHAFT,PTO GEAR	1				0.375	0.825
017	38430-21690	BEARING,BALL	1				0.13	0.286
018	08241-03205	BEARING,BALL	1				0	0
019	34150-21560	WASHER	2				0.01	0.022
020	38430-21550	CIR-CLIP,EXTERNAL	2				0.005	0.011
021	35260-25200	COLLAR	1				0.03	0.066
022	38260-25510	SHIFTER	1				0.45	0.99
023	34150-21942	RETAINER,BEARING	2				0.035	0.077
024	01123-50820	BOLT	2				0.011	0.0242
025	35260-25150	CASE,PTO GEAR	1				4.3	9.46
026	05012-01018	PIN,STRAIGHT	2				0.012	0.0264
027	01123-51030	BOLT	4				0.025	0.055
028	38260-25210	SHAFT,PTO DRIVE	1				0.75	1.65
029	37150-21680	COUPLING	1				0	0

PTO SHIFT FORK

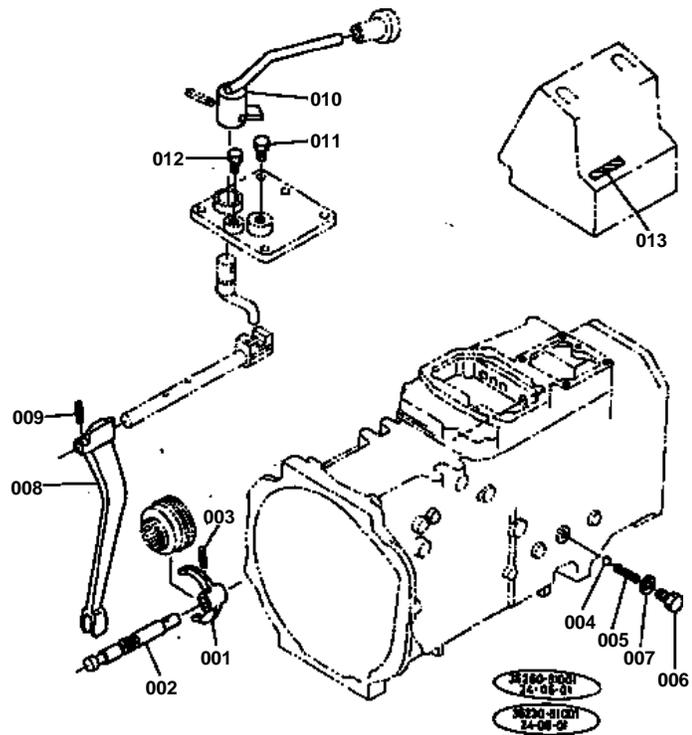



PTO SHIFT FORK

↔ Interchangeable; ≠ not interchangeable; ← new for old; → old for new

REF.No	Part No.	Description	Q'ty	S.No.	I/C	REMARKS	Weight (kgf)	Weight (lb)
001	38260-24610	FORK,SHIFT FRONT	1				0.11	0.242
002	38260-24632	ROD,FORK FRONT	1				0.185	0.407
003	05411-00425	PIN,SPRING	1				0.001	0.0022
004	07715-01605	BALL	3				0.003	0.0066
005	62231-18530	SPRING	2				0.01	0.022
006	37110-24680	PLUG	1				0.015	0.033
007	04717-01000	WASHER,SEAL	1				0.001	0.0022
008	35260-24710	LEVER,PTO	1				0.58	1.276
009	05411-00420	PIN,SPRING	1				0.001	0.0022
010	35260-24853	LEVER,PTO	1				0.2	0.44
011	01170-51020	BOLT	1				0	0
012	01150-50812	BOLT	1				0.009	0.0198
013	35260-24950	LABEL PTO	1				0.002	0.0044

HITCH

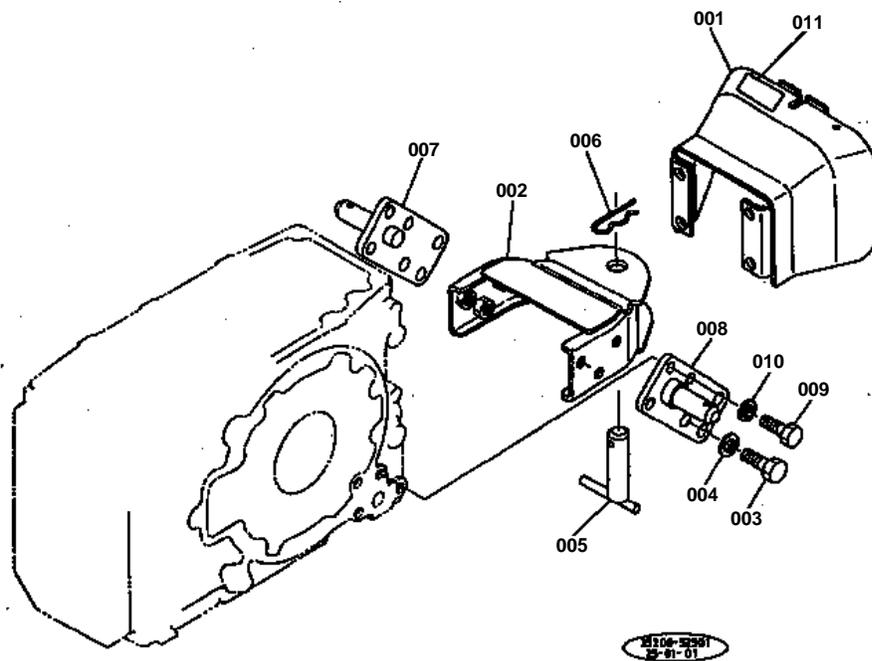



HITCH

↔ Interchangeable; ≠ not interchangeable; ← new for old; → old for new

REF.No	Part No.	Description	Q'ty	S.No.	I/C	REMARKS	Weight (kgf)	Weight (lb)
001	35244-25330	PROTECTOR,PTO SHAFT	1				2.28	5.016
002	35110-29710	HITCH	1				3.15	6.93
003	01173-51430	BOLT	6				0.052	0.1144
004	04512-50140	WASHER,SPRING	6				0	0
005	35110-29720	PIN,HITCH	1				0.38	0.836
006	70515-16330	PIN,SPRING	1				0.028	0.0616
007	35110-29730	BRACKET,HITCH RH	1				0.85	1.87
008	35110-29740	BRACKET,HITCH LH	1				0.88	1.936
009	01173-51230	BOLT	6				0.037	0.0814
010	04512-50120	WASHER,SPRING	6				0	0
011	35200-25340	LABEL PTO	1	>=10605		(2WD)	0.002	0.0044
011	35200-25340	LABEL PTO	1	>=10552		(4WD)	0.002	0.0044

MAIN SPEED CHANGE GUIDE

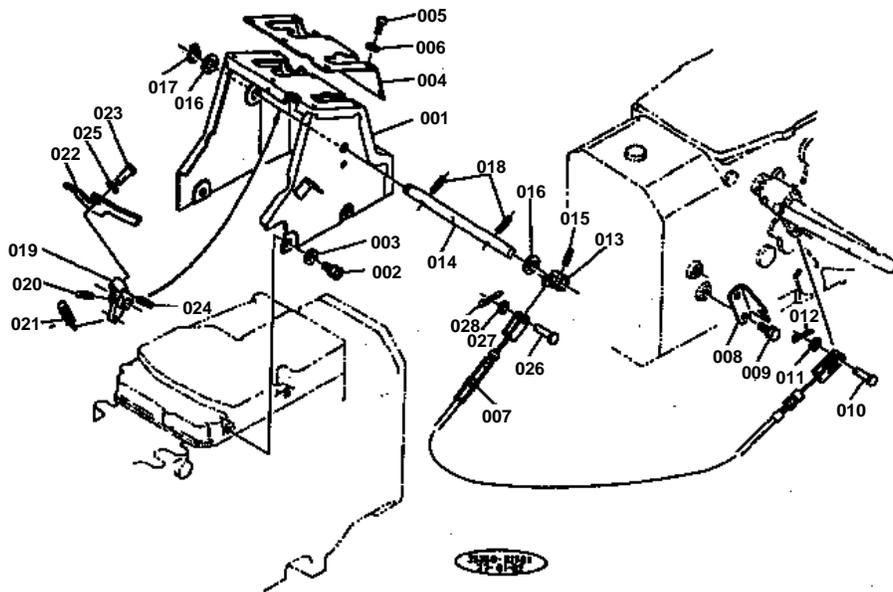



MAIN SPEED CHANGE GUIDE

↔ Interchangeable; ≠ not interchangeable; ← new for old; → old for new

REF.No	Part No.	Description	Q'ty	S.No.	I/C	REMARKS	Weight (kgf)	Weight (lb)
001	35260-24930	GUIDE,MAIN S-CHANGE	1				1.72	3.784
002	01202-50816	BOLT	4				0.012	0.0264
003	04012-50080	WASHER,PLAIN	4				0.001	0.0022
004	35260-24940	MARK,S-CHANGE PATTERN	1				0	0
005	03714-50410	SCREW,TAPPING	9				0.002	0.0044
006	04012-50040	WASHER,PLAIN	9				0.001	0.0022
007	35260-24960	ASSY WIRE,CHECK	1				0.225	0.495
008	35260-24970	CLAMP,WIRE	1				0.07	0.154
009	01123-50816	BOLT	2				0.011	0.0242
010	05122-50616	PIN,JOINT	2				0.004	0.0088
010	05122-50616	PIN,JOINT	1				0.004	0.0088
011	04012-50060	WASHER,PLAIN	2				0.001	0.0022
011	04012-50060	WASHER,PLAIN	1				0.001	0.0022
012	05511-51612	PIN,SPLIT	2				0.001	0.0022
012	05511-51612	PIN,SPLIT	1				0.001	0.0022
013	35260-24980	LEVER,CHECK 1	1				0.05	0.11
014	35260-24990	SHAFT,CHECK	1				0.26	0.572
015	05411-00425	PIN,SPRING	1				0.001	0.0022
016	04011-50140	WASHER,PLAIN	2				0.007	0.0154
017	04612-00140	CIR-CLIP,EXTERNAL	1				0.001	0.0022
018	05411-00428	PIN,SPRING	2				0.002	0.0044
019	35260-25000	LEVER	1				0.095	0.209
020	05411-00425	PIN,SPRING	1				0.001	0.0022
021	35260-25010	SPRING	1				0.005	0.011
022	35260-25020	LEVER,CHECK 2	1				0.165	0.363
023	35260-25030	PIN	1				0.015	0.033
024	05411-00325	PIN,SPRING	1				0.001	0.0022
025	04013-50100	WASHER,PLAIN	1				0	0
026	05122-50616	PIN,JOINT	1	>=10001			0.004	0.0088
026	05122-50616	PIN,JOINT	1	>=10001			0.004	0.0088
027	04012-50060	WASHER,PLAIN	1	>=10001			0.001	0.0022
027	04012-50060	WASHER,PLAIN	1	>=10001			0.001	0.0022
028	05511-51612	PIN,SPLIT	1	>=10001			0.001	0.0022
028	05511-51612	PIN,SPLIT	1	>=10001			0.001	0.0022

SEAT

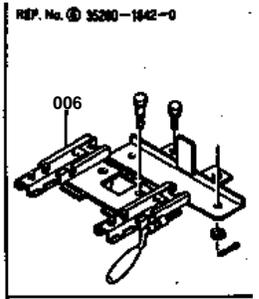
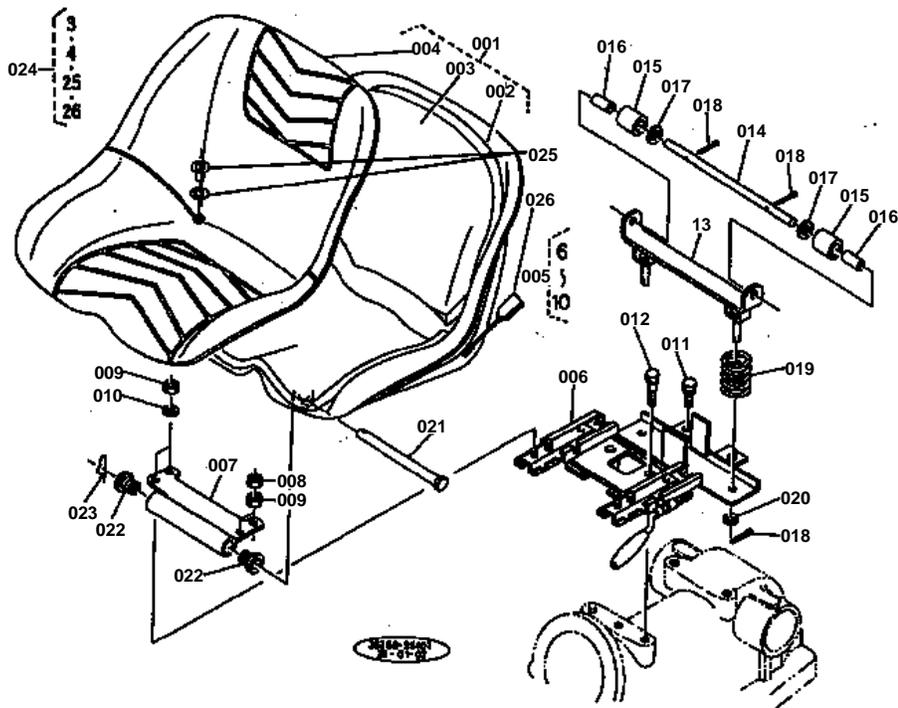



SEAT

↔ Interchangeable; ≠ not interchangeable; ← new for old; → old for new

REF.No	Part No.	Description	Q'ty	S.No.	I/C	REMARKS	Weight (kgf)	Weight (lb)
001	35260-85010	ASSY SEAT	1				6	13.2
002	35260-85020	PAN,SEAT	1				0	0
003	99999-99999	BLANK	1			ORDER BY REF.No.001 OR 024	0	0
004	99999-99999	BLANK	1			ORDER BY REF.No.001 OR 024	0	0
005	35260-18413	ASSY ADJUSTER, SEAT	1				0	0
006	35260-18420	ADJUSTER,SEAT	1				2.8	6.16
007	35260-18430	SUPPORT,SEAT	1				0.54	1.188
008	02112-50080	NUT	2				0.003	0.0066
009	02114-50080	NUT	4				0.005	0.011
010	04512-50080	WASHER,SPRING	2				0.001	0.0022
011	01133-51025	BOLT	2				0.023	0.0506
012	01133-51045	BOLT	2				0.034	0.0748
013	35260-18480	BRACKET,CUSHION	1				0.5	1.1
014	35260-18490	SHAFT,CUSHION SET	1				0.13	0.286
015	38240-18440	CUSHION	2				0.035	0.077
016	35260-18500	COLLAR	2				0.018	0.0396
017	04013-50100	WASHER,PLAIN	2				0	0
018	05511-50315	PIN,SPLIT	4				0.002	0.0044
019	66204-45980	SPRING,SEAT	2				0.1	0.22
020	04012-50080	WASHER,PLAIN	2	≥10001			0.001	0.0022
020	04015-50080	WASHER,PLAIN	2	≥10001			0	0
021	38240-18470	PIN,SET	1				0.085	0.187
022	37150-18490	CUSHION	2				0.014	0.0308
023	05515-51000	PIN,SNAP	1				0	0
024	35110-99100	ASSY COVER,SEAT	1	≥10605			0.52	1.144
024	35110-99100	ASSY COVER,SEAT	1	≥10552			0.52	1.144
025	35110-85050	EYE-LET	4	≥10605			0.005	0.011
025	35110-85050	EYE-LET	4	≥10552			0.005	0.011
026	35110-85060	PROTECTOR	3	≥10605			0.01	0.022
026	35110-85060	PROTECTOR	3	≥10552			0.01	0.022

TAIL LAMP

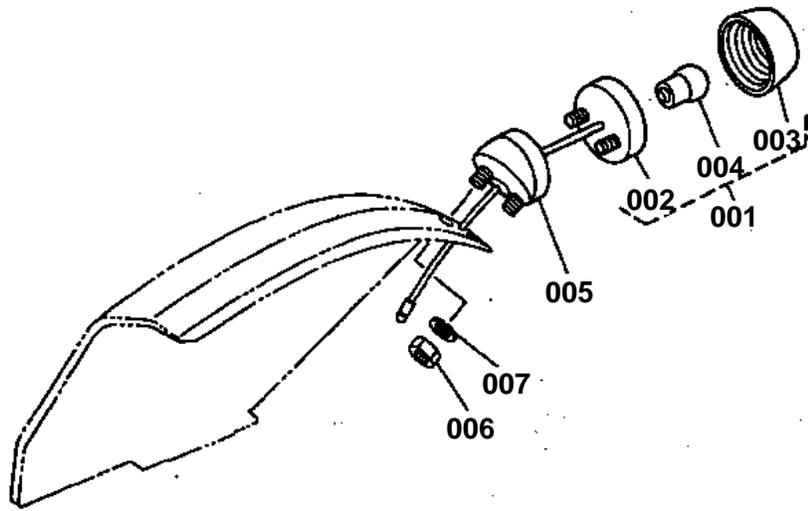

36170-53501
29-01-01

**TAIL LAMP**

↔ Interchangeable; ≠ not interchangeable; ← new for old; → old for new

REF.No	Part No.	Description	Q'ty	S.No.	I/C	REMARKS	Weight (kgf)	Weight (lb)
001	34350-34100	ASSY LAMP,TAIL	2				0.13	0.286
002	99999-99999	BLANK	2			ORDER BY REF.No.001	0	0
003	34350-34120	LENS,LAMP	2				0.05	0.11
004	34350-34140	BULB,LAMP	2				0.008	0.0176
005	34350-34190	HOLDER,TAIL LAMP	2				0.107	0.2354
006	02014-50060	NUT	4				0.003	0.0066
007	04512-50060	WASHER,SPRING	4				0	0

HAZARD LAMP

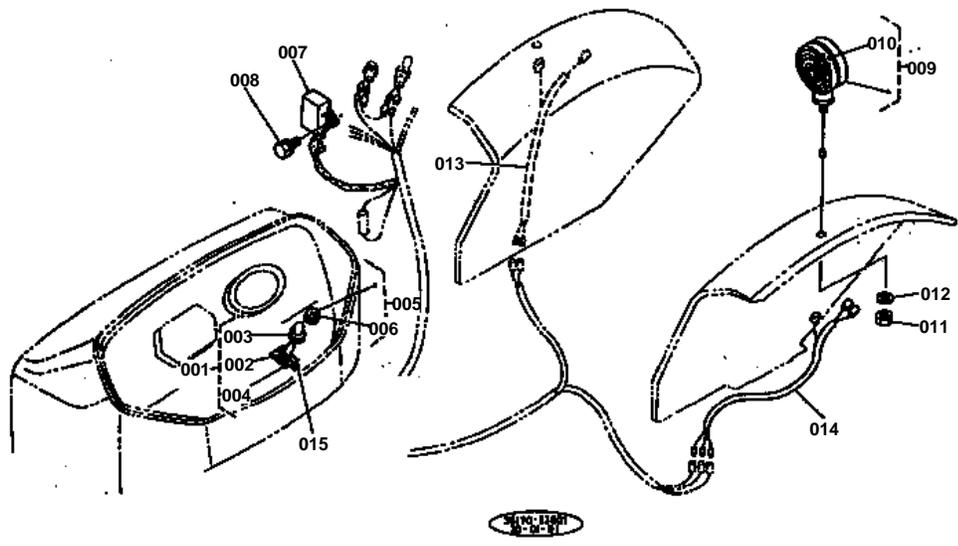



HAZARD LAMP

↔ Interchangeable; ≠ not interchangeable; ← new for old; → old for new

REF.No	Part No.	Description	Q'ty	S.No.	I/C	REMARKS	Weight (kgf)	Weight (lb)
001	54721-41300	ASSY SWITCH	1				0.03	0.066
002	99999-99999	BLANK	1			ORDER BY REF.No.001	0	0
003	54721-22330	CAP	1				0.002	0.0044
004	54721-22340	LABEL	1				0.001	0.0022
005	66711-55290	ASSY OIL LAMP	1				0.016	0.0352
006	34150-34590	BULB	1				0.001	0.0022
007	35170-33700	FLASHER	1				0.06	0.132
008	01202-50616	BOLT	1				0.006	0.0132
009	35450-75010	ASSY LAMP HAZARD FLA	2				0.3	0.66
010	35450-75022	VALVE HAZARD FLASHER	2				0.008	0.0176
011	02114-50100	NUT	2				0.005	0.011
012	04512-50100	WASHER,SPRING	2				0	0
013	35170-34360	WIRE HARNESS 6	1				0.025	0.055
014	35170-34370	WIRE HARNESS 7	1				0.035	0.077
015	35320-31840	LABEL	1				0.005	0.011

S.M.V. EMBLEM BRACKET

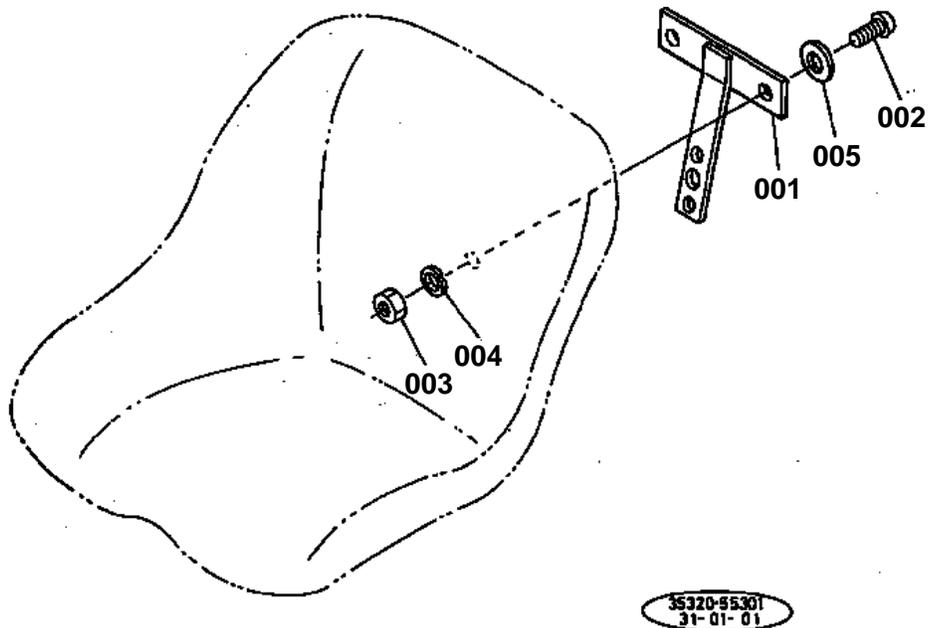



S.M.V.EMBLEM BRACKET

↔ Interchangeable; ≠ not interchangeable; ← new for old; → old for new

REF.No	Part No.	Description	Q'ty	S.No.	I/C	REMARKS	Weight (kgf)	Weight (lb)
001	35320-18480	BRACKET	1				0.22	0.484
002	01050-50614	BOLT	2				0	0
003	02014-50060	NUT	2				0.003	0.0066
004	04512-50060	WASHER,SPRING	2				0	0
005	04012-50060	WASHER,PLAIN	2				0.001	0.0022

FENDER

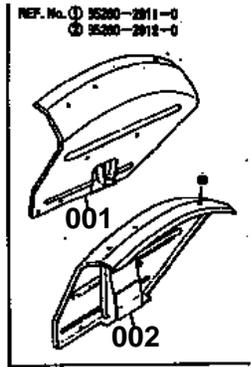
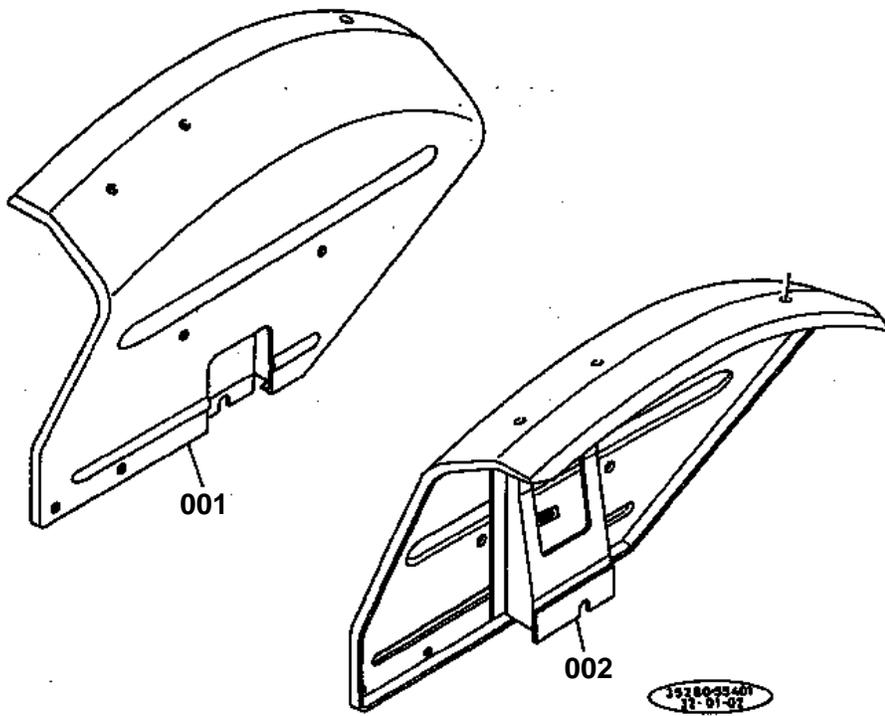



FENDER

↔ Interchangeable; ≠ not interchangeable; ← new for old; → old for new

REF.No	Part No.	Description	Q'ty	S.No.	I/C	REMARKS	Weight (kgf)	Weight (lb)
001	35260-29110	ASSY FENDER RH	1	≤10454		(2WD)	0	0
001	35260-29114	ASSY FENDER RH	1	≥10455		(2WD)	0	0
001	35260-29110	ASSY FENDER RH	1	≤10431		(4WD)	0	0
001	35260-29114	ASSY FENDER RH	1	≥10432		(4WD)	0	0
002	35260-29120	ASSY FENDER LH	1	≤10454		(2WD)	0	0
002	35260-29124	ASSY FENDER LH	1	≥10455		(2WD)	0	0
002	35260-29120	ASSY FENDER LH	1	≤10431		(4WD)	0	0
002	35260-29124	ASSY FENDER LH	1	≥10432		(4WD)	0	0

BALUSTRADE

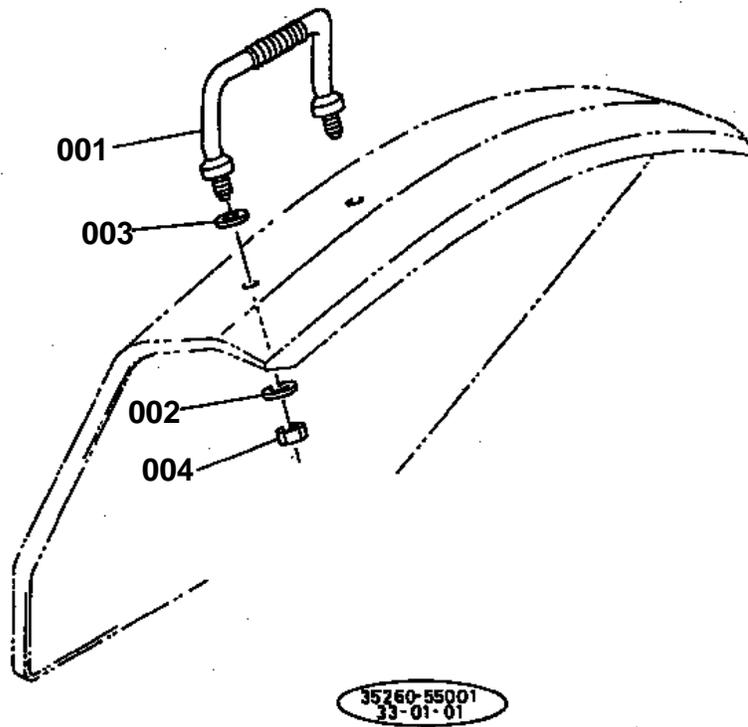

**BALUSTRIDE**

↔ Interchangeable; ≠ not interchangeable; ← new for old; → old for new

REF.No	Part No.	Description	Q'ty	S.No.	I/C	REMARKS	Weight (kgf)	Weight (lb)
001	35260-29190	RAIL,HAND	2				0.27	0.594
002	04013-50140	WASHER,PLAIN	4				0	0
003	32260-29180	CUSHION	4				0.005	0.011
004	02174-50140	NUT	4				0.014	0.0308

AIR CLEANER

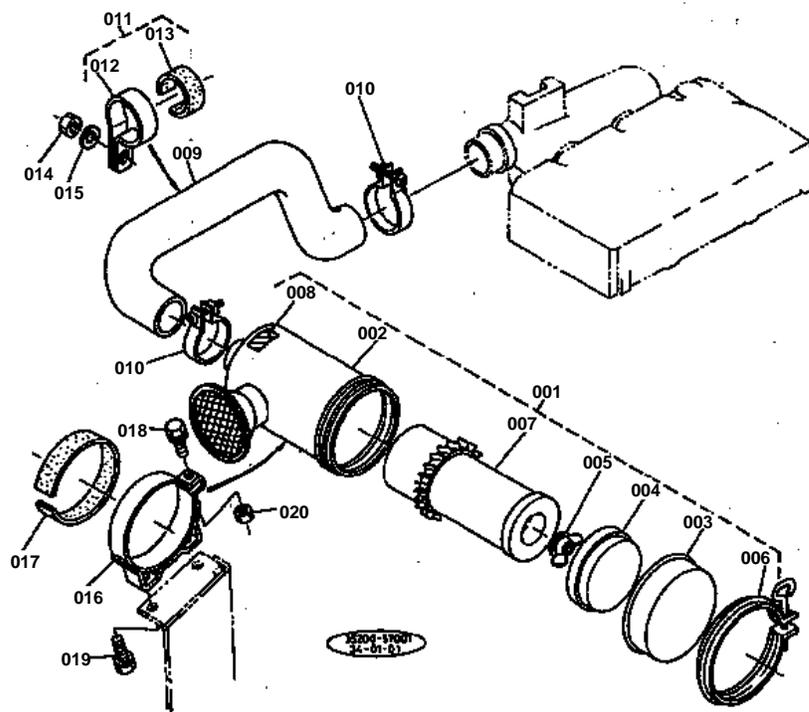



AIR CLEANER

↔ Interchangeable; ≠ not interchangeable; ← new for old; → old for new

REF.No	Part No.	Description	Q'ty	S.No.	I/C	REMARKS	Weight (kgf)	Weight (lb)
001	15222-11012	ASSY CLEANER,AIR	1				1.4	3.08
002	15222-11150	BODY,AIR CLEANER	1				0.708	1.5576
003	15222-11160	COVER,AIR CLEANER	1				0.202	0.4444
004	15222-11410	COVER,BAFFLE	1				0.043	0.0946
005	15222-92620	NUT,WING	1				0.02	0.044
006	15222-11070	ASSY BAND,AIR CLEANE	1				0.098	0.2156
007	15222-11220	ELEMENT,AIR CLEANER	1				0.344	0.7568
008	15222-87750	MARK,FORM	1				0.001	0.0022
009	15575-11620	PIPE,INLET	1				0.58	1.276
010	15221-11722	BAND,PIPE	2				0	0
011	15321-11700	ASSY HOLDER,INLET PI	1				0.07	0.154
012	15321-11710	HOLDER,INLET PIPE	1				0.055	0.121
013	15321-11690	PROTECTOR,INLET PIPE	1				0.02	0.044
014	02156-50080	NUT	1				0.004	0.0088
015	04512-50080	WASHER,SPRING	1				0.001	0.0022
016	34150-13960	BAND,AIR CLEANER	1				0.178	0.3916
017	34150-13970	CUSHION	1				0.02	0.044
018	01222-50840	BOLT	1				0.017	0.0374
019	01120-50816	BOLT	2				0	0
020	02114-50080	NUT	1				0.005	0.011

UPPER MUFFLER [4WD]

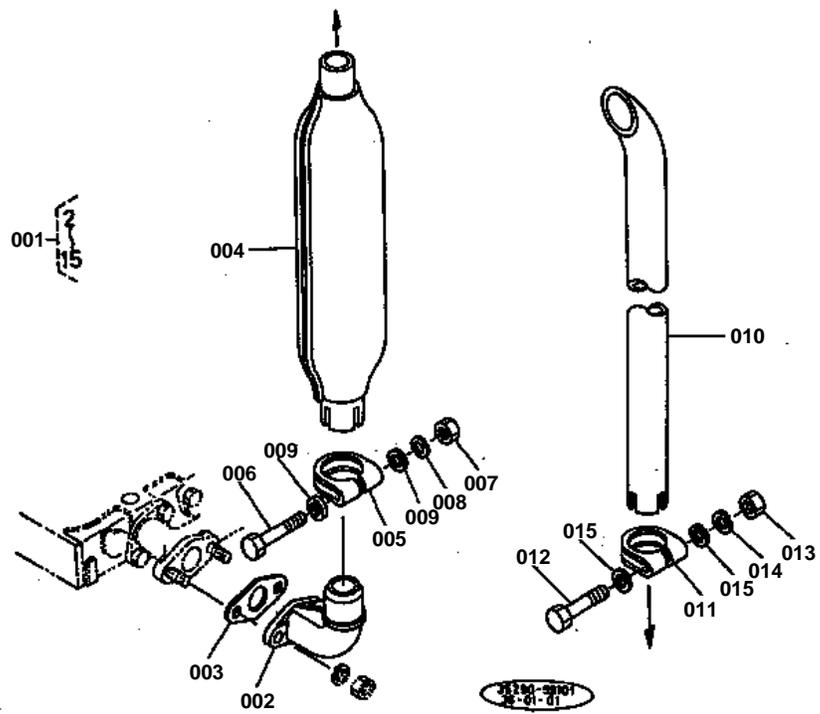

**UPPER MUFFLER [4WD]**

↔ Interchangeable; ≠ not interchangeable; ← new for old; → old for new

REF.No	Part No.	Description	Q'ty	S.No.	I/C	REMARKS	Weight (kgf)	Weight (lb)
001	35290-63100	ASSY MUFFLER	1				3.85	8.47
002	15575-12320	FLANGE,MUFFLER	1				0.75	1.65
003	15221-12370	GASKET,MUFFLER FLANG	1				0	0
004	15575-12110	MUFFLER	1				0	0
005	15575-12130	BAND,MUFFLER	1				0	0
006	01153-50880	BOLT	1				0.03	0.066
007	02156-50080	NUT	1				0.004	0.0088
008	04512-50080	WASHER,SPRING	1				0.001	0.0022
009	04012-50080	WASHER,PLAIN	2				0.001	0.0022
010	35290-12410	MANIFOLD,EXHAUST 1	1				0	0
011	15575-12430	BAND	1				0	0
012	01153-50860	BOLT	1				0.024	0.0528
013	02156-50080	NUT	1				0.004	0.0088
014	04512-50080	WASHER,SPRING	1				0.001	0.0022
015	04012-50080	WASHER,PLAIN	2				0.001	0.0022

UNDER MUFFLER

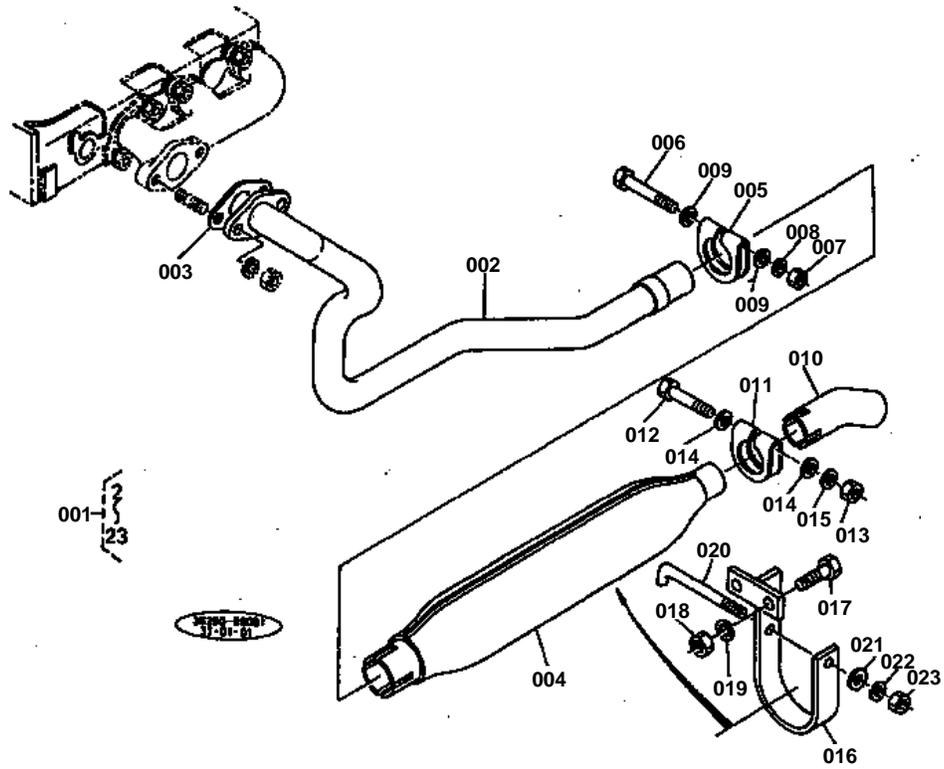



UNDER MUFFLER

↔ Interchangeable; ≠ not interchangeable; ← new for old; → old for new

REF.No	Part No.	Description	Q'ty	S.No.	I/C	REMARKS	Weight (kgf)	Weight (lb)
001	35290-62100	ASSY MUFFLER	1				8.05	17.71
002	35290-62110	PIPE,MUFFLER 1	1				2.05	4.51
003	15221-12370	GASKET	1				0	0
004	15575-12110	MUFFLER	1				0	0
005	15575-12130	BAND	1				0	0
006	01153-50880	BOLT	1				0.03	0.066
007	02156-50080	NUT	1				0.004	0.0088
008	04512-50080	WASHER,SPRING	1				0.001	0.0022
009	04012-50080	WASHER,PLAIN	2				0.001	0.0022
010	35290-62130	PIPE,MUFFLER 2	1				0	0
011	15575-12430	BAND	1				0	0
012	01153-50865	BOLT	1				0.025	0.055
013	02156-50080	NUT	1				0.004	0.0088
014	04012-50080	WASHER,PLAIN	2				0.001	0.0022
015	04512-50080	WASHER,SPRING	1				0.001	0.0022
016	35290-62160	SUPPORT,MUFFLER	1				0.46	1.012
017	01173-51020	BOLT	2				0.017	0.0374
018	02118-50100	NUT	2				0.005	0.011
019	04512-50100	WASHER,SPRING	2				0	0
020	35110-62170	BOLT	1				0.05	0.11
021	04013-50080	WASHER,PLAIN	1				0	0
022	04512-50080	WASHER,SPRING	1				0.001	0.0022
023	02054-50080	NUT	1				0.005	0.011

LABEL

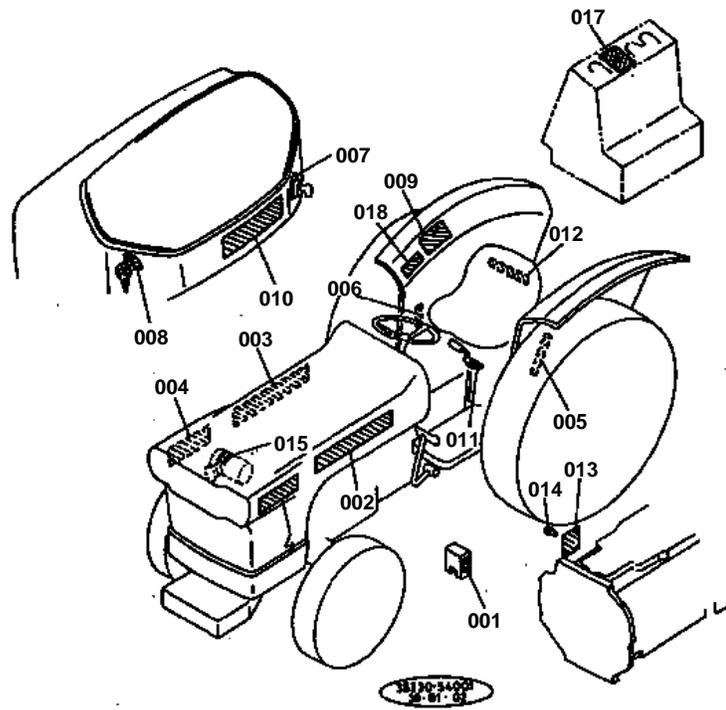



LABEL

↔ Interchangeable; ≠ not interchangeable; ← new for old; → old for new

REF.No	Part No.	Description	Q'ty	S.No.	I/C	REMARKS	Weight (kgf)	Weight (lb)
001	35176-15930	LABEL,PEDAL	1				0.005	0.011
002	35200-18280	MARK,SIDE KUBOTA LH	1				0.015	0.033
003	35200-18290	MARK,SIDE KUBOTA RH	1				0.02	0.044
004	35290-18810	LABEL,4WD	2				0.005	0.011
005	35340-24580	LABEL,AUX S-CHANGE	1				0.001	0.0022
006	35176-26690	LABEL,DIFF LOCK	1				0.001	0.0022
007	35260-31830	LABEL,MAIN SWITCH	1				0.005	0.011
008	35260-32110	LABEL,LAMP SWITCH	1				0.005	0.011
009	35176-34910	LABEL,SAFETY	1	≤10264		(2WD)	0.01	0.022
009	35176-34910	LABEL,SAFETY	1	≤10281		(4WD)	0.01	0.022
009	35260-34910	LABEL,SAFETY	1	≥10001		(2WD)	0	0
009	35260-34910	LABEL,SAFETY	1	≥10001		(4WD)	0	0
010	35176-34920	LABEL,INSTRUCTION	1				0.005	0.011
011	35290-44900	LABEL,CHANGE	1			(4WD)	0.001	0.0022
012	32140-18470	MARK,KUBOTA	1				0.002	0.0044
013	35230-19830	NAME PLATE,BODY 1	1	≥10001		(4WD)	0	0
013	35260-19830	NAME PLATE,BODY 1	1	≥10001		(4WD)	0.015	0.033
013	35200-19830	NAME PLATE,BODY 1	1	≥10001		(2WD)	0	0
013	35260-19830	NAME PLATE,BODY 1	1	≥10001		(2WD)	0.015	0.033
013	35290-19830	NAME PLATE,BODY 1	1	≥10001		(4WD)	0	0
013	35260-19830	NAME PLATE,BODY 1	1	≥10001		(4WD)	0.015	0.033
014	34152-57920	RIVET	4				0.001	0.0022
015	15222-93450	LABEL,AIR CLEANER	1				0.001	0.0022
016	19271-87210	LABEL,INSTRUCTION	1				0.001	0.0022
017	35260-25050	LABEL	1	≥10575		(2WD)	0.01	0.022
017	35260-25050	LABEL	1	≥10552		(4WD)	0.01	0.022
018	35260-29780	LABEL,ROPS	1	≥10575		(2WD)	0	0
018	35260-29780	LABEL,ROPS	1	≥10552		(4WD)	0	0

DIFFERENTIAL CASE [4WD (INTEGRAL POWER STEERING)]

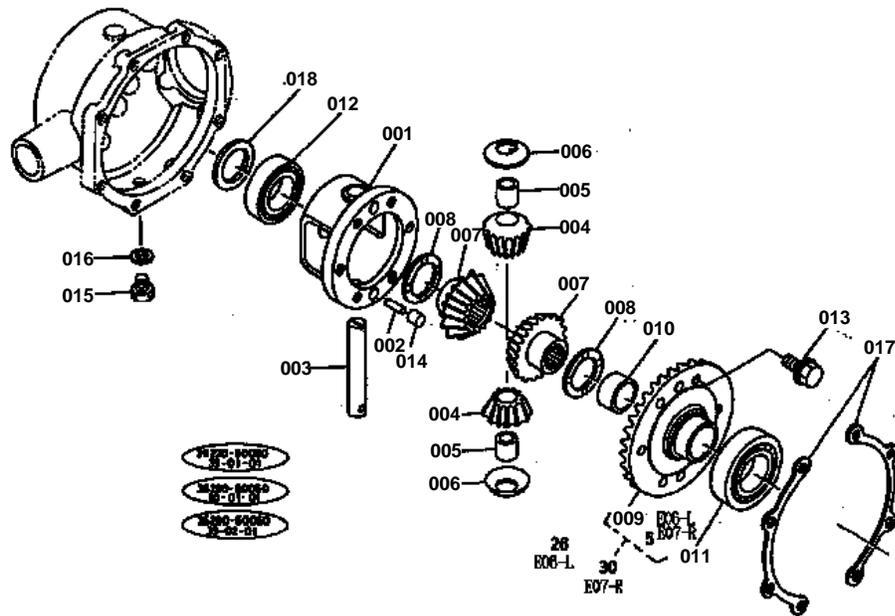

**DIFFERENTIAL CASE [4WD (INTEGRAL POWER STEERING)]**

↔ Interchangeable; ≠ not interchangeable; ← new for old; → old for new

REF.No	Part No.	Description	Q'ty	S.No.	I/C	REMARKS	Weight (kgf)	Weight (lb)
001	38440-43310	CASE, DIFFERENTIAL	1				2.1	4.62
002	37650-43320	PIN,SNAP	1				0.01	0.022
003	37650-43330	SHAFT,DIFF PINION	1				0.3	0.66
004	31220-26300	PINION, DIFFERENTIAL	2				0.155	0.341
005	31220-26360	BUSH	2				0.015	0.033
006	31220-26390	WASHER,DIFF PINION	2				0	0
007	38440-44980	GEAR,DIFF SIDE RH	2				0	0
008	31220-26480	WASHER	2				0.015	0.033
008	31220-26490	WASHER	2				0.02	0.044
008	37150-26480	WASHER	2				0.016	0.0352
009	99999-99999	BLANK	1			ORDER BY REF.No.026 ON FIG.No.093,REF.No	0	0
010	37650-43360	BUSH	1				0.039	0.0858
011	08101-06011	BEARING,BALL	1				0.376	0.8272
012	08101-06010	BEARING,BALL	1				0.262	0.5764
013	37800-43870	BOLT	6				0.026	0.0572
014	38440-43880	PIN,STRAIGHT	2				0	0
015	06331-35012	PLUG	1				0.022	0.0484
016	04717-01200	WASHER,SEAL	1				0.002	0.0044
017	37650-43130	SHIM 0.2	4				0.005	0.011
017	37650-43160	SHIM 0.1	4				0.002	0.0044
018	37650-43140	SHIM 0.2	2				0.005	0.011
018	37650-43170	SHIM 0.1	2				0.004	0.0088

BEVEL GEAR CASE [4WD (INTEGRAL POWER STEERING)]

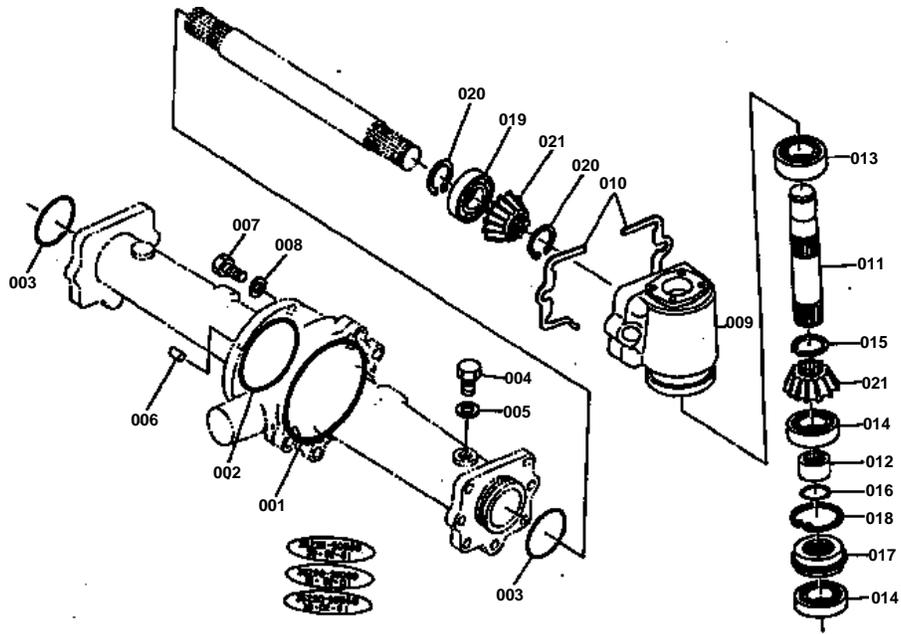

**BEVEL GEAR CASE [4WD (INTEGRAL POWER STEERING)]**

↔ Interchangeable; ≠ not interchangeable; ← new for old; → old for new

REF.No	Part No.	Description	Q'ty	S.No.	I/C	REMARKS	Weight (kgf)	Weight (lb)
001	34160-43440	O RING	1				0.005	0.011
002	04811-51300	O RING	1				0.004	0.0088
003	04811-50750	O RING	2				0.002	0.0044
004	06331-35020	PLUG	2				0.068	0.1496
005	04717-02000	WASHER,SEAL	2				0.004	0.0088
006	05012-01020	PIN,STRAIGHT	2				0.02	0.044
007	35250-43400	BOLT	8				0.025	0.055
008	04512-50100	WASHER,SPRING	8				0	0
009	38380-43440	CASE,BEVEL GEAR	2				2.9	6.38
010	37650-43450	SHIM 0.2	8				0.005	0.011
010	37650-43560	SHIM 0.1	8				0.005	0.011
011	38440-43462	SHAFT,BEVEL GEAR	2				0	0
012	38440-43480	COLLAR,SEAL	2				0.09	0.198
013	08101-06204	BEARING,BALL	2				0.102	0.2244
014	38450-25370	BEARING,BALL	4				0.2	0.44
015	04612-00300	CIR-CLIP,EXTERNAL	2				0.003	0.0066
016	04811-50300	O RING	2				0.001	0.0022
017	35290-43490	SEAL,OIL	2				0.09	0.198
018	04611-00620	CIR-CLIP,INTERNAL	2				0.011	0.0242
019	38450-25370	BEARING,BALL	2				0.2	0.44
020	04612-00300	CIR-CLIP,EXTERNAL	4				0.003	0.0066
021	37720-43820	GEAR,STR BEVEL 14	4				0.45	0.99

AXLE CASE [4WD (INTEGRAL POWER STEERING)]

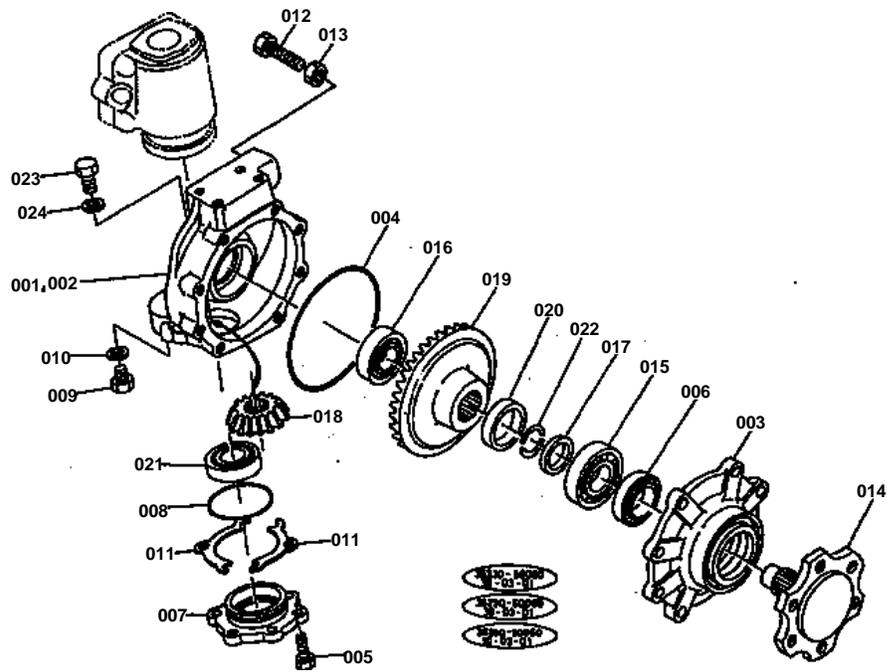

**AXLE CASE [4WD (INTEGRAL POWER STEERING)]**

↔ Interchangeable; ≠ not interchangeable; ← new for old; → old for new

REF.No	Part No.	Description	Q'ty	S.No.	I/C	REMARKS	Weight (kgf)	Weight (lb)
001	38380-43513	CASE,AXLE LH	1				7.2	15.84
002	38380-43543	CASE,AXLE RH	1				6	13.2
003	37720-43520	FLANGE,AXLE	2				2.5	5.5
004	37720-43550	O RING	2				0.01	0.022
005	01123-50822	BOLT	12				0.012	0.0264
006	37650-43530	SEAL,OIL	2				0.062	0.1364
007	37650-43580	CASE,BEARING	2				0.88	1.936
008	04811-50900	O RING	2				0.003	0.0066
009	06331-35012	PLUG	2				0.022	0.0484
010	04717-01200	WASHER,SEAL	2				0.002	0.0044
011	37650-43590	SHIM 0.2	16				0.002	0.0044
011	37650-43570	SHIM 0.1	4				0.004	0.0088
012	01175-51450	BOLT	2				0.072	0.1584
013	02176-50140	NUT	2				0.014	0.0308
014	35290-43610	AXLE	2				3.7	8.14
015	08101-06207	BEARING,BALL	2				0.282	0.6204
016	08101-06206	BEARING,BALL	2				0.196	0.4312
017	37650-43670	COLLAR,THRUST	2				0.01	0.022
018	37720-43650	GEAR,STR BEVEL 17	2				0.5	1.1
019	37720-43660	GEAR,STR BEVEL 38	2				2.7	5.94
020	37720-43690	COLLAR	2				0.038	0.0836
021	08101-06008	BEARING,BALL	2				0.19	0.418
022	37650-43680	RING	4				0	0
023	06331-35020	PLUG	2				0.068	0.1496
024	04717-02000	WASHER,SEAL	2				0.004	0.0088

KNUCKLE ARM [4WD (INTEGRAL POWER STEERING)]

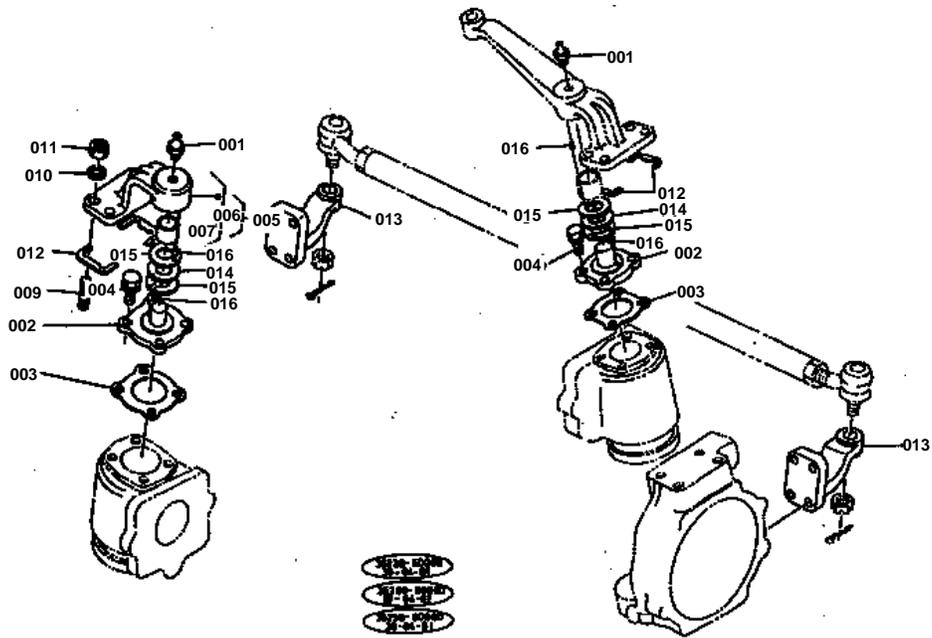



KNUCKLE ARM [4WD (INTEGRAL POWER STEERING)]

↔ Interchangeable; ≠ not interchangeable; ← new for old; → old for new

REF.No	Part No.	Description	Q'ty	S.No.	I/C	REMARKS	Weight (kgf)	Weight (lb)
001	06613-10010	NIPPLE,GREASE	2				0.006	0.0132
002	35290-43920	PIN,KNUCKLE	2				0.65	1.43
003	38380-43980	GASKET	2				0.003	0.0066
004	01123-50822	BOLT	8				0.012	0.0264
005	35290-44060	ASSY SUPPORT,KNUCKLE	1				0	0
006	35290-43900	SUPPORT,KNUCKLE RH	1				1.29	2.838
007	35290-43890	BUSH	1				0.03	0.066
008	99999-99999	BLANK	0				0	0
009	01517-51028	STUD	4				0.022	0.0484
010	04512-50100	WASHER,SPRING	4				0	0
011	37300-14190	NUT	4				0.009	0.0198
012	37650-43860	SHIM 0.2	20				0.001	0.0022
013	38380-43940	ARM,KNUCKLE	2				0.765	1.683
014	35290-43870	WASHER	2				0.17	0.374
015	35290-43880	WASHER	4				0.03	0.066
016	05012-00408	PIN,SPLIT	4				0.001	0.0022

DRAG LINK [4WD (INTEGRAL POWER STEERING)]

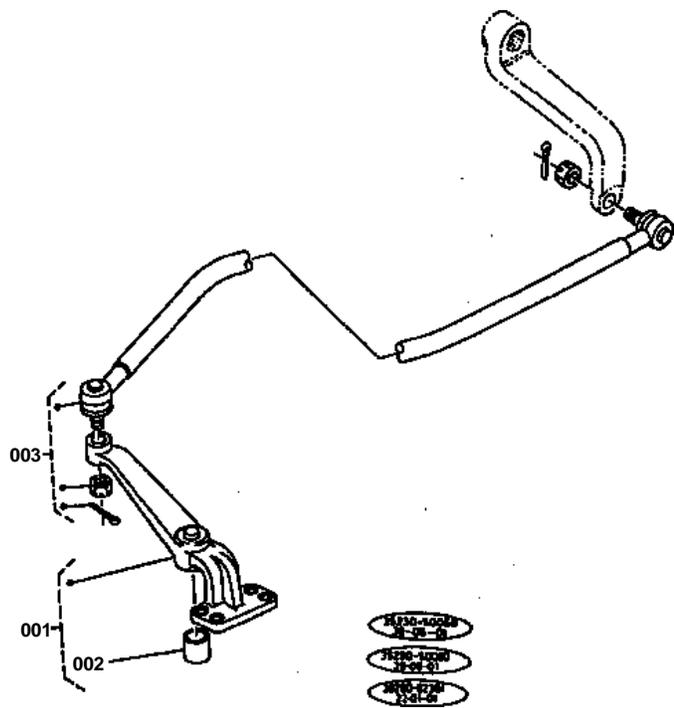



DRAG LINK [4WD (INTEGRAL POWER STEERING)]

↔ Interchangeable; ≠ not interchangeable; ← new for old; → old for new

REF.No	Part No.	Description	Q'ty	S.No.	I/C	REMARKS	Weight (kgf)	Weight (lb)
001	99999-99999	BLANK	1			ORDER BY REF.No.003	0	0
002	35290-43890	BUSH	1				0.03	0.066
003	35230-43980	ASSY LINK,DRAG	1			L235(4WD)	2.8	6.16
003	35290-43980	ASSY LINK,DRAG	1			L275(4WD)	3	6.6

DRIVE CASE [4WD (INTEGRAL POWER STEERING)]

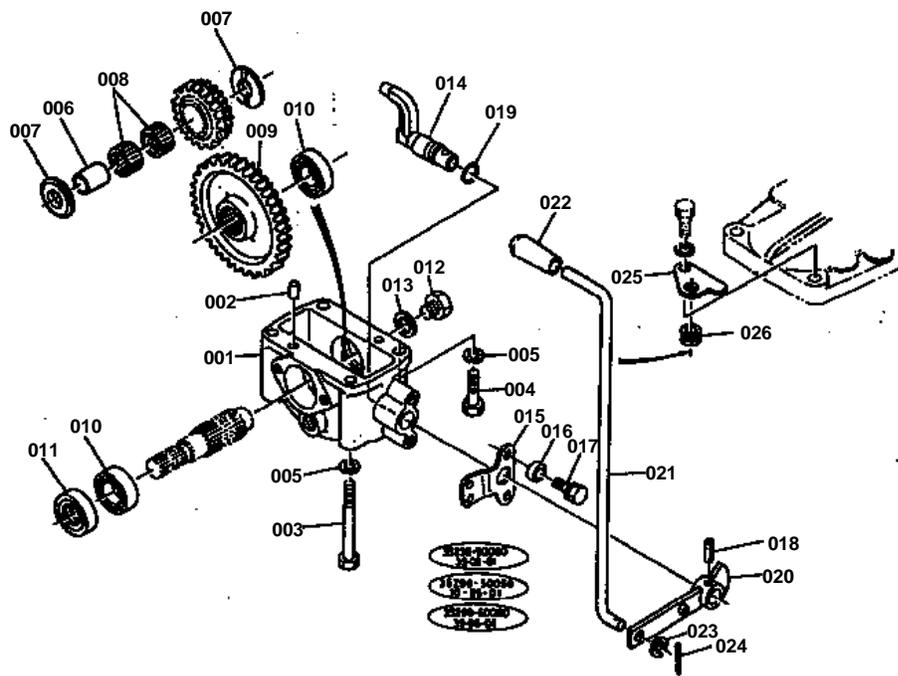

**DRIVE CASE [4WD (INTEGRAL POWER STEERING)]**

↔ Interchangeable; ≠ not interchangeable; ← new for old; → old for new

REF.No	Part No.	Description	Q'ty	S.No.	I/C	REMARKS	Weight (kgf)	Weight (lb)
001	38440-44210	CASE	1				1	2.2
002	05012-01018	PIN,STRAIGHT	2				0.012	0.0264
003	01173-51203	BOLT	2				0.106	0.2332
004	01173-51235	BOLT	2				0.04	0.088
005	04512-50120	WASHER,SPRING	4				0	0
006	37650-44170	RACE,INNER	1				0.05	0.11
007	38240-21760	COLLAR,THRUST	2				0.02	0.044
008	08823-03614	BEARING,NEEDLE	2				0.022	0.0484
009	38440-44230	GEAR,45	1				1.3	2.86
010	08101-06205	BEARING,BALL	2				0.14	0.308
011	38440-44240	SEAL,OIL	1				0.027	0.0594
012	06331-35012	PLUG	1				0.022	0.0484
013	04717-01200	WASHER,SEAL	1				0.002	0.0044
014	38440-44310	LEVER,SHIFT	1				0.15	0.33
015	38440-44350	GUIDE,LEVER	1				0.055	0.121
016	35290-44390	COLLAR	2				0.015	0.033
017	01120-50825	BOLT	2				0	0
018	05411-00625	PIN,SPRING	1				0.004	0.0088
019	04811-00150	O RING	1				0.001	0.0022
020	35290-44360	LEVER,CHANGE	1				0.225	0.495
021	35290-44370	LEVER,CHANGE	1				0.495	1.089
022	06914-00120	GRIP,LEVER	1				0.018	0.0396
023	04011-50120	WASHER,PLAIN	1				0.005	0.011
024	05511-50425	PIN,SPLIT	1				0.003	0.0066
025	35290-44380	SUPPORT,LEVER	1				0.065	0.143
026	37800-44390	RUBBER,GUIDE	1				0.005	0.011

FRONT AXLE BRACKET [4WD (INTEGRAL POWER STEERING)]

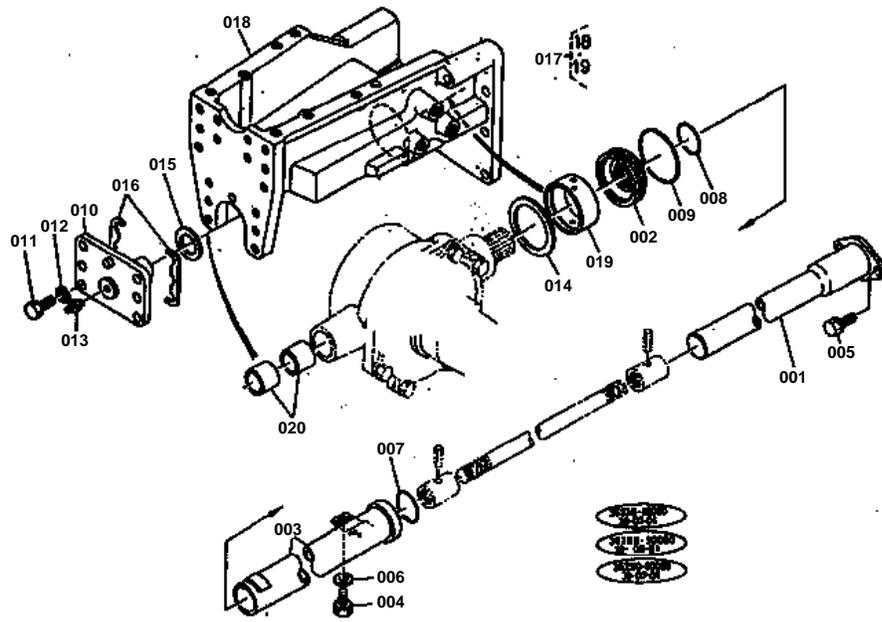

**FRONT AXLE BRACKET [4WD (INTEGRAL POWER STEERING)]**

↔ Interchangeable; ≠ not interchangeable; ← new for old; → old for new

REF.No	Part No.	Description	Q'ty	S.No.	I/C	REMARKS	Weight (kgf)	Weight (lb)
001	35290-44570	COVER 1	1				1.13	2.486
002	37650-44580	COVER,SEAL	1				0.22	0.484
003	35290-44590	COVER 2	1				0.54	1.188
004	01130-51020	BOLT	1				0	0
005	01120-50822	BOLT	2				0	0
006	04013-50100	WASHER,PLAIN	1				0	0
007	04811-00340	O RING	1				0.002	0.0044
008	04811-00380	O RING	1				0.003	0.0066
009	04811-50650	O RING	1				0.002	0.0044
010	37650-44610	PIN,CENTER	1				0.99	2.178
011	01173-51025	BOLT	6				0.021	0.0462
012	04512-50100	WASHER,SPRING	6				0	0
013	06613-10675	NIPPLE,GREASE	2				0.003	0.0066
014	37650-44640	COLLAR,THRUST	1				0.04	0.088
015	37650-44670	COLLAR,THRUST	1				0.03	0.066
016	37650-44650	SHIM 1	2				0.01	0.022
016	37650-44660	SHIM 0.2	20				0.001	0.0022
017	35250-44700	ASSY BRACKET,FRONT A	1				0	0
018	35250-44710	BRACKET,FRONT AXLE	1				0	0
019	37650-44620	BUSH	1				0.09	0.198
020	37650-44630	BUSH	2				0.05	0.11