

# Instructions for Parts Books

The heading at the top of the page will be the same for the picture of the parts as it is for the page with the part numbers.

Definition of column headings on part number pages:

**REF.No** → The number referring to the part on the picture page of the parts book.

**Part No.** → The number assigned to this part at the time of printing the parts book.

**Description** → Description of part.

**Q'ty** → Quantity of part used on that page.

**S.No.** → Serial number range of the equipment that this part will fit.

>= Your serial number should be greater than or equal to the number shown.

<= Your serial number should be lesser than or equal to the serial number shown.

**I/C** → Interchangeability of part shown.

↔ The part shown will work for the older and later serial number.

# The part shown is not interchangeable with the other serial number.

← new for old

→ old for new

**Remarks** → Notes about this particular part. Sometimes this may say except [FR] or [CA]

## Note about Country Codes:

The parts books we use in the United States of America may also contain information about a part that would be different in another country. It is important that you are aware of the country codes in some instances.

Symbol	Country
A	United States of America
CA	Canada
FR	France
GR	Greece
PO	Portugal
AU	Australia

If the remarks column says for example EXCEPT [FR] this part works in all countries except France. That means it will work here in the USA.

ALL PRODUCT INDEX  
L305F

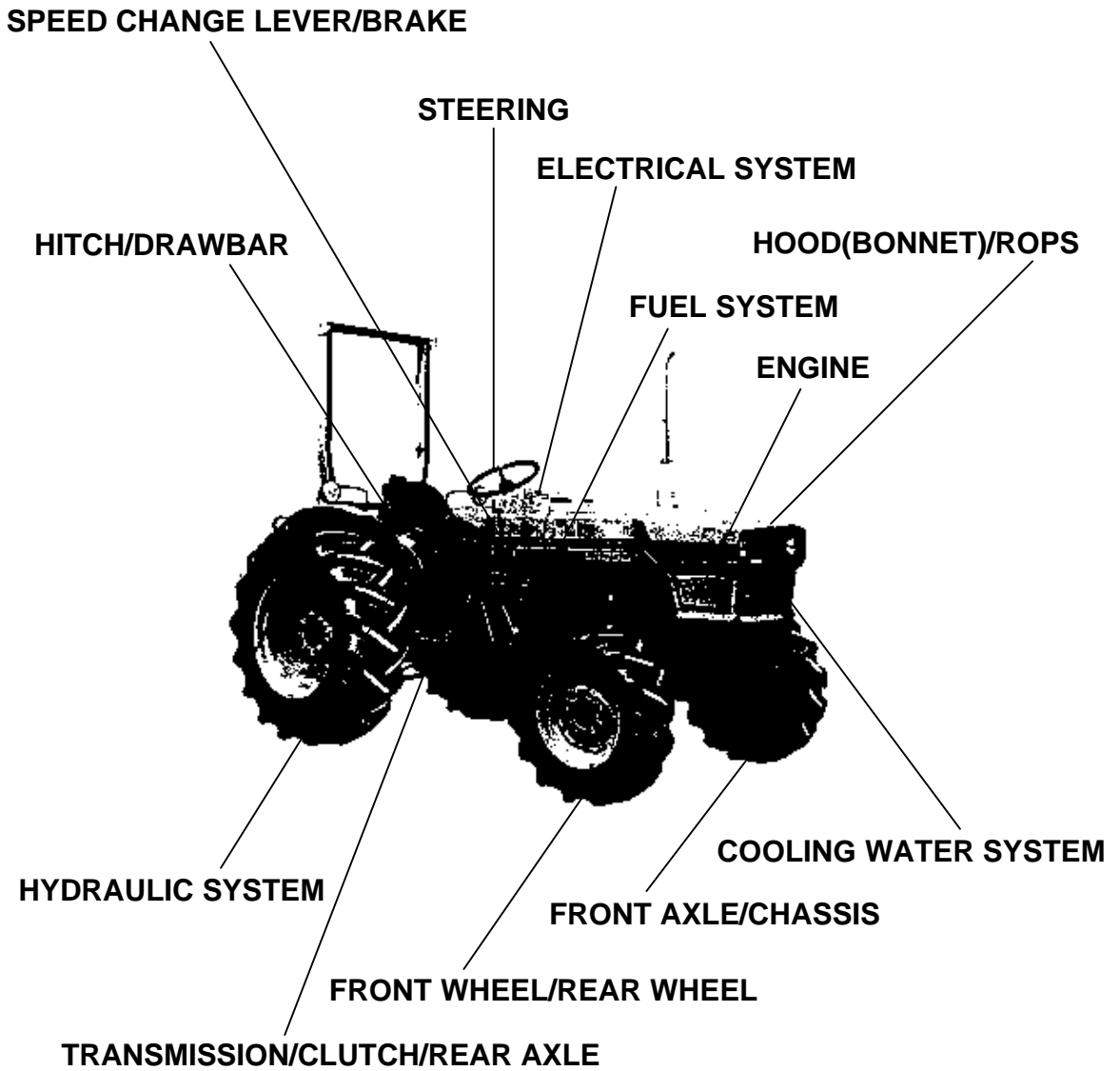

LABELS  
ACCESSORIES  
SERVICE PARTS  
SECTION PARTS

Item	Part No.	Description	Book
ENGINE	01T001	CRANKCASE	100K0628
	01T002	CYLINDER HEAD	100K0628
	01T003	GEAR CASE	100K0628
	01T004	MAIN BEARING CASE	100K0628
	01T005	BREATHER	100K0628
	01T00601	AIR CLEANER	100K0628
	01T00602	AIR CLEANER DOUBLE (OPTION)	100K0628
	01T007	MUFFLER	100K0628
	01T008	VALVE ROCKER ARM	100K0628
	01T009	HEAD COVER	100K0628
	01T010	CAMSHAFT	100K0628
	01T011	PISTON CRANKSHAFT	100K0628
	01T012	FLYWHEEL	100K0628
	01T013	NOZZLE HOLDER	100K0628
	01T014	FUEL CAMSHAFT	100K0628
	01T015	SPEED CONTROL PLATE	100K0628
	COOLING WATER SYSTEM	01T016	GOVERNOR
01T017		DYNAMO	100K0628
SECTION PARTS	01T018	RADIATOR	100K0628
	01T019	WATER PUMP	100K0628
FRONT AXLE/CHASSIS	01T068	OIL FILTER 2	100K0628
	01T069	STARTER	100K0628
	01T070	NOZZLE HOLDER 2	100K0628
	01T071	DYNAMO	100K0628
	01T072	INJECTION PUMP	100K0628
ELECTRICAL SYSTEM	01T020	FRONT WHEEL	100K0628
	01T021	STEERING LINKAGE	100K0628
	01T022	FRONT AXLE BRACKET	100K0628
TRANSMISSION/CLUTCH/REAR AXLE	01T023	BATTERY	100K0628
	01T024	FLYWHEEL HOUSING	100K0628
STEERING	01T025	CLUTCH HOUSING	100K0628
	01T026	CLUTCH	100K0628
	01T027	CLUTCH PEDAL	100K0628
	01T028	STEERING	100K0628
	01T029	HAND ACCEL	100K0628
	01T030	HOOD	100K0628
	01T031	HEAD LAMP	100K0628
	01T032	SEAT	100K0628
	01T033	TRANSMISSION CASE	100K0628
	01T034	TRANSMISSION 1	100K0628
SPEED CHANGE LEVER/BRAKE	01T035	TRANSMISSION 2	100K0628
	01T036	TRANSMISSION 3	100K0628
	01T037	SPEED CHANGE SYSTEM 1	100K0628
	01T038	SPEED CHANGE SYSTEM 2	100K0628
	01T039	SPEED CHANGE SYSTEM 3	100K0628
	01T040	DIFFERENTIAL SYSTEM 1	100K0628
	01T041	DIFFERENTIAL SYSTEM 2	100K0628
	01T042	REAR AXLE	100K0628
	01T043	AXLE CASE	100K0628
	01T044	BRAKE	100K0628
	01T045	BRAKE PEDAL	100K0628
HOOD(BONNET)/ROPS	01T046	FENDER	100K0628
	01T047	ELECTRICAL 1	100K0628
ELECTRICAL SYSTEM	01T048	ELECTRICAL 2	100K0628
	01T049	ELECTRICAL 3	100K0628
	01T050	FUEL TANK	100K0628
FUEL SYSTEM	01T051	FUEL FILTER	100K0628
	01T052	OIL PRESSURE 1	100K0628
HYDRAULIC SYSTEM	01T053	OIL PRESSURE 2	100K0628
	01T054	O/P CYLINDER	100K0628

Item	Part No.	Description	Book
HYDRAULIC SYSTEM	01T055	O/P LIFT ARM SYSTEM	100K0628
	01T056	TOP LINK BRACKET	100K0628
LABELS	01T057	LABEL	100K0628
HYDRAULIC SYSTEM	01T058	FLOW PRIORITY VALVE	100K0628
HITCH/DRAWBAR	01T059	3-POINT LINKAGE	100K0628
ELECTRICAL SYSTEM	01T060	HAZARD LAMP (OPTION)	100K0628
SECTION PARTS	01T073	CONTROL VALVE	100K0628
	01T074	DRAFT CONTROL VALVE	100K0628
	01T075	OIL PRESSURE PUMP	100K0628
	01T076	INTEGRAL TYPE POWER STEERING	100K0628
ACCESSORIES	01T077	ACCESSORY AND SERVICE PARTS	100K0628
SERVICE PARTS	01T078	TRANSMISSION CASE (SERVICE PARTS)	100K0628
	01T079	TRANSMISSION 3 (SERVICE PARTS)	100K0628
	01T080	ACCESSARY AND SERVICE PARTS (DOUBLE ACTING X 1)	100K0628
	01T081	ACCESSARY AND SERVICE PARTS (DOUBLE ACTING X 2)	100K0628

# CRANKCASE

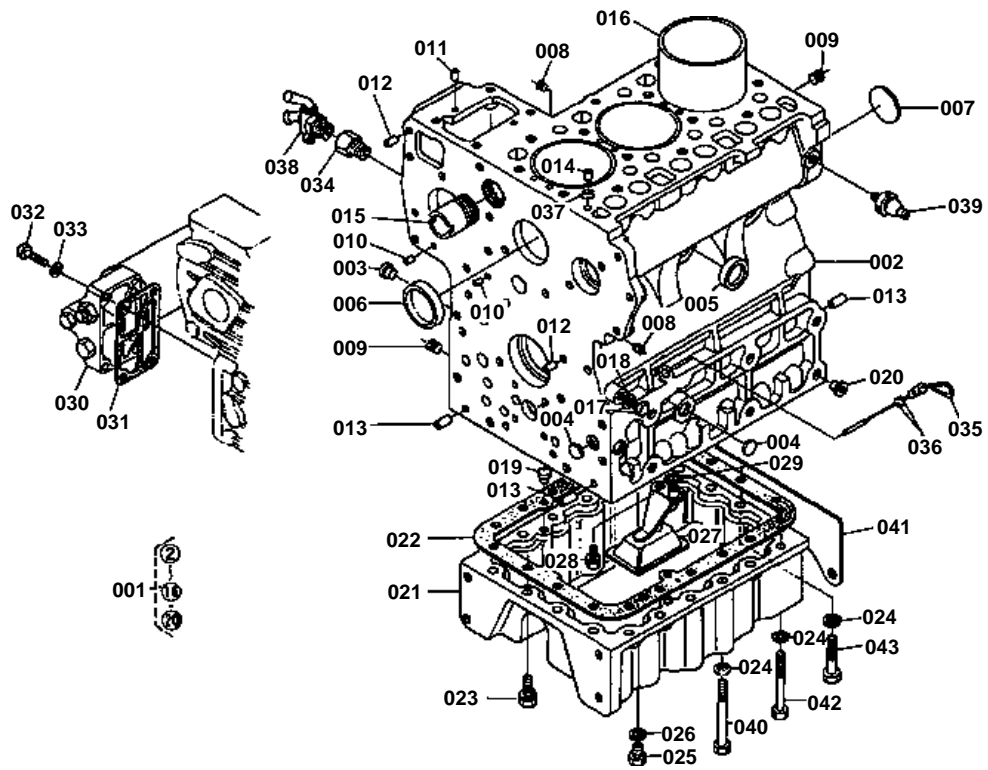



# CRANKCASE

↔ Interchangeable; ≠ not interchangeable; ← new for old; → old for new

REF.No	Part No.	Description	Q'ty	S.No.	I/C	REMARKS	Weight (kgf)	Weight (lb)
001	15301-01012	ASSY CRANKCASE	1				50	110
002	99999-99999	BLANK	0			ORDER BY REF.No.001	0	0
003	34150-27580	PLUG	1				0.001	0.0022
004	06311-75015	PLUG EXPANSION	3				0.002	0.0044
005	15221-03380	CAP SEALING	5				0.017	0.0374
006	15221-03390	CAP SEALING	2				0.03	0.066
007	06311-75045	PLUG EXPANSION	1				0.026	0.0572
008	15521-96020	PLUG	5				0.003	0.0066
009	15521-96030	PLUG	2				0.007	0.0154
010	05012-00408	PIN STRAIGHT	2				0.001	0.0022
011	05012-00609	PIN STRAIGHT	2				0.003	0.0066
012	05012-00612	PIN STRAIGHT	2				0.003	0.0066
013	05012-01018	PIN STRAIGHT	3				0.012	0.0264
014	15221-33650	PIN PIPE	1				0.004	0.0088
015	15221-72840	PIPE WATER	1				0.078	0.1716
016	15201-02310	LINER CYLINDER	3				0.57	1.254
017	15221-33610	PLUG	1				0.009	0.0198
018	15021-33660	GASKET	1				0.001	0.0022
019	15411-94510	PIN	2				0.01	0.022
020	32210-27580	PLUG	9				0.001	0.0022
021	15357-01610	OIL PAN	1				13	28.6
022	15301-01620	GASKET OIL PAN	1				0	0
023	01133-51035	BOLT	12				0.03	0.066
024	04512-50100	WASHER SPRING	8				0	0
025	15221-33750	PLUG	2				0.032	0.0704
026	15109-33660	GASKET	2				0.001	0.0022
027	15301-32110	FILTER OIL	1				0.23	0.506
028	01123-50816	BOLT	1				0.011	0.0242
029	04811-00140	O RING	1				0.001	0.0022
030	15213-32020	ASSY FILTER OIL 2	1				0.89	1.958
031	15213-32320	GASKET	1				0	0
032	01153-50842	BOLT	4				0.018	0.0396
033	04512-50080	WASHER SPRING	4				0	0
034	15291-73160	JOINT DRAIN COCK	1				0.04	0.088
035	15221-36410	GAUGE OIL	1				0.028	0.0616
036	04811-00050	O RING	2				0.001	0.0022
037	15221-33700	O RING	1				0.001	0.0022
038	14412-73110	ASSY COCK DRAIN	1				0.09	0.198
039	15221-39010	SWITCH OIL	1				0	0
040	15411-91010	BOLT	4				0	0
041	15415-04690	SHIM	1				0.03	0.066
042	15415-91010	BOLT	2				0.075	0.165
043	01173-51050	BOLT	2				0.035	0.077

CYLINDER HEAD

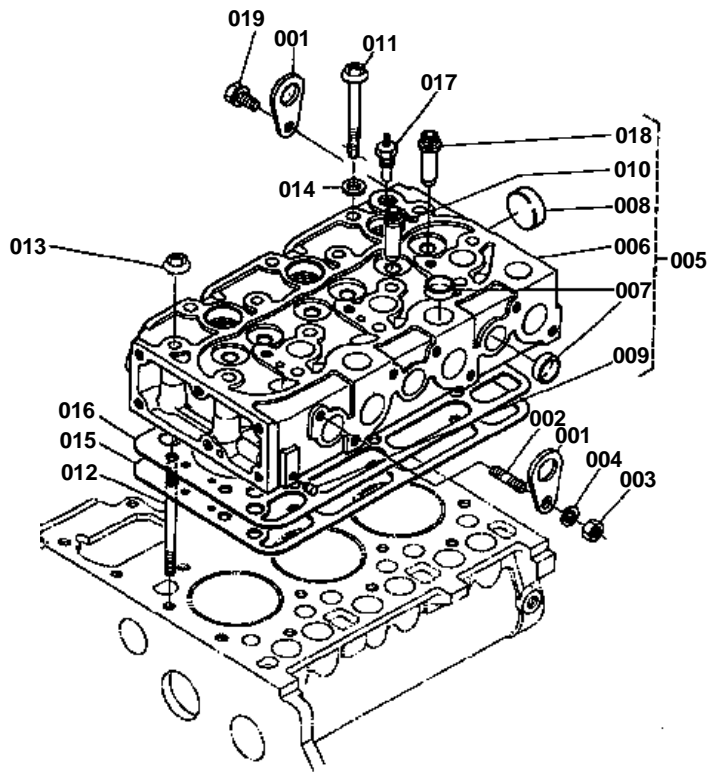

REF. No. 15221-0345-0

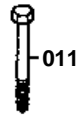

① 15221-0341-0  
② 15221-0351-0

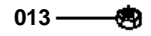

③ 15221-0354-0

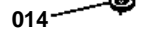

Discontinance.



# CYLINDER HEAD

↔ Interchangeable; ≠ not interchangeable; ← new for old; → old for new

REF.No	Part No.	Description	Q'ty	S.No.	I/C	REMARKS	Weight (kgf)	Weight (lb)
001	15221-01750	HOOK ENGINE	2				0.04	0.088
002	15521-91490	STUD	1				0	0
003	02056-50080	NUT	1				0.005	0.011
004	04512-50080	WASHER SPRING	1				0	0
005	15301-03040	ASSY CYLINDER HEAD	1				15.1	33.22
006	99999-99999	BLANK	0			ORDER BY REF.No.005	0	0
007	15221-03370	CAP SEALING	9				0.01	0.022
008	15221-03490	CAP SEALING	1				0.02	0.044
009	15261-96010	PLUG	2				0.002	0.0044
010	15221-13580	GUIDE VALVE	3				0	0
011	15221-03450	BOLT CYLINDER HEAD	12	<=1892			0	0
011	19202-03450	BOLT CYLINDER HEAD	12	>=1893			0.065	0.143
012	15221-03410	STUD CYLINDER HEAD	2	<=1892			0	0
012	19202-03410	STUD CYLINDER HEAD	2	>=1893			0.065	0.143
013	15221-03510	NUT CYLINDER HEAD	2	<=1892			0.008	0.0176
013	19202-03510	NUT CYLINDER HEAD	2	>=1893			0.012	0.0264
014	15221-03540	WASHER PLAIN	14	<=1892			0.003	0.0066
015	15301-03310	GASKET CYLINDER HEAD	1				0	0
016	15301-03320	SHIM CYL.HEAD GASKET	1				0.06	0.132
017	33400-75250	SWITCH THERMOMETER	1				0.033	0.0726
018	15601-13560	GUIDE EXHAUST VALVE	3				0	0
019	01123-50816	BOLT	1				0.011	0.0242



# GEAR CASE

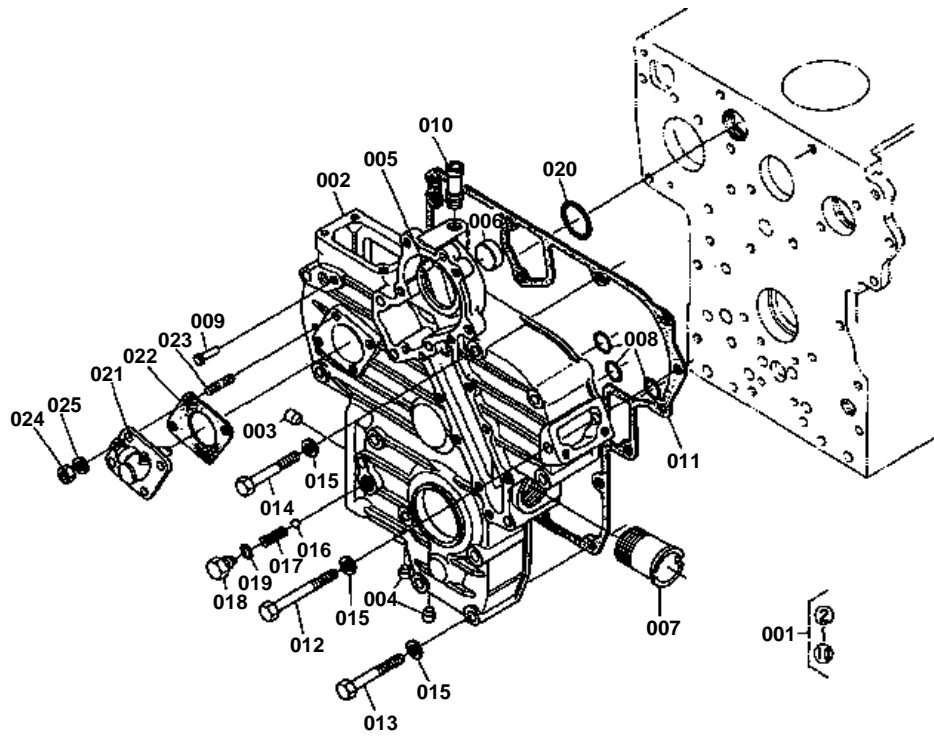

**GEAR CASE**

↔ Interchangeable; ≠ not interchangeable; ← new for old; → old for new

REF.No	Part No.	Description	Q'ty	S.No.	I/C	REMARKS	Weight (kgf)	Weight (lb)
001	15341-04020	ASSY CASE GEAR	1				4.25	9.35
002	99999-99999	BLANK	0			ORDER BY REF No.001	0	0
003	15221-33620	PLUG PIN	1				0.002	0.0044
004	15221-33660	PLUG PIN	2				0.004	0.0088
005	05012-00612	PIN STRAIGHT	2				0.003	0.0066
006	15321-96260	CAP SEALING	1				0.014	0.0308
007	15221-72880	PIPE WATER	1				0.115	0.253
008	04811-00150	O RING	3				0.001	0.0022
009	15221-56280	PIN START SPRING	1				0.006	0.0132
010	15321-73340	PIPE WATER RETURN	1				0.016	0.0352
011	15601-04130	GASKET GEAR CASE	1				0	0
012	01153-50885	BOLT	4				0.031	0.0682
013	15521-91010	BOLT	7				0	0
014	01153-50870	BOLT	4				0.026	0.0572
015	04512-50080	WASHER SPRING	15				0	0
016	07715-00803	BALL	1				0.004	0.0088
017	15221-38440	SPRING	1				0.004	0.0088
018	15221-38420	CAP	1				0.025	0.055
019	04811-00100	O RING	1				0.001	0.0022
020	04811-40240	O RING	1				0.002	0.0044
021	37150-34660	ASSY CASE GEAR HOUR	1				0.32	0.704
022	15221-88130	GASKET	1				0	0
023	15221-88210	STUD	4				0.005	0.011
024	02056-50060	NUT	4				0.002	0.0044
025	04512-50060	WASHER SPRING	4				0	0

# MAIN BEARING CASE

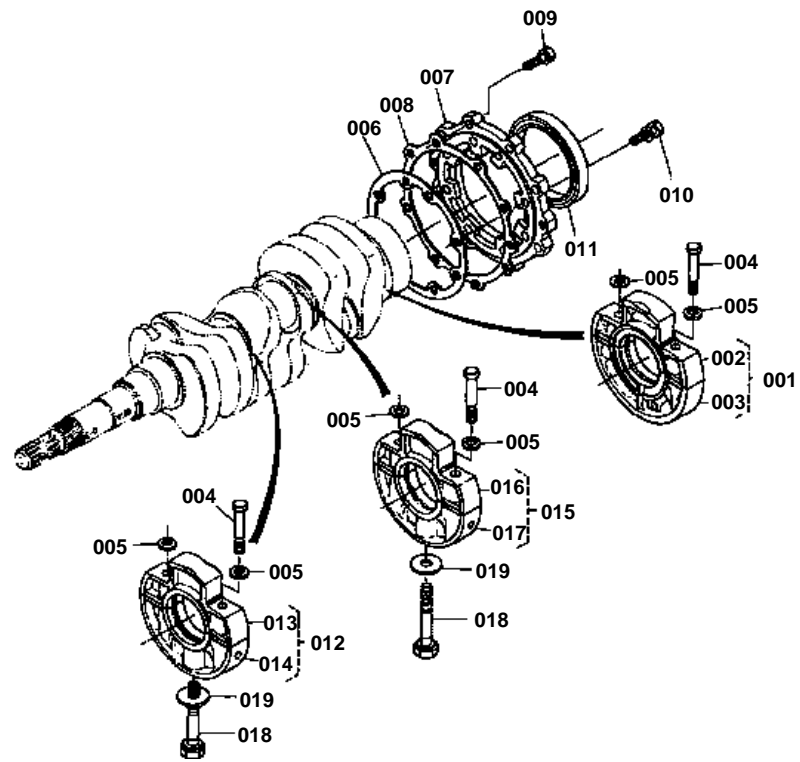



# MAIN BEARING CASE

↔ Interchangeable; ≠ not interchangeable; ← new for old; → old for new

REF.No	Part No.	Description	Q'ty	S.No.	I/C	REMARKS	Weight (kgf)	Weight (lb)
001	15521-04040	ASSY CASE MAIN BEARI	1				0	0
002	99999-99999	BLANK	0			ORDER BY REF.No.001	0	0
003	99999-99999	BLANK	0			ORDER BY REF.No.001	0	0
004	15521-04540	BOLT 1	6				0	0
005	15521-94010	WASHER	6				0.001	0.0022
006	15221-04360	GASKET	1				0	0
007	15221-04810	COVER BEARING	1				0.3	0.66
008	15221-04820	GASKET COVER	1				0	0
009	01123-50825	BOLT	8				0.013	0.0286
010	01123-50828	BOLT	8				0.014	0.0308
011	15221-04460	SEAL OIL	1				0.06	0.132
012	15521-04050	ASSY CASE BEARING 1	1				0	0
013	99999-99999	BLANK	0			ORDER BY REF.No.012	0	0
014	99999-99999	BLANK	0			ORDER BY REF.No.012	0	0
015	15521-04060	ASSY CASE MAIN BEARI	1				0	0
016	99999-99999	BLANK	0			ORDER BY REF.No.015	0	0
017	99999-99999	BLANK	0			ORDER BY REF.No.015	0	0
018	15291-04560	BOLT 2	2				0.06	0.132
019	15521-94020	WASHER	2				0.004	0.0088

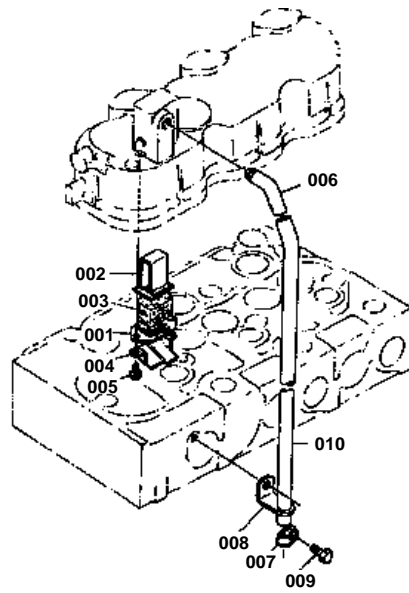



# BREATHER

↔ Interchangeable; ≠ not interchangeable; ← new for old; → old for new

REF.No	Part No.	Description	Q'ty	S.No.	I/C	REMARKS	Weight (kgf)	Weight (lb)
001	15521-05140	PLATE BREATHER ELEME	1				0.005	0.011
002	15521-05150	PLATE BREATHER ELEME	1				0.01	0.022
003	15521-05670	ELEMENT BREATHER	1				0.01	0.022
004	15521-05370	OIL SHIELD BREATHER	1				0.005	0.011
005	15521-93310	SCREW	2				0	0
006	15521-05550	JOINT BREATHER PIPE	1				0.04	0.088
007	15341-05590	CLAMP PIPE	1				0.003	0.0066
008	15401-05580	CLAMP PIPE	1				0.02	0.044
009	01173-51218	BOLT	1				0.028	0.0616
010	15401-05510	PIPE BREATHER	1				0	0

# AIR CLEANER

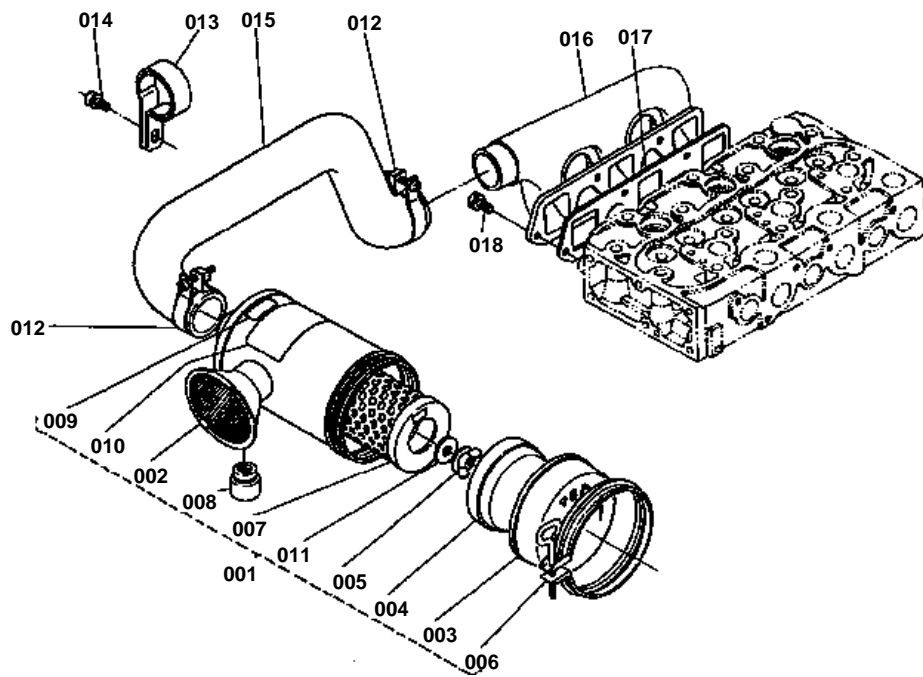

**AIR CLEANER**

↔ Interchangeable; ≠ not interchangeable; ← new for old; → old for new

REF.No	Part No.	Description	Q'ty	S.No.	I/C	REMARKS	Weight (kgf)	Weight (lb)
001	15401-11010	ASSY CLEANER AIR	1				2.9	6.38
002	15401-11150	BODY AIR CLEANER	1				1.15	2.53
003	15401-11160	COVER AIR CLEANER	1				0.38	0.836
004	15401-11410	COVER BAFFLE	1				0.05	0.11
005	15401-92620	NUT WING	1				0.01	0.022
006	15401-11070	ASSY BAND AIR CLEANER	1				0.115	0.253
007	15401-11080	ASSY ELEMENT AIR CLEANER	1				0.74	1.628
008	15401-11090	ASSY INDICATER	1				0.021	0.0462
009	15401-87750	MARK FORM	1				0.001	0.0022
010	15401-87450	LABEL AIR CLEANER	1				0.002	0.0044
011	15401-94430	WASHER SEAL	1				0.009	0.0198
012	15401-11720	BAND PIPE	2				0.05	0.11
013	15401-11700	ASSY HOLDER INLET PIPE	1				0.08	0.176
014	03004-50812	SCREW	1				0.008	0.0176
015	15301-11620	PIPE INLET	1				0.66	1.452
016	15521-11760	MANIFOLD INLET	1				0.79	1.738
017	15521-11820	GASKET IN-MANIFOLD	1				0	0
018	01123-50822	BOLT	5				0.012	0.0264



AIR CLEANER DOUBLE (OPTION)

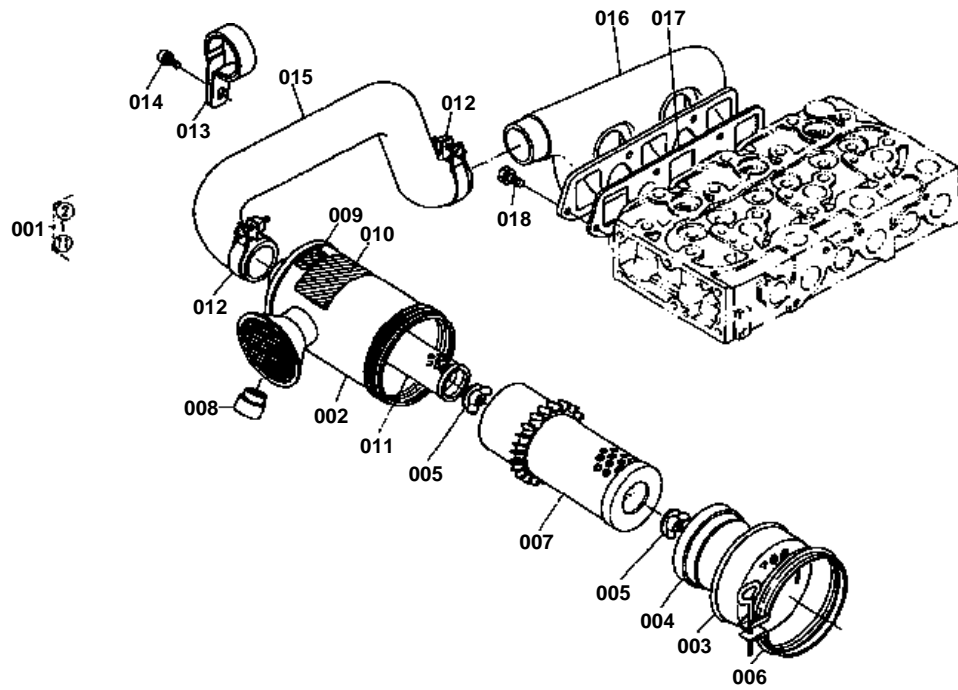



## AIR CLEANER DOUBLE (OPTION)

↔ Interchangeable; ≠ not interchangeable; ← new for old; → old for new

REF.No	Part No.	Description	Q'ty	S.No.	I/C	REMARKS	Weight (kgf)	Weight (lb)
001	15312-11010	ASSY CLEANER AIR	1				3	6.6
002	15312-11150	BODY AIR CLEANER	1				1.48	3.256
003	15401-11160	COVER CIR CLEANER	1				0.38	0.836
004	15401-11410	COVER BAFFLE	1				0.05	0.11
005	15401-92620	NUT WING	1				0.01	0.022
006	15401-11070	ASSY BAND AIR CLEANER	1				0.115	0.253
007	15287-11080	ASSY ELEMENT AIR CLEANER	1				0.75	1.65
008	15401-11090	ASSY INDICATER	1				0.021	0.0462
009	15312-87750	MARK FORM	1				0.001	0.0022
010	15287-87450	LABEL AIR CLEANER	1				0.01	0.022
011	15287-11490	ELEMENT AIR CLEANER	1				0.25	0.55
012	15401-11720	BAND PIPE	2				0.05	0.11
013	15401-11700	ASSY HOLDER INLET PIPE	1				0.08	0.176
014	03004-50812	SCREW	1				0.008	0.0176
015	15301-11620	PIPE INLET	1				0.66	1.452
016	15221-11760	MANIFOLD INLET	1				0.506	1.1132
017	15521-11820	GASKET IN-MANIFOLD	1				0	0
018	01123-50822	BOLT	5				0.012	0.0264

# MUFFLER

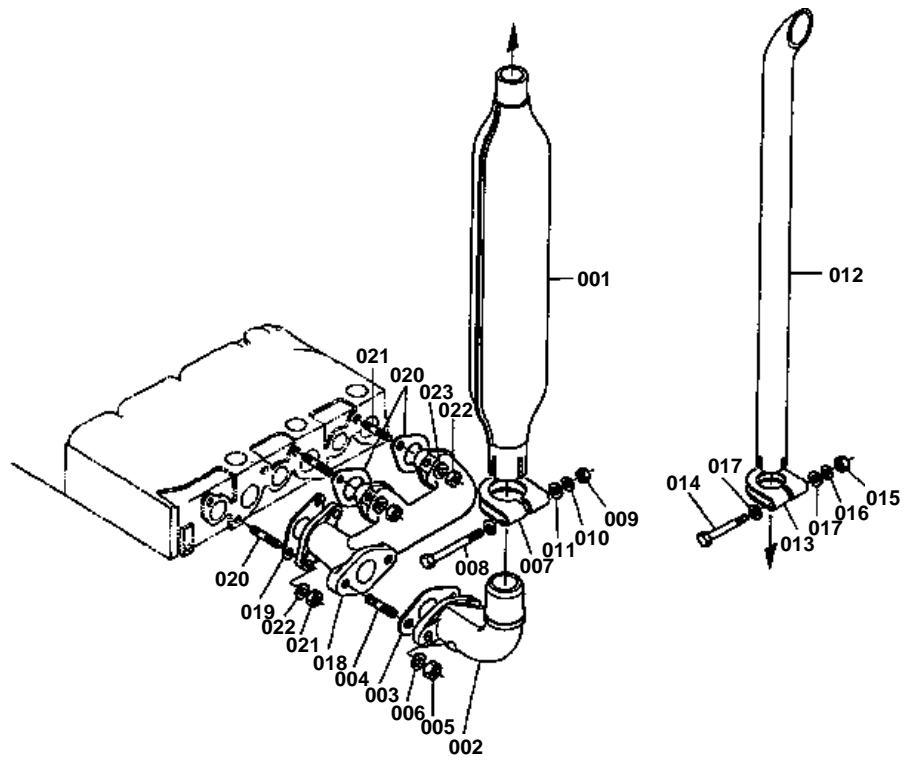

**MUFFLER**

↔ Interchangeable; ≠ not interchangeable; ← new for old; → old for new

REF.No	Part No.	Description	Q'ty	S.No.	I/C	REMARKS	Weight (kgf)	Weight (lb)
001	15221-12110	MUFFLER	1				0	0
002	15401-12320	FLANGE MUFFLER	1				0	0
003	15221-12370	GASKET M-FLANGE	1				0	0
004	15303-91560	STUD	2				0.023	0.0506
005	15021-12260	NUT	2				0.013	0.0286
006	04512-50100	WASHER SPRING	2				0	0
007	15221-12130	BAND MUFFLER	1				0	0
008	01153-50878	BOLT	1				0.029	0.0638
009	02156-50080	NUT	1				0.004	0.0088
010	04512-50080	WASHER SPRING	1				0	0
011	04012-50080	WASHER PLAIN	2				0.001	0.0022
012	34219-12410	PIPE EXHAUST	1				0.54	1.188
013	15221-12430	BAND PIPE	1				0	0
014	01153-50860	BOLT	1				0.024	0.0528
015	02156-50080	NUT	1				0.004	0.0088
016	04512-50080	WASHER SPRING	1				0	0
017	04012-50080	WASHER PLAIN	2				0.001	0.0022
018	15321-12310	MANIFOLD EXHAUST	1				1.46	3.212
019	15521-12350	GASKET EX-MANIFOLD	3				0	0
020	15221-91530	STUD	6				0.011	0.0242
021	02156-50080	NUT	6				0.004	0.0088
022	04512-50080	WASHER SPRING	6				0	0





# VALVE ROCKER ARM

↔ Interchangeable; ≠ not interchangeable; ← new for old; → old for new

REF.No	Part No.	Description	Q'ty	S.No.	I/C	REMARKS	Weight (kgf)	Weight (lb)
001	15221-13110	VALVE INLET	3				0.062	0.1364
002	15221-13120	VALVE EXHAUST	3				0.054	0.1188
003	15221-13240	SPRING VALVE	6				0.036	0.0792
004	15221-13330	RETAINER VALVE SPRIN	6				0.03	0.066
005	15221-13360	COLLET VALVE SPRING	12				0	0
006	15221-13150	SEAL VALVE STEM	6				0.001	0.0022
007	15221-13280	CAP VALVE	6				0.006	0.0132
008	15321-14050	ASSY SHAFT ROCKER AR	1				0.25	0.55
009	99999-99999	BLANK	0			ORDER BY REF.No.008	0	0
010	03410-50808	SCREW SET	2				0	0
011	15221-14350	BRACKET ROCKER ARM	3				0.044	0.0968
012	15521-91500	STUD	3				0.035	0.077
013	02156-50080	NUT	3				0.004	0.0088
014	04512-50080	WASHER SPRING	3				0	0
015	04012-50080	WASHER PLAIN	3				0.001	0.0022
016	15221-14420	SCREW SET	1				0.003	0.0066
017	15221-14430	WASHER	2				0.002	0.0044
018	15221-14310	SPRING ROCKER ARM	2				0.005	0.011
019	04612-00140	CIR-CLIP EXTERNAL	2				0.001	0.0022
020	15601-14030	ASSY ROCKER ARM	6				0	0
021	99999-99999	BLANK	0			ORDER BY REF.No.020	0	0
022	15221-14180	BUSH	6				0.007	0.0154
023	15521-14230	SCREW ADJUSTING	6				0.009	0.0198
024	15021-14240	NUT	6				0.003	0.0066

# HEAD COVER

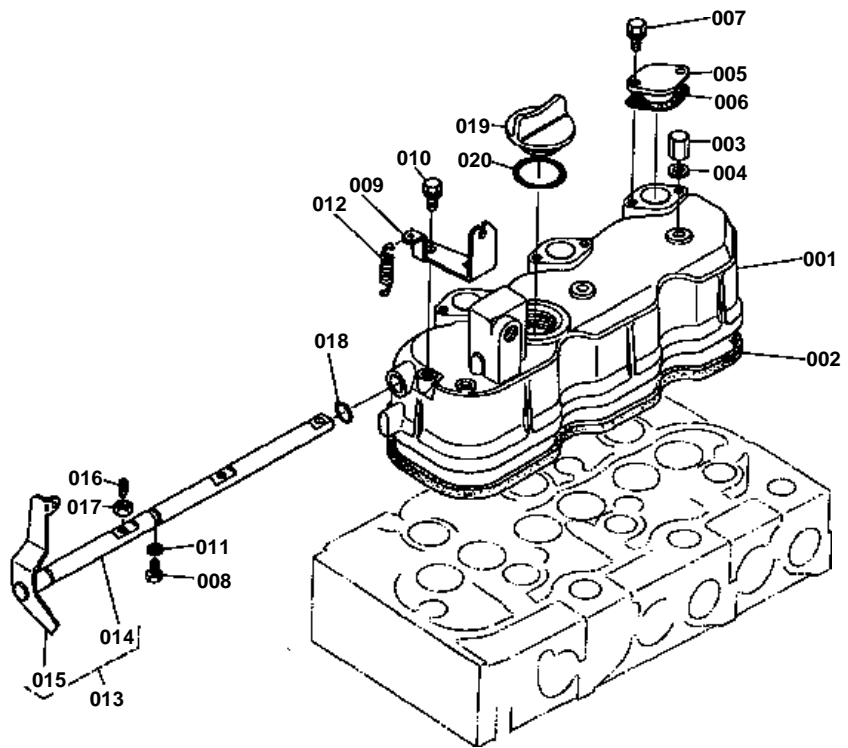



# HEAD COVER

↔ Interchangeable; ≠ not interchangeable; ← new for old; → old for new

REF.No	Part No.	Description	Q'ty	S.No.	I/C	REMARKS	Weight (kgf)	Weight (lb)
001	15521-14510	COVER HEAD	1				1.22	2.684
002	15521-14520	GASKET HEAD COVER	1				0.035	0.077
003	15451-92330	NUT CAP	3				0.015	0.033
004	15021-33660	GASKET	3				0.001	0.0022
005	15221-66630	COVER DECOMP.HOLE	3				0.035	0.077
006	15221-66640	GASKET COVER	3				0	0
007	01023-50614	BOLT	6				0.005	0.011
008	15221-66410	BOLT	1				0.005	0.011
009	15221-66190	HOLDER DECOMP.WIRE	1				0.055	0.121
010	01023-50614	BOLT	2				0.005	0.011
011	04512-50060	WASHER SPRING	1				0	0
012	15221-66280	SPRING DECOMPRESS	1				0.008	0.0176
013	15521-66040	ASSY SHAFT DECOMPRES	1				0.385	0.847
014	99999-99999	BLANK	0			ORDER BY REF.No.016	0	0
015	99999-99999	BLANK	0			ORDER BY REF.No.016	0	0
016	15221-66350	BOLT DECOMPRESS	3				0.005	0.011
017	15221-66360	NUT DECOMPRESS	1				0.003	0.0066
018	04811-06100	O RING	1				0.001	0.0022
019	15221-33140	PLUG OIL FILLER	1				0.038	0.0836
020	04811-50300	O RING	1				0.001	0.0022



# CAMSHAFT

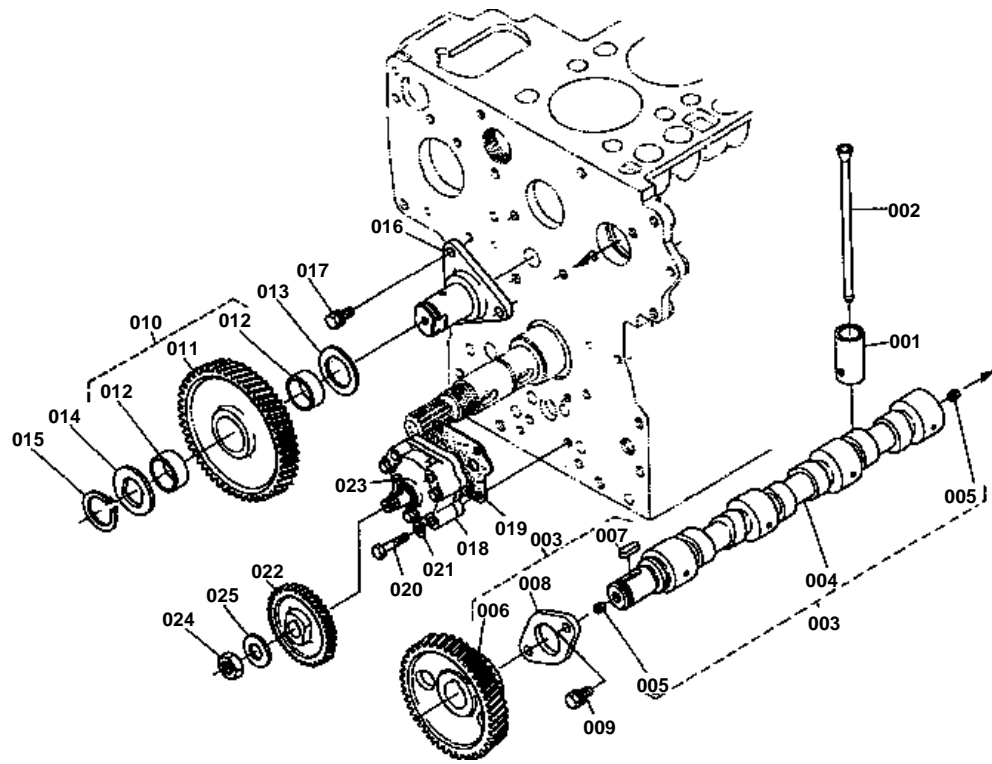

**CAMSHAFT**

↔ Interchangeable; ≠ not interchangeable; ← new for old; → old for new

REF.No	Part No.	Description	Q'ty	S.No.	I/C	REMARKS	Weight (kgf)	Weight (lb)
001	15221-15550	TAPPET	6				0	0
002	15221-15110	ROD PUSH	6				0.05	0.11
003	15521-16010	ASSY CAMSHAFT	1				3.6	7.92
004	15521-16150	CAMSHAFT	1				1.79	3.938
005	15521-93610	SCREW SET	2				0.002	0.0044
006	15521-16510	GEAR CAMSHAFT	1				0.85	1.87
007	05712-00720	KEY FEATHER	1				0.008	0.0176
008	15221-16270	STOPPER CAMSHAFT	1				0.073	0.1606
009	01123-50818	BOLT	2				0.012	0.0264
010	15221-24010	ASSY GEAR IDLE	1				0.5	1.1
011	99999-99999	BLANK	0			ORDER BY REF.No.012	0	0
012	15221-24980	BUSH IDLE GEAR	2				0.02	0.044
013	15521-24360	COLLAR 1	1				0.015	0.033
014	15521-24370	COLLAR 2	1				0.015	0.033
015	15221-24320	CIR-CLIP IDLE GEAR	1				0.01	0.022
016	15221-24250	SHAFT IDLE GEAR	1				0.48	1.056
017	01123-50818	BOLT	3				0.012	0.0264
018	15321-35010	ASSY PUMP OIL	1				0.525	1.155
019	15221-35150	GASKET OIL PUMP	1				0	0
020	01053-50648	BOLT	4				0.01	0.022
021	04512-50060	WASHER SPRING	4				0	0
022	15521-35660	GEAR OIL PUMP DRIVE	1				0	0
023	05712-00410	KEY FEATHER	1				0.001	0.0022
024	15221-35680	NUT	1				0	0
025	15221-35670	WASHER	1				0.005	0.011

# PISTON CRANKSHAFT

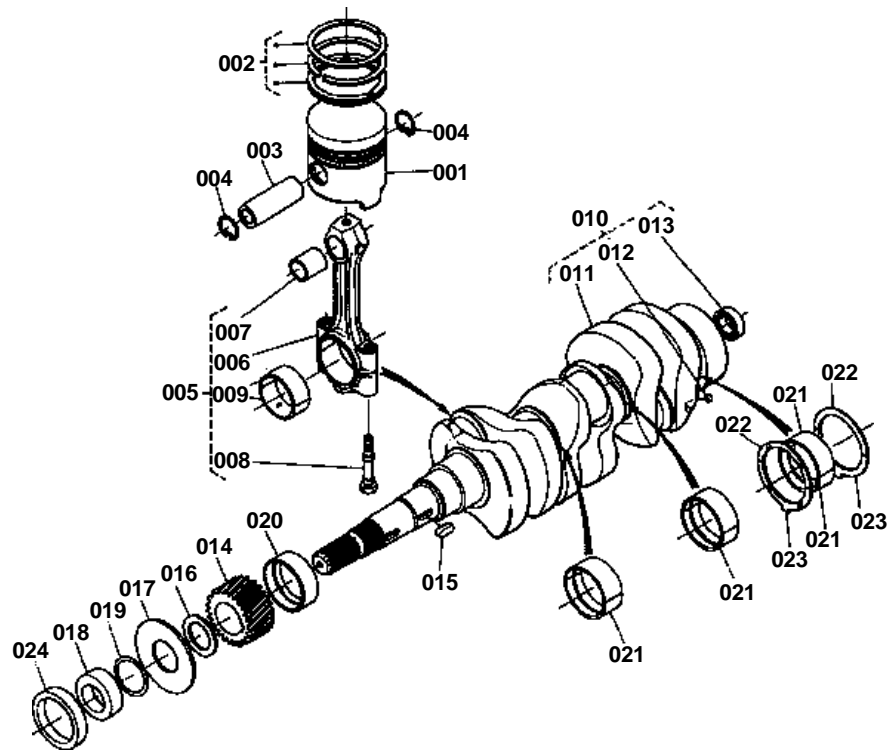



## PISTON CRANKSHAFT

↔ Interchangeable; ≠ not interchangeable; ← new for old; → old for new

REF.No	Part No.	Description	Q'ty	S.No.	I/C	REMARKS	Weight (kgf)	Weight (lb)
001	15201-21110	PISTON	3			STANDARD	0.54	1.188
001	15201-21910	PISTON	3			+0.5	0.545	1.199
002	15201-21050	ASSY PISTON RING	3			STANDARD	0	0
002	15201-21090	ASSY PISTON RING	3			+0.5	0	0
003	15521-21310	PISTON PIN	3				0.156	0.3432
004	15221-21330	CIR-CLIP PISTON PIN	6				0.002	0.0044
005	15521-22010	ASSY CONNECTING ROD	3				0	0
006	99999-99999	BLANK	0			ORDER BY REF.No.005	0	0
007	15221-21980	BUSH PISTON PIN	3				0	0
008	15521-22140	BOLT CONNECTING ROD	6				0	0
009	15221-22310	METAL CRANK PIN	6			STANDARD	0	0
009	15221-22970	METAL CRANK PIN	6			-0.2	0.04	0.088
009	15221-22980	METAL CRANK PIN	6			-0.4	0.04	0.088
010	15501-23010	ASSY CRANKSHAFT	1				13.42	29.524
011	99999-99999	BLANK	0			ORDER BY REF.No.010	0	0
012	15221-33630	PLUG PIN	3				0.001	0.0022
013	08121-06002	BEARING BALL	1				0.03	0.066
014	15521-24110	GEAR CRANKSHAFT	1				0.34	0.748
015	05712-00720	KEY FEATHER	1				0.008	0.0176
016	15221-24130	COLLAR CRANKGEAR	1				0.015	0.033
017	15221-23310	OIL SLINGER	1				0	0
018	15221-23250	COLLAR CRANKSHAFT	1				0	0
019	04811-10300	O RING	1				0.001	0.0022
020	15221-23470	METAL CRANKSHAFT 1	1			STANDARD	0	0
020	15221-23910	METAL CRANKSHAFT 1	1			-0.2	0	0
020	15221-23920	METAL CRANKSHAFT 1	1			-0.4	0	0
021	15221-23480	METAL CRANKSHAFT 2	6			STANDARD	0	0
021	15221-23930	METAL CRANKSHAFT 2	6			-0.2	0.055	0.121
021	15221-23940	METAL CRANKSHAFT 2	6			-0.4	0.056	0.1232
022	15521-23530	METAL SIDE 1	2			STANDARD	0.01	0.022
022	15221-23950	METAL SIDE 1	2			+0.2	0	0
022	15221-23960	METAL SIDE 1	2			+0.4	0	0
023	15521-23540	METAL SIDE 2	2			STANDARD	0	0
023	15221-23970	METAL SIDE 2	2			+0.2	0.009	0.0198
023	15221-23980	METAL SIDE 2	2			+0.4	0.009	0.0198
024	09550-00001	SEAL OIL	1				0.015	0.033

FLYWHEEL

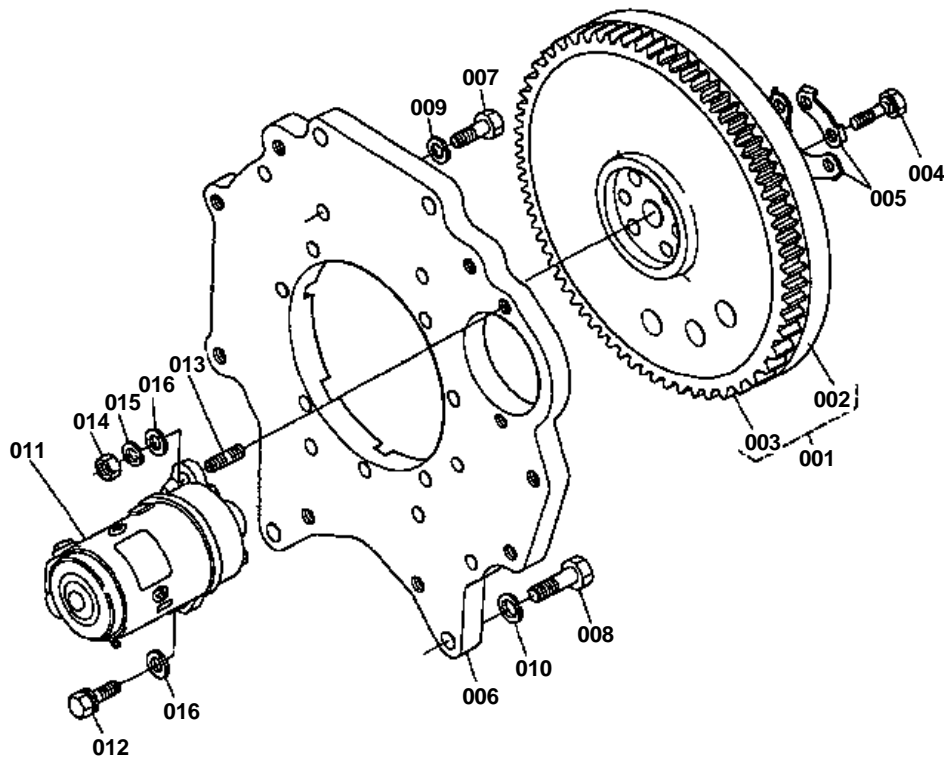

REF. № 04013-50100

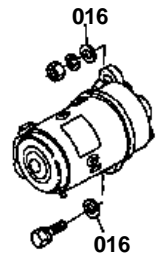

Discontinance.



FLYWHEEL

↔ Interchangeable; ≠ not interchangeable; ← new for old; → old for new

REF.No	Part No.	Description	Q'ty	S.No.	I/C	REMARKS	Weight (kgf)	Weight (lb)
001	15357-25010	ASSY FLYWHEEL	1				0	0
002	99999-99999	BLANK	0			ORDER BY REF.No.001	0	0
003	15606-63820	GEAR RING	1				1.44	3.168
004	15321-25160	BOLT FLYWHEEL	6				0.05	0.11
005	15321-25170	WASHER FLYWHEEL	3				0.01	0.022
006	15415-04620	PLATE REAR END	1				13	28.6
007	01073-51030	BOLT	11				0.028	0.0616
008	01073-51240	BOLT	2				0.049	0.1078
009	04512-50100	WASHER SPRING	11				0	0
010	04512-50120	WASHER SPRING	2				0	0
011	15601-63010	ASSY STARTER	1				0	0
012	01133-51030	BOLT	1				0.025	0.055
013	01517-51028	STUD	1				0.022	0.0484
014	02176-50100	NUT	1				0.005	0.011
015	04512-50100	WASHER SPRING	1				0	0
016	04013-50100	WASHER PLAIN	2			<=10101(F) <=10239(DT)	0	0





# NOZZLE HOLDER

↔ Interchangeable; ≠ not interchangeable; ← new for old; → old for new

REF.No	Part No.	Description	Q'ty	S.No.	I/C	REMARKS	Weight (kgf)	Weight (lb)
001	15221-42510	PIPE FUEL OVER FLOW	2				0.005	0.011
002	15221-51650	COVER INFECTION PUMP	1				0.05	0.11
003	15221-51660	GASKET PUMP COVER	1				0	0
004	01023-50612	BOLT	4				0.005	0.011
005	15271-53000	ASSY HOLDER NOZZLE	1				0.26	0.572
006	15271-53020	ASSY HOLDER NOZZLE	2				0.26	0.572
007	17011-53620	GASKET	3				0.003	0.0066
008	15221-53710	PIPE INJECTION	1				0	0
009	15221-53720	PIPE INJECTION	1				0	0
010	15321-53730	PIPE INJECTION	1				0	0
011	15121-53850	CLAMP PIPE	2				0	0
012	15121-53860	CLAMP PIPE	2				0	0
013	03024-50520	SCREW WITH WASHER	2				0.004	0.0088
014	15221-65510	GLOW PLUG	3				0.03	0.066
015	15401-65560	CORD GROW PLUG	2				0.005	0.011
016	14971-42750	CLIP PIPE	4				0.001	0.0022



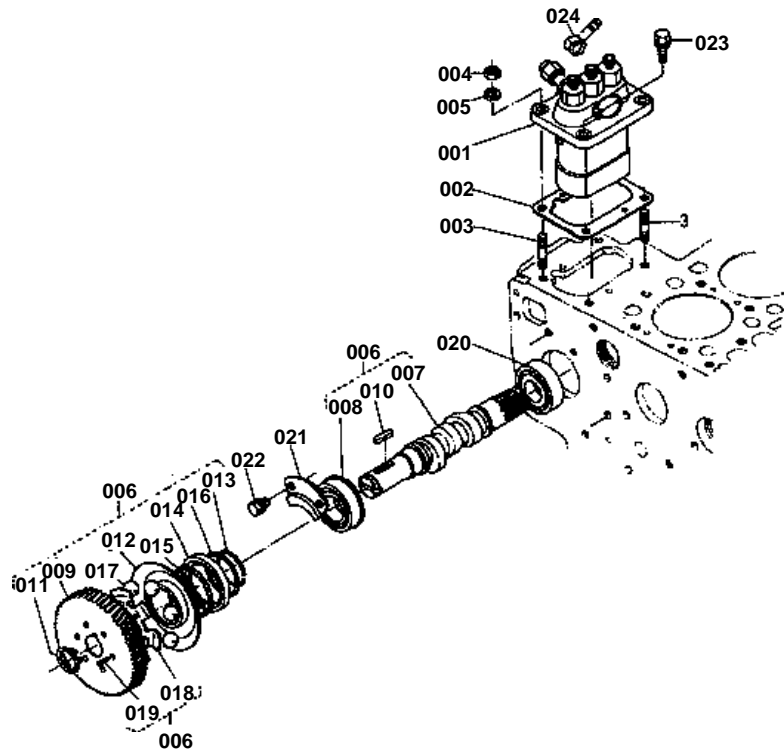

**FUEL CAMSHAFT**

↔ Interchangeable; ≠ not interchangeable; ← new for old; → old for new

REF.No	Part No.	Description	Q'ty	S.No.	I/C	REMARKS	Weight (kgf)	Weight (lb)
001	15321-51010	ASSY PUMP INJECTION	1				2	4.4
002	15321-52110	SHIM INJECTION PUMP	5				0	0
003	01513-50822	STUD	2				0.01	0.022
004	02156-50080	NUT	2				0.004	0.0088
005	04512-50080	WASHER SPRING	2				0	0
006	15321-16020	ASSY CAMSHAFT FUEL	1				2.4	5.28
007	15321-16173	CAMSHAFT FUEL	1				0	0
008	08153-06205	BEARING BALL	1				0.13	0.286
009	15221-51150	GEAR INJECTION PUMP	1				0.82	1.804
010	05712-00525	KEY FEATHER	1				0.005	0.011
011	04612-00240	CIR-CLIP EXTERNAL	1				0.002	0.0044
012	15221-55450	SLEEVE GOVERNOR	1				0.19	0.418
013	15221-55470	CIR-CLIP SLEEVE	1				0.003	0.0066
014	15221-55690	CASE GOVERNOR BALL	1				0	0
015	07715-03205	BALL	39				0.001	0.0022
016	15221-55740	CIR-CLIP BALL CASE	1				0.002	0.0044
017	07715-03219	BALL	6				0.014	0.0308
018	15221-55650	GUIDE GOVERNOR BALL	1				0.038	0.0836
019	05611-10310	RIVET	6				0.001	0.0022
020	08103-06205	BEARING BALL	1				0.12	0.264
021	15221-16320	STOPPER F-CAMSHAFT	1				0.02	0.044
022	01123-50814	BOLT	2				0	0
023	01123-50822	BOLT	2				0.012	0.0264
024	14111-42410	JOINT EYE	1				0.025	0.055

# SPEED CONTROL PLATE

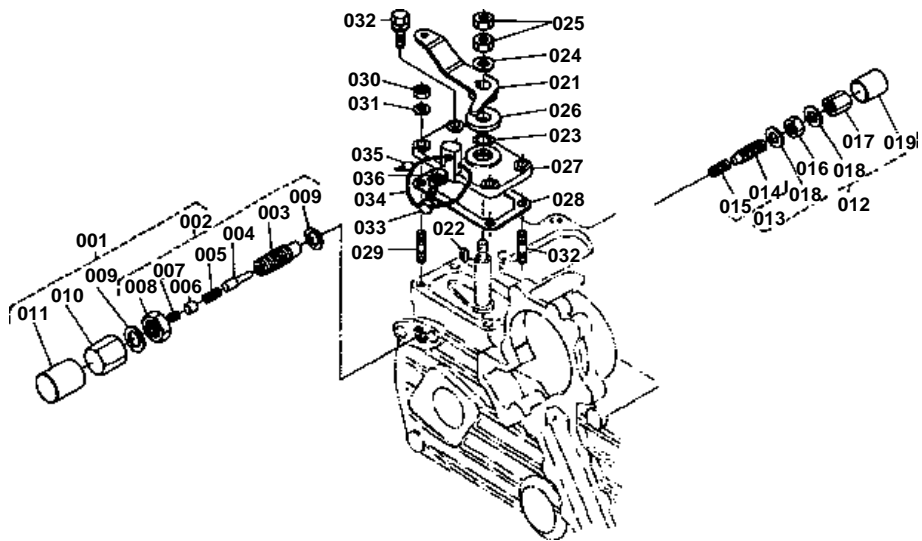



**SPEED CONTROL PLATE**

↔ Interchangeable; ≠ not interchangeable; ← new for old; → old for new

REF.No	Part No.	Description	Q'ty	S.No.	I/C	REMARKS	Weight (kgf)	Weight (lb)
001	15301-54020	ASSY APPARATUS FUEL	1				0	0
002	15301-54030	ASSY APPARATUS FUEL	1				0.037	0.0814
003	99999-99999	BLANK	0			ORDER BY REF.No.002	0	0
004	99999-99999	BLANK	0			ORDER BY REF.No.002	0	0
005	15261-54230	SPRING	1				0.001	0.0022
006	99999-99999	BLANK	0			ORDER BY REF.No.002	0	0
007	14301-54430	SCREW SET	1				0.001	0.0022
008	14301-54250	NUT LOCK	1				0.005	0.011
009	15221-54150	GASKET	2				0.001	0.0022
010	14301-54220	NUT CAP	1				0.015	0.033
011	14301-54420	CAP	1				0.005	0.011
012	15521-54090	ASSY APPARATUS IDLE	1				0.045	0.099
013	15521-54100	ASSY BOLT ADJUSTING	1				0.015	0.033
014	99999-99999	BLANK	0			ORDER BY REF.No.013	0	0
015	15521-54260	SPRING	1				0.001	0.0022
016	15401-92010	NUT	1				0.01	0.022
017	15521-92330	NUT CAP	1				0.02	0.044
018	15021-33660	GASKET	2				0.001	0.0022
019	15521-54270	CAP	1				0.003	0.0066
020	99999-99999	BLANK	0				0	0
021	15221-57150	LEVER SPEED CONTROL	1				0.07	0.154
022	05712-00408	KEY FEATHER	1				0.001	0.0022
023	04811-00120	O RING	1				0.001	0.0022
024	04013-50080	WASHER PLAIN	1				0	0
025	02112-50080	NUT	2				0.003	0.0066
026	17011-57380	PLATE FRICTION	1				0	0
027	15221-57110	PLATE SPEED CONTROL	1				0	0
028	15221-57210	GASKET CONT.PLATE	1				0	0
029	15221-88210	STUD	2				0.005	0.011
030	02056-50060	NUT	2				0.002	0.0044
031	04512-50060	WASHER SPRING	2				0	0
032	99999-99999	BLANK	0			NON SALE	0	0
033	99999-99999	BLANK	0			NON SALE	0	0
034	99999-99999	BLANK	0			NON SALE	0	0
035	99999-99999	BLANK	0			NON SALE	0	0
036	99999-99999	BLANK	0			NON SALE	0	0

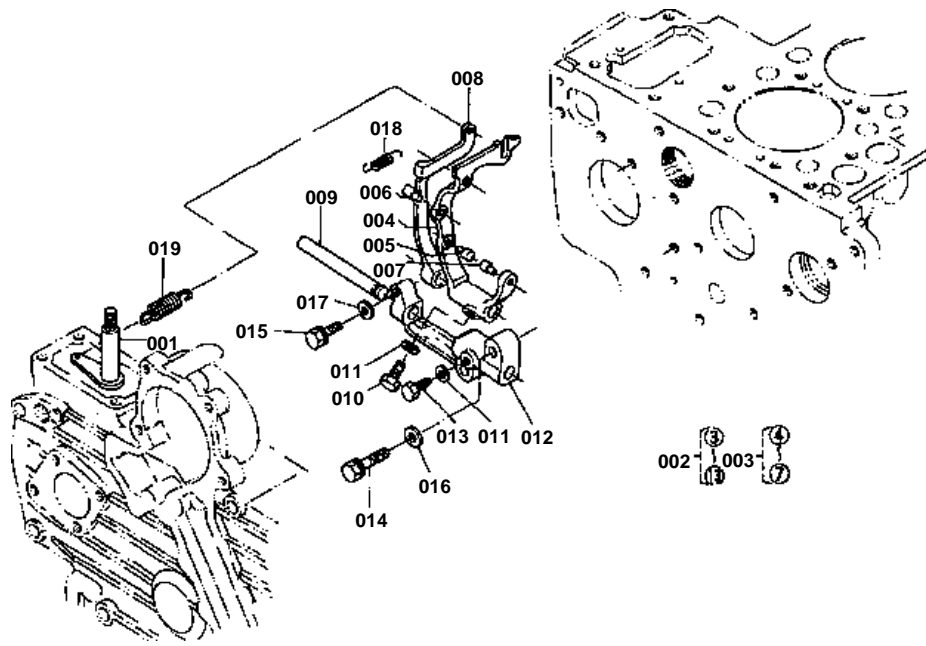

**GOVERNOR**

↔ Interchangeable; ≠ not interchangeable; ← new for old; → old for new

REF.No	Part No.	Description	Q'ty	S.No.	I/C	REMARKS	Weight (kgf)	Weight (lb)
001	15221-56020	ASSY LEVER GOVERNOR	1				0.06	0.132
002	15221-56050	ASSY LEVER FORK	1				0.385	0.847
003	15221-56040	ASSY LEVER FORK	1				0.144	0.3168
004	99999-99999	BLANK	0			ORDER BY REF.No.003	0	0
005	99999-99999	BLANK	0			ORDER BY REF.No.003	0	0
006	99999-99999	BLANK	0			ORDER BY REF.No.003	0	0
007	99999-99999	BLANK	0			ORDER BY REF.No.003	0	0
008	15221-56130	LEVER FORK	1				0.065	0.143
009	15221-56150	SHAFT FORK LEVER	1				0.1	0.22
010	15021-56240	BOLT LEVER SHAFT	1				0.005	0.011
011	04512-50060	WASHER SPRING	2				0	0
012	15221-56230	HOLDER FORK LEVER	1				0.1	0.22
013	15221-66410	BOLT	1				0.005	0.011
014	01123-50832	BOLT	2				0.016	0.0352
015	01023-50628	BOLT	1				0.015	0.033
016	04012-50080	WASHER PLAIN	2				0.001	0.0022
017	04012-50060	WASHER PLAIN	1				0.001	0.0022
018	15221-56480	SPRING START	1				0.008	0.0176
019	15321-56410	SPRING GOVERNOR	1				0.01	0.022

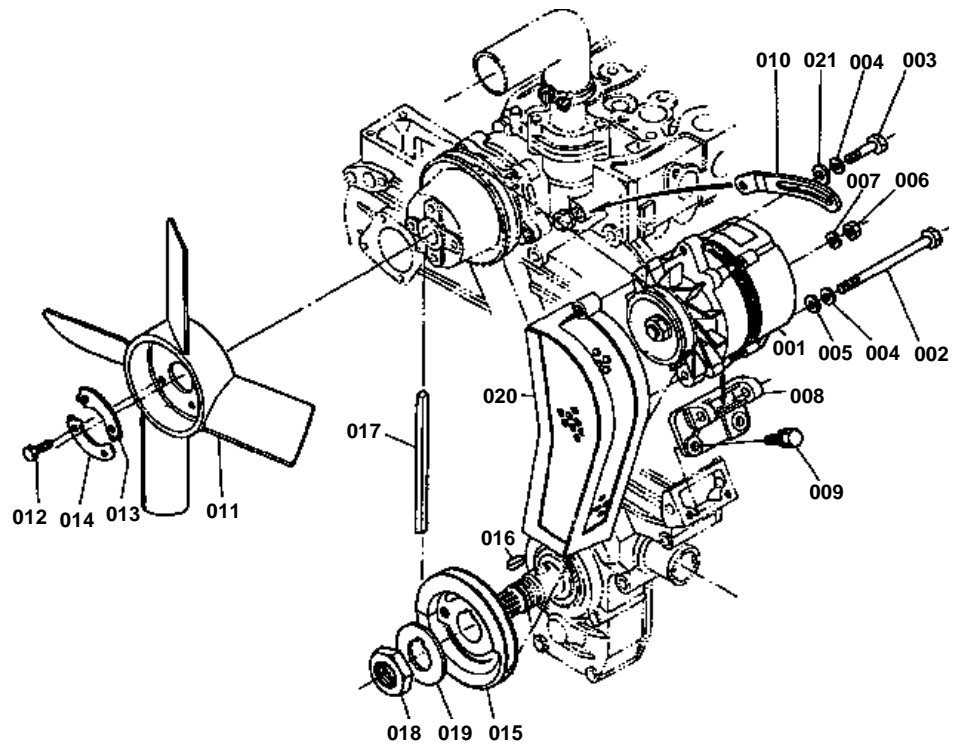

**DYNAMO**

↔ Interchangeable; ≠ not interchangeable; ← new for old; → old for new

REF.No	Part No.	Description	Q'ty	S.No.	I/C	REMARKS	Weight (kgf)	Weight (lb)
001	15411-64010	ASSY DYNAMO	1				3.25	7.15
002	15521-91030	BOLT	1				0	0
003	01153-50835	BOLT	1				0.016	0.0352
004	04512-50080	WASHER SPRING	2				0	0
005	04012-50080	WASHER PLAIN	1				0.001	0.0022
006	02056-50060	NUT	1				0.002	0.0044
007	04512-50060	WASHER SPRING	1				0	0
008	15321-64350	SUPPORT DYNAMO	1				0.29	0.638
009	01123-50825	BOLT	2				0.013	0.0286
010	15321-64420	STAY DYNAMO	1				0.1	0.22
011	15401-74110	FAN	1				0.34	0.748
012	01053-50610	BOLT	4				0.004	0.0088
013	15321-74230	WASHER FAN	1				0.005	0.011
014	15321-74240	WASHER FAN	1				0.004	0.0088
015	15321-74280	PULLEY FAN DRIVE	1				0	0
016	05712-00720	KEY FEATHER	1				0.008	0.0176
017	15401-97010	BELT FAN	1				0.08	0.176
018	15221-23360	NUT CRANKSHAFT	1				0.11	0.242
019	15221-23380	WASHER CRANKSHAFT	1				0.02	0.044
020	34260-13860	COVER BELT LH	1				0	0
021	04013-50080	WASHER PLAIN	1				0	0



# RADIATOR

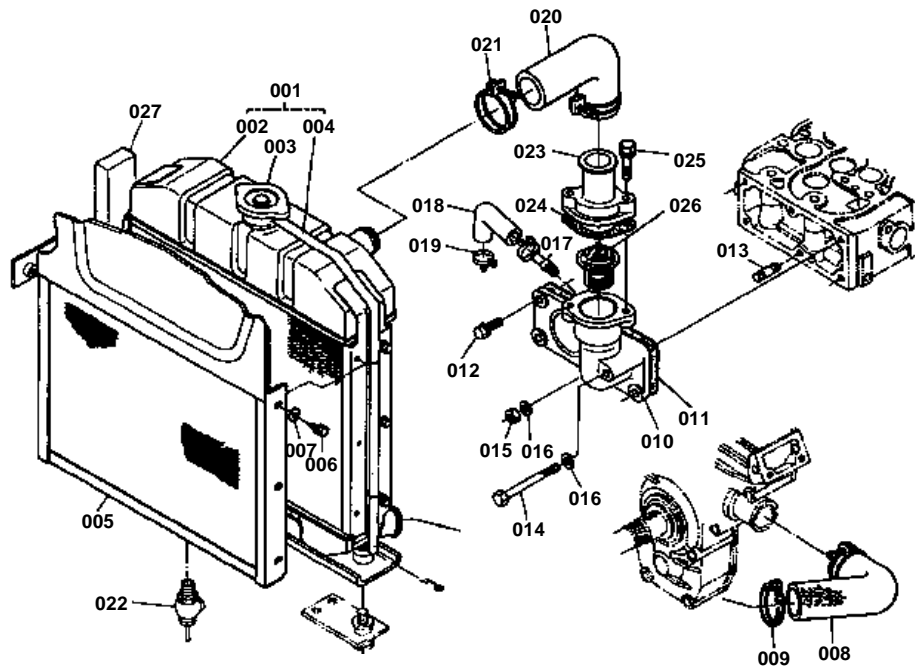

**RADIATOR**

↔ Interchangeable; ≠ not interchangeable; ← new for old; → old for new

REF.No	Part No.	Description	Q'ty	S.No.	I/C	REMARKS	Weight (kgf)	Weight (lb)
001	15411-72060	ASSY RADIATOR	1				0	0
002	99999-99999	BLANK	0			ORDER BY REF.No.001	0	0
003	15101-72030	CAP RADIATOR	1				0.075	0.165
004	15401-72710	PIPE WATER OVER FLOW	1				0.032	0.0704
005	15411-72250	NET RADIATOR	1				1.44	3.168
006	01023-50612	BOLT	6				0.005	0.011
007	04013-50060	WASHER PLAIN	6				0	0
008	15321-72850	PIPE WATER	1				0.181	0.3982
009	15108-72870	BAND	2				0.027	0.0594
010	15321-72910	FLANGE WATER	1				0	0
011	15221-72920	GASKET WATER FLANGE	1				0	0
012	01123-50822	BOLT	4				0.012	0.0264
013	01513-50822	STUD	1				0.01	0.022
014	01153-50870	BOLT	1				0.026	0.0572
015	02156-50080	NUT	1				0.004	0.0088
016	04512-50080	WASHER SPRING	2				0	0
017	15321-73340	PIPE WATER RETURN	1				0.016	0.0352
018	15321-73350	PIPE WATER RETURN	1				0.02	0.044
019	15109-73360	BAND PIPE	2				0.01	0.022
020	15401-72940	PIPE WATER	1				0.145	0.319
021	15108-72870	BAND	2				0.027	0.0594
022	14301-73110	COCK DRAIN	1				0.094	0.2068
023	15321-73260	COVER THERMOSTAT	1				0.107	0.2354
024	15321-73270	GASKET	1				0	0
025	01123-50835	BOLT	2				0.02	0.044
026	15321-73010	ASSY THERMOSTAT	1				0	0
027	37260-13730	CUSHION	2				0.02	0.044

# WATER PUMP

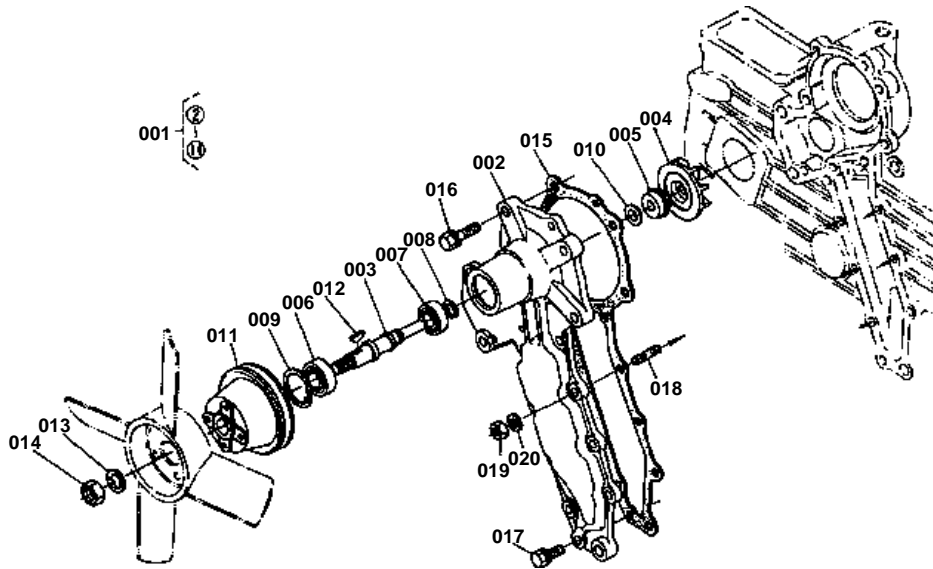



# WATER PUMP

↔ Interchangeable; ≠ not interchangeable; ← new for old; → old for new

REF.No	Part No.	Description	Q'ty	S.No.	I/C	REMARKS	Weight (kgf)	Weight (lb)
001	15301-73031	ASSY PUMP WATER	1				0	0
002	99999-99999	BLANK	0			ORDER BY REF.No.001	0	0
003	15321-73480	SHAFT WATER PUMP	1				0.19	0.418
004	15321-73510	IMPELLER WATER PUMP	1				0.22	0.484
005	15121-73050	SET SEAL	1				0	0
006	08143-06302	BEARING BALL	1				0.082	0.1804
007	08143-06202	BEARING BALL	1				0.043	0.0946
008	04612-00150	CIR-CLIP EXTERNAL	1				0.001	0.0022
009	04611-00420	CIR-CLIP INTERNAL	1				0.006	0.0132
010	15121-73620	SLINGER	1				0.002	0.0044
011	15401-74250	PULLEY FAN	1				0.73	1.606
012	05811-00416	KEY WOODRUFF	1				0.002	0.0044
013	04512-50140	WASHER SPRING	1				0	0
014	02076-50140	NUT	1				0.022	0.0484
015	15341-73430	GASKET WATER PUMP	1				0	0
016	01123-50828	BOLT	4				0.014	0.0308
017	01023-50618	BOLT	4				0.006	0.0132
018	15221-88210	STUD	5				0.005	0.011
019	02056-50060	NUT	5				0.002	0.0044
020	04512-50060	WASHER SPRING	5				0	0

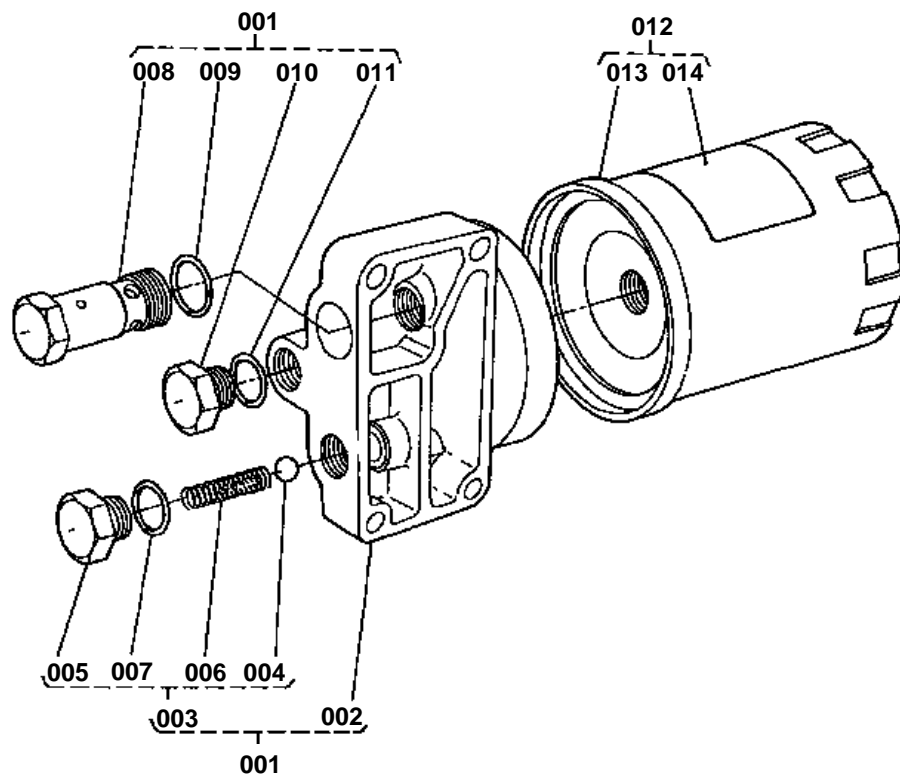



## OIL FILTER 2

↔ Interchangeable; ≠ not interchangeable; ← new for old; → old for new

REF.No	Part No.	Description	Q'ty	S.No.	I/C	REMARKS	Weight (kgf)	Weight (lb)
001	15213-32070	ASSY COVER FILTER	1				0.52	1.144
002	99999-99999	COVER	1			ORDER BY REF.No.001	0	0
003	15101-32700	ASSY VALVE SAFETY	1				0.036	0.0792
004	15101-36970	VALVE SAFETY	1				0.004	0.0088
005	15101-32940	PLUG	1				0.03	0.066
006	15101-36950	SPRING	1				0.002	0.0044
007	15101-36920	O RING	1				0.001	0.0022
008	15213-36070	ASSY VALVE RELIEF	1				0.13	0.286
009	04811-00080	O RING	1				0.001	0.0022
010	15213-32940	PLUG	1				0.017	0.0374
011	15213-36920	O RING	1				0.002	0.0044
012	15152-32090	ASSY CARTRIDGE	1				0.4	0.88
013	15213-32430	CARTRIDGE FILTER	1				0.355	0.781
014	15213-94400	LABEL OIL FILTER	1				0.001	0.0022

# STARTER

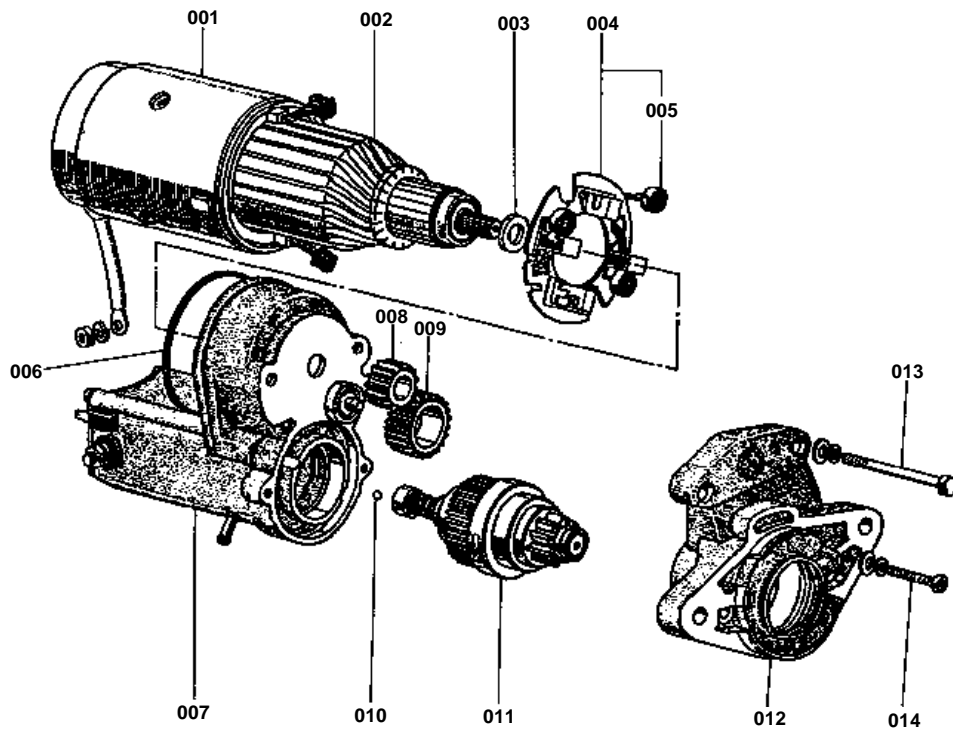

**STARTER**

↔ Interchangeable; ≠ not interchangeable; ← new for old; → old for new

REF.No	Part No.	Description	Q'ty	S.No.	I/C	REMARKS	Weight (kgf)	Weight (lb)
001	15401-63080	YOKE	1				1.2	2.64
002	15401-63070	ARMATURE	1				1.1	2.42
003	15401-96670	GASKET	1				0.001	0.0022
004	15401-63380	HOLDER BRUSH	1				0.1	0.22
005	15401-63390	SPRING BRUSH	4				0.003	0.0066
006	15401-96660	GASKET	1				0.002	0.0044
007	15521-63020	SWITCH MAGNET	1				1.29	2.838
008	15401-63260	GEAR 1	1				0.02	0.044
009	15401-63270	GEAR 2	1				0.043	0.0946
010	15451-97130	BALL	1				0	0
011	15601-63040	CLUTCH	1				0.75	1.65
012	15401-63030	FRAME DRIVE END	1				0.35	0.77
013	15401-63320	BOLT THROUGH	2				0.017	0.0374
014	15401-93310	SCREW	2				0.01	0.022



NOZZLE HOLDER 2

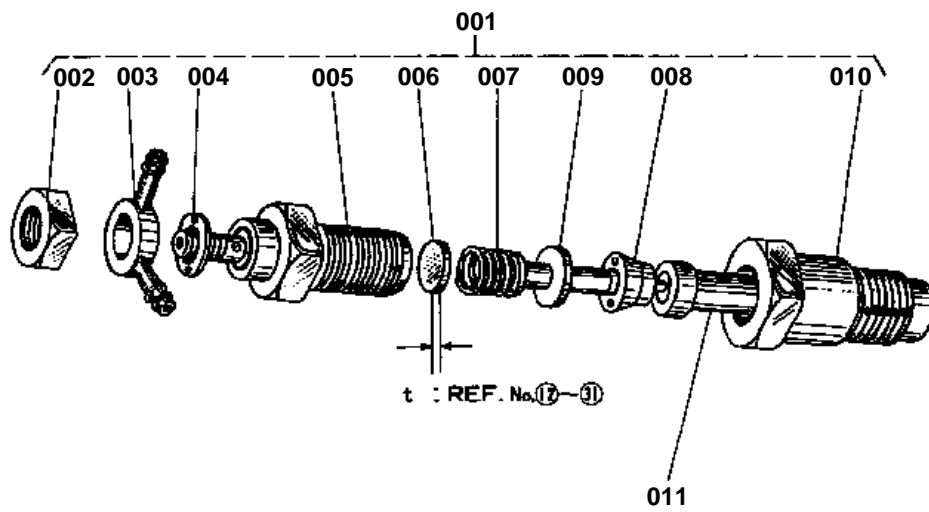

**NOZZLE HOLDER 2**

↔ Interchangeable; ≠ not interchangeable; ← new for old; → old for new

REF.No	Part No.	Description	Q'ty	S.No.	I/C	REMARKS	Weight (kgf)	Weight (lb)
001	15271-53020	ASSY HOLDER NOZZLE	4				0.26	0.572
002	15221-92020	NUT	4				0.011	0.0242
003	15221-95690	JOINT EYE	4				0.022	0.0484
004	15221-94020	WASHER PLAIN	4				0.002	0.0044
005	99999-99999	BLANK	0			ORDER BY REF.No.001	0	0
006	15221-53230	WASHER ADJUSTING	4				0.001	0.0022
007	15221-53170	SPRING NOZZLE	4				0.01	0.022
008	15221-53350	PIECE DISTANCE	4				0.016	0.0352
009	15221-53160	ROD PUSH	4				0.003	0.0066
010	15221-53280	NUT NOZZLE	4				0.068	0.1496
011	15021-53610	PIECE NOZZLE	4				0	0
012	15221-98110	WASHER ADJUSTING 100	1			1.00mm	0.001	0.0022
013	15221-98120	WASHER ADJUSTING 105	1			1.05mm	0.001	0.0022
014	15221-98130	WASHER ADJUSTING 110	1			1.10mm	0.001	0.0022
015	15221-98140	WASHER ADJUSTING 115	1			1.15mm	0.001	0.0022
016	15221-98150	WASHER ADJUSTING 120	1			1.20mm	0.001	0.0022
017	15221-98160	WASHER ADJUSTING 125	1			1.25mm	0.001	0.0022
018	15221-98170	WASHER ADJUSTING 130	1			1.30mm	0.001	0.0022
019	15221-98180	WASHER ADJUSTING 135	1			1.35mm	0.001	0.0022
020	15221-98190	WASHER ADJUSTING 140	1			1.40mm	0.002	0.0044
021	15221-98200	WASHER ADJUSTING 145	1			1.45mm	0.001	0.0022
022	15221-98210	WASHER ADJUSTING 150	1			1.50mm	0.001	0.0022
023	15221-98220	WASHER ADJUSTING 155	1			1.55mm	0.003	0.0066
024	15221-98230	WASHER ADJUSTING 160	1			1.60mm	0.003	0.0066
025	15221-98240	WASHER ADJUSTING 165	1			1.65mm	0.002	0.0044
026	15221-98250	WASHER ADJUSTING 170	1			1.70mm	0.002	0.0044
027	15221-98260	WASHER ADJUSTING 175	1			1.75mm	0.002	0.0044
028	15221-98270	WASHER ADJUSTING 180	1			1.80mm	0.002	0.0044
029	15221-98280	WASHER ADJUSTING 185	1			1.85mm	0.002	0.0044
030	15221-98290	WASHER ADJUSTING 190	1			1.90mm	0.002	0.0044
031	15221-98300	WASHER ADJUSTING 195	1			1.95mm	0.003	0.0066

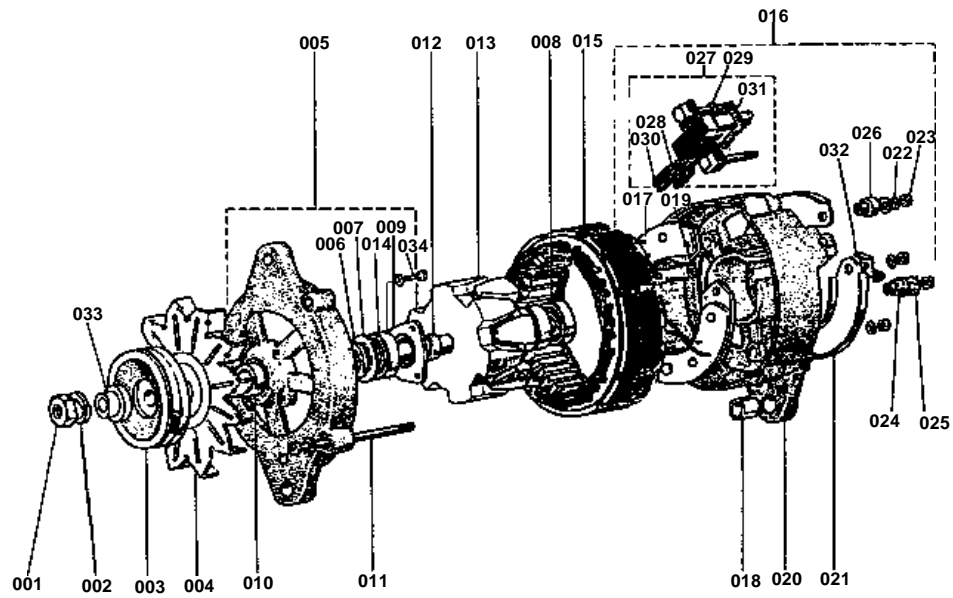

**DYNAMO**

↔ Interchangeable; ≠ not interchangeable; ← new for old; → old for new

REF.No	Part No.	Description	Q'ty	S.No.	I/C	REMARKS	Weight (kgf)	Weight (lb)
001	15221-92010	NUT	1				0.012	0.0264
002	15221-94070	WASHER SPRING	1				0.008	0.0176
003	15221-64110	PULLEY DYNAMO	1				0.198	0.4356
004	15221-64130	FAN DYNAMO	1				0	0
005	15321-64020	FRAME DRIVE END	1				0	0
006	15221-64790	FELT OIL	1				0.001	0.0022
007	15221-64830	COVER FELT	1				0.003	0.0066
008	08121-06201	BEARING BALL	1				0.036	0.0792
009	15221-64710	PLATE RETAINER	1				0.018	0.0396
010	15221-64150	COLLAR	1				0.008	0.0176
011	15321-64260	BOLT THROUGH	2				0.008	0.0176
012	15321-64170	SPACER	1				0.007	0.0154
013	15321-64030	ARMATURE	1				1.29	2.838
014	08141-06202	BEARING BALL	1				0.043	0.0946
015	15321-64050	YOKE	1				0.75	1.65
016	15321-64070	ASSY FRAME END	1				0.52	1.144
017	15321-64850	ASSY RELTIFIER	1				0.134	0.2948
018	15221-64210	BUSH	1				0.007	0.0154
019	15321-64880	WASHER INSULATION	1				0.001	0.0022
020	15321-64060	FRAME END	1				0.298	0.6556
021	15321-64230	COVER END	1				0.029	0.0638
022	04512-50050	WASHER SPRING	5				0	0
023	15221-92030	NUT	5				0.001	0.0022
024	15321-64920	BUSH INSULATION	1				0.001	0.0022
025	14611-51400	WASHER	1				0	0
026	15221-64910	BUSH INSULATION	1				0.001	0.0022
027	15321-64310	ASSY HOLDER BRUSH	1				0.039	0.0858
028	15221-64330	SPRING BRUSH	2				0.001	0.0022
029	15321-64920	WASHER INSULATION	2				0.001	0.0022
030	15221-64090	BRUSH	2				0.002	0.0044
031	15321-64940	INSULATER TERMINAL	1				0.001	0.0022
032	15321-67570	CLAMP CORD	1				0.04	0.088
033	15321-64170	SPACER	1				0.007	0.0154

# INJECTION PUMP

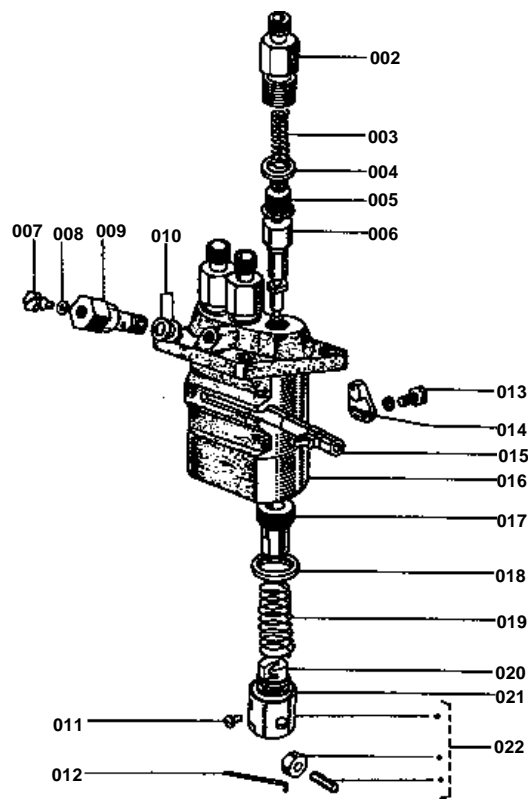



# INJECTION PUMP

↔ Interchangeable; ≠ not interchangeable; ← new for old; → old for new

REF.No	Part No.	Description	Q'ty	S.No.	I/C	REMARKS	Weight (kgf)	Weight (lb)
001	15321-51010	ASSY PUMP FUEL INJEC	1				2	4.4
002	15601-51220	HOLDER DELIVERY VALV	3				0.055	0.121
003	15221-51230	SPRING DELIVERY VALV	3				0.002	0.0044
004	15221-51240	GASKET DELIVERY VALV	3				0.001	0.0022
005	15221-51030	VALVE DELIVERY	3				0.012	0.0264
006	15221-51050	ELEMENT PUMP	3				0.053	0.1166
007	15221-51350	SCREW	1				0.008	0.0176
008	15221-96660	GASKET	1				0.002	0.0044
009	15221-51320	SCREW	1				0.032	0.0704
010	15221-96650	GASKET	2				0.001	0.0022
011	15221-51250	PIN TAPPET GUIDE	3				0.001	0.0022
012	15321-51430	PIN CRANK	1				0.001	0.0022
013	15221-91030	BOLT	2				0	0
014	15221-51390	PLATE ADJUSTING	2				0	0
015	15321-51060	RACK CONTROL	1				0.038	0.0836
016	99999-99999	BLANK	0			ORDER BY REF.No.001	0	0
017	15221-51380	SLEEVE CONTROL	3				0	0
018	15221-51270	SEAT SPRING UPPER	2				0.004	0.0088
019	15221-51280	SPRING PLUNGER	3				0.015	0.033
020	15221-51290	SEAT SPRING LOWER	3				0.01	0.022
021	15221-51490	SHIM	3				0.002	0.0044
022	15221-51070	ASSY TAPPET	3				0.039	0.0858

# FRONT WHEEL

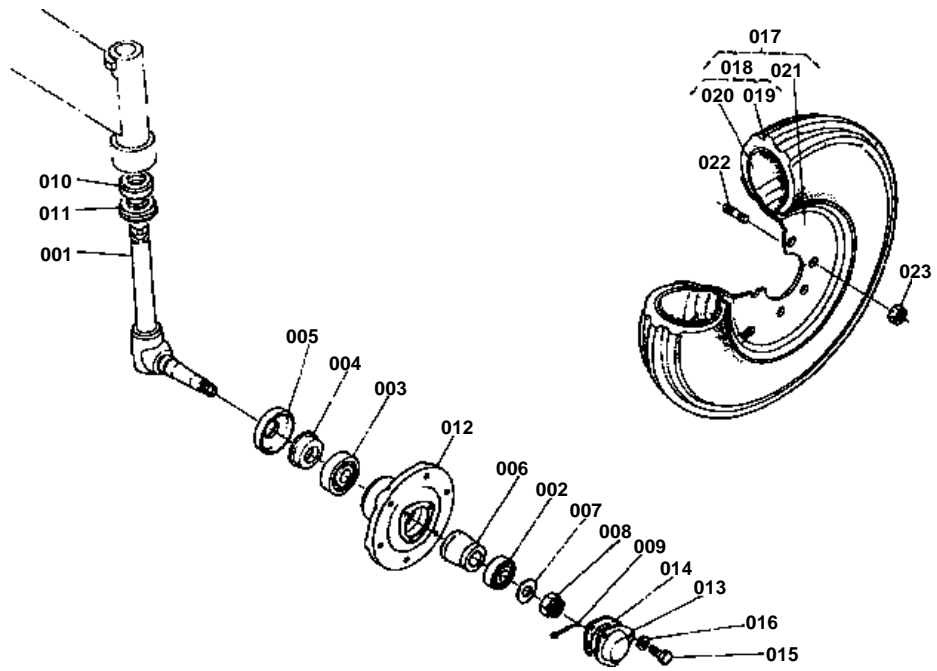

**FRONT WHEEL**

↔ Interchangeable; ≠ not interchangeable; ← new for old; → old for new

REF.No	Part No.	Description	Q'ty	S.No.	I/C	REMARKS	Weight (kgf)	Weight (lb)
001	35300-11110	ASSY SHAFT KNUCKLE	2				2.7	5.94
002	08101-06205	BEARING BALL	2				0.14	0.308
003	08101-06206	BEARING BALL	2				0.196	0.4312
004	37300-11160	SEAL OIL	2				0.08	0.176
005	32240-11480	COVER DUST	2				0.08	0.176
006	38240-11420	SPACER	2				0.205	0.451
007	04011-50200	WASHER PLAIN	2				0.015	0.033
008	02372-50200	NUT SLOTTED	2				0.024	0.0528
009	05511-50435	PIN SPLIT	2				0.004	0.0088
010	32150-11510	BEARING THRUST BALL	2				0.14	0.308
011	37300-11430	SEAL OIL	2				0.05	0.11
012	35340-11310	HUB FRONT WHEEL	2				3.74	8.228
013	32240-11350	CAP FRONT WHEEL	2				0.065	0.143
014	32150-11360	GASKET	2				0	0
015	01150-50814	BOLT	6				0.01	0.022
016	04512-50080	WASHER SPRING	6				0	0
017	70000-00160	ASSY FRONT WHEEL	2				0	0
017	35340-11600	ASSY FRONT WHEEL (5.	2				18.7	41.14
018	31820-11610	ASSY TIRE (5.50-16)	2				1.1	2.42
019	70000-00161	TIRE	2				0	0
019	31820-11620	TIRE	2				6.5	14.3
020	70000-00162	TUBE	2				0	0
020	32270-11630	TUBE	2				0.95	2.09
021	70000-00088	DISK FRONT WHEEL RIM	2				0	0
021	35340-11640	DISK FRONT WHEEL RIM	2				0	0
022	01517-51425	STUD	12				0.047	0.1034
023	35340-11390	NUT	12				0.03	0.066



# STEERING LINKAGE

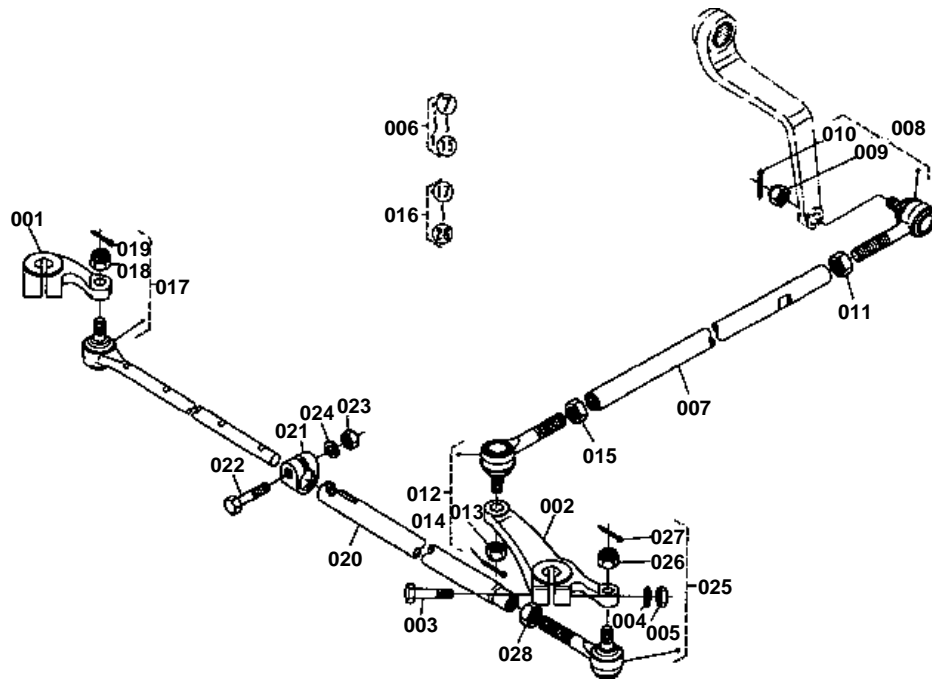



## STEERING LINKAGE

↔ Interchangeable; ≠ not interchangeable; ← new for old; → old for new

REF.No	Part No.	Description	Q'ty	S.No.	I/C	REMARKS	Weight (kgf)	Weight (lb)
001	35340-11210	ARM KNUCKLE RH	1				0	0
002	35340-11220	ARM KNUCKLE LH	1				0	0
003	35340-11270	BOLT	2				0.07	0.154
004	04512-50120	WASHER SPRING	2				0	0
005	02176-50120	NUT	2				0.01	0.022
006	35320-12200	ASSY LINK DRAG	1				2.9	6.38
007	35320-12210	LINK DRAG	1				1.65	3.63
008	35270-12600	ASSY END TIE ROD RH	1				0.5	1.1
009	35270-12670	NUT SLOTTED	1				0.014	0.0308
010	05511-50328	PIN SPLIT	1				0.002	0.0044
011	02172-50200	NUT	1				0.03	0.066
012	35320-12700	ASSY END TIE ROD LH	1				0.51	1.122
013	35270-12670	NUT SLOTTED	1				0.014	0.0308
014	05511-50328	PIN SPLIT	1				0.002	0.0044
015	38630-44980	NUT	1				0.01	0.022
016	35340-12400	ASSY ROD TIE	1				3.5	7.7
017	35340-12410	ASSY TIE ROD MIDDLE	1				1.385	3.047
018	35270-12670	NUT SLOTTED	1				0.014	0.0308
019	05511-50325	PIN SPLIT	1				0.002	0.0044
020	35340-12450	TIE ROD OUTER	1				1.28	2.816
021	33251-62860	CLMP TIE ROD	1				0.078	0.1716
022	38430-12560	BOLT	1				0.35	0.77
023	02176-50100	NUT	1				0.005	0.011
024	04512-50100	WASHER SPRING	1				0	0
025	36200-62930	ASSY END TIE ROD	1				0	0
026	35270-12670	NUT SLOTTED	1				0.014	0.0308
027	05511-50325	PIN SPLIT	1				0.002	0.0044
028	33251-62920	NUT	1				0.022	0.0484

# FRONT AXLE BRACKET

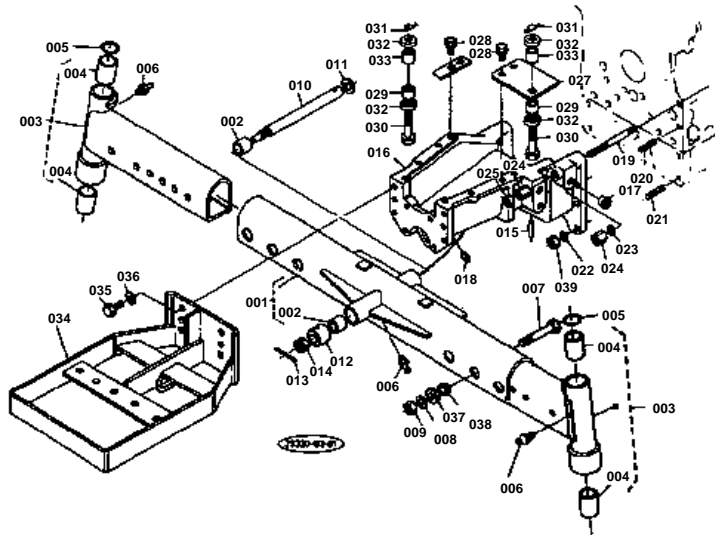

REF. No. 37300-1375-0

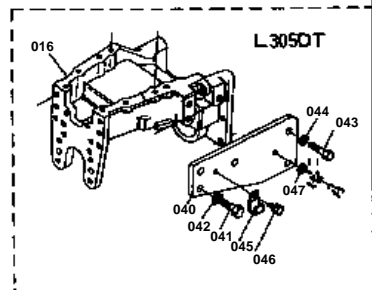



# FRONT AXLE BRACKET

↔ Interchangeable; ≠ not interchangeable; ← new for old; → old for new

REF.No	Part No.	Description	Q'ty	S.No.	I/C	REMARKS	Weight (kgf)	Weight (lb)
001	35340-13110	AXLE FRONT MIDDLE	1				18.5	40.7
002	32150-11530	BUSH	2				0.063	0.1386
003	35340-13120	AXLE FRONT OUTER	2				5.05	11.11
004	32150-11530	BUSH	4				0.063	0.1386
005	04811-00280	O RING	2				0.002	0.0044
006	06613-10010	NIPPLE GREASE	3				0.006	0.0132
007	35340-13140	BOLT	4				0.145	0.319
008	04512-50140	WASHER SPRING	4				0	0
009	02176-50140	NUT	4				0.014	0.0308
010	37300-13410	PIN CENTER	1				1.26	2.772
011	34220-13450	COLLAR	1				0.021	0.0462
012	37300-13460	COLLAR ADJUSTING	1				0.23	0.506
013	32210-13480	NUT ADJUSTING	1				0.112	0.2464
014	05511-50440	PIN SPLIT	1				0.004	0.0088
015	05411-01050	PIN SPRING	1				0.019	0.0418
016	37300-13610	BRACKET FRONT AXLE	1				15.1	33.22
017	31220-14290	PLUG	3				0.002	0.0044
018	06613-10010	NIPPLE GREASE	1				0.006	0.0132
019	35340-13640	STUD	2				0.076	0.1672
020	01519-51030	STUD	1				0.025	0.055
021	01574-51232	STUD	4				0.039	0.0858
022	04512-50120	WASHER SPRING	4				0	0
023	04512-50100	WASHER SPRING	2				0	0
024	37300-14190	NUT	3				0.009	0.0198
025	02116-50100	NUT	1				0.004	0.0088
026	37300-13750	SUPPORT RADIATOR RH	1				0.38	0.836
026	35340-13750	SUPPORT RADIATOR RH	1	>=10001			0.33	0.726
027	37300-13760	SUPPORT RADIATOR LH	1				0.36	0.792
028	01130-51020	BOLT	4				0	0
029	15111-72180	CUSHION	2				0.015	0.033
030	15108-72380	BOLT	2				0.04	0.088
031	05515-51000	PIN SNAP	2				0	0
032	15111-72200	WASHER	4				0.013	0.0286
033	15111-72190	CUSHION	2				0.016	0.0352
034	35300-13810	BUMPER	1				12.5	27.5
035	01173-51225	BOLT	6				0.033	0.0726
036	04512-50120	WASHER SPRING	8				0	0
037	35110-71830	COLLAR	4				0.078	0.1716
037	35114-71830	COLLAR	4	>=10001			0.065	0.143
038	37310-13180	SPACER	4				0.035	0.077
039	02176-50120	NUT	4				0.01	0.022

# BATTERY

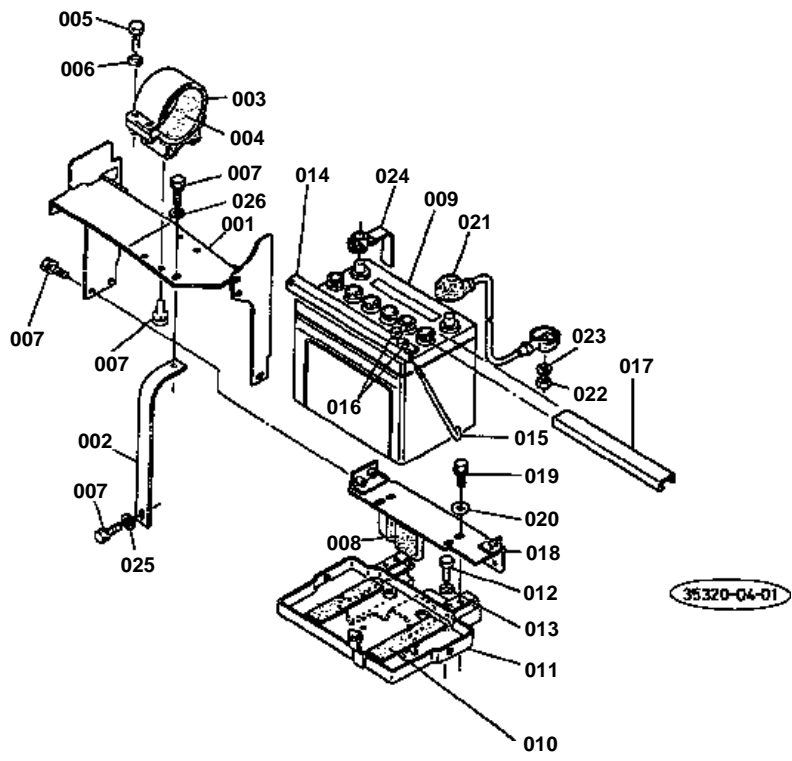

**BATTERY**

↔ Interchangeable; ≠ not interchangeable; ← new for old; → old for new

REF.No	Part No.	Description	Q'ty	S.No.	I/C	REMARKS	Weight (kgf)	Weight (lb)
001	35300-13910	SUPPORT AIR CLEANER	1				4.4	9.68
002	35300-13920	STAY A/C SUPPORT	1				0.235	0.517
003	34260-13960	BAND AIR CLEANER	1				0.675	1.485
004	34260-13970	CUSHION BAND	1				0.065	0.143
005	01150-50838	BOLT	2				0.017	0.0374
006	04512-50080	WASHER SPRING	2				0	0
007	01120-50820	BOLT	7				0	0
008	37260-18050	CUSHION	1				0.01	0.022
009	32360-33200	BATTERY	1				18	39.6
010	32350-33230	CUSHION	2				0.03	0.066
011	35300-33210	SUPPORT BATTERY	1				6.7	14.74
012	01170-51020	BOLT	4				0	0
013	04512-50100	WASHER SPRING	4				0	0
014	32350-33270	RETAINER BATTERY	1				0.35	0.77
015	34260-33290	BOLT	2				0.08	0.176
016	02112-50080	NUT	4				0.003	0.0066
017	34260-33390	COVER BATTERY	1				0.053	0.1166
018	35300-13710	PLATE BAFFLE	1				1.55	3.41
019	01123-50818	BOLT	2				0.012	0.0264
020	04015-50080	WASHER PLAIN	2				0	0
021	34260-33330	CORD BATTERY	1				0.25	0.55
022	02114-50080	NUT	1				0.005	0.011
023	04512-50080	WASHER SPRING	1				0	0
024	34200-33380	CORD EATH	1				0.19	0.418
025	04012-50080	WASHER PLAIN	2				0.001	0.0022

# FLYWHEEL HOUSING

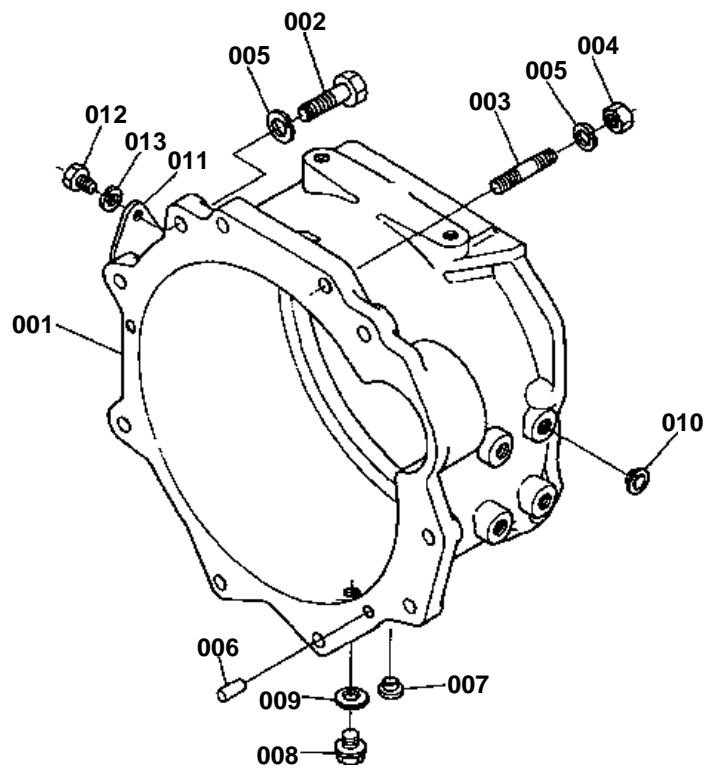



# FLYWHEEL HOUSING

↔ Interchangeable; ≠ not interchangeable; ← new for old; → old for new

REF.No	Part No.	Description	Q'ty	S.No.	I/C	REMARKS	Weight (kgf)	Weight (lb)
001	35340-14100	HOUSING FLYWHEEL	1				20.1	44.22
002	01173-51242	BOLT	8				0.047	0.1034
003	01574-51260	STUD	2				0	0
004	02174-50120	NUT	2				0.01	0.022
005	04512-50120	WASHER SPRING	10				0	0
006	05012-01020	PIN STRAIGHT	2				0.02	0.044
007	32210-27580	PLUG	2				0.001	0.0022
008	06311-25010	PLUG	1				0.014	0.0308
009	04717-01000	WASHER SEAL	1				0.001	0.0022
010	31220-14290	PLUG	8				0.002	0.0044
011	31220-14170	COVER	1				0.014	0.0308
012	01053-50812	BOLT	1				0.009	0.0198
013	04512-50080	WASHER SPRING	1				0	0



# CLUTCH HOUSING

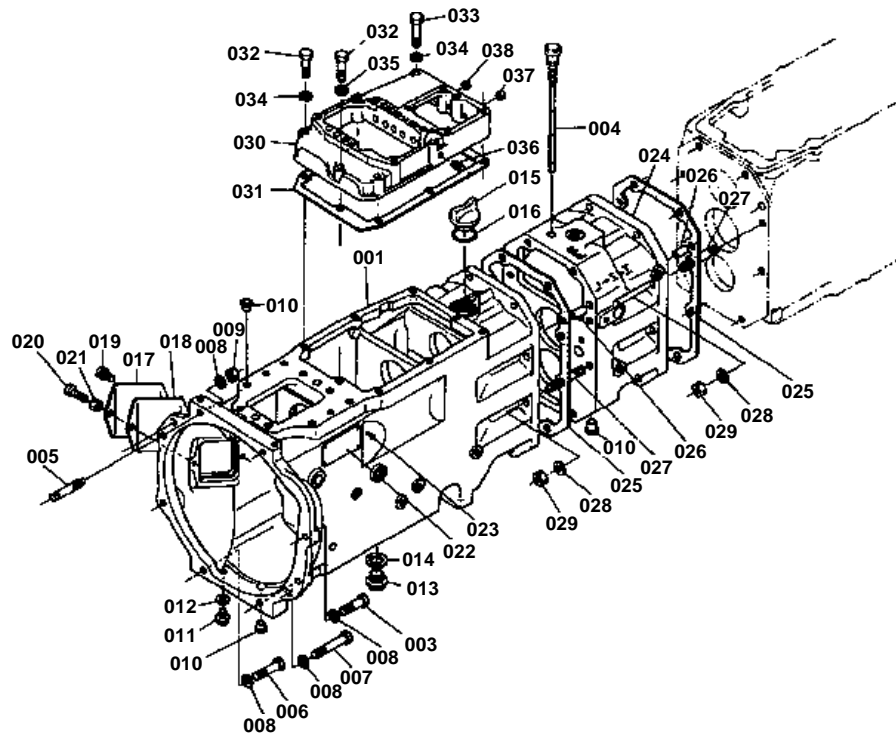

**CLUTCH HOUSING**

↔ Interchangeable; ≠ not interchangeable; ← new for old; → old for new

REF.No	Part No.	Description	Q'ty	S.No.	I/C	REMARKS	Weight (kgf)	Weight (lb)
001	35340-14110	HOUSING CLUCTH	1				49	107.8
002	99999-99999	BLANK	0				0	0
003	01173-51040	BOLT	4				0.028	0.0616
004	35340-14190	GAUGE OIL	1				0.02	0.044
005	37300-14130	STUD	2				0.345	0.759
006	01173-51050	BOLT	1				0.035	0.077
007	01173-51070	BOLT	1				0.044	0.0968
008	04512-50100	WASHER SPRING	8				0	0
009	37300-14190	NUT	2				0.009	0.0198
010	32210-27580	PLUG	10				0.001	0.0022
011	06311-55010	PLUG	2				0.015	0.033
012	04717-01000	WASHER SEAL	2				0.001	0.0022
013	34150-14260	PLUG DRAIN	1				0	0
014	04717-02150	WASHER SEAL	1				0.004	0.0088
015	38430-21410	PLUG	1				0.045	0.099
016	04811-50300	O RING	1				0.001	0.0022
017	34150-14160	COVER HOUSING	1				0.15	0.33
018	34150-14170	GASKET HOUSING	1				0.03	0.066
019	01120-50816	BOLT	1				0	0
020	01150-50825	BOLT	1				0	0
021	02114-50080	NUT	1				0.005	0.011
022	35320-19830	LABEL	1				0.01	0.022
023	34152-57920	RIVET	4				0.001	0.0022
024	35340-14150	CASE MID	1				14.9	32.78
025	35340-14140	GASKET	2				0.01	0.022
026	05012-01018	PIN STRAIGHT	4				0.012	0.0264
027	35340-14180	STUD	16				0	0
028	04512-50120	WASHER SPRING	16				0	0
029	35340-27360	NUT	16				0.015	0.033
030	37150-21210	COVER SPEED CHANGE	1				1.14	2.508
031	34650-59140	GASKET	1				0	0
032	01153-50840	BOLT	3				0.018	0.0396
033	01153-50850	BOLT	3				0.02	0.044
034	04512-50080	WASHER SPRING	5				0	0
035	04717-00800	WASHER SEAL	1				0.001	0.0022
036	34150-23960	PLUG	2				0	0
037	34150-21250	PLUG	5				0.002	0.0044
038	34269-21250	PLUG 12	1				0	0

# CLUTCH

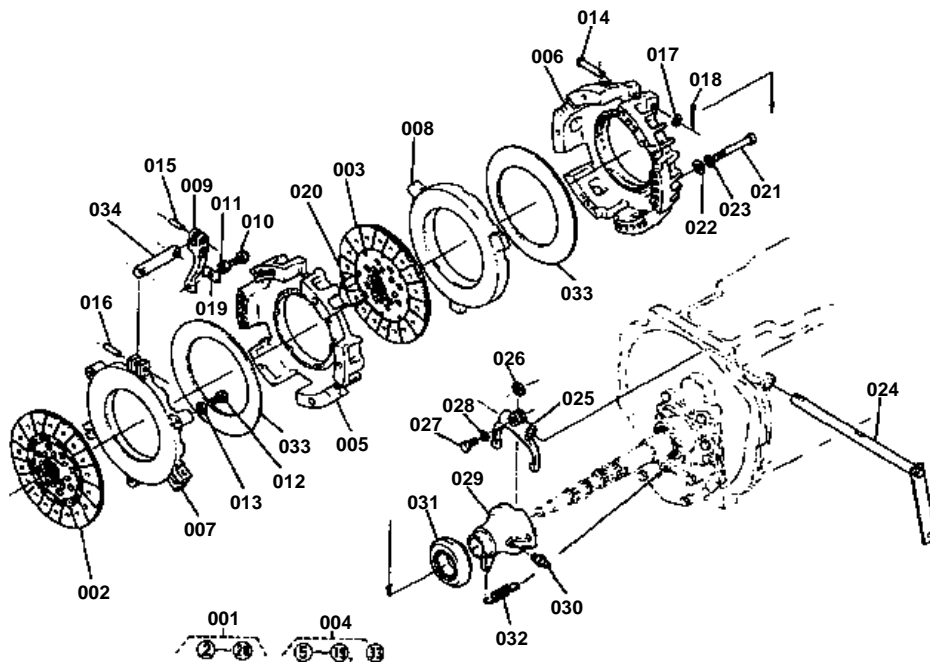

**CLUTCH**

↔ Interchangeable; ≠ not interchangeable; ← new for old; → old for new

REF.No	Part No.	Description	Q'ty	S.No.	I/C	REMARKS	Weight (kgf)	Weight (lb)
001	35340-14200	ASSY CLUTCH DUAL	1				0	0
002	34370-14300	ASSY DISK CLUTCH 1	1				0	0
003	35340-14400	ASSY DISK CLUTCH 2	1				0	0
004	35340-14500	ASSY PLATE PRESSURE	1				20	44
005	35340-14410	COVER CLUTCH 1	1				5.8	12.76
006	34370-14420	COVER CLUTCH 2	1				5.6	12.32
007	35340-14430	PLATE PRESSURE 1	1				3.1	6.82
008	35340-14440	PLATE PRESSURE 2	1				1.08	2.376
009	99999-99999	BLANK	0			ORDER BY REF.No.035	0	0
010	99999-99999	BLANK	0			ORDER BY REF.No.036 OR 038	0	0
011	99999-99999	BLANK	0			ORDER BY REF.No.036 OR 038	0	0
012	35340-14580	BOLT	3				0.009	0.0198
013	02176-50100	NUT	3				0.005	0.011
014	34370-14560	PIN JOINT	3				0.028	0.0616
015	34370-14570	PIN STRAIGHT	3				0.016	0.0352
016	34370-14580	PIN STRAIGHT	3				0.014	0.0308
017	04012-50080	WASHER PLAIN	3				0.001	0.0022
018	05511-51215	PIN SPLIT	3				0.001	0.0022
019	99999-99999	BLANK	0			ORDER BY REF.No.036 OR 038	0	0
020	34370-14590	KNOCK PIPE	2				0.01	0.022
021	01153-50880	BOLT	6				0.03	0.066
022	04013-50080	WASHER PLAIN	6				0	0
023	04512-50080	WASHER SPRING	6				0	0
024	37220-14712	LEVER CLUTCH	1				0.475	1.045
025	35340-14720	FORK CLUTCH RELEASE	1				0.37	0.814
026	31150-14780	KEY FORK	1				0.003	0.0066
027	01153-50828	BOLT	1				0.014	0.0308
028	04512-50080	WASHER SPRING	1				0	0
029	35340-14810	HUB CLUTCH RELEASE	1				1.08	2.376
030	06613-10675	NIPPLE GREASE	1				0.003	0.0066
031	34370-14820	BEARING RELEASE	1				0.46	1.012
032	32150-14840	SPRING RELEASE HUB	1				0.005	0.011
033	35340-14520	SPRING DIAPHRAGM	2				0.435	0.957
034	35340-14530	SUB ASSY RELEASE ROD	3				0.1	0.22
035	35340-99360	MANUAL	1			NOT SHOWN IN FIG.	0	0
036	35340-99350	KIT LEVER RELEASE	1			SET	0.58	1.276
037	35340-99380	MANUAL	1			NOT SHOWN IN FIG.	0	0
038	35340-99370	KIT BOLT NUT	1			SET	0.075	0.165

# CLUTCH PEDAL

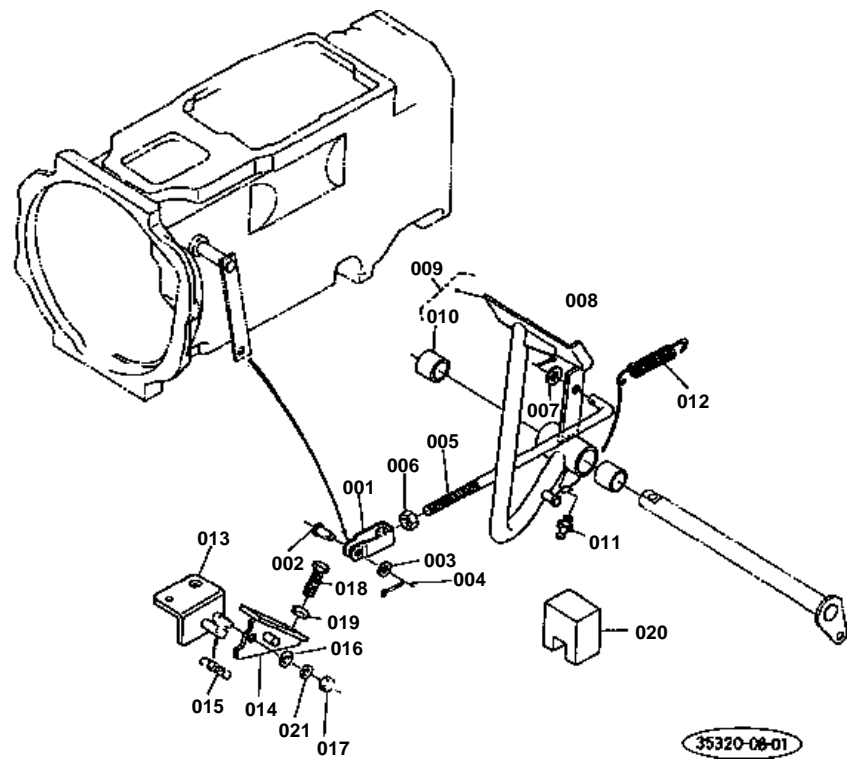



## CLUTCH PEDAL

↔ Interchangeable; ≠ not interchangeable; ← new for old; → old for new

REF.No	Part No.	Description	Q'ty	S.No.	I/C	REMARKS	Weight (kgf)	Weight (lb)
001	34150-15630	JOINT FORKED	1				0.095	0.209
002	05122-50822	PIN JOINT	1				0.01	0.022
003	04012-50080	WASHER PLAIN	1				0.001	0.0022
004	05511-50218	PIN SPLIT	1				0.001	0.0022
005	35340-15640	ROD CLUTCH	1				0.21	0.462
006	02172-50120	NUT	1				0.01	0.022
007	04013-50120	WASHER PLAIN	1				0	0
008	05511-50425	PIN SPLIT	1				0.003	0.0066
009	35340-15710	PEDAL CLUTCH	1				1.62	3.564
010	34150-28430	BUSH	2				0.04	0.088
011	06613-10675	NIPPLE GREASE	1				0.003	0.0066
012	37150-15840	SPRING	1				0.06	0.132
013	35350-15750	BRACKET CLUTCH STOPP	1				0.245	0.539
014	35340-15760	STOPPER CLUTCH	1				0.175	0.385
015	34370-15770	SPRING	1				0.004	0.0088
016	04013-50080	WASHER PLAIN	1				0	0
017	02114-50080	NUT	1				0.005	0.011
018	01170-51030	BOLT	1				0	0
019	02116-50100	NUT	1				0.004	0.0088
020	35340-15950	PIECE DISTANCE	1				0.04	0.088
021	04512-50080	WASHER SPRING	1				0	0

# STEERING

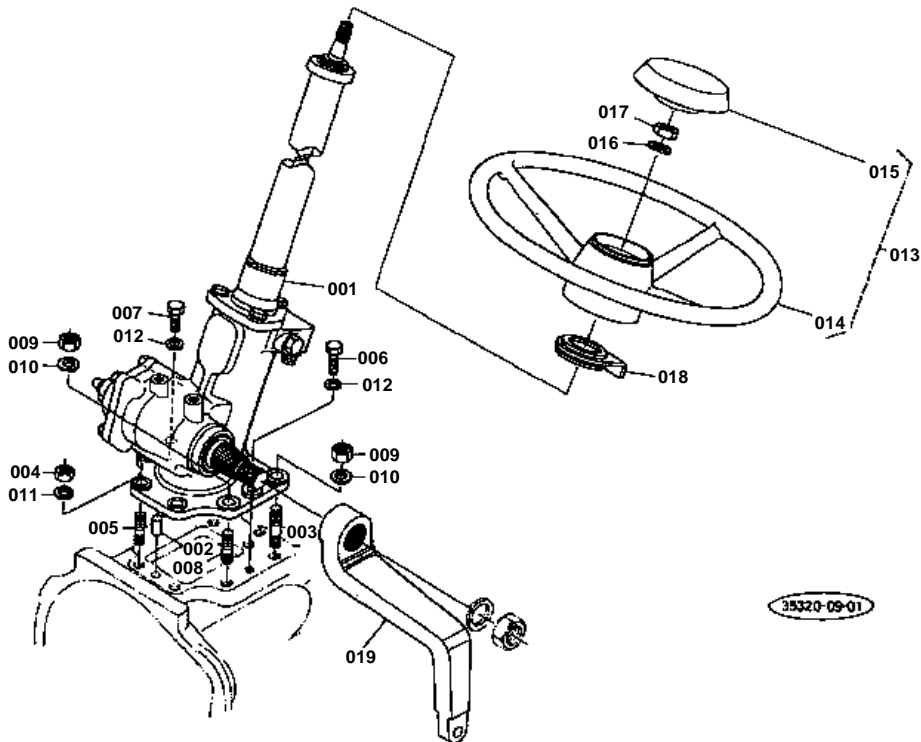

REF. No. 38180-1680-0  
38180-1681-0  
37150-1682-0

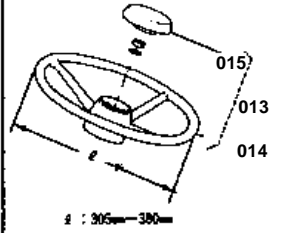

38320-09-01

**STEERING**

↔ Interchangeable; ≠ not interchangeable; ← new for old; → old for new

REF.No	Part No.	Description	Q'ty	S.No.	I/C	REMARKS	Weight (kgf)	Weight (lb)
001	35350-16100	ASSY POWER STEERING	1				0	0
001	35340-16104	ASSY POWER STEERING	1	>=10001			0	0
002	37150-27370	PIN STRAIGHT	2				0.009	0.0198
003	01574-51240	STUD	2				0	0
004	02118-50100	NUT	2				0.005	0.011
005	01517-51028	STUD	2				0.022	0.0484
006	01153-50835	BOLT	1				0.016	0.0352
007	01153-50830	BOLT	1				0	0
008	01574-51228	STUD	2				0.035	0.077
009	02174-50120	NUT	4				0.01	0.022
010	04512-50120	WASHER SPRING	4				0	0
011	04512-50100	WASHER SPRING	2				0	0
012	04512-50080	WASHER SPRING	2				0	0
013	38180-16800	ASSY HANDLE STEERING	1				0.24	0.528
013	66611-41400	ASSY HANDLE STEERING	1	>=10001			0	0
014	38180-16810	HANDLE STEERING	1				0	0
014	99999-99999	HANDLE STEERING	1	>=10001		ORDER BY REF.No.013	0	0
015	37150-16820	CAP HANDLE	1				0.026	0.0572
015	66611-41420	CAP HANDLE	1	>=10001			0.026	0.0572
016	04512-50120	WASHER SPRING	1				0	0
017	02174-50120	NUT	1				0.01	0.022
018	37300-16850	HOLDER POST	1				0.025	0.055
019	35350-43930	ARM PITMAN	1				2.94	6.468



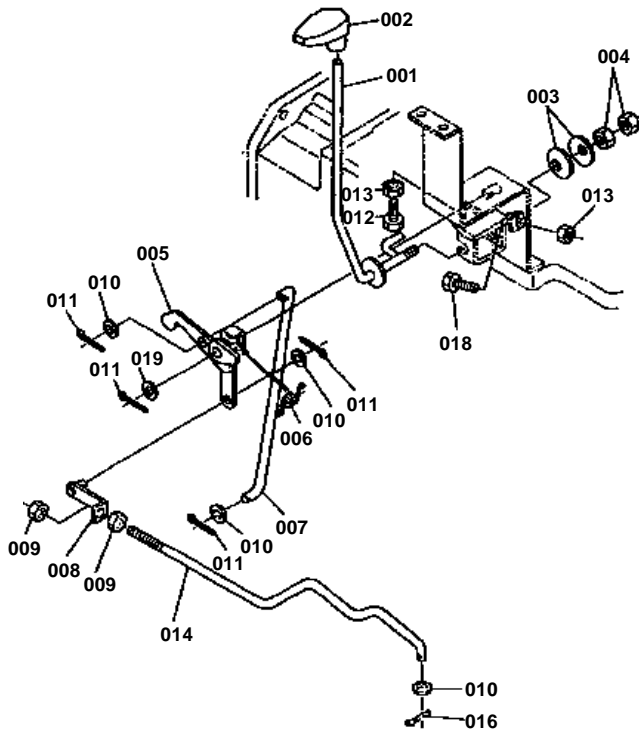

35320-10-03

- REF. No. ① 35320 - 1712 - 0  
② 34220 - 1719 - 0  
③ 02118 - 50100  
④ 35320 - 1732 - 0  
⑤ 35320 - 1725 - 3  
⑥ 35320 - 1757 - 0  
⑦ 02112 - 50080  
⑧ 35320 - 1736 - 0  
⑨ 02116 - 50100  
⑩ 04014 - 50140

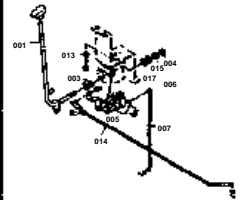

**HAND ACCEL**

↔ Interchangeable; ≠ not interchangeable; ← new for old; → old for new

REF.No	Part No.	Description	Q'ty	S.No.	I/C	REMARKS	Weight (kgf)	Weight (lb)
001	35320-17120	LEVER HAND ACCEL	1	↔=10316			0.355	0.781
001	35170-17120	LEVER HAND ACCEL	1	≧=10317			0.345	0.759
002	35320-17170	GRIP ACCEL	1				0.018	0.0396
003	34260-17190	SPRING	4	↔=10316			0.002	0.0044
003	34260-17190	SPRING	2	↔=10317			0.002	0.0044
004	02118-50100	NUT	1	↔=10316			0.005	0.011
004	02118-50100	NUT	2	≧=10317			0.005	0.011
005	35320-17324	LINK ACCEL	1	↔=10316			0.315	0.693
005	35170-17320	LINK ACCEL	1	≧=10317			0.12	0.264
006	35320-17260	SPRING	1	↔=10101			0	0
006	35320-17263	SPRING	1	≧=10001			0.02	0.044
006	34150-17260	SPRING	1	≧=10317			0.01	0.022
007	35320-17570	ROD ACCEL	1	↔=10316			0.08	0.176
007	37300-17570	ROD ACCEL	1	≧=10317			0.075	0.165
008	34150-17390	JOINT ROD	1				0.025	0.055
009	02012-50060	NUT	2				0	0
010	04012-50060	WASHER PLAIN	5				0.001	0.0022
011	05511-50520	PIN SPLIT	5				0.006	0.0132
012	01152-50830	BOLT	1				0.014	0.0308
013	02112-50080	NUT	1	↔=10316			0.003	0.0066
013	02112-50080	NUT	2	≧=10317			0.003	0.0066
014	35320-17360	ROD ACCEL 3	1	↔=10316			0.155	0.341
014	35320-17363	ROD ACCEL 3	1	≧=10317			0.17	0.374
015	02116-50100	NUT	1				0.004	0.0088
016	05511-51612	PIN SPLIT	1				0.001	0.0022
017	04014-50140	WASHER PLAIN	1				0.012	0.0264
018	01152-50840	BOLT	1	≧=10317			0	0
019	04012-50080	WASHER PLAIN	1	≧=10317			0.001	0.0022

# HOOD

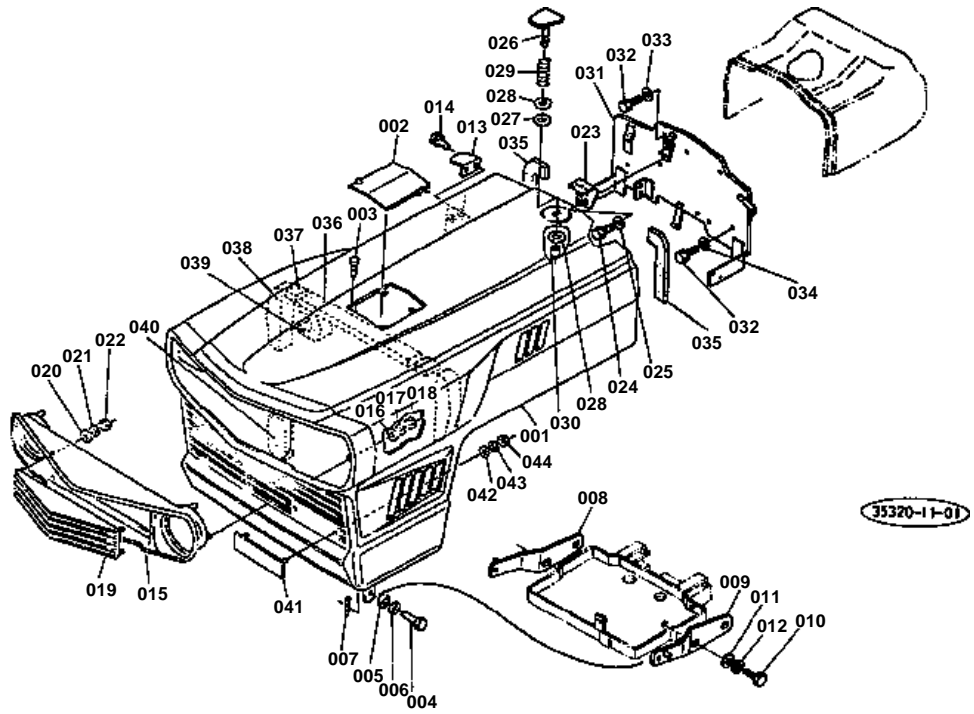



## HOOD

↔ Interchangeable; ≠ not interchangeable; ← new for old; → old for new

REF.No	Part No.	Description	Q'ty	S.No.	I/C	REMARKS	Weight (kgf)	Weight (lb)
001	35320-18110	ASSY BONNET	1				22	48.4
002	37300-18120	COVER BONNET	1				0.225	0.495
003	32280-18180	CUTHION	2				0.001	0.0022
004	34150-18170	BOLT	2				0.04	0.088
005	34150-18180	CUSHION	2				0.003	0.0066
006	04013-50120	WASHER PLAIN	2				0	0
007	05511-50425	PIN SPLIT	2				0.003	0.0066
008	35300-18120	SUPPORT BONNET RH	1				0.69	1.518
009	35300-18130	SUPPORT BONNET LH	1				0.89	1.958
010	01170-51230	BOLT	4				0	0
011	04015-50120	WASHER PLAIN	4				0	0
012	04512-50120	WASHER SPRING	4				0	0
013	37300-18170	HOOK	1				0.06	0.132
014	01202-50616	BOLT	2				0.006	0.0132
015	34350-18150	GRILLE LAMP	1				0.91	2.002
016	04015-50050	WASHER PLAIN	4				0.004	0.0088
017	04512-50050	WASHER SPRING	4				0	0
018	02054-50050	NUT	4				0.002	0.0044
019	34350-18160	GRILLE LAMP	1				0.186	0.4092
020	04012-50060	WASHER PLAIN	4				0.001	0.0022
021	04512-50060	WASHER SPRING	4				0	0
022	02014-50060	NUT	4				0.003	0.0066
023	37300-18220	ASSY BONNET HOLDER	1				0.125	0.275
024	01120-50818	BOLT	2				0	0
025	04013-50080	WASHER PLAIN	2				0	0
026	33251-83460	PIN SUPPORT	1				0.045	0.099
027	04711-00100	GASKET	1				0.001	0.0022
028	04013-50100	WASHER PLAIN	2				0	0
029	34150-37740	SPRING	1				0.003	0.0066
030	33251-83480	SPACER	1				0.001	0.0022
031	37300-18060	PLATE BAFFLE	1				2.1	4.62
032	01120-50816	BOLT	3				0	0
033	04015-50080	WASHER PLAIN	1				0	0
034	04012-50080	WASHER PLAIN	2				0.001	0.0022
035	34260-18070	CUSHION	2				0	0
036	37300-18020	CUSHION 1	1				0.02	0.044
037	37300-18030	CUSHION 2	2				0.002	0.0044
038	37300-18040	CUSHION	2				0.015	0.033
039	37300-18080	CUSHION	1				0.01	0.022
040	37300-18090	CUSHION	1				0.005	0.011
041	32240-18260	MARK FRONT KUBOTA	1				0.027	0.0594
042	04013-50050	WASHER PLAIN	2				0	0
043	04512-50050	WASHER SPRING	2				0	0
044	02054-50050	NUT	2				0.002	0.0044

# HEAD LAMP

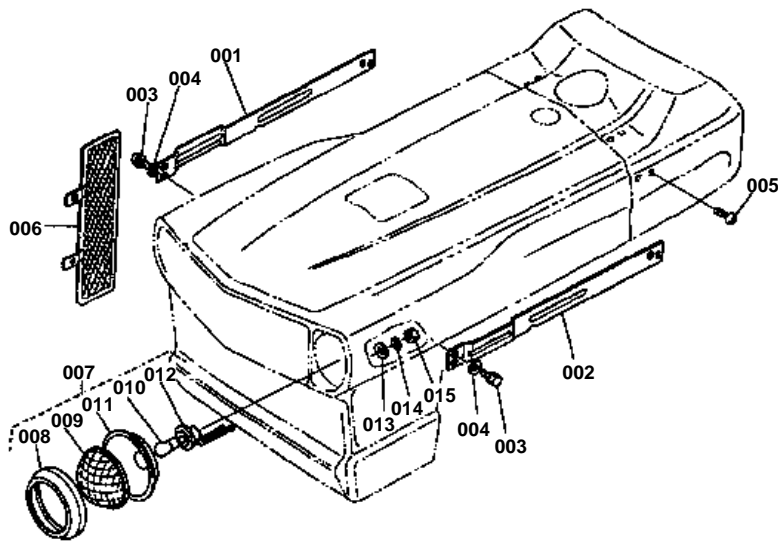

35320-12-01

REF. No. 34200-3420-0  
34220-3421-0  
34200-3412-0

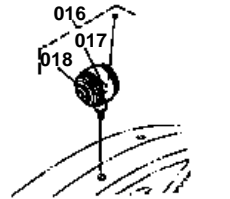

**HEAD LAMP**

↔ Interchangeable; ≠ not interchangeable; ← new for old; → old for new

REF.No	Part No.	Description	Q'ty	S.No.	I/C	REMARKS	Weight (kgf)	Weight (lb)
001	35320-13550	FRAME UPPER 1	1				0.8	1.76
002	35320-13560	FRAME UPPER 2	1				0.82	1.804
003	01120-50818	BOLT	8				0	0
004	04013-50080	WASHER PLAIN	8				0	0
005	03004-50812	SCREW	8				0.008	0.0176
006	35300-13850	COVER BELT RH	1				0.38	0.836
007	32240-33800	ASSY LAMP HEAD	2				0.33	0.726
008	32240-33810	BODY	2				0.06	0.132
009	32280-33830	LENS	2				0.098	0.2156
010	32150-33840	LAMP	2				0.014	0.0308
011	32240-33870	REFLECTOR	2				0.135	0.297
012	32280-33850	RUBBER	2				0.005	0.011
013	04013-50050	WASHER PLAIN	6				0	0
014	04512-50050	WASHER SPRING	6				0	0
015	02054-50050	NUT	6				0.002	0.0044
016	34260-34200	ASSY LAMP WINKER	2	≤10316		U.S.A.	0.2	0.44
017	34220-34210	BULB LAMP	2	≤10316		U.S.A.	0.008	0.0176
018	34260-34120	LENS	4	≤10316		U.S.A.	0.022	0.0484

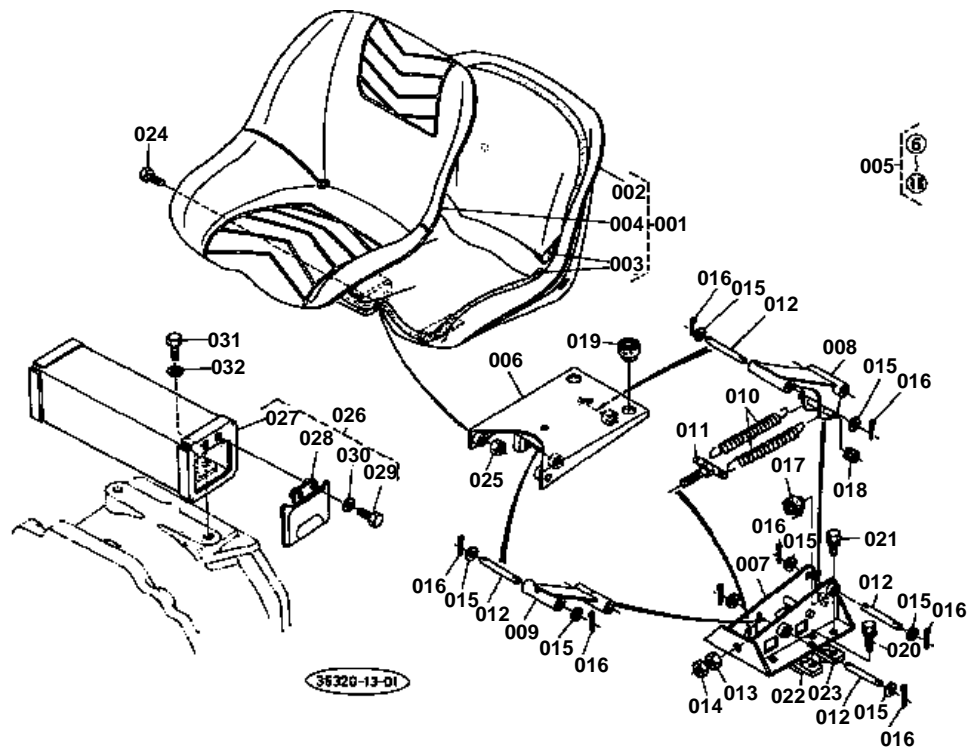



## SEAT

↔ Interchangeable; ≠ not interchangeable; ← new for old; → old for new

REF.No	Part No.	Description	Q'ty	S.No.	I/C	REMARKS	Weight (kgf)	Weight (lb)
001	35110-85010	ASSY SEAT	1				0	0
002	99999-99999	BLANK	0			ORDER BY REF.No.001	0	0
003	99999-99999	BLANK	0			ORDER BY REF.No.001	0	0
004	99999-99999	BLANK	0			ORDER BY REF.No.001	0	0
005	35110-18400	ASSY SUSPENSION SEAT	1				4.3	9.46
006	99999-99999	BLANK	0			ORDER BY REF.No.005	0	0
007	99999-99999	BLANK	0			ORDER BY REF.No.005	0	0
008	35258-18430	ARM 1	1				0.67	1.474
009	99999-99999	BLANK	0			ORDER BY REF.No.005	0	0
010	34119-18450	SPRING SEAT	2				0.117	0.2574
011	35258-18460	BOLT ADJUSTING	1				0.08	0.176
012	34269-18490	PIN	4				0.06	0.132
013	02118-50100	NUT	1				0.005	0.011
014	02116-50100	NUT	1				0.004	0.0088
015	04013-50100	WASHER PLAIN	8				0	0
016	05511-50220	PIN SPLIT	8				0.001	0.0022
017	32160-18440	CUSHION	1				0.013	0.0286
018	35258-18480	ROLLER	2				0.005	0.011
019	32160-18440	CUSHION	2				0.013	0.0286
020	01130-51020	BOLT	6				0	0
021	01130-51038	BOLT	2				0	0
022	35300-18460	SEAT SPACER FRONT	1				0.37	0.814
023	35300-18470	SEAT SPACER REAR	1				0.53	1.166
024	35110-18470	BOLT	2				0.012	0.0264
025	02114-50080	NUT	2				0.005	0.011
026	35340-18510	ASSY BOX TOOLS	1				3.05	6.71
027	35340-18520	BOX TOOLS	1				1.5	3.3
028	66571-54520	CAP SID	1				0.085	0.187
029	01053-50614	BOLT	2				0.005	0.011
030	04512-50060	WASHER SPRING	2				0	0
031	01173-51225	BOLT	2				0.033	0.0726
032	04512-50120	WASHER SPRING	2				0	0



# TRANSMISSION CASE

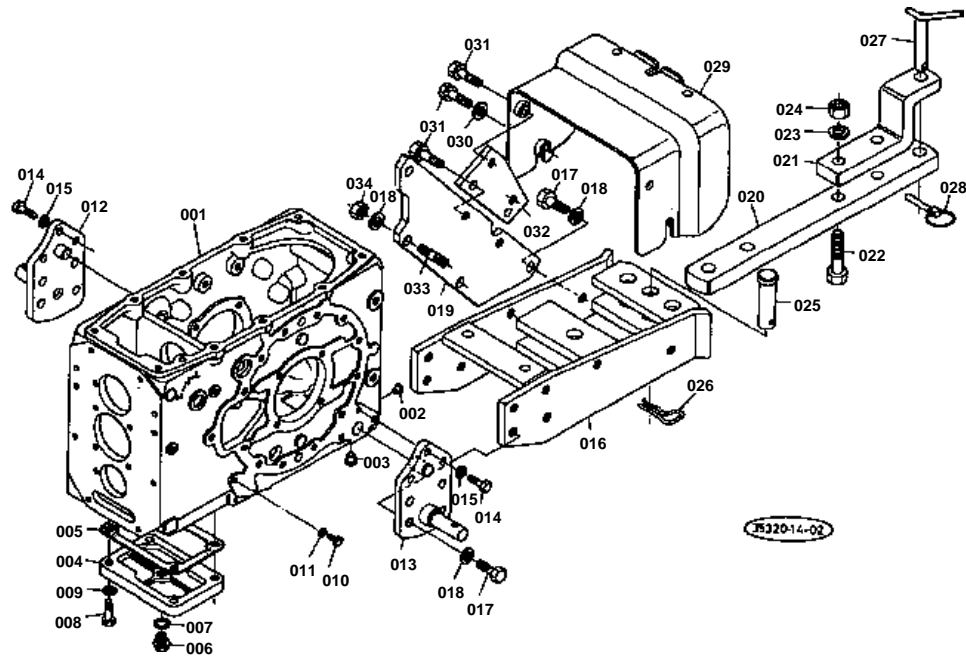



TRANSMISSION CASE

↔ Interchangeable; ≠ not interchangeable; ← new for old; → old for new

REF.No	Part No.	Description	Q'ty	S.No.	I/C	REMARKS	Weight (kgf)	Weight (lb)
001	35340-21113	CASE TRANSMISSION	1				0	0
002	32210-27580	PLUG	10				0.001	0.0022
003	31220-14290	PLUG	6				0.002	0.0044
004	37150-21270	COVER	1				3.6	7.92
005	37150-21282	GASKET	1				0	0
006	34150-14260	PLUG DRAIN	1				0	0
007	04717-02150	WASHER SEAL	1				0.004	0.0088
008	01173-51235	BOLT	4				0.04	0.088
009	04512-50120	WASHER SPRING	4				0	0
010	01222-50816	BOLT	1				0.01	0.022
011	04512-50080	WASHER SPRING	1				0	0
012	37300-71220	BRACKET LOWER LINK R	1				1.4	3.08
013	37300-71230	BRACKET LOWER LINK L	1				1.5	3.3
014	01176-51232	BOLT	6				0.041	0.0902
015	04512-50120	WASHER SPRING	6				0	0
016	35320-29710	FRAME DRAWBAR	1	>=10102			11.2	24.64
017	01173-51430	BOLT	14				0.052	0.1144
018	04512-50140	WASHER SPRING	18				0	0
019	35320-29720	LINKL SUPPORT	2	>=10102			4	8.8
020	99553-78210	DRAWBAR 1	1				5.84	12.848
021	99533-78240	DRAWBAR 2	1			EXCEPT U.S.A.	2.22	4.884
022	01170-51665	BOLT	2			EXCEPT U.S.A.	0	0
023	04512-50160	WASHER SPRING	2			EXCEPT U.S.A.	0	0
024	02174-50160	NUT	2				0.022	0.0484
025	37300-29780	PIN JOINT	3				0.31	0.682
026	37300-29790	PIN SPRING	3				0	0
026	70515-16330	PIN SPRING	3	>=10001			0.028	0.0616
027	99533-78250	PIN	1			EXCEPT U.S.A.	0.61	1.342
028	34150-37640	PIN SET	1			EXCEPT U.S.A.	0.06	0.132
029	35320-25330	PROTECTOR SHAFT (PTO	1	>=10102			5.4	11.88
030	04013-50100	WASHER PLAIN	2				0	0
031	01133-51025	BOLT	8				0.023	0.0506
032	35320-25440	SUPPORT PTO PROTECTO	2	>=10102			0.75	1.65
033	01517-51428	STUD	4				0.05	0.11
034	02174-50140	NUT	4				0.014	0.0308

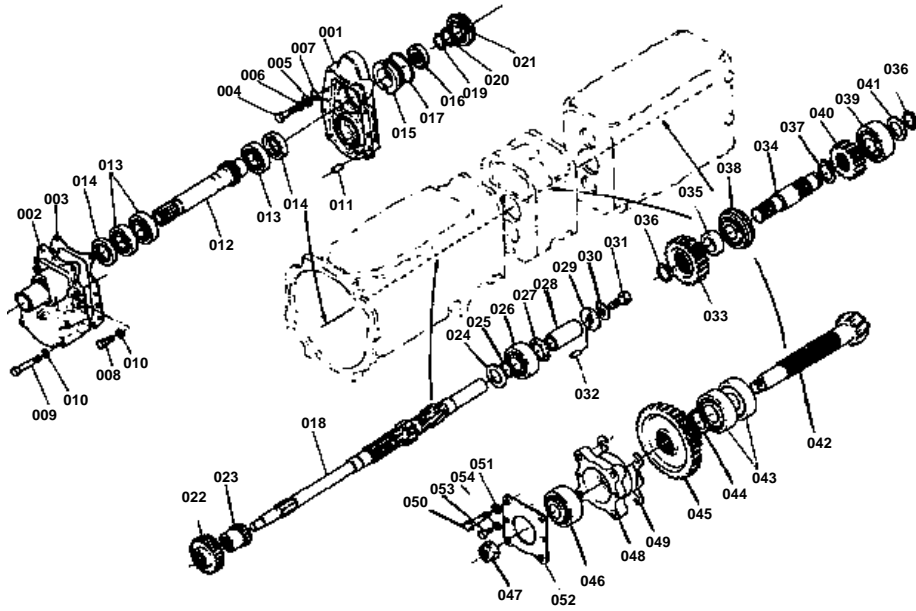

REF. No. 35340-2153-0  
GEAR 25



REF. No. 35340-2153-2  
GEAR 24



## TRANSMISSION 1

↔ Interchangeable; ≠ not interchangeable; ← new for old; → old for new

REF.No	Part No.	Description	Q'ty	S.No.	I/C	REMARKS	Weight (kgf)	Weight (lb)
001	35340-21310	CASE GEAR	1				2.78	6.116
002	35340-21320	COVER GEAR CASE	1				2.87	6.314
003	35340-21330	GASKET	1				0	0
004	35340-21340	BOLT	4				0.03	0.066
005	35340-21360	WASHER	4				0.01	0.022
006	04512-50100	WASHER SPRING	4				0	0
007	04811-00100	O RING	4				0.001	0.0022
008	01123-50825	BOLT	4				0.013	0.0286
009	01153-50850	BOLT	4				0.02	0.044
010	04512-50080	WASHER SPRING	4				0	0
011	05012-00818	PIN STRAIGHT	2				0.008	0.0176
012	35340-21350	SHAFT GEAR 16	1				0.935	2.057
013	08101-06007	BEARING BALL	3				0.16	0.352
014	09503-55508	SEAL OIL	2				0	0
015	35340-15420	SPACER 1	1				0.275	0.605
016	09502-55210	SEAL OIL	1				0.025	0.055
017	04811-50650	O RING	1				0.002	0.0044
018	35340-21510	SHAFT MAIN	1				2.5	5.5
019	37150-21550	CIR-CLIP EXTERNAL	1				0.06	0.132
020	34150-21560	WASHER	1				0.01	0.022
021	08150-00003	BEARIANG BALL	1				0.25	0.55
022	35340-21530	GGEAR 25	1	<=10206			0.405	0.891
022	35340-21532	GGEAR 24	1	>=10207			0.405	0.891
023	37150-21520	GEAR 17	1				0.225	0.495
024	37150-21590	COLLAR	1				0.025	0.055
025	04612-00300	CIR-CLIP EXTERNAL	1				0.003	0.0066
026	08241-03206	BEARING BALL	1				0.302	0.6644
027	37300-21580	COLLAR	1				0.015	0.033
028	35300-21570	COLLAR	1				0	0
028	35300-21572	COLLAR	1	>=10001			0.23	0.506
029	34260-21590	WASHER	1				0.04	0.088
030	38180-22370	WASHER CLAW	1				0.005	0.011
031	34260-26260	BOLT	1				0.03	0.066
032	05012-00310	PIN STRAIGHT	1				0.001	0.0022
033	35340-25280	GEAR 21	1				0.7	1.54
034	35340-25290	PTO GEAR	1				0.955	2.101
035	35340-25210	COLLAR	1				0.06	0.132
036	04612-00300	CIR-CLIP EXTERNAL	2				0.003	0.0066
037	04612-00350	CIR-CLIP EXTERNAL	1				0.01	0.022
038	08150-00006	BEARING BALL	1				0	0
039	08100-00022	BEARING BALL	1				0.37	0.814
040	35340-25230	GEAR 15	1				0.332	0.7304
041	35340-21760	COLLAR THRUST	1				0.01	0.022
042	99999-99999	BLANK	0			ORDER BY REF.No.021 ON FIG.T040	0	0
043	08641-00306	BEARING ROLLER	2				0.37	0.814
044	04612-00300	CIR-CLIP EXTERNAL	1				0.003	0.0066
045	35300-21950	GEAR 15-37	1				1.24	2.728
046	38240-22140	BEARING ROLLER	1				0.56	1.232
047	31220-22340	NUT 22	1				0.033	0.0726
048	37300-22150	CASE BEARIANG	1				0.56	1.232
049	34150-22610	SHIM 0.5	2				0.01	0.022
049	34150-22620	SHIM 0.2	4				0.005	0.011
049	34150-22630	SHIM 0.1	2				0.005	0.011
050	01173-51035	BOLT	4				0.025	0.055
051	04512-50100	WASHER SPRING	4				0	0
052	34150-22170	COVER BEARING	1				0.16	0.352
053	01153-50816	BOLT	2				0.01	0.022
054	04512-50080	WASHER SPRING	2				0	0

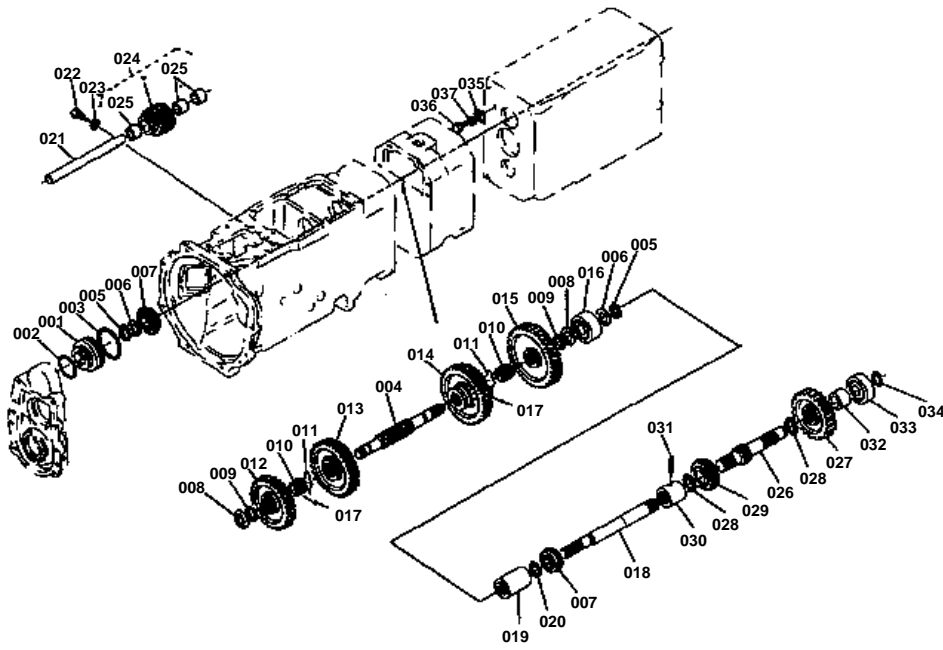

REF. No. 35340-2171-0  
GEAR 30



REF. No. 35340-2171-2  
GEAR 31

**TRANSMISSION 2**

↔ Interchangeable; ≠ not interchangeable; ← new for old; → old for new

REF.No	Part No.	Description	Q'ty	S.No.	I/C	REMARKS	Weight (kgf)	Weight (lb)
001	35340-21390	SPACER 3	1				0.235	0.517
002	04811-50550	O RING	1				0.002	0.0044
003	04811-50400	O RING	1				0.002	0.0044
004	35300-21610	SHAFT COUNTER	1				1.115	2.453
005	37150-21550	CIR-CLIP EXTERNAL	2				0.06	0.132
006	34150-21560	WASHER	2				0.01	0.022
007	08151-06205	BEARING BALL	2				0.131	0.2882
008	37150-21760	COLLAR THRUST	2				0.017	0.0374
009	37150-21790	RING SET	2				0.001	0.0022
010	37150-21750	BOSS SPLINE	2				0.088	0.1936
011	35340-21780	CIR-CLIP	2				0	0
011	35340-21782	CIR-CLIP	2	≥10001			0.007	0.0154
012	35340-21710	GEAR 30	1	≤10206			0.47	1.034
012	35340-21712	GEAR 31	1	≥10207			0.535	1.177
013	37150-21720	GEAR 41	1				0.77	1.694
014	37150-21730	GEAR 45	1				0.945	2.079
015	37150-21740	GEAR 45	1				1.08	2.376
016	08241-03205	BEARING BALL	1				0	0
017	35340-21792	WIRE	2				0.001	0.0022
017	35340-21792	WIRE	2	≥10001			0.001	0.0022
018	35340-21810	SHAFT CREEP CHANGE	1				1.43	3.146
019	35300-21660	COUPLING	1				0.19	0.418
020	37150-21550	CIR-CLIP EXTERNAL	1				0.06	0.132
021	37300-23110	SHAFT REVERSE	1				0.47	1.034
022	37150-23120	SCREW SET	1				0.02	0.044
023	04717-00800	WASHER SEAL	1				0.001	0.0022
024	37150-23100	ASSY GEAR 22	1				0.885	1.947
025	31220-26360	BUSH	3				0.015	0.033
026	35300-21910	SHAFT GEAR 12	1				0.94	2.068
027	35300-21920	GEAR 21	1				0.61	1.342
028	04612-00300	CIR-CLIP EXTERNAL	2				0.003	0.0066
029	08151-06206	BEARING BALL	1				0.2	0.44
030	37300-21680	COUPLING	1				0.28	0.616
031	05411-00540	PIN SPRING	1				0.004	0.0088
032	37300-21940	COLLAR DISTANCE	1				0.055	0.121
033	08101-06305	BEARING BALL	1				0.23	0.506
034	37150-21550	CIR-CLIP EXTERNAL	1				0.06	0.132
035	34150-21940	RETAINER BEARING	1				0	0
036	01153-50820	BOLT	1				0.012	0.0264
037	04512-50080	WASHER SPRING	1				0	0

# TRANSMISSION 3

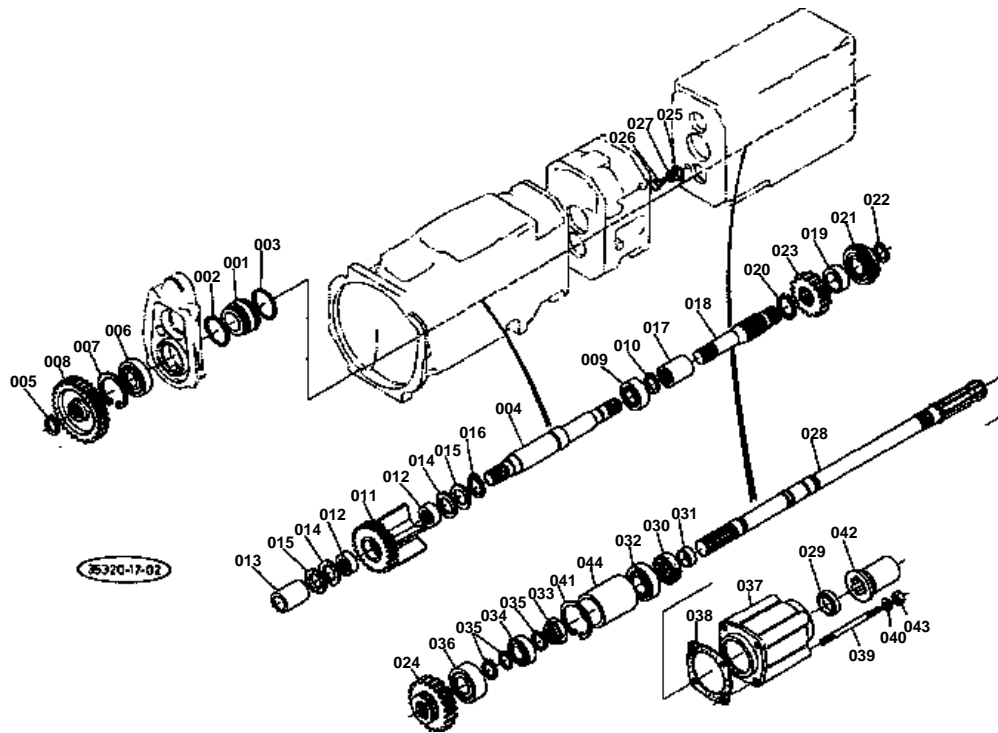

**TRANSMISSION 3**

↔ Interchangeable; ≠ not interchangeable; ← new for old; → old for new

REF.No	Part No.	Description	Q'ty	S.No.	I/C	REMARKS	Weight (kgf)	Weight (lb)
001	35340-21380	SPACER 2	1				0.22	0.484
002	04811-50500	O RING	1				0.001	0.0022
003	04811-50550	O RING	1				0.002	0.0044
004	35340-25330	SHAFT COUNTER (PTO)	1				1.47	3.234
005	37150-21550	CIR-CLIP EXTERNAL	1				0.06	0.132
006	08100-00031	BEARING BALL	1				0.242	0.5324
007	04611-00620	CIR-CLIP INTERNAL	1				0.011	0.0242
008	35340-25340	GEAR 39	1				0.82	1.804
009	08101-06205	BEARING BALL	1				0.14	0.308
010	37150-21550	CIR-CLIP EXTERNAL	1				0.06	0.132
011	35340-21720	GEAR 30	1				1.07	2.354
012	08813-03712	BEARING NEEDLE	2				0.023	0.0506
013	35340-21770	COLLAR DISTANCE	1				0.15	0.33
014	35340-21560	WASHER	2				0.008	0.0176
015	35340-21760	COLLAR THRUST	2				0.01	0.022
016	04612-00300	CIR-CLIP EXTERNAL	1				0.003	0.0066
017	37150-21680	COUPLING	1				0	0
018	35340-25250	SHAFT COUNTER (PTO)	1				0.885	1.947
019	35340-25260	COLLAR	1				0.043	0.0946
020	04612-00350	CIR-CLIP EXTERNAL	1				0.01	0.022
021	08150-00008	BEARING BALL	1				0.225	0.495
022	04612-00300	CIR-CLIP EXTERNAL	1				0.003	0.0066
023	35340-25270	GEAR 16	1				0.37	0.814
024	35340-25450	GEAR 22	1				0.818	1.7996
025	34150-21940	RETAINER BEARING	2				0	0
026	01153-50820	BOLT	2				0.012	0.0264
027	04512-50080	WASHER SPRING	2				0	0
028	35320-25310	SHAFT (PTO)	1	≥10102			4	8.8
029	37150-25370	SLIDINGER	1				0.007	0.0154
030	35340-25360	SEAL OIL	1				0.024	0.0528
031	35340-25350	COLLAR OIL SEAL	1				0.03	0.066
032	08101-06232	BEARING BALL	1				0.22	0.484
033	35340-25320	NUT	1				0.05	0.11
034	35340-25380	BEARING ROLLER	1				0.175	0.385
035	04612-00300	CIR-CLIP EXTERNAL	4				0.003	0.0066
036	08241-03206	BEARING BALL	1				0.302	0.6644
037	35320-25410	CASE BEARIANG	1	≥10102			3.5	7.7
038	37150-25420	GASKET	1				0	0
039	35320-25430	STUD	4	≥10102			0.05	0.11
040	04512-50080	WASHER SPRING	4				0	0
041	04611-00650	CIR-CLIP INTERNAL	1				0.011	0.0242
042	31220-25820	CAP	1				0.055	0.121
043	35320-25470	NUT	4	≥10102			0.006	0.0132
044	35320-25380	COLLAR	1	≥10102			0.58	1.276



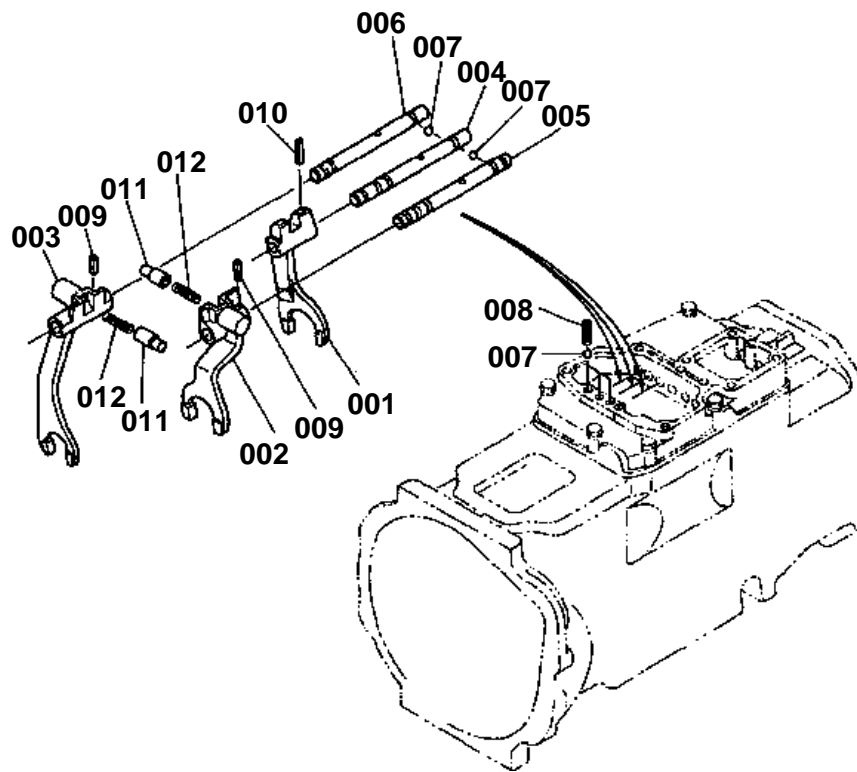



## SPEED CHANGE SYSTEM 1

↔ Interchangeable; ≠ not interchangeable; ← new for old; → old for new

REF.No	Part No.	Description	Q'ty	S.No.	I/C	REMARKS	Weight (kgf)	Weight (lb)
001	35305-23510	FORK SHIFT	1				0.19	0.418
002	35305-23520	FORK SHIFT	1				0.28	0.616
003	35305-23530	FORK SHIFT	1				0.29	0.638
004	37150-23540	ROD FORK	1				0.12	0.264
005	37150-23550	ROD FORK	1				0.12	0.264
006	37150-23570	ROD FORK	1				0.32	0.704
007	07715-01605	BALL	5				0.003	0.0066
008	62231-18530	SPRING STOPPER	3				0.01	0.022
009	05411-00420	PIN SPRING	2				0.001	0.0022
010	05411-00430	PIN SPRING	1				0.002	0.0044
011	34150-23610	PIECE NEUTRAL	2				0.015	0.033
012	34150-23620	SPRING	2				0.003	0.0066

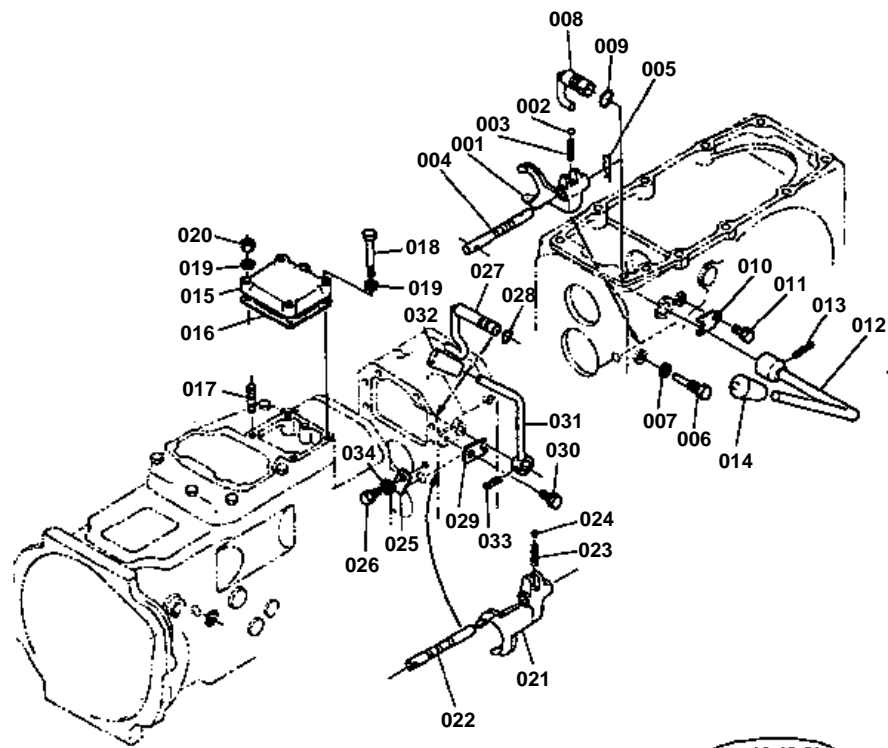



**SPEED CHANGE SYSTEM 2**

↔ Interchangeable; ≠ not interchangeable; ← new for old; → old for new

REF.No	Part No.	Description	Q'ty	S.No.	I/C	REMARKS	Weight (kgf)	Weight (lb)
001	35300-24110	FORK SHIFT	1				0.2	0.44
002	07715-01605	BALL	1				0.003	0.0066
003	62231-18530	SPRING STOPPER	1				0.01	0.022
004	37150-24130	SHAFT FORK	1				0.11	0.242
005	05515-51200	PIN SNAP	1				0	0
006	37150-23120	SCREW SET	1				0.02	0.044
007	04717-00800	WASHER SEAL	1				0.001	0.0022
008	37300-24310	LEVER SHIFT	1				0	0
008	37150-24310	LEVER SHIFT	1	>=10001			0.145	0.319
009	04811-00150	O RING	1				0.001	0.0022
010	34150-24350	STOPPER LEVER	1				0.015	0.033
011	01120-50816	BOLT	1				0	0
012	35320-24430	LEVER AUX S-CHANGE	1				0.395	0.869
013	05411-00632	PIN SPRING	1				0.004	0.0088
014	37300-24560	GRIP LEVER	1				0.02	0.044
015	35340-24830	COVER CREEP CHANGE	1				0.468	1.0296
016	34650-59330	GASKET	1				0	0
017	01513-50825	STUD	3				0	0
018	01153-50870	BOLT	2				0.026	0.0572
019	04512-50080	WASHER SPRING	5				0	0
020	02156-50080	NUT	3				0.004	0.0088
021	35340-25610	FORK SHIFT	1				0	0
022	35340-25620	SHAFT FORK	1				0.09	0.198
023	62231-18530	SPRING STOPPER	1				0.01	0.022
024	07715-01605	BALL	1				0.003	0.0066
025	35340-25560	RETAINER SHAFT 1	1				0.01	0.022
026	01123-50818	BOLT	1				0.012	0.0264
027	35340-25630	LEVER SHIFT	1				0.2	0.44
028	04811-00150	O RING	1				0.001	0.0022
029	35340-25640	RETAINER SHAFT 2	1				0.02	0.044
030	01120-50816	BOLT	1				0	0
031	35320-25650	LEVER CHANGE	1				0.3	0.66
032	37300-24560	CRIP LEVER	1				0.02	0.044
033	05541-100635	PIN SPRING	1				0	0
034	04015-50080	WASHER PLAIN	1				0	0

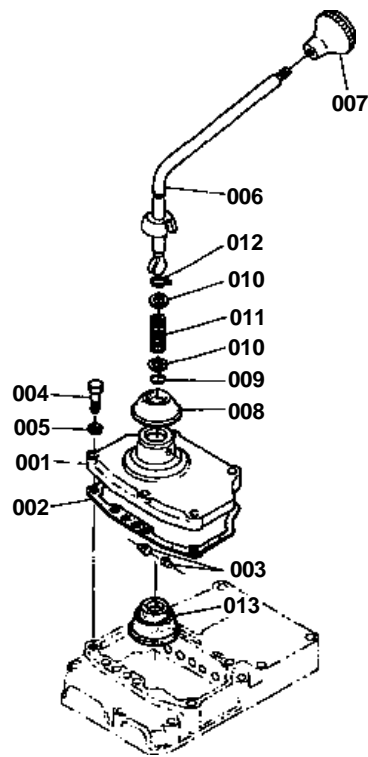



### SPEED CHANGE SYSTEM 3

↔ Interchangeable; ≠ not interchangeable; ← new for old; → old for new

REF.No	Part No.	Description	Q'ty	S.No.	I/C	REMARKS	Weight (kgf)	Weight (lb)
001	35340-23710	BASE SPEED CHANGE	1				1.46	3.212
002	34150-23720	GASKET	1				0	0
003	34150-23740	PIN SET	2				0.002	0.0044
004	01153-50832	BOLT	5				0.015	0.033
005	04512-50080	WASHER SPRING	5				0	0
006	34150-23810	LEVER MAIN S-CHANGE	1				0.43	0.946
007	32150-23860	GRIP LEVER	1				0.037	0.0814
008	34150-23940	SHIELD	1				0.025	0.055
009	04811-00120	O RING	1				0.001	0.0022
010	32240-23950	WASHER	2				0.002	0.0044
011	32240-23920	SPRING	1				0.007	0.0154
012	31220-23930	CIR-CLIP EXTERNAL	1				0.001	0.0022
013	34150-23870	SHIELD	1				0	0

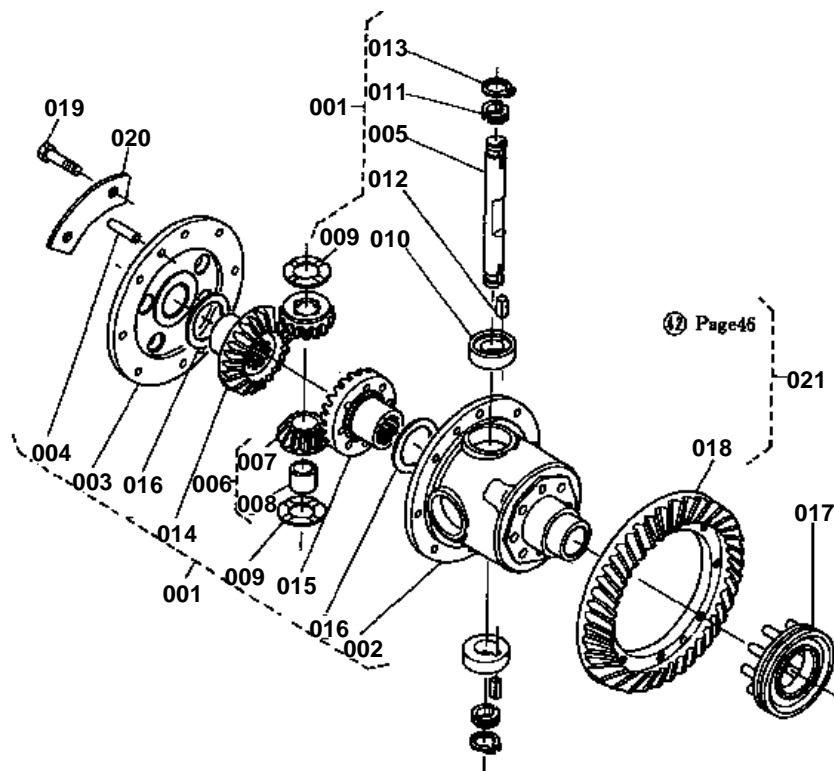



# DIFFERENTIAL SYSTEM 1

↔ Interchangeable; ≠ not interchangeable; ← new for old; → old for new

REF.No	Part No.	Description	Q'ty	S.No.	I/C	REMARKS	Weight (kgf)	Weight (lb)
001	37300-26100	ASSY DIFFERENTIAL	1				7	15.4
002	37300-26510	CASE DIFFERENTIAL	1				2.5	5.5
003	37300-26520	CAP DIFF CASE	1				1.35	2.97
004	37300-26530	PIN STRAIGHT	2				0.03	0.066
005	37300-26340	SHAFT DIFF PINION	2				0.27	0.594
006	37300-26310	ASSY PINION DIFFEREN	4				0.17	0.374
007	99999-99999	BLANK	0			ORDER BY REF.No.006	0	0
008	31220-26360	BUSH	4				0.015	0.033
009	37300-26390	WASHER DIFF PINION	4				0.02	0.044
010	37300-26370	BUSH	4				0.07	0.154
011	37300-26230	COLLAR SET 4.9	8				0.005	0.011
011	37300-26240	COLLAR SET 5.0	8				0.005	0.011
011	37300-26250	COLLAR SET 5.1	8				0.005	0.011
012	37300-26280	KEY	4				0.005	0.011
013	04612-00260	CIR-CLIP EXTERNAL	4				0.002	0.0044
014	37300-26430	GEAR DIFF BEARING RH	1				0.475	1.045
015	37300-26440	GEAR DIFF BEARING LH	1				0.63	1.386
016	37300-26480	WASHER DIFF SIDE GEA	2				0.015	0.033
016	37300-26490	WASHER DIFF SIDE GEA	2				0.015	0.033
017	37300-26610	SHIFTER DIFF LOCK	1				0.46	1.012
018	99999-99999	BLANK	0			ORDER BY REF.No.021	0	0
019	37300-26260	BOLT	8				0.305	0.671
020	37300-26270	WASHER	4				0.015	0.033
021	35300-22100	ASSY GEAR BEVEL	1				5.3	11.66



# DIFFERENTIAL SYSTEM 2

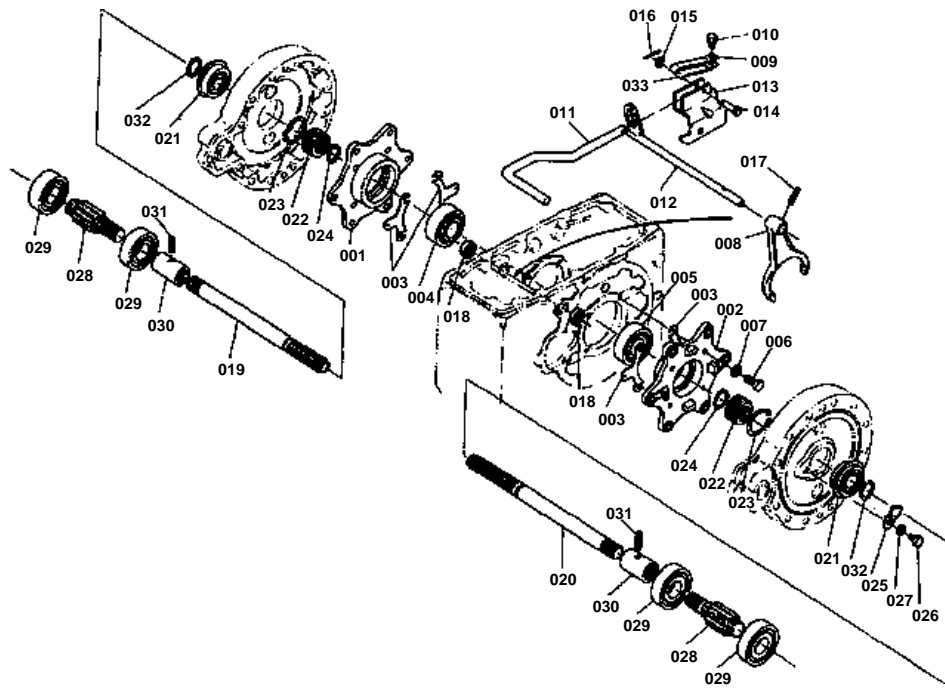



## DIFFERENTIAL SYSTEM 2

↔ Interchangeable; ≠ not interchangeable; ← new for old; → old for new

REF.No	Part No.	Description	Q'ty	S.No.	I/C	REMARKS	Weight (kgf)	Weight (lb)
001	37300-26550	CASE DIFF BEARING RH	1				0	0
002	37300-26560	CASE DIFF BEARING LH	1				0	0
003	37150-26160	SHIM 0.2	12				0.005	0.011
003	37150-26170	SHIM 0.1	8				0.005	0.011
003	37150-26180	SHIM 0.5	4				0.01	0.022
004	08711-32011	BEARING TAPER ROLLER	1				0.538	1.1836
005	08711-30209	BEARING TAPER ROLLER	1				0.458	1.0076
006	01173-51030	BOLT	8				0.023	0.0506
007	04512-50100	WASHER SPRING	8				0	0
008	37300-26630	FORK SHIFT	1				0.43	0.946
009	37150-26643	SPRING	1				0.033	0.0726
010	01120-50816	BOLT	1				0	0
011	37300-26650	PEDAL DIFF LOCK	1				0.635	1.397
012	37300-26680	CAM DIFF LOCK	1				0.252	0.5544
013	37300-26670	BRACKET PEDAL	1				0.655	1.441
014	05112-50835	PIN JOINT	1				0.016	0.0352
015	04012-50080	WASHER PLAIN	1				0.001	0.0022
016	05511-50218	PIN SPLIT	1				0.001	0.0022
017	05411-00630	PIN SPRING	1				0.004	0.0088
018	09500-16287	SEAL OIL	2				0.01	0.022
019	37300-26710	SHAFT RH	1				2.5	5.5
020	37300-26720	SHAFT LH	1				2.6	5.72
021	08151-06007	BEARING BALL	2				0.158	0.3476
022	37300-28190	BOSS SPLINE	2				0.105	0.231
023	04612-00450	CIR-CLIP EXTERNAL	2				0.007	0.0154
024	04612-00320	CIR-CLIP EXTERNAL	2				0.004	0.0088
025	34150-21940	RETAINER BEARING	2				0	0
026	01153-50818	BOLT	2				0.01	0.022
027	04512-50080	WASHER SPRING	2				0	0
028	37300-26750	SHAFT GEAR 11	2				1.095	2.409
029	08100-00026	BEARING BALL	4				0.495	1.089
030	37300-28180	COUPLING	2				0.28	0.616
031	05411-00545	PIN SPRING	2				0.004	0.0088
032	04612-00350	CIR-CLIP EXTERNAL	2				0.01	0.022
033	37150-26660	SPRING	1				0.025	0.055

REAR AXLE

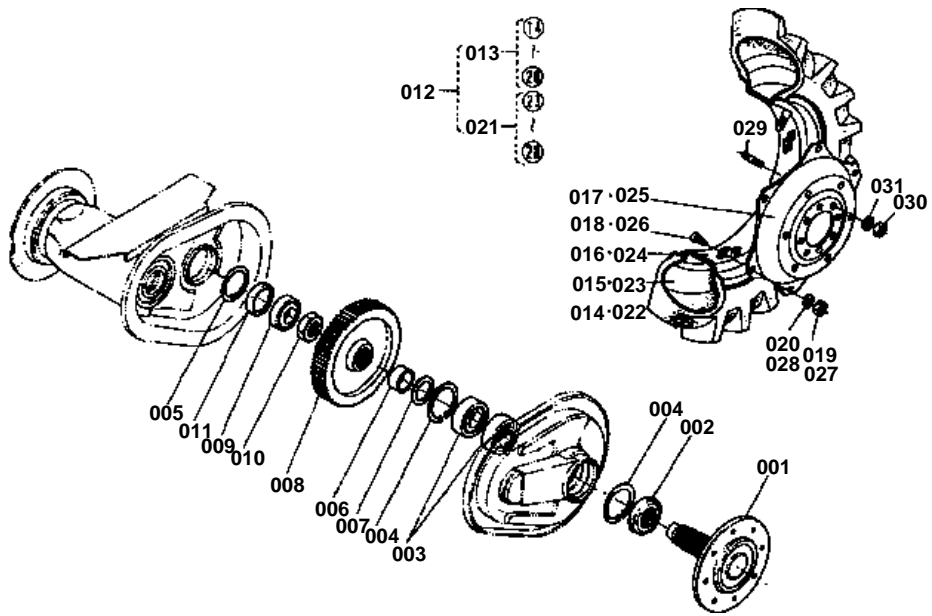



REAR AXLE

↔ Interchangeable; ≠ not interchangeable; ← new for old; → old for new

REF.No	Part No.	Description	Q'ty	S.No.	I/C	REMARKS	Weight (kgf)	Weight (lb)
001	35340-27110	AXLE REAR	2				12	26.4
002	37300-27560	SEAL OIL	2				0.172	0.3784
003	08101-06211	BEARING BALL	4				0.6	1.32
004	04611-01000	CIR-CLIP INTERNAL	4				0.042	0.0924
005	04611-00900	CIR-CLIP INTERNAL	2				0.031	0.0682
006	35340-27140	COLLAR	2				0.055	0.121
007	34350-27150	WASHER	2				0.015	0.033
008	37300-26830	GEAR 74	2				9.7	21.34
009	08100-00028	BEARING	2				0.67	1.474
010	37300-27280	NUT 50	2				0.135	0.297
011	37300-27290	PLUG	2				0.07	0.154
012	35320-27600	ASSY REAR WHEEL (12.	1				0	0
013	70000-00293	ASSY REAR WHEEL LH (	1			K.T.C.	0	0
013	35320-27610	ASSY REAR WHEEL LH (	1				0	0
014	70000-00308	TIRE	1			K.T.C.	0	0
014	37260-27620	TIRE	1				35	77
015	70000-00309	TUBE	1			K.T.C.	0	0
015	37260-27630	TUBE	1				0	0
016	70000-00294	RIM REAR	1			K.T.C.	0	0
016	37260-27640	RIM REAR	1				0	0
017	70000-00236	DISK	1			K.T.C.	0	0
017	35320-27660	DISK	1				14.5	31.9
018	70000-00010	BOLT	6			K.T.C.	0	0
018	31220-27680	BOLT	6				0.09	0.198
019	70000-00098	NUT	6			K.T.C.	0	0
019	02174-50160	NUT	6				0.022	0.0484
020	04512-50160	WASHER SPRING	6				0	0
021	70000-00292	ASSY REAR WHEEL RH (	1			K.T.C.	0	0
021	35320-27690	ASSY REAR WHEEL RH (	1				0	0
022	70000-00308	TIRE	1			K.T.C.	0	0
022	37260-27620	TIRE	1				35	77
023	70000-00309	TUBE	1			K.T.C.	0	0
023	37260-27630	TUBE	1				0	0
024	70000-00294	RIM REAR	1			K.T.C.	0	0
025	70000-00236	DISK	1			K.T.C.	0	0
025	35320-27660	DISK	1				14.5	31.9
026	70000-00010	BOLT	6			K.T.C.	0	0
026	31220-27680	BOLT	6				0.09	0.198
027	37260-27640	RIM REAR	1				0	0
027	70000-00098	NUT	6			K.T.C.	0	0
027	02174-50160	NUT	6				0.022	0.0484
028	04512-50160	WASHER SPRING	6				0	0
029	35410-49150	STUD	16				0.078	0.1716
030	36500-49390	NUT	16				0.043	0.0946
031	36500-49410	SPRING	16				0.024	0.0528

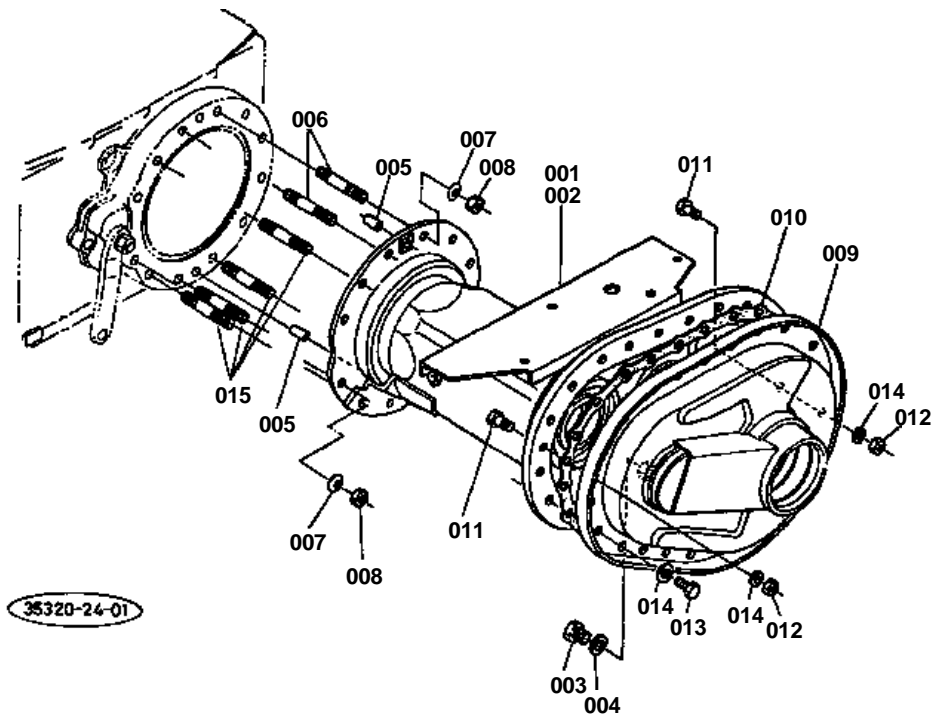

**AXLE CASE**

↔ Interchangeable; ≠ not interchangeable; ← new for old; → old for new

REF.No	Part No.	Description	Q'ty	S.No.	I/C	REMARKS	Weight (kgf)	Weight (lb)
001	35340-27310	CASE AXLE RH	1				0	0
002	35340-27320	CASE AXLE LH	1				23	50.6
003	06331-35016	PLUG	2				0.04	0.088
004	04717-01600	WASHER SEAL	2				0.003	0.0066
005	05012-01325	PIN STRAIGHT	4				0.028	0.0616
006	35340-27350	STUD	4				0.072	0.1584
007	35340-27370	WASHER	24				0.015	0.033
008	35340-27360	NUT	24				0.015	0.033
009	35340-27330	COVER AXLE CASE	2				9.3	20.46
010	37300-27340	GASKET	2				0	0
011	37150-27390	BOLT REAMER	4				0.02	0.044
012	02176-50100	NUT	4				0.005	0.011
013	01176-51022	BOLT	44				0.019	0.0418
014	04512-50100	WASHER SPRING	48				0	0
015	35340-27380	STUD	20				0.08	0.176

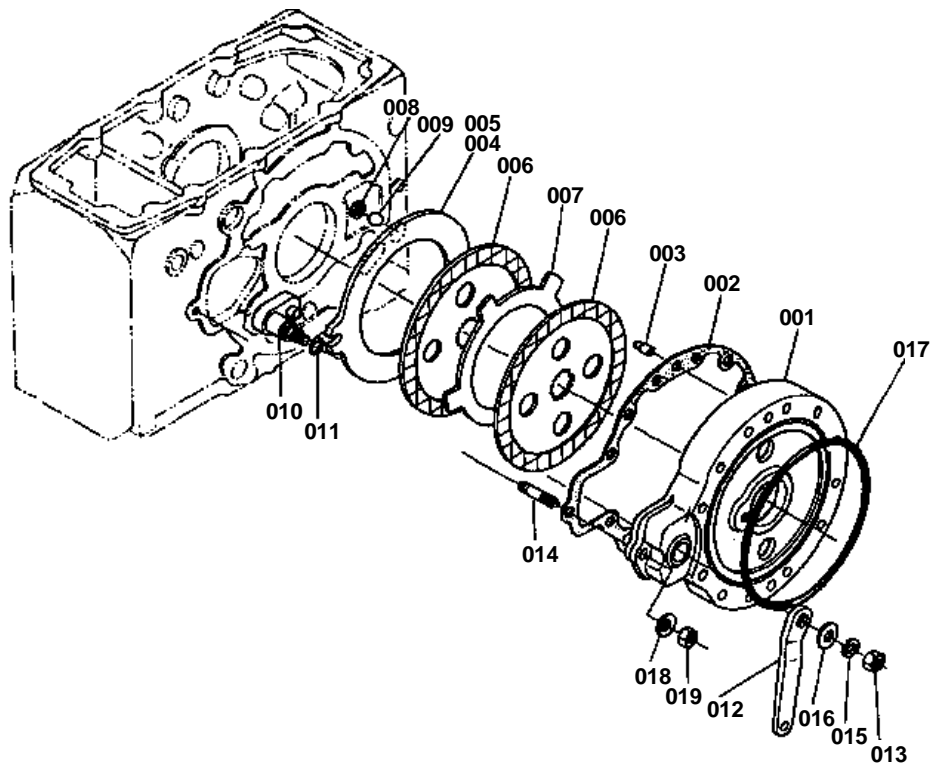

**BRAKE**

↔ Interchangeable; ≠ not interchangeable; ← new for old; → old for new

REF.No	Part No.	Description	Q'ty	S.No.	I/C	REMARKS	Weight (kgf)	Weight (lb)
001	37300-28150	CASE BRAKE	2				6.9	15.18
002	37260-28160	GASKET	2				0	0
003	37300-28170	PIN STRAIGHT	4				0.025	0.055
004	37150-28240	PLATE CAM LH	1				1.13	2.486
005	37150-28270	PLATE CAM RH	1				1.08	2.376
006	37150-28200	DISK BRAKE	4				0	0
007	37720-28170	PLATE	2				0.422	0.9284
008	37150-28250	SEAT BALL	12				0.003	0.0066
009	07715-00805	BALL	12				0.016	0.0352
010	37720-28210	CAM BRAKE	2				0	0
010	37720-28216	CAM BRAKE	2	>=10001			0.34	0.748
011	04811-00180	O RING	2				0.001	0.0022
012	37720-28220	LEVER CAM	2				0.28	0.616
013	02176-50120	NUT	2				0.01	0.022
014	35340-14180	STUD	2				0	0
015	04512-50120	WASHER SPRING	2				0	0
016	04013-50120	WASHER PLAIN	2				0	0
017	37300-27440	O RING	2				0.01	0.022
018	35340-27370	SPRING	2				0.015	0.033
019	37300-27360	NUT	2				0	0
019	35340-27360	NUT	2	>=10001			0.015	0.033



# BRAKE PEDAL

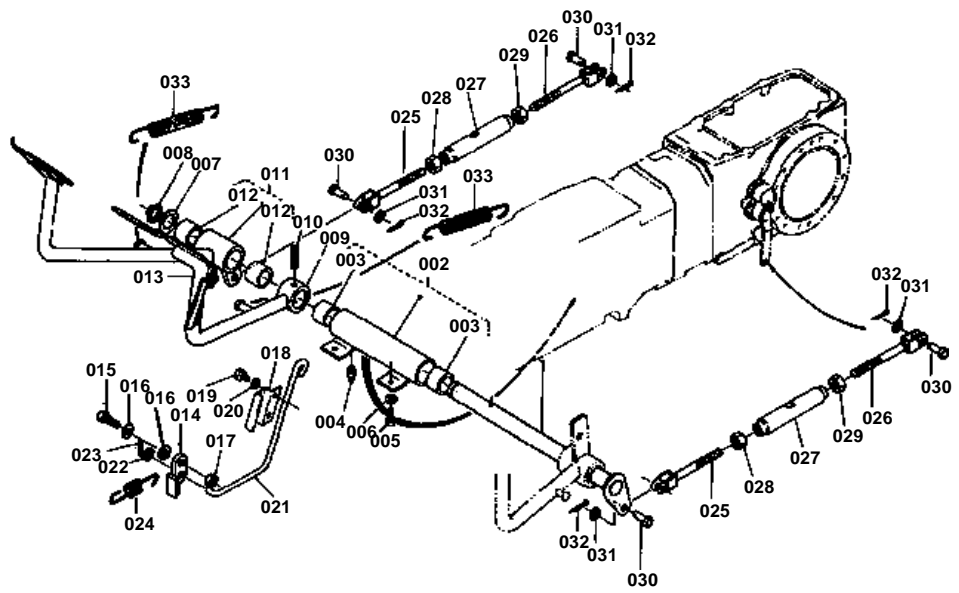

**BRAKE PEDAL**

↔ Interchangeable; ≠ not interchangeable; ← new for old; → old for new

REF.No	Part No.	Description	Q'ty	S.No.	I/C	REMARKS	Weight (kgf)	Weight (lb)
001	37150-28410	SHAFT BRAKE PEDAL	1				1.43	3.146
002	37150-28420	SUPPORT PEDAL SHAFT	1				0.95	2.09
003	34150-28430	BUSH	2				0.04	0.088
004	06613-10675	NIPPLE GREASE	1				0.003	0.0066
005	01173-51020	BOLT	4				0.017	0.0374
006	04512-50100	WASHER SPRING	4				0	0
007	32150-28460	COLLAR	1				0.007	0.0154
008	04612-00250	CIR-CLIP EXTERNAL	1				0.002	0.0044
009	35300-28610	PEDAL BRAKE LH	1				1.5	3.3
010	05411-00840	PIN SPRING	1				0.008	0.0176
011	35300-28620	PEDAL BRAKE RH	1				1.53	3.366
012	34150-28430	BUSH	2				0.04	0.088
013	06613-10675	NIPPLE GREASE	1				0.003	0.0066
014	34150-28810	RATCHET	1				0.045	0.099
015	34150-28820	BOLT	1				0.04	0.088
016	04011-50120	WASHER PLAIN	2				0.005	0.011
017	02174-50120	NUT	1				0.01	0.022
018	34150-28880	GUIDE RATCHET	1				0.04	0.088
019	01150-50812	BOLT	2				0.009	0.0198
020	04512-50080	WASHER SPRING	2				0	0
021	34150-28870	ROD RATCHER	1				0.09	0.198
022	04012-50060	WASHER PLAIN	1				0.001	0.0022
023	05511-50215	PIN SPLIT	1				0.001	0.0022
024	37150-28850	SPRING	1				0.005	0.011
025	35340-28930	ROD BRAKE 1	2				0.19	0.418
026	35340-28940	ROD BRAKE 2	2				0.19	0.418
027	38240-28980	TURNBUCKLE	2				0.29	0.638
028	37300-28990	NUT	2				0.015	0.033
029	02174-50140	NUT	2				0.014	0.0308
030	05122-50828	PIN JOINT	4				0.012	0.0264
031	04012-50080	WASHER PLAIN	4				0.001	0.0022
032	05511-50215	PIN SPLIT	4				0.001	0.0022
033	37150-15840	SPRING	2				0.06	0.132

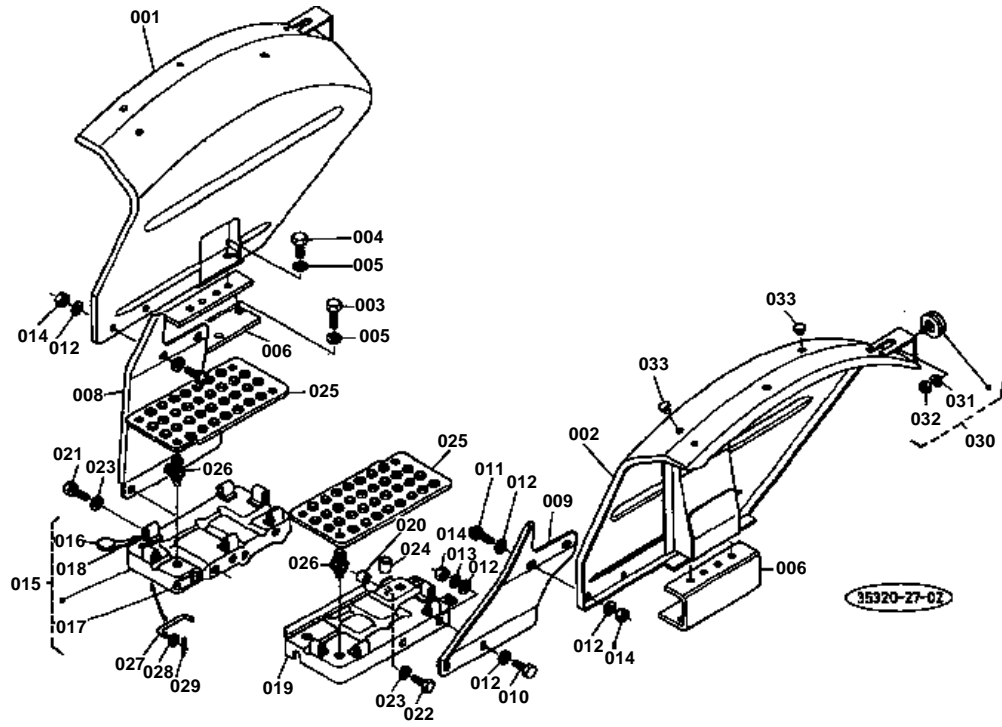

**FENDER**

↔ Interchangeable; ≠ not interchangeable; ← new for old; → old for new

REF.No	Part No.	Description	Q'ty	S.No.	I/C	REMARKS	Weight (kgf)	Weight (lb)
001	37150-29110	FENDER RH	1				6.9	15.18
002	37150-29120	FENDER LH	1				7	15.4
003	01173-51225	BOLT	6				0.033	0.0726
004	01173-51230	BOLT	4				0.037	0.0814
005	04512-50120	WASHER SPRING	10				0	0
006	35320-29210	BRACKET FENDER	2				4.6	10.12
007	99999-99999	BLANK	0				0	0
008	35320-29310	STAY FENDER RH	1				1.49	3.278
009	35320-29320	STAY FENDER LH	1				1.5	3.3
010	01150-50820	BOLT	4				0.011	0.0242
011	03004-50820	BOLT	4				0.011	0.0242
012	04015-50080	WASHER PLAIN	16				0	0
013	04512-50080	WASHER SPRING	4				0	0
014	02114-50080	NUT	8				0.005	0.011
015	37300-29910	ASSY STEP RH	1				2.4	5.28
016	99999-99999	BLANK	0			ORDER BY REF.No.015	0	0
017	99999-99999	BLANK	0			ORDER BY REF.No.015	0	0
018	34150-17530	SPRING	1				0.005	0.011
019	37300-29920	STEP LH	1				2.5	5.5
020	62252-53220	COLLAR	1				0.008	0.0176
021	01170-51016	BOLT	7				0.016	0.0352
022	01170-51035	BOLT	1				0	0
023	04512-50100	WASHER SPRING	8				0	0
024	34150-29130	TUBE VINYL	1				0.001	0.0022
025	37300-29930	SEAT STEP	2				1.15	2.53
026	37300-29940	CUSHION	8				0.013	0.0286
027	37150-17580	ROD ACCELERATOR 2	1				0.025	0.055
028	04012-50060	WASHER PLAIN	2				0.001	0.0022
029	05511-50212	PIN SPLIT	2				0.001	0.0022
030	53143-61240	ASSY REFLECTOR	2				0.009	0.0198
031	04512-50050	WASHER SPRING	2				0	0
032	02013-50050	NUT	2				0.001	0.0022
033	34159-34290	PLUG	4				0.004	0.0088

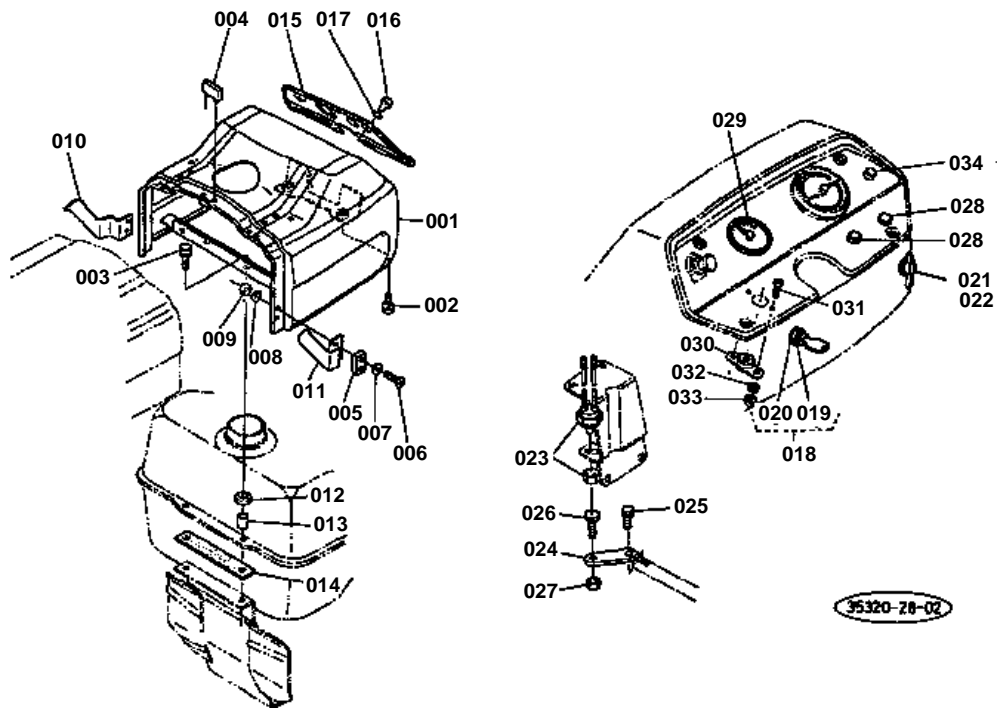

**ELECTRICAL 1**

↔ Interchangeable; ≠ not interchangeable; ← new for old; → old for new

REF.No	Part No.	Description	Q'ty	S.No.	I/C	REMARKS	Weight (kgf)	Weight (lb)
001	37300-31110	PANEL	1				0	0
002	01120-50816	BOLT	2				0	0
003	01120-50830	BOLT	2				0	0
004	33251-83490	CUSHION 1	3				0.008	0.0176
005	37150-18180	CUSHION	2				0.015	0.033
006	03054-50514	SCREW	4				0.004	0.0088
007	04013-50050	WASHER PLAIN	4				0	0
008	04512-50050	WASHER SPRING	4				0	0
009	02054-50050	NUT	4				0.002	0.0044
010	37150-31180	GUIDE RH	1				0.07	0.154
011	37150-31190	GUIDE LH	1				0.065	0.143
012	37300-35120	CUSHION	2				0.003	0.0066
013	37300-35150	SPACER	2				0.005	0.011
014	37300-35160	CUSHION	1				0.025	0.055
015	37300-31120	DASHBOARD	1				0.526	1.1572
016	34150-31140	SCREW	4				0.009	0.0198
017	04013-50080	WASHER PLAIN	4				0	0
018	37150-31820	SWITCH MAIN	1				0.19	0.418
019	37150-31910	NUT RING	1				0.3	0.66
020	37150-31920	PACKING	1				0.001	0.0022
021	37150-32200	SWITCH STARTER	1				0.275	0.605
022	37150-32210	ASSY KNOB	1				0.02	0.044
023	37150-32240	SWITCH SAFETY	1				0.12	0.264
024	37150-34563	PLATE SWITCH	1				0.045	0.099
025	01120-50820	BOLT	1				0	0
026	01952-00830	BOLT	1				0.005	0.011
027	02112-50080	NUT	1				0.003	0.0066
028	35110-32420	PLUG	1				0.002	0.0044
029	34260-31300	THERMOMETER WATER	1				0.144	0.3168
030	15231-65950	LAMP GLOW	1				0.045	0.099
031	03054-50510	SCREW	2				0.003	0.0066
032	04512-50050	WASHER SPRING	2				0	0
033	02054-50050	NUT	2				0.002	0.0044
034	34159-32610	CAP	1				0	0

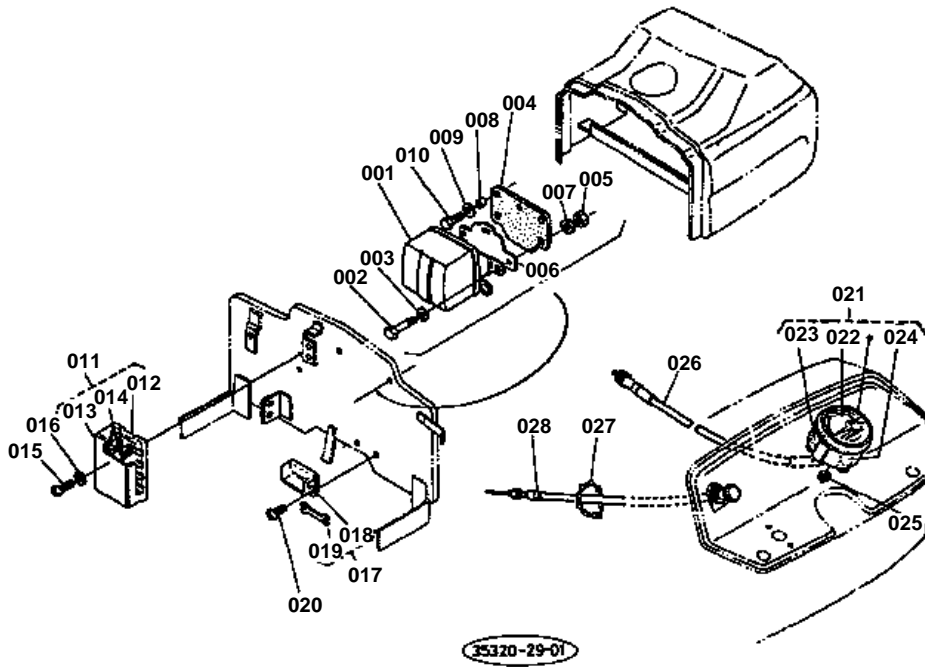

REF. No. 35320-3370-0  
01202-50616



**ELECTRICAL 2**

↔ Interchangeable; ≠ not interchangeable; ← new for old; → old for new

REF.No	Part No.	Description	Q'ty	S.No.	I/C	REMARKS	Weight (kgf)	Weight (lb)
001	33251-74010	ASSY REGULATOR	1				0.35	0.77
002	37300-33460	BOLT	3				0.005	0.011
003	04012-50060	WASHER PLAIN	3				0.001	0.0022
004	37300-33430	CUSHION	1				0.1	0.22
005	02014-50060	NUT	3				0.003	0.0066
006	37300-33420	COVER REGULATOR	1				0.07	0.154
007	37300-33440	CUSHION	3				0.001	0.0022
008	37300-33450	COLLAR	2				0.005	0.011
009	04015-50060	WASHER PLAIN	2				0	0
010	01202-50622	BOLT	2				0.007	0.0154
011	34260-33600	ASSY CASE FUSE	1				0.042	0.0924
012	34260-33610	BOX FUSE	1				0.042	0.0924
013	34260-33620	COVER FUSE BOX	1				0.01	0.022
014	34260-33630	FUSE	6				0.001	0.0022
015	03054-50520	SCREW	2				0.005	0.011
016	04512-50050	WASHER SPRING	4				0	0
017	34260-33650	ASSY FUSE	1				0.035	0.077
018	54213-25150	CASE FUSE	1				0	0
019	34260-33660	FUSE	1				0.002	0.0044
020	03054-50514	SCREW	2				0.004	0.0088
021	35340-34600	METER TRACTOR	1				0.41	0.902
022	99999-99999	BLANK	0			ORDER BY REF.No.021	0	0
023	32150-31740	VALVE LAMP	1				0.003	0.0066
024	34150-34620	VALVE LAMP	1				0.001	0.0022
025	02054-50050	NUT	1				0.002	0.0044
026	35340-34650	CABLE TRACTOR METER	1				0.25	0.55
027	34350-29380	BAND CORD	1				0.001	0.0022
028	35320-34700	WIRE DECOMPRESS	1				0.11	0.242
029	35320-33700	UNIT FLASHER	1	≤10316		U.S.A.	0.07	0.154
030	01202-50616	BOLT	1	≤10316		U.S.A.	0.006	0.0132



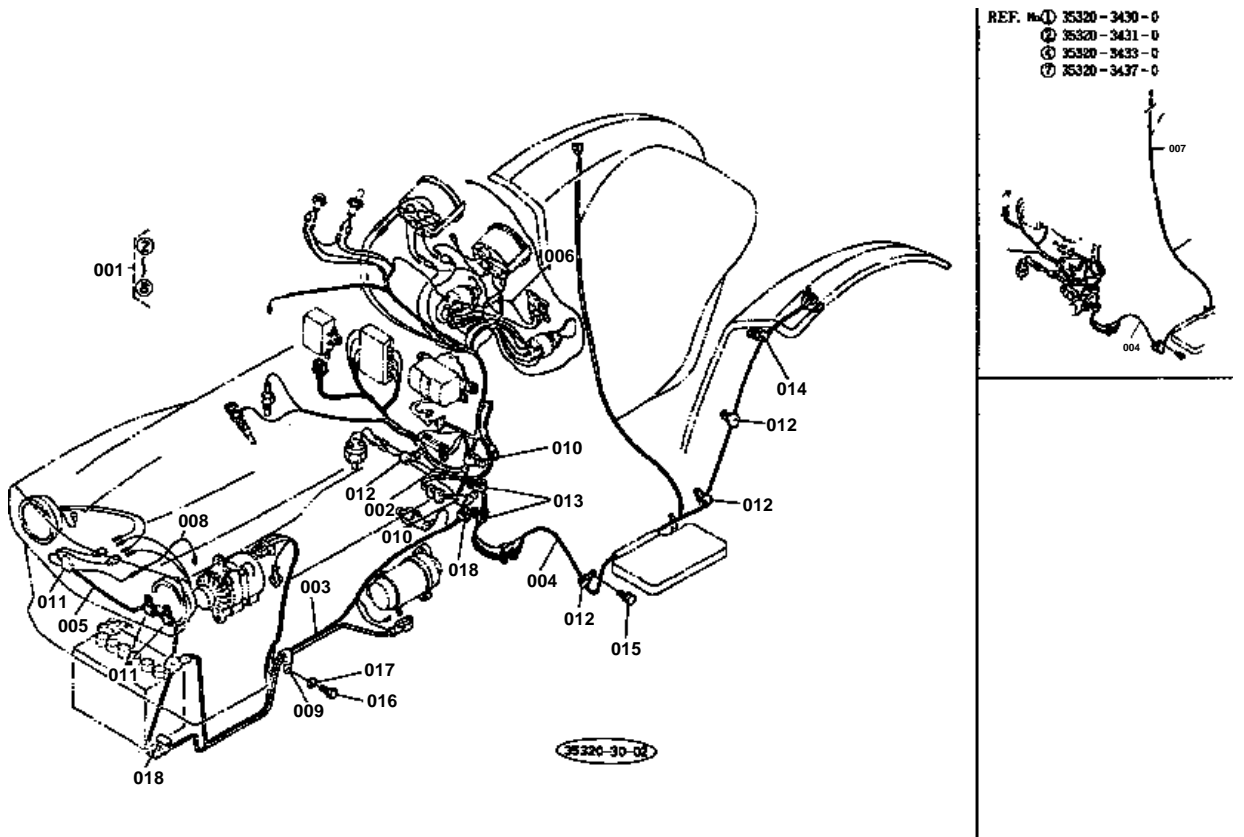

**ELECTRICAL 3**

↔ Interchangeable; ≠ not interchangeable; ← new for old; → old for new

REF.No	Part No.	Description	Q'ty	S.No.	I/C	REMARKS	Weight (kgf)	Weight (lb)
001	35320-34300	ASSY WIRE HARNESS	1	≤10316			1.1	2.42
001	35320-34303	ASSY WIRE HARNESS	1	≥10317			1.22	2.684
002	35320-34310	WIRE HARNESS 1	1	≤10316			0.7	1.54
002	35320-34312	WIRE HARNESS 1	1	≥10317			0.7	1.54
003	35300-34320	WIRE HARNESS 2	1				0.265	0.583
004	35320-34330	WIRE HARNESS 3	1	≤10316			0.155	0.341
004	35346-34330	WIRE HARNESS 3	1	≥10317			0.2	0.44
005	35300-34340	WIRE HARNESS 4	1				0.05	0.11
006	37300-34350	WIRE HARNESS 5	1				0.016	0.0352
007	35320-34370	WIRE HARNESS 7	2	≤10316			0.01	0.022
008	35110-34350	CORD HEAD LAMP EARTH	1				0.005	0.011
009	35340-29380	CLAMP CORD	1				0.01	0.022
010	34150-29390	CLAMP CORD	2				0.004	0.0088
011	34150-34480	CLAMP CORD	3				0.002	0.0044
012	32240-34490	CLAMP CORD 2	6				0.003	0.0066
013	37150-34460	CLAMP CORD	2				0.03	0.066
014	32240-34460	CLAMP CORD	2				0.011	0.0242
015	01120-50814	BOLT	1				0	0
016	01173-51218	BOLT	1				0.028	0.0616
017	04512-50120	WASHER SPRING	1				0	0
018	70415-52150	CUSHION	2				0	0

# FUEL TANK

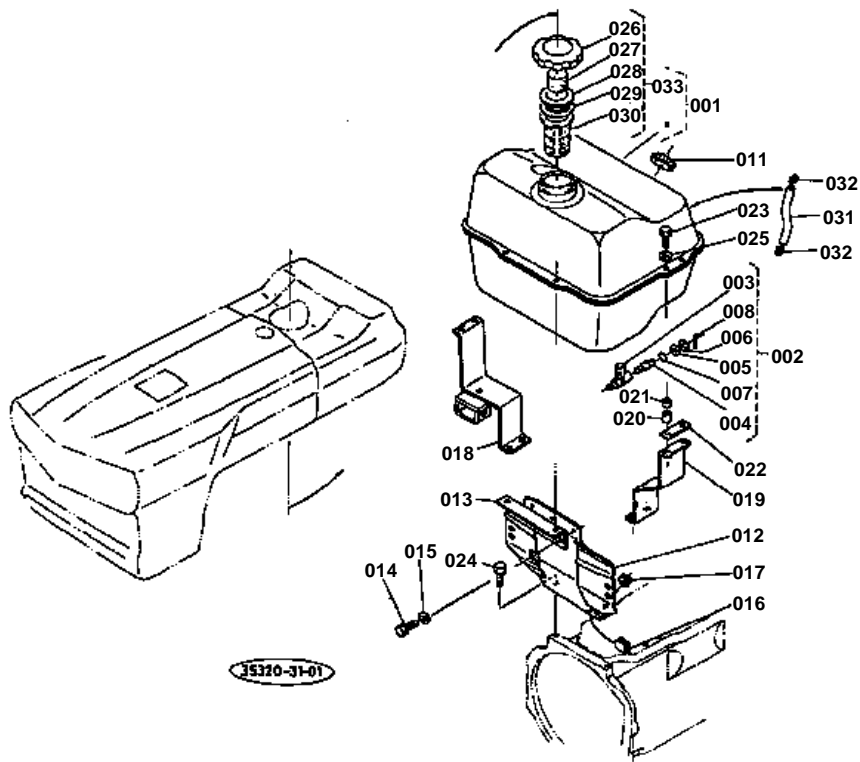

REF. No. 35320-3528-0

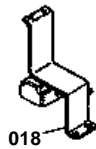

018

REF. No. 04717-01000  
06311-25010



010

009

OUTLET DRAIN

Discontinua.

**FUEL TANK**

↔ Interchangeable; ≠ not interchangeable; ← new for old; → old for new

REF.No	Part No.	Description	Q'ty	S.No.	I/C	REMARKS	Weight (kgf)	Weight (lb)
001	35350-35100	ASSY TANK FUEL	1				6.7	14.74
002	31220-35400	ASSY COCK FUEL	1				0.11	0.242
003	99999-99999	BLANK	0			ORDER BY REF.No.002	0	0
004	99999-99999	BLANK	0			ORDER BY REF.No.002	0	0
005	32130-35430	WASHER	1				0.001	0.0022
006	04611-00140	CIR-CLIP INTERNAL	1				0.001	0.0022
007	04811-00080	O RING	1				0.001	0.0022
008	05411-00330	PIN SPRING	1				0.001	0.0022
009	06311-55010	PLUG	1	<=10342			0.015	0.033
010	04717-01000	WASHER SEAL	1	<=10342			0.001	0.0022
011	37300-35550	BUSH FUEL	1				0.014	0.0308
012	37300-35270	SUPPORT FUEL TANK	1				2.3	5.06
013	37300-35260	BRACKET	1				0.196	0.4312
014	01130-51020	BOLT	3				0	0
015	04015-50100	WASHER PLAIN	3				0.016	0.0352
016	37150-13920	CUSHION	1				0.005	0.011
017	32150-29180	CAP RUBBER	1				0.002	0.0044
018	35330-35280	STAY FUEL TANK RH	1	<=10316			1.44	3.168
018	35350-35282	STAY FUEL TANK RH	1	>=10317			0	0
019	35350-35290	STAY FUEL TANK LH	1				0.905	1.991
020	37300-35140	SPACER	4				0.006	0.0132
021	37300-35130	CUSHION	2				0.007	0.0154
022	37300-35120	CUSHION	4				0.003	0.0066
023	01120-50830	BOLT	4				0	0
024	01120-50818	BOLT	2				0	0
025	04015-50080	WASHER PLAIN	6				0	0
026	99999-99999	BLANK	0			ORDER BY REF.No.033	0	0
027	34150-35240	SPONGE	1				0.001	0.0022
028	34150-35230	GASKET	1				0.01	0.022
029	34150-35180	GASKET	1				0.001	0.0022
030	13251-41060	FILTER	1				0.01	0.022
031	07935-05741	GAUGE	1				0.16	0.352
032	10013-41770	CLIP PIPE	2				0.005	0.011
033	38240-35200	ASSY CAP	1				0.06	0.132

# FUEL FILTER

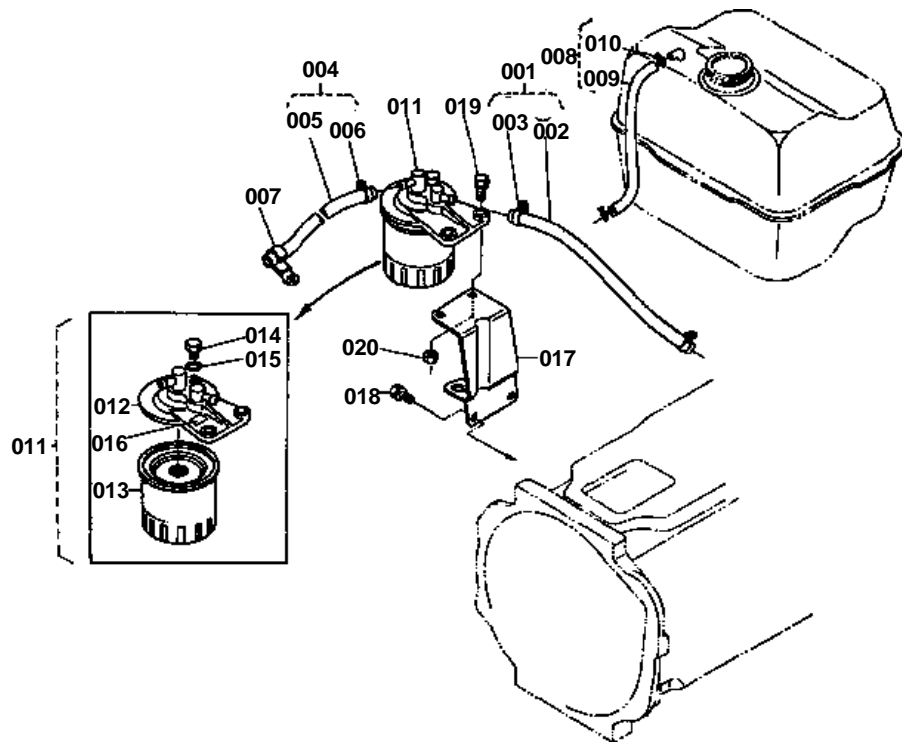

**FUEL FILTER**

↔ Interchangeable; ≠ not interchangeable; ← new for old; → old for new

REF.No	Part No.	Description	Q'ty	S.No.	I/C	REMARKS	Weight (kgf)	Weight (lb)
001	37300-35500	ASSY PIPE FUEL 1	1				0.055	0.121
002	99999-99999	BLANK	0			ORDER BY REF.No.001	0	0
003	14301-42750	CLIP PIPE	2				0.005	0.011
004	35320-35520	ASSY PIPE FUEL 2	1				0.075	0.165
005	99999-99999	BLANK	0			ORDER BY REF.No.004	0	0
006	14301-42750	CLIP PIPE	2				0.005	0.011
007	34150-29390	CLAMP CORD	1				0.004	0.0088
008	35340-35550	ASSY PIPE FUEL 3	1				0.027	0.0594
009	99999-99999	BLANK	0			ORDER BY REF.No.008	0	0
010	10244-42320	CLIP PIPE	2				0.001	0.0022
011	15291-43010	ASSY FILTER FUEL	1				0.555	1.221
012	15291-43210	COVER FILTER	1				0.23	0.506
013	15221-43080	ELEMENT FILTER	1				0	0
014	14102-43280	PLUG FILTER BREATHER	1				0	0
015	15108-43290	O RING	1				0.001	0.0022
016	15291-87760	MARK FORM	1				0.005	0.011
017	37300-35810	BRACKET FILTER	1				0.4	0.88
018	01120-50816	BOLT	2				0	0
019	01120-50822	BOLT	2				0	0
020	02156-50080	NUT	2				0.004	0.0088

# OIL PRESSURE 1

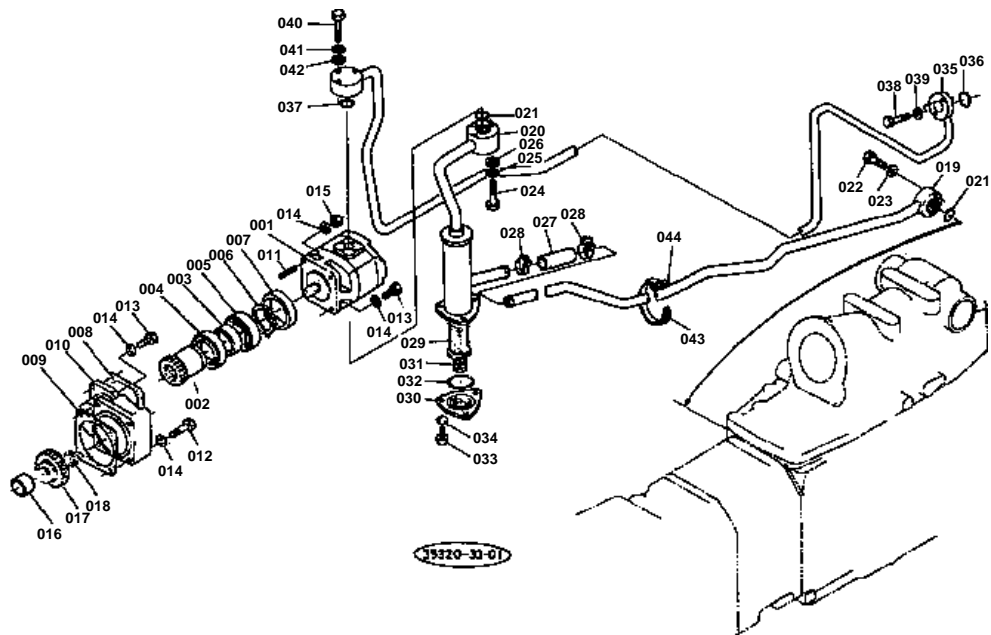



# OIL PRESSURE 1

↔ Interchangeable; ≠ not interchangeable; ← new for old; → old for new

REF.No	Part No.	Description	Q'ty	S.No.	I/C	REMARKS	Weight (kgf)	Weight (lb)
001	35320-36100	PUMP OIL PRESSURE	1				0	0
002	37810-37830	GEAR SPUR 23	1				0.238	0.5236
003	37300-37770	LACE INNER	1				0.07	0.154
004	37300-37780	BEARING NEEDLE	1				0.11	0.242
005	08101-06907	BEARING BALL	1				0.073	0.1606
006	04612-00350	CIR-CLIP EXTERNAL	1				0.01	0.022
007	37300-37790	COLLAR	1				0.025	0.055
008	34150-37870	GASKET	1				0	0
009	34150-37860	GASKET	1				0	0
010	37300-37850	HOLDER O/P PUMP	1				1.365	3.003
011	01513-50820	STUD	2				0	0
012	01153-50845	BOLT	2				0.018	0.0396
013	01153-50822	BOLT	4				0.011	0.0242
014	04512-50080	WASHER SPRING	8				0	0
015	02156-50080	NUT	2				0.004	0.0088
016	34150-37820	COLLAR	1				0.05	0.11
017	37300-37810	GEAR SPUR 44	1				0.325	0.715
018	04612-00250	CIR-CLIP EXTERNAL	1				0.002	0.0044
019	35340-38110	PIPE INLET	1				1.55	3.41
020	35320-38120	ASSY CASE FILTER	1				0.97	2.134
021	04811-00200	O RING	2				0.001	0.0022
022	01153-50850	BOLT	2				0.02	0.044
023	04512-50080	WASHER SPRING	2				0	0
024	01053-50642	BOLT	3				0.011	0.0242
025	04512-50060	WASHER SPRING	3				0	0
026	04013-50060	WASHER PLAIN	3				0	0
027	34350-37770	PIPE RUBBER	1				0	0
028	34350-37780	CLAMP	2				0.02	0.044
029	37300-37710	FILTER OIL	1				0.145	0.319
030	34350-37742	COVER FILTER	1				0.319	0.7018
031	37300-37740	SPRING	1				0.005	0.011
032	04811-50600	O RING	1				0.002	0.0044
033	01153-50820	BOLT	3				0.012	0.0264
034	04512-50080	WASHER SPRING	3				0	0
035	35320-38210	ASSY PIPE DELIVERY	1				1	2.2
036	04810-00120	O RING	1				0.001	0.0022
037	04810-00200	O RING	1				0.001	0.0022
038	01153-50830	BOLT	2				0	0
039	04512-50080	WASHER SPRING	2				0	0
040	01053-50630	BOLT	3				0.009	0.0198
041	04512-50060	WASHER SPRING	3				0	0
042	04013-50060	WASHER PLAIN	3				0	0
043	33251-82760	BAND PIPE	2				0.016	0.0352
044	33430-82760	PIN PIPE BAND	2				0.004	0.0088



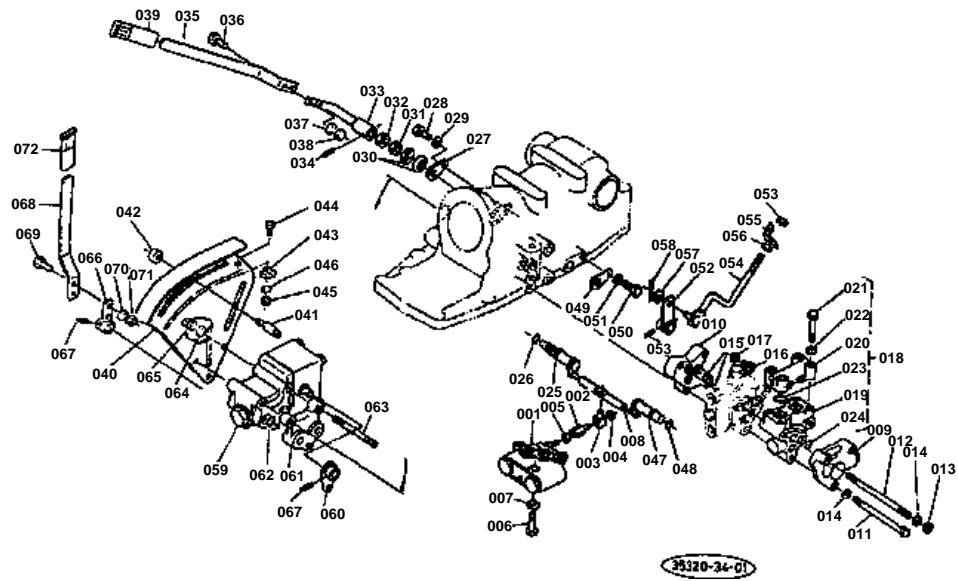



## OIL PRESSURE 2

↔ Interchangeable; ≠ not interchangeable; ← new for old; → old for new

REF.No	Part No.	Description	Q'ty	S.No.	I/C	REMARKS	Weight (kgf)	Weight (lb)
001	37150-36400	VALVE CONTROL	1				1.675	3.685
002	37150-36410	JOINT SPOOL 1	1				0.001	0.0022
003	37150-36420	JOINT SPOOL 2	1				0.02	0.044
004	04613-00060	CIR-CLIP EXTERNAL	1				0	0
005	02112-50080	NUT	1				0.003	0.0066
006	01153-50850	BOLT	3				0.02	0.044
007	04512-50080	WASHER SPRING	3				0	0
008	37150-36430	LEVER SPOOL DRIVE	1				0.09	0.198
009	35320-36600	VALVE RELIEF	1				0.89	1.958
010	37150-36610	SPACER	1				0.14	0.308
011	35270-36810	BOLT	2				0.059	0.1298
012	35270-36820	STUD	1				0.65	1.43
013	02156-50080	NUT	1				0.004	0.0088
014	04512-50080	WASHER SPRING	3				0	0
015	04810-00140	O RING	6				0.001	0.0022
016	06331-35010	PLUG	1				0.012	0.0264
017	04717-01000	WASHER SEAL	1				0.001	0.0022
018	35300-36700	ASSY BLOCK OIL PRESS	1				2	4.4
019	35300-36710	BLOCK OIL PRESSURE	1				1.6	3.52
020	35300-36720	COVER OIL PRESSURE B	1				0.385	0.847
021	01153-50840	BOLT	4				0.018	0.0396
022	04512-50080	WASHER SPRING	4				0	0
023	04810-00200	O RING	2				0.001	0.0022
024	04810-00120	O RING	3				0.001	0.0022
025	37150-37650	ARM CONTROL	1				0.11	0.242
026	04811-00110	O RING	1				0.001	0.0022
027	34260-36890	PLATE SET	1				0.009	0.0198
028	01153-50816	BOLT	1				0.01	0.022
029	04512-50080	WASHER SPRING	1				0	0
030	34260-36880	SPRING	2				0.006	0.0132
031	02172-50140	NUT	1				0.01	0.022
032	02174-50140	NUT	1				0.014	0.0308
033	37300-36840	LEVER CONTROL 1	1				0.195	0.429
034	05411-00525	PIN SPRING	2				0.002	0.0044
035	35212-36850	LEVER CONTROL 2	1				0.178	0.3916
036	01053-50616	BOLT	2				0.005	0.011
037	04512-50060	WASHER SPRING	2				0	0
038	02056-50060	NUT	2				0.002	0.0044
039	34350-36890	GRIP LEVER	1				0.016	0.0352
040	37300-36860	GUIDE LEVER	1				0.985	2.167
041	37300-36910	STOPPER	1				0.05	0.11
042	37300-36920	NUT	1				0.046	0.1012
043	37300-36930	STOPPER	1				0.02	0.044
044	01170-51018	BOLT	1				0.017	0.0374
045	02118-50100	NUT	1				0.005	0.011
046	04512-50100	WASHER SPRING	1				0	0
047	37150-37670	SHAFT LEVER	1				0.085	0.187
048	04811-00110	O RING	1				0.001	0.0022
049	34260-36890	PLATE SET	1				0.009	0.0198
050	01153-50816	BOLT	1				0.01	0.022
051	04512-50080	WASHER SPRING	1				0	0
052	37150-37680	LEVER FEEDBACK	1				0.05	0.11
053	05411-00420	PIN SPRING	1				0.001	0.0022
054	37220-37690	ROD FEEDBACK	1				0.055	0.121
055	37220-37640	PLATE CONTROL	1				0.025	0.055
056	02114-50080	NUT	2				0.005	0.011
057	04013-50080	WASHER PLAIN	2				0	0
058	05511-50215	PIN SPLIT	2				0.001	0.0022
059	37300-41100	ASSY VALVE DRAFT CON	1				3.2	7.04



## OIL PRESSURE 2

↔ Interchangeable; ≠ not interchangeable; ← new for old; → old for new

REF.No	Part No.	Description	Q'ty	S.No.	I/C	REMARKS	Weight (kgf)	Weight (lb)
060	37300-41190	LEVER FEEDBACK	1				0.056	0.1232
061	37300-41210	SPACER	1				0	0
062	04810-00160	O RING	2				0.001	0.0022
063	37300-41250	STUD	3				0.04	0.088
064	04512-50080	WASHER SPRING	3				0	0
065	02156-50080	NUT	3				0.004	0.0088
066	37300-41220	LEVER DRAFT CONTROL	1				0.042	0.0924
067	05411-00525	PIN SPRING	2				0.002	0.0044
068	35212-41230	LEVER DRAFT CONTROL	1				0.14	0.308
069	01053-50616	BOLT	2				0.005	0.011
070	04512-50060	WASHER SPRING	2				0	0
071	02056-50060	NUT	2				0.002	0.0044
072	34350-36890	GRIP LEVER	1				0.016	0.0352

O/P CYLINDER

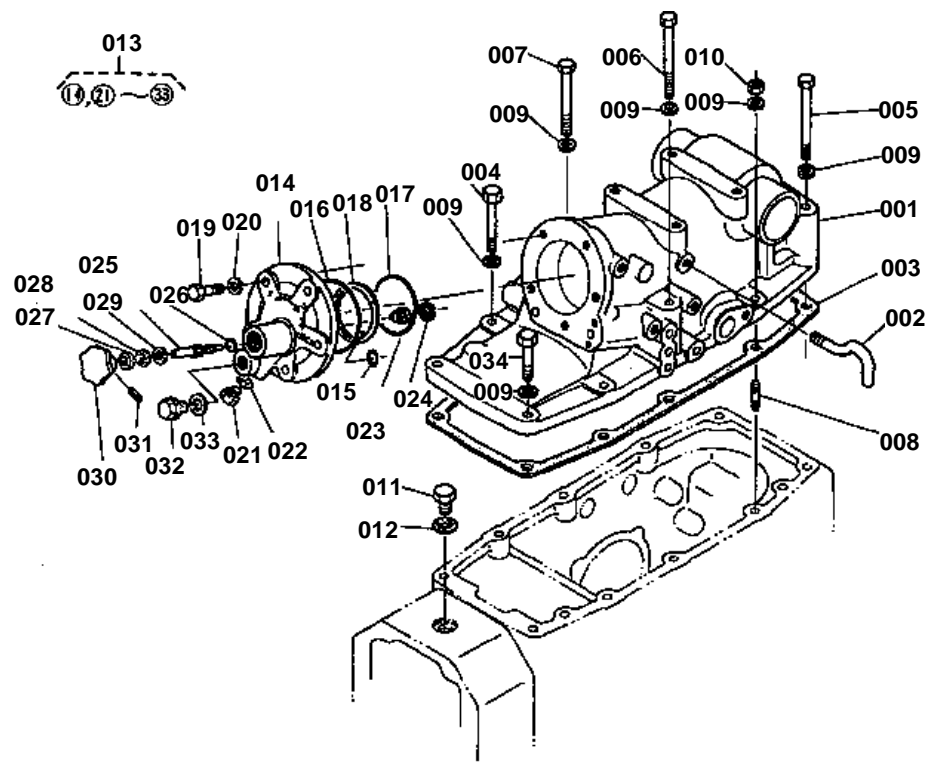

**O/P CYLINDER**

↔ Interchangeable; ≠ not interchangeable; ← new for old; → old for new

REF.No	Part No.	Description	Q'ty	S.No.	I/C	REMARKS	Weight (kgf)	Weight (lb)
001	35340-37110	CYLINDER O/P	1				22.9	50.38
002	34260-37270	PIPE BREATHER	1				0.03	0.066
003	37150-37120	GASKET	1				0	0
004	01173-51240	BOLT	2				0.045	0.099
005	34260-37180	BOLT	2				0.115	0.253
006	01173-51295	BOLT	1				0.086	0.1892
007	01173-51201	BOLT	1				0.094	0.2068
008	01574-51240	STUD	2				0	0
009	04512-50120	WASHER SPRING	10				0	0
010	02176-50120	NUT	2				0.01	0.022
011	06311-45030	PLUG	1				0.06	0.132
012	04717-01700	WASHER SEAL	1				0.003	0.0066
013	37300-37200	ASSY COVER O/P CYL.	1				3.7	8.14
014	99999-99999	BLANK	0			ORDER BY REF.No.013	0	0
015	04810-00140	O RING	1				0.001	0.0022
016	04811-51000	O RING	1				0.003	0.0066
017	04810-50800	O RING	1				0.002	0.0044
018	37300-37260	RING BACK UP	1				0.002	0.0044
019	01173-51240	BOLT	5				0.045	0.099
020	04512-50120	WASHER SPRING	5				0	0
021	37150-36740	PLUG	1				0.025	0.055
022	04724-00100	GASKET	1				0.001	0.0022
023	34150-37250	COLLAR ADJUSTING	1				0.01	0.022
024	04611-00180	CIR-CLIP INTERNAL	1				0.001	0.0022
025	34150-37220	SCREW ADJUSTING	1				0.025	0.055
026	04810-00100	O RING	1				0.001	0.0022
027	09230-08164	SEAL OIL	1				0.001	0.0022
028	34150-37260	CIR-CLIP INTERNAL	1				0.001	0.0022
029	04012-50080	WASHER PLAIN	1				0.001	0.0022
030	34150-37230	GRIP	1				0.04	0.088
031	05411-00418	PIN SPRING	1				0.001	0.0022
032	37150-36730	PLUG	1				0.03	0.066
033	37150-36720	GASKET	1				0.01	0.022
034	01173-51255	BOLT	2				0.057	0.1254

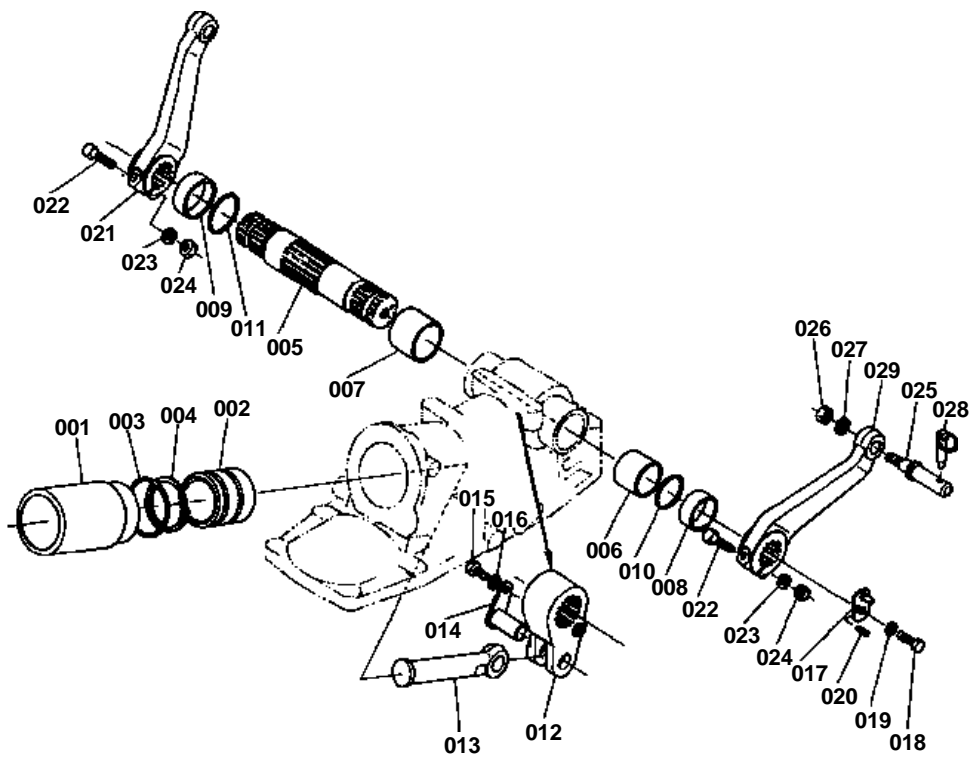

**O/P LIFT ARM SYSTEM**

↔ Interchangeable; ≠ not interchangeable; ← new for old; → old for new

REF.No	Part No.	Description	Q'ty	S.No.	I/C	REMARKS	Weight (kgf)	Weight (lb)
001	37300-37130	LINER CYLINDER	1				2.54	5.588
002	37300-37310	PISTON OIL PRESSURE	1				1.76	3.872
003	04810-00750	O RING	2				0.003	0.0066
004	34350-37330	RING BACK UP	1				0.004	0.0088
005	34260-37430	SHAFT O/P ARM	1				3.2	7.04
006	32240-37450	BUSH	1				0	0
007	32240-37460	BUSH	1				0	0
008	37300-37480	COLLAR	1				0.01	0.022
009	37300-37490	COLLAR	1				0.01	0.022
010	04811-50450	O RING	1				0.002	0.0044
011	04811-50500	O RING	1				0.001	0.0022
012	37220-37440	ARM OIL PRESSURE	1				1.71	3.762
013	37300-37320	ROD OIL PRESSURE	1				0.5	1.1
014	32240-37340	PIN SET	1				0.2	0.44
015	01173-51018	BOLT	1				0.018	0.0396
016	04512-50100	WASHER SPRING	1				0	0
017	37300-37660	LINK CONTROL	1				0.04	0.088
018	01170-51222	BOLT	1				0	0
019	04512-50120	WASHER SPRING	1				0	0
020	05411-00414	PIN SPRING	1				0.001	0.0022
021	35300-37610	ARM LIFT RH	1				2.76	6.072
022	01173-51280	BOLT	2				0.1	0.22
023	04512-50120	WASHER SPRING	2				0	0
024	02176-50120	NUT	2				0.01	0.022
025	37300-37690	PIN LIFT ROD	2				0	0
025	32240-37695	PIN LIFT ROD	2	>=10001			0.2	0.44
026	02176-50160	NUT	2				0.021	0.0462
027	04512-50160	WASHER SPRING	2				0	0
028	34150-37640	PIN SET	2				0.06	0.132
029	35300-37620	ARM LIFT LH	1				2.72	5.984

# TOP LINK BRACKET

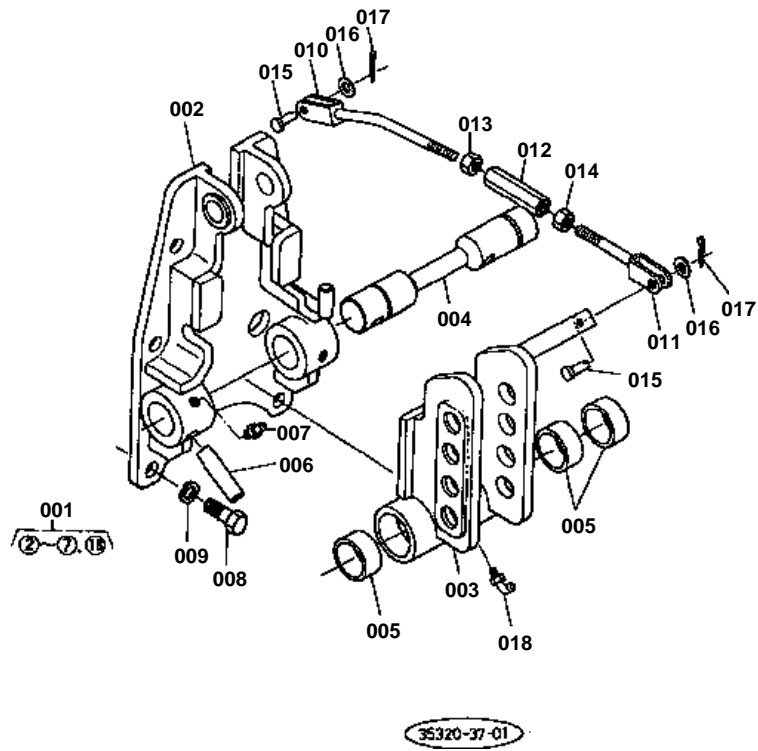





# TOP LINK BRACKET

↔ Interchangeable; ≠ not interchangeable; ← new for old; → old for new

REF.No	Part No.	Description	Q'ty	S.No.	I/C	REMARKS	Weight (kgf)	Weight (lb)
001	35300-41400	ASSY BRACKET TOP LIN	1				0	0
002	99999-99999	BLANK	0			ORDER BY REF.No.001	0	0
003	99999-99999	BLANK	0			ORDER BY REF.No.001	0	0
004	99999-99999	BLANK	0			ORDER BY REF.No.001	0	0
005	37300-41450	BUSH	3				0.03	0.066
006	37300-41440	PIN STRAIGHT	2				0.055	0.121
007	06613-10010	NIPPLE GREASE	1				0.006	0.0132
008	01173-51228	BOLT	6				0.036	0.0792
009	04512-50120	WASHER SPRING	6				0	0
010	37300-41310	ROD DRAFT CONTROL	1				0.07	0.154
011	37300-41320	ROD DRAFT CONTROL	1				0.04	0.088
012	66591-42410	TURNBUCKLE	1				0.046	0.1012
013	02114-50080	NUT	1				0.005	0.011
014	37300-41330	NUT	1				0.005	0.011
015	05122-50818	PIN JOINT	2				0.008	0.0176
016	04012-50080	WASHER PLAIN	2				0.001	0.0022
017	05511-50218	PIN SPLIT	2				0.001	0.0022
018	06613-20010	NIPPLE GREASE	2				0.01	0.022

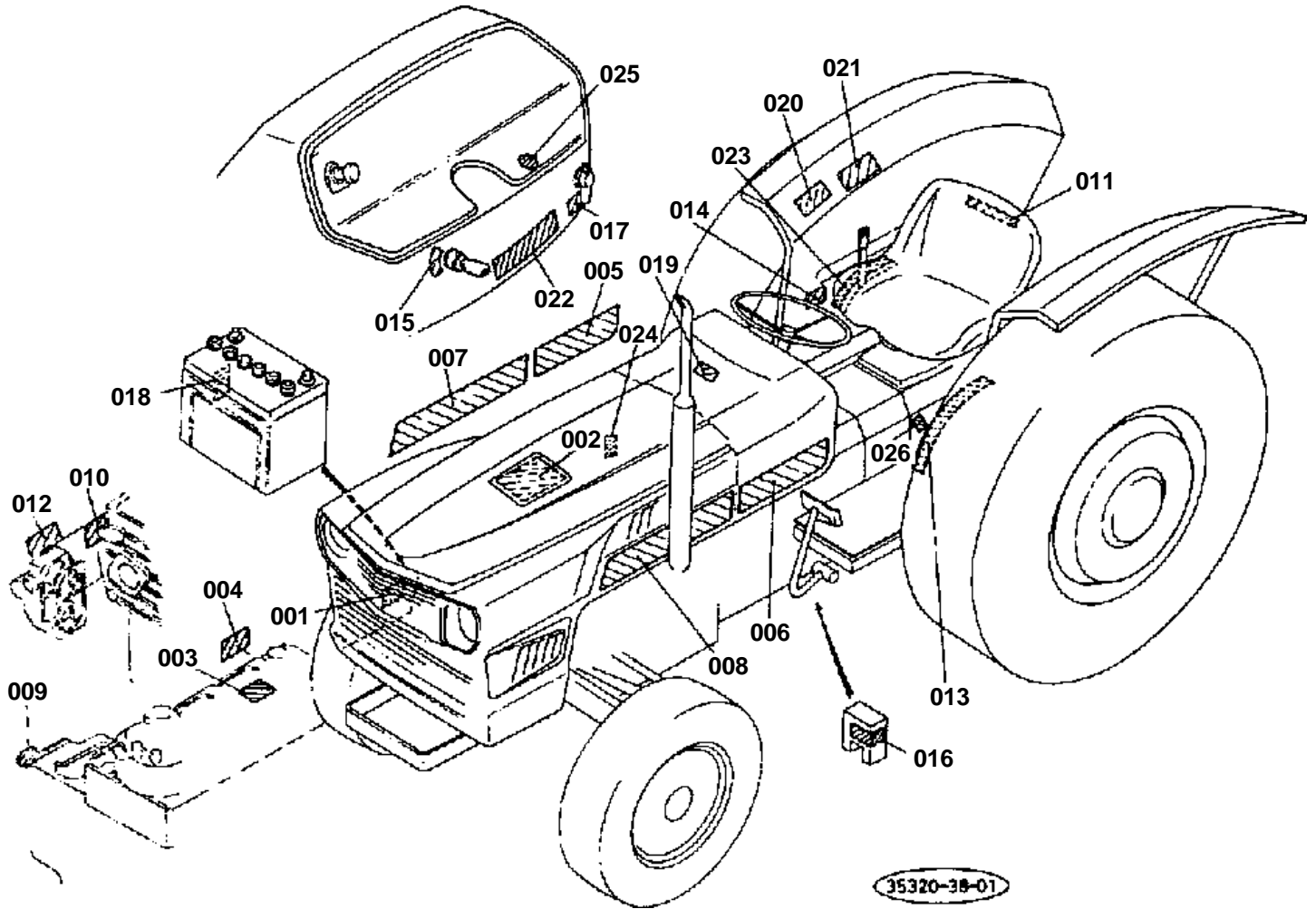



## LABEL

↔ Interchangeable; ≠ not interchangeable; ← new for old; → old for new

REF.No	Part No.	Description	Q'ty	S.No.	I/C	REMARKS	Weight (kgf)	Weight (lb)
001	35176-18360	LABEL DRAIN	1				0.001	0.0022
002	15101-94610	LABEL	1				0.002	0.0044
003	15303-88310	LABEL	1				0.001	0.0022
004	15222-88210	LABEL	1				0.003	0.0066
005	37300-18760	MARK SIDE KUBOTA RH	1				0.01	0.022
006	37300-18770	MARK SIDE KUBOTA LH	1				0.02	0.044
007	35320-18780	MARK RH	1				0.017	0.0374
008	35320-18790	MARK LH	1				0.02	0.044
009	15222-87210	LABEL	1				0.001	0.0022
010	15103-94590	LABEL	1				0.001	0.0022
011	32140-18470	MARK KUBOTA	1				0.002	0.0044
012	15213-94400	LABEL	1				0.001	0.0022
013	35340-24580	MARK AUX-CHANGE	1				0.001	0.0022
014	35176-26690	LABEL	1				0.001	0.0022
015	35176-31830	LABEL	1				0.001	0.0022
016	35176-15930	LABEL	1				0.005	0.011
017	35320-32290	LABEL	1				0.001	0.0022
017	35170-32290	LABEL	1			≤=10316 ≥=10317	0.001	0.0022
018	35340-33130	LABEL	1				0.002	0.0044
019	35176-35250	LABEL	1				0.025	0.055
020	35176-34930	LABEL	1				0.001	0.0022
021	35176-34910	LABEL	1				0.01	0.022
022	35340-34920	LABEL	1				0.025	0.055
023	35212-36980	LABEL	1				0.005	0.011
024	35176-37750	LABEL	1				0.02	0.044
025	35320-31840	LABEL HAZARD	1				0.005	0.011

# FLOW PRIORITY VALVE

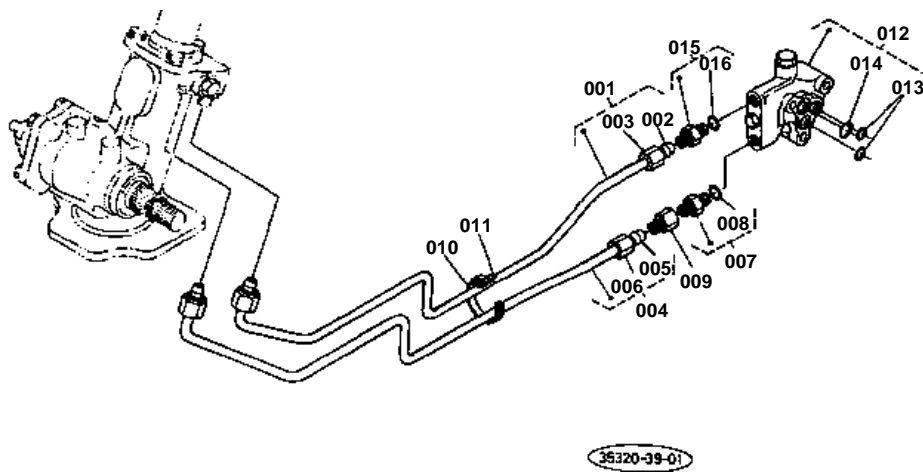



# FLOW PRIORITY VALVE

↔ Interchangeable; ≠ not interchangeable; ← new for old; → old for new

REF.No	Part No.	Description	Q'ty	S.No.	I/C	REMARKS	Weight (kgf)	Weight (lb)
001	35330-16720	ASSY PIPE 1	1				0.25	0.55
002	99999-99999	BLANK	0			ORDER BY REF.No.001	0	0
003	99999-99999	BLANK	0			ORDER BY REF.No.001	0	0
004	35330-16760	ASSY PIPE 2	1				0.26	0.572
005	99999-99999	BLANK	0			ORDER BY REF.No.002	0	0
006	99999-99999	BLANK	0			ORDER BY REF.No.002	0	0
007	35330-16770	ASSY CONNECTOR	1				0.065	0.143
008	04810-00140	O RING	1				0.001	0.0022
009	35330-16790	NIPPLE	1				0.05	0.11
010	37150-38950	BAND PIPE	1				0.02	0.044
010	67111-53771	BAND PIPE	1	>=10001			0	0
011	33430-82760	PIN	1				0.004	0.0088
012	35320-16710	VALVE FLOW PRIORITY	1				1.9	4.18
013	04810-00120	O RING	2				0.001	0.0022
014	04810-00160	O RING	1				0.001	0.0022
015	35270-16790	JOINT 2	1				0.05	0.11
016	04810-00140	O RING	1				0.001	0.0022

# 3-POINT LINKAGE

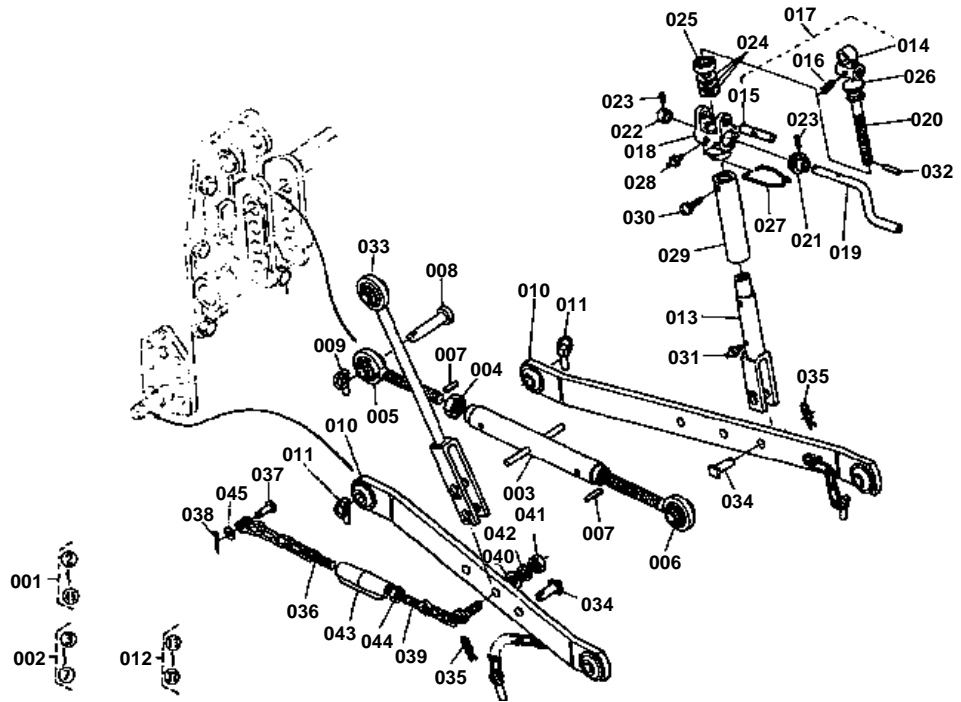



### 3-POINT LINKAGE

↔ Interchangeable; ≠ not interchangeable; ← new for old; → old for new

REF.No	Part No.	Description	Q'ty	S.No.	I/C	REMARKS	Weight (kgf)	Weight (lb)
001	99999-99999	BLANK	0			ORDER BY REF.No.002 TO 045	0	0
002	37307-71100	ASSY LINK TOP	1				0	0
003	32244-71110	LINK TOP	1				1.01	2.222
004	32244-71180	NUT TOP LINK	1				0.057	0.1254
005	37307-71210	JOINT TOP LINK 1	1				1.05	2.31
006	37307-71220	JOINT TOP LINK 2	1				1.065	2.343
007	05411-00425	PIN SPRING	2				0.001	0.0022
008	37307-71360	PIN JOINT	2				0	0
009	34150-37640	PIN SET	2				0.06	0.132
010	37307-71310	LINK LOWER	2				9	19.8
011	34150-37640	PIN SET	2				0.06	0.132
012	37307-71560	ASSY ROD LIFT	1				4	8.8
013	37307-71520	ROD LIFT LOWER	1				1.14	2.508
014	38247-71570	JOINT GEAR CASE	1				0	0
015	38247-71550	PIN LIFT ROD	1				0.11	0.242
016	05411-00532	PIN SPRING	1				0.003	0.0066
017	38247-71590	ASSY JOINT GEAR CASE	1				0	0
018	34264-71710	CASE LIFT ROD GEAR	1				0	0
019	32244-71610	HANDLE LIFT ROD	1				0.229	0.5038
020	32244-71640	GEAR LIFT ROD 1	1				0.4	0.88
021	32244-71650	GEAR LIFT ROD 2	1				0.126	0.2772
022	32244-71670	COLLAR	1				0.027	0.0594
023	05411-00622	PIN SPRING	2				0.003	0.0066
024	31220-71720	SHIM	3				0.001	0.0022
025	32294-71770	BEARING THRUST BALL	1				0.073	0.1606
026	06311-75045	PLUG EXPANSION	1				0.026	0.0572
027	32244-71730	STOPPER HANDLE	1				0.027	0.0594
028	06613-10675	NIPPLE GREASE	1				0.003	0.0066
029	34264-71704	PIPE	1				0.49	1.078
030	01202-50612	BOLT	1				0.005	0.011
031	06613-10675	NIPPLE GREASE	1				0.003	0.0066
032	05411-00420	PIN SPRING	1				0.001	0.0022
033	37307-71540	ROD LIFT LH	1				1.98	4.356
034	34354-71580	PIN LIFT ROD	2				0.09	0.198
035	05515-51600	PIN SNAP	2				0.007	0.0154
036	37307-71810	CHAIN CHECK 1	2				0.8	1.76
037	32353-71890	PIN	2				0.041	0.0902
038	05511-50425	PIN SPLIT	2				0.003	0.0066
039	37307-71820	CHAIN CHECK 2	2				0.775	1.705
040	37307-71830	WASHER CHECK CHAIN	2				0.29	0.638
041	02174-50180	NUT	2				0.029	0.0638
042	04512-50180	WASHER SPRING	2				0	0
043	36200-91190	BUCKLE TURN	2				0.63	1.386
044	02154-50160	NUT	2				0.025	0.055
045	04013-50120	WASHER PLAIN	2				0	0
046	37267-71800	ASSY CHECK CHAIN	2				2.1	4.62

# HAZARD LAMP (OPTION)

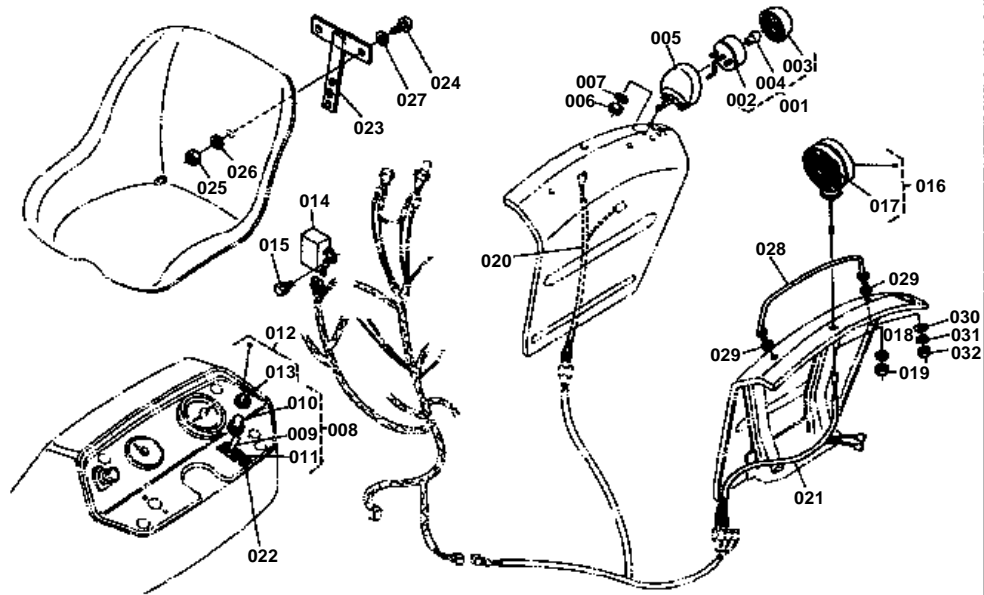

1031(F) ~  
1051X(DT)~

USA



**HAZARD LAMP (OPTION)**

↔ Interchangeable; ≠ not interchangeable; ← new for old; → old for new

REF.No	Part No.	Description	Q'ty	S.No.	I/C	REMARKS	Weight (kgf)	Weight (lb)
001	34350-34100	ASSY LAMP TAIL	2				0.13	0.286
002	99999-99999	BLANK	0			ORDER BY REF.No.001	0	0
003	34350-34120	LENS TAIL LAMP	2				0.05	0.11
004	34350-34140	BULB TAIL LAMP	2				0.008	0.0176
005	34350-34190	HOLDER TAIL LAMP	2				0.107	0.2354
006	02014-50060	NUT	4				0.003	0.0066
007	04512-50060	WASHER SPRING	4				0	0
008	54721-41300	ASSY SWITCH	1				0.03	0.066
009	99999-99999	BLANK	0			ORDER BY REF.No.008	0	0
010	54721-22330	CAP	1				0.002	0.0044
011	54721-22340	LABEL	1				0.001	0.0022
012	66711-55290	ASSY LAMP OIL	1				0.016	0.0352
013	34150-34590	BULB	1				0.001	0.0022
014	35170-33700	UNIT FLASHER	1				0.06	0.132
015	01202-50616	BOLT	1				0.006	0.0132
016	35450-75010	ASSY LAMP HAZARD FLA	2				0.3	0.66
017	35450-75022	BULB HAZARD FLASHER	2				0.008	0.0176
018	04512-50100	WASHER SPRING	2				0	0
019	02114-50100	NUT	2				0.005	0.011
020	35340-34360	WIRE HARNESS 6	1				0.04	0.088
021	35340-34370	WIRE HARNESS 7	1				0.05	0.11
022	35320-31840	LABEL HAZARD MARK	1				0.005	0.011
023	35320-18480	BRACKET PLATE	1				0.22	0.484
024	03014-50616	SCREW	2				0.003	0.0066
025	02014-50060	NUT	2				0.003	0.0066
026	04512-50060	WASHER SPRING	2				0	0
027	04012-50060	WASHER PLAIN	2				0.001	0.0022
028	35340-29170	BALUSTRAD	2				0.675	1.485
029	32260-29180	CUSHION	4				0.005	0.011
030	04013-50140	WASHER PLAIN	4				0	0
031	04512-50140	WASHER SPRING	4				0	0
032	02174-50140	NUT	4				0.014	0.0308

# CONTROL VALVE

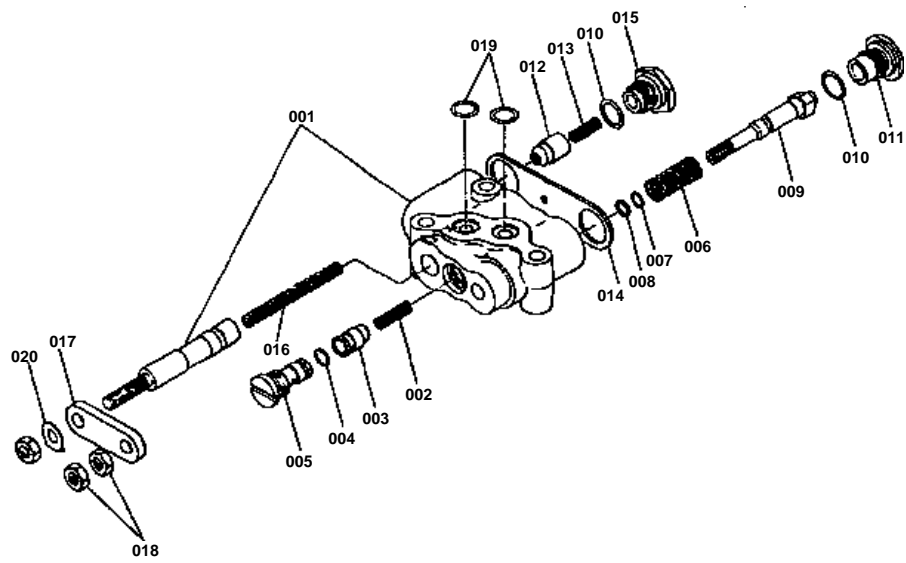



# CONTROL VALVE

↔ Interchangeable; ≠ not interchangeable; ← new for old; → old for new

REF.No	Part No.	Description	Q'ty	S.No.	I/C	REMARKS	Weight (kgf)	Weight (lb)
001	99999-99999	BLANK	0			ORDER BY REF.No.021	0	0
002	37150-36580	SPRING	1				0.005	0.011
003	37150-36590	VALVE CHECK	1				0.015	0.033
004	04811-00090	O RING	1				0.001	0.0022
005	37150-36440	SEAT	1				0.035	0.077
006	37150-36450	SPRING	1				0.005	0.011
007	04811-00070	O RING	1				0.001	0.0022
008	37150-36630	RING BACK UP	1				0.001	0.0022
009	37150-36460	POPPET	1				0.005	0.011
010	04811-00150	O RING	2				0.001	0.0022
011	37150-36470	PLUG SEAT	1				0.04	0.088
012	37150-36480	VALVE UNLOADER	1				0.02	0.044
013	37150-36490	SPRING	1				0.005	0.011
014	37150-36510	PLATE	1				0.035	0.077
015	37150-36520	PLUG	1				0.043	0.0946
016	37150-36530	SPRING RETURN	1				0.01	0.022
017	37150-36540	PLATE	1				0.145	0.319
018	37150-36550	NUT	3				0.005	0.011
019	04811-00120	O RING	2				0.001	0.0022
020	37150-36560	PLATE LOCK	1				0.01	0.022
021	37150-36400	VALVE CONTROL	1				1.675	3.685

# DRAFT CONTROL VALVE

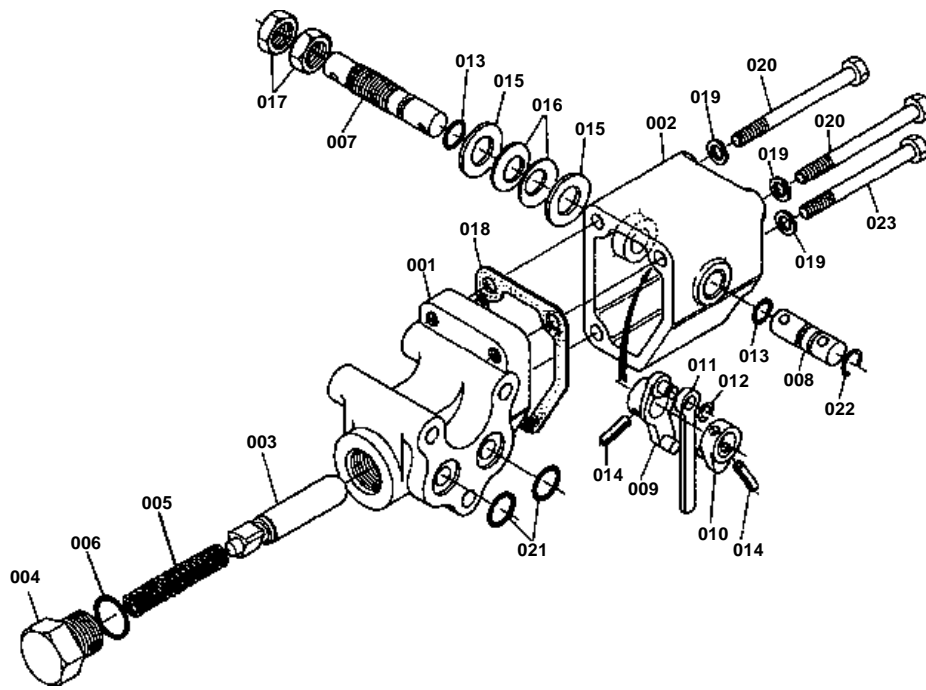



# DRAFT CONTROL VALVE

↔ Interchangeable; ≠ not interchangeable; ← new for old; → old for new

REF.No	Part No.	Description	Q'ty	S.No.	I/C	REMARKS	Weight (kgf)	Weight (lb)
001	99999-99999	BLANK	0			ORDER BY REF.No.024	0	0
002	37300-41120	CAP	1				1.05	2.31
003	99999-99999	BLANK	0			ORDER BY REF.No.024	0	0
004	37300-41140	PLUG	1				0.098	0.2156
005	37300-41150	SPRING	1				0.01	0.022
006	04811-00180	O RING	1				0.001	0.0022
007	37300-41160	SHAFT	1				0.065	0.143
008	37300-41170	SHAFT	1				0.03	0.066
009	37300-41180	ARM	1				0.03	0.066
010	32240-36630	ARM	1				0.015	0.033
011	37300-41270	LINK	1				0.012	0.0264
012	04613-50050	RING SNAP	1				0.001	0.0022
013	04811-00090	O RING	2				0.001	0.0022
014	05411-00518	PIN SPRING	2				0.002	0.0044
015	04011-50140	WASHER PLAIN	2				0.007	0.0154
016	37300-41280	WASHER SPRING	2				0.005	0.011
017	02172-50140	NUT	2				0.01	0.022
018	37300-41290	GASKET	1				0.001	0.0022
019	04512-50080	WASHER SPRING	3				0	0
020	01150-50875	BOLT	2				0	0
021	04810-00160	O RING	2				0.001	0.0022
022	37300-41360	RING SNAP	1				0.001	0.0022
023	01150-50870	BOLT	1				0	0
024	37300-41100	ASSY VALVE DRAFT CON	1				3.2	7.04

# OIL PRESSURE PUMP

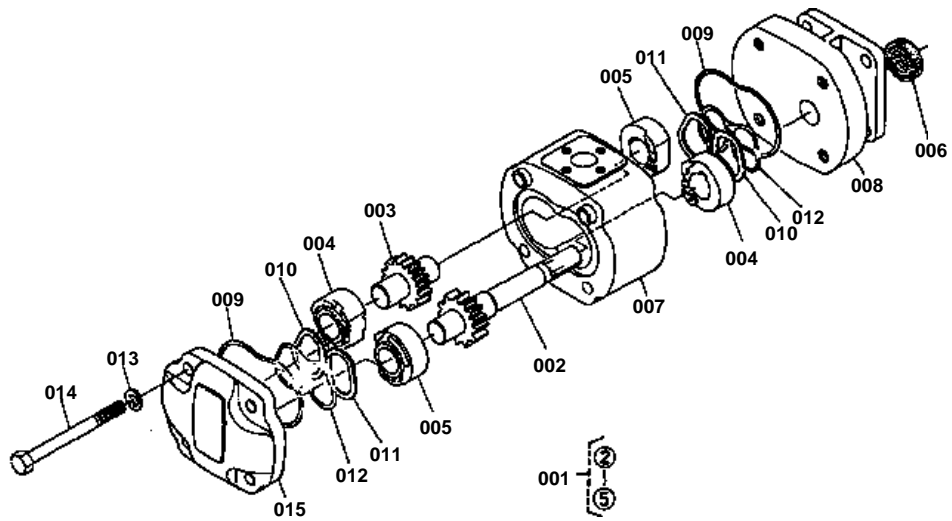



# OIL PRESSURE PUMP

↔ Interchangeable; ≠ not interchangeable; ← new for old; → old for new

REF.No	Part No.	Description	Q'ty	S.No.	I/C	REMARKS	Weight (kgf)	Weight (lb)
001	35320-36200	ASSY BUSH GEAR	1				0.71	1.562
002	99999-99999	BLANK	0			ORDER BY REF.No.001	0	0
003	99999-99999	BLANK	0			ORDER BY REF.No.001	0	0
004	99999-99999	BLANK	0			ORDER BY REF.No.001	0	0
005	99999-99999	BLANK	0			ORDER BY REF.No.001	0	0
006	35320-36230	SEAL OIL	1				0.005	0.011
007	99999-99999	BLANK	0			ORDER BY REF.No.016	0	0
008	99999-99999	BLANK	0			ORDER BY REF.No.016	0	0
009	35320-36260	SEAL BODY	2				0.005	0.011
010	35320-36220	RING GASKET L	2				0.001	0.0022
011	35320-36250	RING GASKET R	2				0.002	0.0044
012	35320-36240	SEAL BUSH	2				0.005	0.011
013	04512-50100	WASHER SPRING	4				0	0
014	35320-36310	BOLT	4				0.055	0.121
015	99999-99999	BLANK	0			ORDER BY REF.No.016	0	0
016	35320-36100	PUMP OIL PRESSURE	1				0	0

INTEGRAL TYPE POWER STEERING

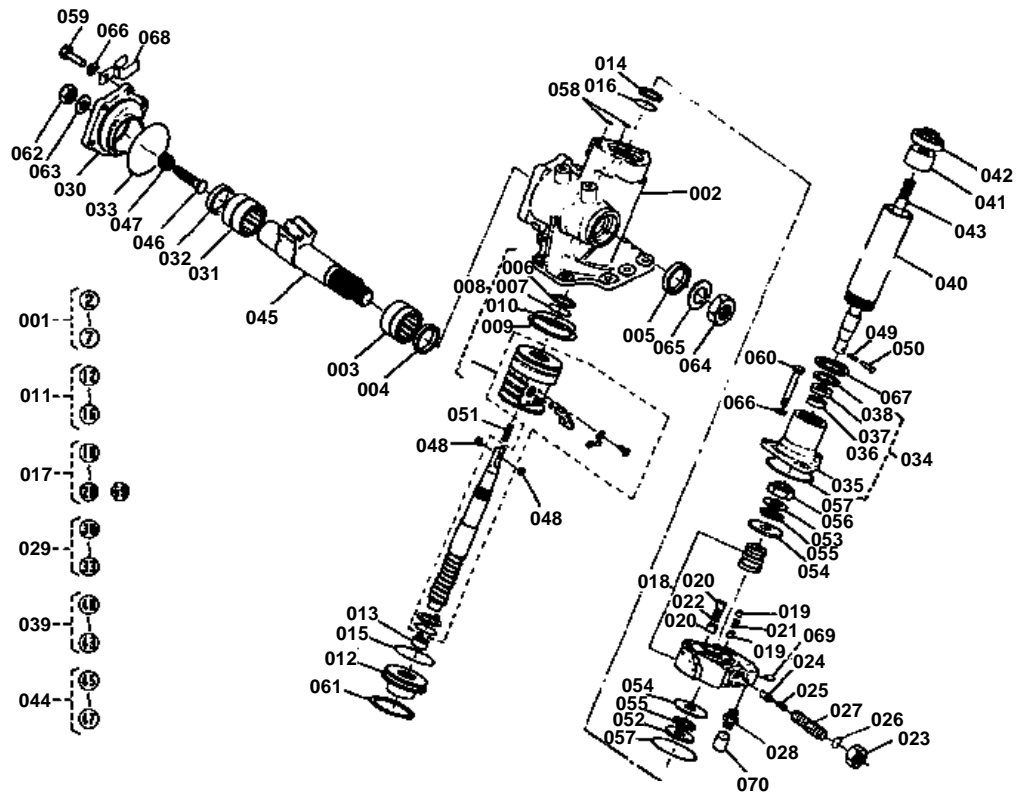





INTEGRAL TYPE POWER STEERING

↔ Interchangeable; ≠ not interchangeable; ← new for old; → old for new

REF.No	Part No.	Description	Q'ty	S.No.	I/C	REMARKS	Weight (kgf)	Weight (lb)
001	35350-16160	ASSY BOX GEAR	1				7	15.4
002	99999-99999	BLANK	0			ORDER BY REF.No.001	0	0
003	38430-66120	BEARING NEEDLE	1				0.195	0.429
004	38430-66130	U PACKING	1				0.005	0.011
005	38430-66140	SEAL OIL	1				0.02	0.044
006	38430-66150	RING	1				0.002	0.0044
007	04811-10340	O RING	1				0.001	0.0022
008	35350-16200	ASSY BALL NUT	1				3	6.6
009	38430-66220	RING	1				0.005	0.011
010	04811-10600	O RING	1				0.001	0.0022
011	35350-16270	ASSY COVER FRONT	1				0.34	0.748
012	38430-66250	COVER FRONT	1				0.34	0.748
013	38430-66260	BEARING NEEDLE	1				0.015	0.033
014	38430-66150	RING	1				0.002	0.0044
015	04811-50650	O RING	1				0.002	0.0044
016	04811-10340	O RING	1				0.001	0.0022
017	38430-66300	ASSY VALVE	1				0	0
017	35350-66300	ASSY VALVE	1	>=10001			2	4.4
018	99999-99999	BLANK	0			ORDER BY REF.No.017	0	0
019	38430-66320	PISTON 1	4				0.01	0.022
020	38430-66330	PISTON 2	4				0.005	0.011
021	38430-66340	SPRING	2				0.01	0.022
022	38430-66350	SPRING	2				0.003	0.0066
023	38430-66360	NUT	1				0.03	0.066
024	38430-66370	POPPET	1				0.01	0.022
025	38430-66380	SPRING	1				0.015	0.033
026	04811-00180	O RING	1				0.001	0.0022
027	38430-66390	SCREW ADJUSTING	1				0.04	0.088
028	38430-45230	NIPPLE	2				0.04	0.088
029	35350-16600	ASSY COVER SIDE	1				1.365	3.003
030	38430-66470	COVER SIDE	1				1.22	2.684
031	38430-66480	BEARING NEEDLE	1				0.12	0.264
032	38430-66130	U PACKING	1				0.005	0.011
033	04811-50800	O RING	1				0.003	0.0066
034	35350-16400	ASSY COVER REAR	1				1.4	3.08
035	38430-66420	COVER REAR	1				0.81	1.782
036	38430-66440	BEARING NEEDLE	1				0.015	0.033
037	38430-66450	SEAL OIL	1				0.01	0.022
038	04611-00320	CIR-CLIP EXTERNAL	1				0.002	0.0044
039	35350-16500	ASSY COLUMN	1				0.95	2.09
040	38430-66510	COLUMN	1				0.89	1.958
041	38240-16520	BUSH	1				0.04	0.088
042	38240-16390	SEAL OIL	1				0.03	0.066
043	38430-66520	ASSY SHAFT STEERING	1				0.57	1.254
044	35350-16700	ASSY SHAFT SECTOR	1				2.09	4.598
045	38430-66710	SHAFT SECTOR	1				2	4.4
046	38430-66750	SCREW ADJUSTING	1				0.07	0.154
047	38430-66760	ADJUSTOR	1				0.015	0.033
048	38240-16530	O RING	2				0.001	0.0022
049	05411-00522	PIN SPRING	1				0.002	0.0044
049	05411-00518	PIN SPRING	1	>=10001			0.002	0.0044
050	35350-66820	RIVET	1				0.003	0.0066
051	38240-16490	SPRING	1				0.005	0.011
052	38430-66610	RING DRIVE	1				0.05	0.11
053	38430-66620	RING DRIVE	1				0.02	0.044
054	38430-66630	RING DRIVE	2				0.06	0.132
055	38430-66640	BEARING NEEDLE	2				0.01	0.022
056	38430-66650	NUT	1				0.065	0.143
057	04811-10700	O RING	2				0.001	0.0022

**INTEGRAL TYPE POWER STEERING**

↔ Interchangeable; ≠ not interchangeable; ← new for old; → old for new

REF.No	Part No.	Description	Q'ty	S.No.	I/C	REMARKS	Weight (kgf)	Weight (lb)
058	04811-00800	O RING	2				0.009	0.0198
059	01173-51028	BOLT	6				0.022	0.0484
060	38430-66660	BOLT	3				0.05	0.11
061	04611-00720	CIR-CLIP EXTERNAL	1				0.018	0.0396
062	38430-66770	NUT	1				0.02	0.044
063	38430-66780	GASKET	1				0.001	0.0022
064	38430-66720	NUT	1				0.145	0.319
065	38430-66730	WASHER SPRING	1				0.05	0.11
066	04512-50100	WASHER SPRING	9				0	0
067	38430-66740	NUT	1				0.02	0.044
068	35350-16780	CLIP	1				0.018	0.0396
069	38430-66790	PLUG	2				0.003	0.0066
070	38430-66800	PLUG LAPPING	2				0.01	0.022

**IMAGE NOT AVAILABLE**

**ACCESSORY AND SERVICE PARTS**

↔ Interchangeable; ≠ not interchangeable; ← new for old; → old for new

REF.No	Part No.	Description	Q'ty	S.No.	I/C	REMARKS	Weight (kgf)	Weight (lb)
001	35300-19100	ASSY TOOLS	1			NOT SHOWN IN FIG.	1.48	3.256
002	15221-86612	WRENCH FILTER	1			NOT SHOWN IN FIG.	0.12	0.264
003	15221-88650	DETERGENT AIR CLEANER	1			NOT SHOWN IN FIG.	0	0

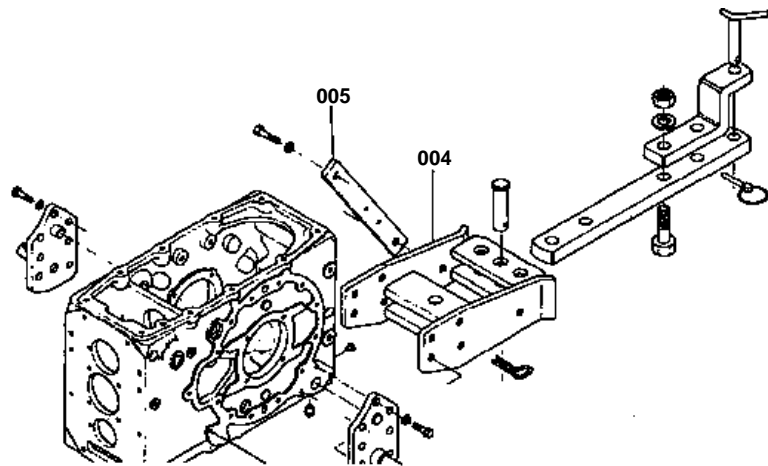



## TRANSMISSION CASE (SERVICE PARTS)

↔ Interchangeable; ≠ not interchangeable; ← new for old; → old for new

REF.No	Part No.	Description	Q'ty	S.No.	I/C	REMARKS	Weight (kgf)	Weight (lb)
004	37300-29710	FRAME DRAWBAR	1	≤10101			9.6	21.12
005	37300-29720	LINK SUPPORT	2	≤10101			1.2	2.64

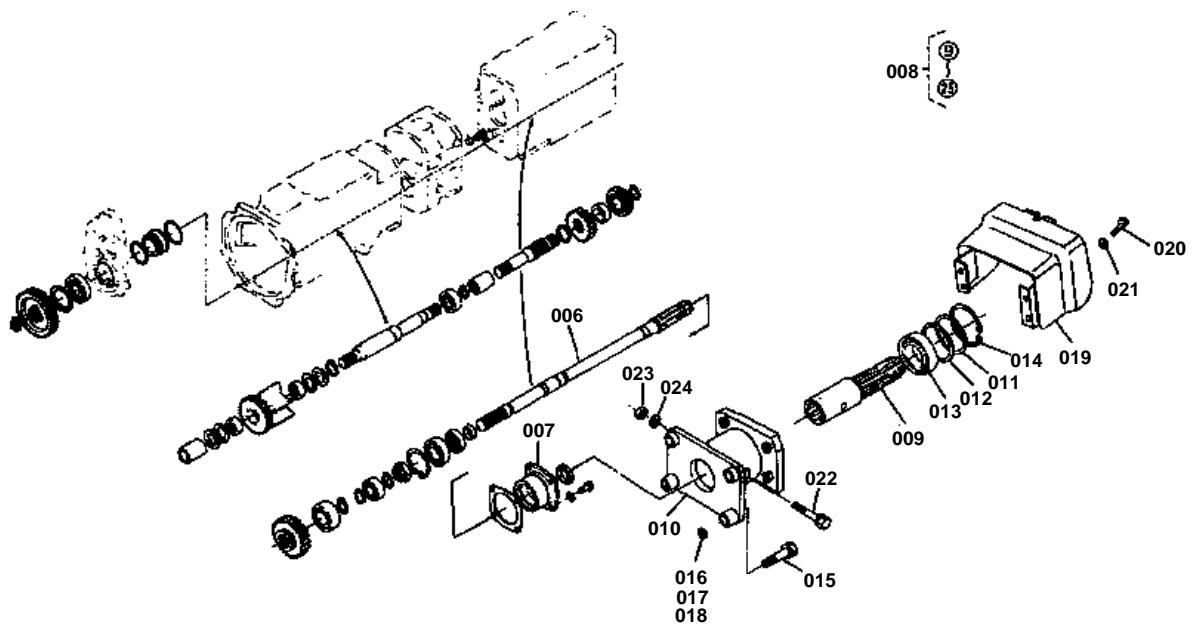

**TRANSMISSION 3 (SERVICE PARTS)**

↔ Interchangeable; ≠ not interchangeable; ← new for old; → old for new

REF.No	Part No.	Description	Q'ty	S.No.	I/C	REMARKS	Weight (kgf)	Weight (lb)
006	35340-25313	SHAFT (PTO)	1	≤10101			3.5	7.7
007	35340-25410	CASE BEARING	1	≤10101			1.045	2.299
008	35320-99000	ASSY EXTENSION PTO	1	≤10101			8.175	17.985
009	35320-99010	SHAFT EXTENSION PTO	1	≤10101			1.46	3.212
010	35320-99040	BRACKET PTO	1	≤10101			3.4	7.48
011	35320-99050	WASHER 1	1	≤10101			0.04	0.088
012	35320-99060	WASHER 2	1	≤10101			0.01	0.022
013	08141-06009	BEARING	1	≤10101			0.232	0.5104
014	04611-00750	CIR-CLIP INTERNAL	1	≤10101			0.019	0.0418
015	01133-51250	BOLT	4	≤10101			0.055	0.121
016	35320-99070	SHIM 0.1	3	≤10101			0.001	0.0022
017	35320-99080	SHIM 0.2	3	≤10101			0.001	0.0022
018	35320-99090	SHIM 0.5	1	≤10101			0.002	0.0044
019	35244-25330	PROTECTOR SHAFT PTO	1	≤10101			2.28	5.016
020	01133-51230	BOLT	4	≤10101			0.04	0.088
021	04013-50120	WASHER PLAIN	4	≤10101			0	0
022	01123-50860	BOLT	1	≤10101			0.026	0.0572
023	41011-51510	NUT	1	≤10101			0.006	0.0132
024	04013-50080	WASHER PLAIN	1	≤10101			0	0
025	35320-99100	INSTRUCTION MANUAL	1	≤10101		NOT SHOWN IN FIG.	0.01	0.022



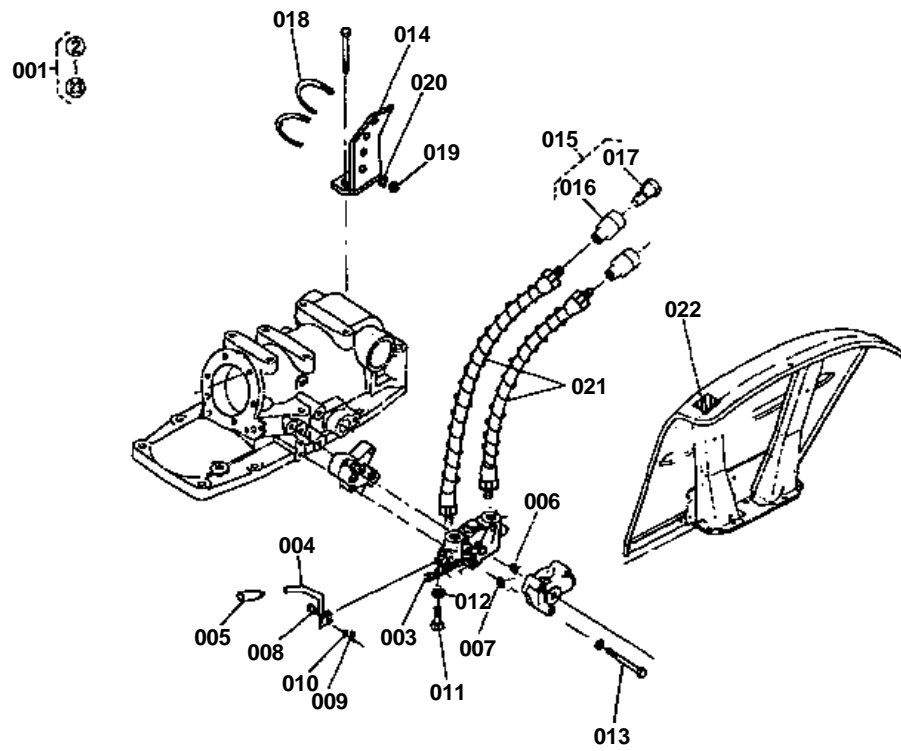



## ACCESSARY AND SERVICE PARTS (DOUBLE ACTING X 1)

↔ Interchangeable; ≠ not interchangeable; ← new for old; → old for new

REF.No	Part No.	Description	Q'ty	S.No.	I/C	REMARKS	Weight (kgf)	Weight (lb)
001	35320-99420	ASSY COUPLER OIL PRE	1				5.4	11.88
002	35340-99410	ASSY VALVE CONTROL	1			NOT SHOWN IN FIG.	2.7	5.94
003	35340-99420	VALVE CONTROL	1				2.5	5.5
004	35340-99430	LEVER CONTROL	1				0.2	0.44
005	06914-00100	GRIP LEVER	1				0.02	0.044
006	04811-00120	O RING	3				0.001	0.0022
007	04811-00160	O RING	1				0.001	0.0022
008	68021-32790	PIN	2				0.004	0.0088
009	05511-51208	PIN SPRING	2				0.001	0.0022
010	04012-50050	WASHER SPRING	2				0.001	0.0022
011	01152-50828	BOLT	1				0.014	0.0308
012	02112-50080	NUT	1				0.003	0.0066
013	35340-99440	BOLT	3				0.085	0.187
014	35340-99450	BRACKET JOINT RH	1				0.26	0.572
015	35700-82400	ASSY COUPLER	1				0.45	0.99
016	35700-82410	ASSY COUPLER FEMALE	2				0	0
017	35700-82420	ASSY COUPLER MALE	2				0.09	0.198
018	35340-99470	BOLT U	2				0.03	0.066
019	02014-50060	NUT	4				0.003	0.0066
020	04512-50060	WASHER SPRING	4				0	0
021	35340-99490	HOSE OIL 2	2				0.395	0.869
022	35340-99500	LABEL	1				0.003	0.0066
023	35340-99510	MANUAL	1			NOT SHOWN IN FIG.	0.015	0.033

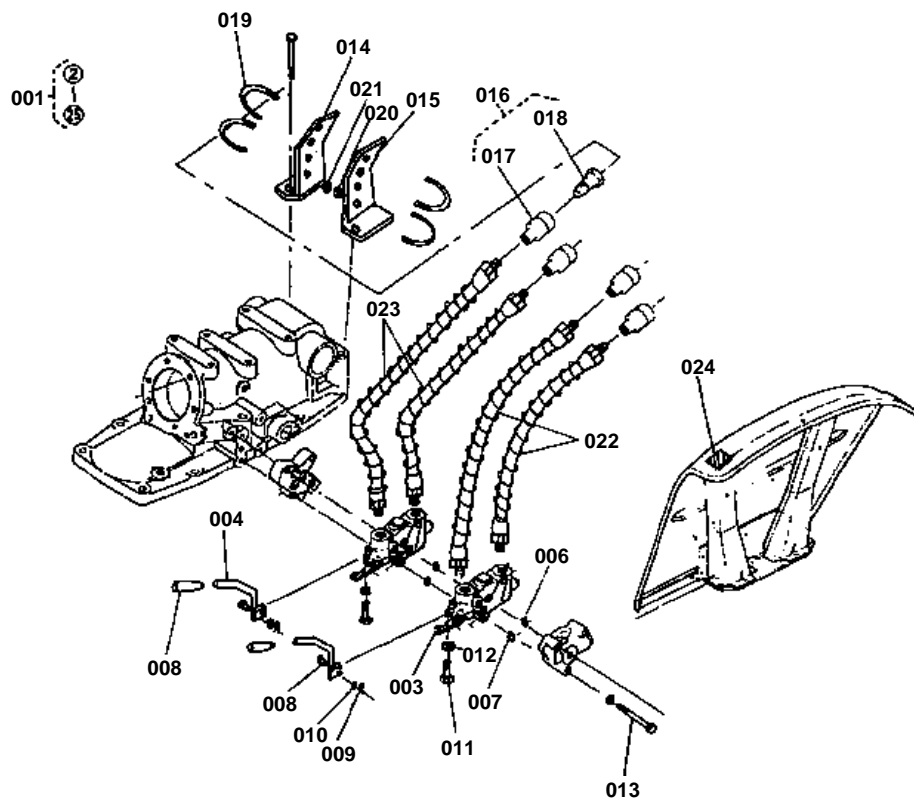



## ACCESSARY AND SERVICE PARTS (DOUBLE ACTING X 2)

↔ Interchangeable; ≠ not interchangeable; ← new for old; → old for new

REF.No	Part No.	Description	Q'ty	S.No.	I/C	REMARKS	Weight (kgf)	Weight (lb)
001	35320-99400	ASSY COUPLER OIL PRE	1				9.1	20.02
002	35340-99410	ASSY VALVE CONTROL	2			NOT SHOWN IN FIG.	2.7	5.94
003	35340-99420	VALVE CONTROL	2				2.5	5.5
004	35340-99430	LEVER CONTROL	2				0.2	0.44
005	06914-00100	GRIP LEVER	2				0.02	0.044
006	04811-00120	O RING	6				0.001	0.0022
007	04811-00160	O RING	2				0.001	0.0022
008	68021-32790	PIN	4				0.004	0.0088
009	05511-51208	PIN SPRING	4				0.001	0.0022
010	04012-50050	WASHER SPRING	4				0.001	0.0022
011	01152-50828	BOLT	2				0.014	0.0308
012	02112-50080	NUT	2				0.003	0.0066
013	35320-99410	BOLT	3				0.105	0.231
014	35340-99450	BRACKET JOINT RH	1				0.26	0.572
015	35340-99460	BRACKET JOINT LH	1				0.3	0.66
016	35700-82400	ASSY COUPLER	2				0.45	0.99
017	35700-82410	ASSY COUPLER FEMALE	4				0	0
018	35700-82420	ASSY COUPLER MALE	4				0.09	0.198
019	35340-99470	BOLT U	4				0.03	0.066
020	02014-50060	NUT	8				0.003	0.0066
021	04512-50060	WASHER SPRING	8				0	0
022	35340-99480	HOSE OIL 1	2				0.34	0.748
023	35340-99490	HOSE OIL 2	2				0.395	0.869
024	35340-99500	LABEL	1				0.003	0.0066
025	35340-99510	MANUAL	1			NOT SHOWN IN FIG.	0.015	0.033